

D02G

CRIMPING OR CURLING FIBRES, FILAMENTS, THREADS, OR YARNS; YARNS OR THREADS

Definition statement

This subclass/group covers:

The post treatment of fibres and filaments (usually synthetic) to give them a structure more like natural fibres i.e. crimped or curled to make them easier to work with during further processing.

Relationship between large subject matter areas

[D02G 3/00](#) covers the making of yarns or threads, e.g. fancy yarns; processes or apparatus for the production. [D02G](#) concerns treatments before this stage.

References relevant to classification in this subclass

This subclass/group does not cover:

Unwinding, paying-out, forwarding, winding or coiling filamentary material not intimately associated with spinning or twisting	B65H
Cores, formers, supports or holders for coiled or wound material, e.g. bobbins	B65H
Mechanical methods or apparatus in the manufacture of artificial filaments, threads, fibres, bristles, or ribbons	D01D
Chemical features in the manufacture of artificial filaments, threads, fibres, bristles, or ribbons; apparatus specially adapted for the manufacture of carbon filaments	D01F
Twisting oakum	D01G 35/00
Spinning or twisting	D01H
Yarns or threads, e.g. fancy yarns; Processes or apparatus for the production thereof	D02G 3/00
Making chenille	D03D , D04D 3/00

General aspects of chemical treatment	D06M
Testing yarns, rovings, slivers, fibres, or fibre webs	G01

Special rules of classification within this subclass

The "common rule" applies in each of the subgroups

Glossary of terms

In this subclass/group, the following terms (or expressions) are used with the meaning indicated:

Fibre	a relatively-short, elongated member of natural or artificial material.
Filament	an endless or quasi-endless, elongated member of natural or artificial material.
Yarn	a unitary assembly of fibres, usually produced by spinning.
Thread	an assembly of yarns or filaments, usually produced by twisting.
False twisting	synthetic filaments are twisted, heat set while twisted and then untwisted to form a crimp
Texturing or texturizing	curling and crimping
Stuffer box	a confined space where yarns or filaments are compressed and deformed

D02G 1/00

Producing crimped or curled fibres, filaments, yarns, or threads, giving them latent characteristics (yarns per se D02G3/00; during formation of artificial filaments, threads, or

the like D01D5/22; general aspects of chemical treatment D06M)

D02G 3/00

Yarns or threads, e.g. fancy yarns; Processes or apparatus for the production thereof, not otherwise provided for (for producing crimped or curled yarns D02G1/00)

Definition statement

This subclass/group covers:

Yarns or threads characterised by the material or by the materials from which they are made. These aspects are covered by [D02G 3/02](#).

Yarns or threads characterised by constructional features. These aspects are covered by [D02G 3/22](#).

Yarns or threads characterised by the purpose for which they are designed. These aspects are covered by [D02G 3/44](#).

References relevant to classification in this group

This subclass/group does not cover:

Shoe laces	A43C 1/00
Dental floss	A61C 15/04
Ropes and strands for ropes	D07B
Warp knitted yarns	D04B 21/202
Braided cords, lines or tows	D04C 1/12

Informative references

Attention is drawn to the following places, which may be of interest for search:

Selection of special materials for outerwear	A41D 31/00
Woven materials characterised by the material or construction of the yarn	D03D 15/00
Weft knitting processes characterised primarily by the use of particular	D04B 1/14

thread materials	
Warp knitting processes characterised by the incorporation by knitting, in one or more thread, fleece, or fabric layers, of reinforcing, binding, or decorative threads	D04B 21/14
Wearing apparel	A41B - A41G

D02G 3/02

Yarns or threads characterised by the material or by the materials from which they are made

Special rules of classification within this group

The classification is desirably complemented by a classification in the indexing scheme [D10B 2101/00](#) to [D10B 2331/301](#) for identifying the thread composition.

D02G 3/045

[N: all components being made from artificial or synthetic material]

Definition statement

This subclass/group covers:

Blended or other yarns or threads containing components including aramid fibres and similar high performance fibres.

Synonyms and Keywords

In patent document the following expressions/word "Aromatic polyamide" is often used with the meaning "aramid".

In patent document the following expressions/word "Para aramid" is often used with the meaning "terephthalamide (PPTA)".

In patent document the following expressions/word "Meta aramid" is often used with the meaning "poly-metaphenylene isophthalamide (MPIA)".

In patent document the following expressions/word "Ultra high molecular weight polyethylene (UHMWPE)" is often used with the meaning "poly(p-phenylene-2,6-benzobisoxazole)".

D02G 3/08

Paper yarns or threads

Informative references

Attention is drawn to the following places, which may be of interest for search:

Woven fabrics characterised by using paper threads	D03D 15/0072
--	------------------------------

D02G 3/12

Threads containing metallic filaments or strips

Informative references

Attention is drawn to the following places, which may be of interest for search:

Woven fabrics characterised by the warp or weft elements being of stiff material, e.g. wire	D03D 15/02
Gloves made of wire-mesh	A41D 19/01511
Resistance heating devices in seats specially adapted for vehicles	B60N 2/5685

D02G 3/16

Yarns or threads made from mineral substances

Informative references

Attention is drawn to the following places, which may be of interest for search:

Artificial filaments or the like of other substances, manufacture thereof, apparatus specially adapted for the manufacture of carbon filaments	D01F 9/00
Woven fabrics characterised by using threads comprising a mineral	D03D 15/0016

Special rules of classification within this group

The classification is desirably complemented by a classification in the Indexing Codes [D10B 2101/00](#) to [D10B 2101/16](#) for identifying the thread composition.

D02G 3/18

from glass or the like

Informative references

Attention is drawn to the following places, which may be of interest for search:

Woven fabrics using glass fibres	D03D 15/0011
Glass fibre or filament	C03C 13/00
Fibreglass strands extruded from spinnerets	B65H 2701/3122

D02G 3/28

Doubled, plied, or cabled threads [N: (D02G3/32, D02G3/36 take precedence; effect yarns D02G3/34; details of spindles, e.g. bearings D01H7/86)]

Definition statement

This subclass/group covers:

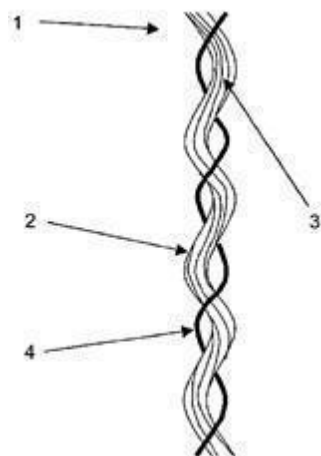

US-A-2004/0065072

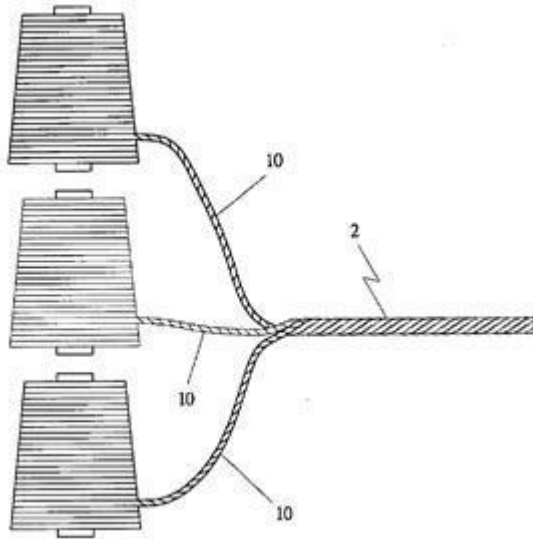

US-A-2005/0009430

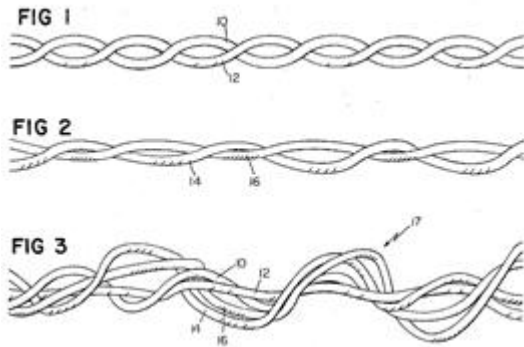

US-A-3 690 056

Glossary of terms

In this subclass/group, the following terms (or expressions) are used with the meaning indicated:

<p>Doubled yarns</p>	<p>yarns consisting of two or more strands treated as one in the weaving process. The strands are not twisted together. The doubled yarn must not be confused with ply yarns, which are stronger because they are twisted.</p>
<p>Plied or folded yarns</p>	<p>yarns comprising two or more strands or yarns twisted together. They are termed two-ply, three-ply, and so on, according to the number used in their construction. Ply yarns are preferred where durability is all-important.</p>

Cabled or cord yarns	yarns comprising two or more plied yarns twisted together. In general they are constructed by twisting the plied yarns around each other successively in the opposite direction of the preceding twist, i.e. S/Z/S or Z/S/Z. As a result, the opposite twist directions cause the plies to grip each other and maintain adherence. These yarns are hard, rough and strong.
----------------------	--

D02G 3/281

[N: using one drawing frame for two slivers and twisting of the slivers to a single yarn, i.e. spin-twisting (guides having associated actuators with mutual action D01H13/1658)]

Definition statement

This subclass/group covers:

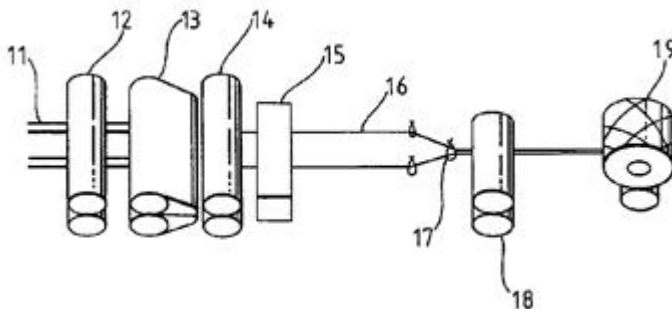

EP-A-0 038 143

D02G 3/283

[N: using hollow spindles through which one yarn is running]

Definition statement

This subclass/group covers:

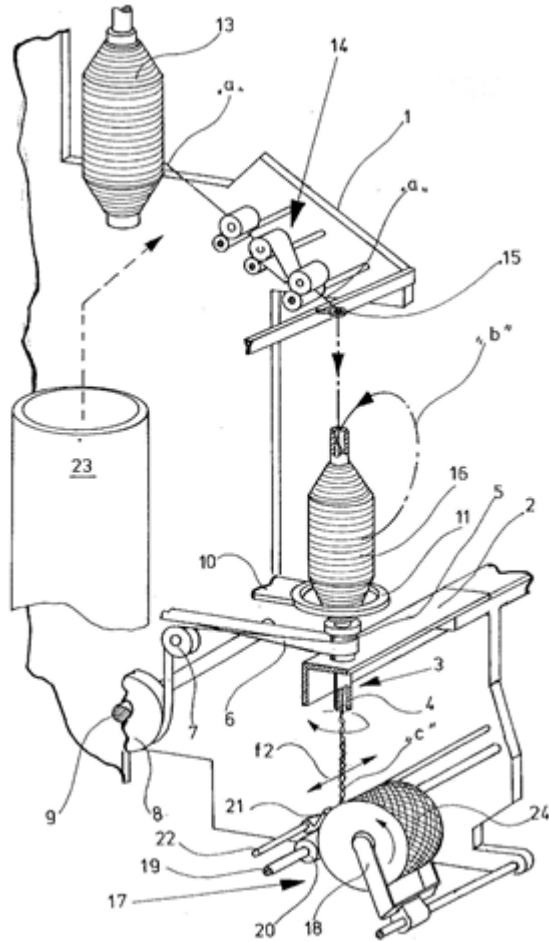

EP-A-0 593 919

Informative references

Attention is drawn to the following places, which may be of interest for search:

Multiple twist arrangements	D01H 7/86
-----------------------------	---------------------------

D02G 3/285

[N: one yarn running over the feeding spool of another yarn]

Definition statement

This subclass/group covers:

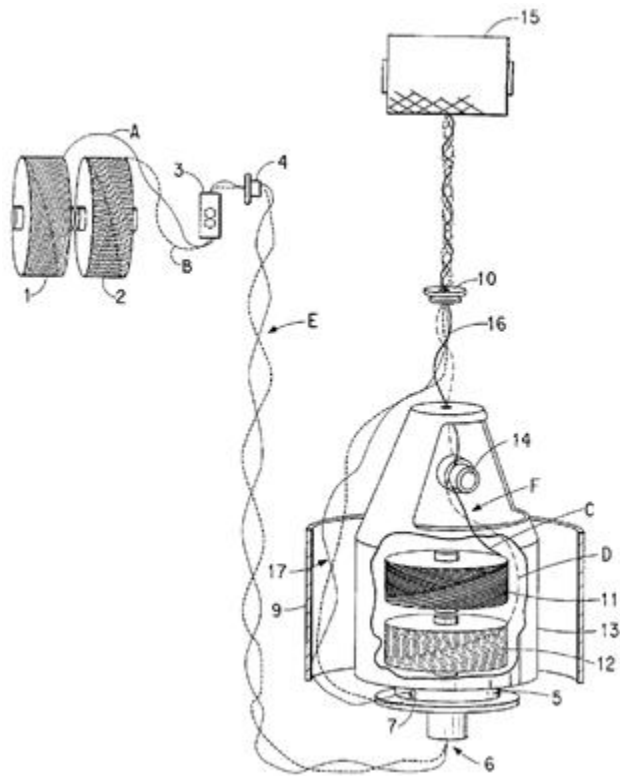

US-A-6 098 392

Informative references

Attention is drawn to the following places, which may be of interest for search:

Multiple twist arrangements	D01H 7/86
Spinning or twisting machines for imparting multiple twist, e.g. two-for-one twisting	D01H 1/10

D02G 3/286

[N: with alternatively "S" and "Z" direction of twist, e.g. Self-twist process]

Definition statement

This subclass/group covers:

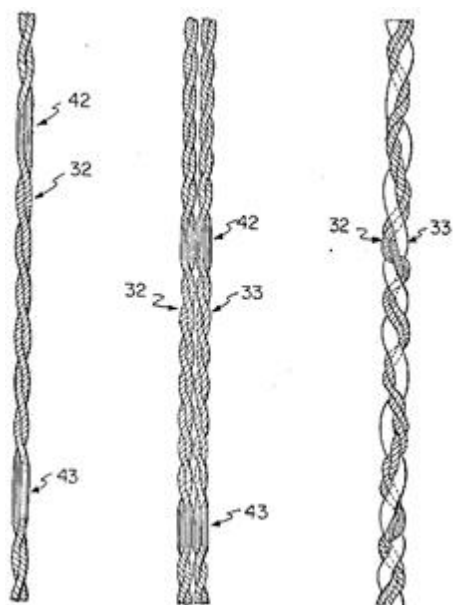

US-A-4 246 750

Glossary of terms

In this subclass/group, the following terms (or expressions) are used with the meaning indicated:

<p>Self-twist yarn</p>	<p>yarn that comprises two or more strands that have areas of twist in what is known as the Z-direction and areas of twist in what is known as the S-direction. The twisted areas in the strands are each separated by non-twisted areas. Torque is trapped in the twisted strand and is otherwise known as residual twist. When two or more twisted strands are brought together, the torque or residual twist causes the strands to twist around each other naturally, without interference, to form a self twisted yarn.</p>
------------------------	---

D02G 3/288

[N: with same direction of twist, but with an amount of twist varying along the thread]

Definition statement

This subclass/group covers:

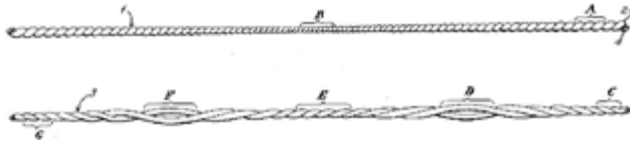

US-A-2 961 010

D02G 3/30

Crêped or other highly-twisted yarns or threads

Glossary of terms

In this subclass/group, the following terms (or expressions) are used with the meaning indicated:

Crêped yarns or hard twist	yarns with a number of twist per unit of length higher than ordinary yarn.
----------------------------	--

D02G 3/32

Elastic yarns or threads; [N: Production of plied or cored yarns, one of which is elastic]

Informative references

Attention is drawn to the following places, which may be of interest for search:

Woven fabrics using stretchable or elastic threads	D03D 15/08
Abrics or articles defined by weft knitting using elastic threads	D04B 1/18
Fabrics or articles defined by warp knitting incorporating elastic threads	D04B 21/18

D02G 3/322

[N: using hollow spindles (details of spindles, e.g. bearings D01H7/86)]

Definition statement

This subclass/group covers:

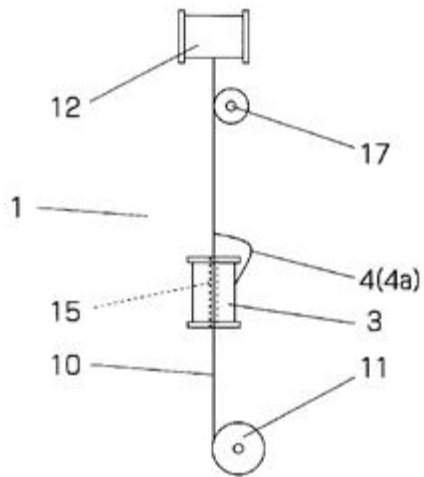

WO-A-2010/064647

D02G 3/324

[N: using a drawing frame]

Definition statement

This subclass/group covers:

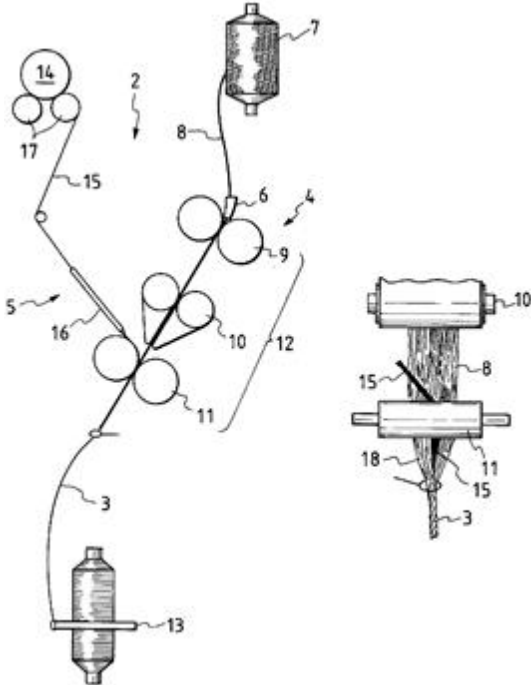

EP-A-0 548 474

D02G 3/34

Yarns or threads having slubs, knops, spirals, loops, tufts, or other irregular or decorative effects, i.e. effect yarns [N: (carding machines for producing decorative or fancy effects in products D01G; drafting machines with varying draft according to a pre-arranged pattern D01H5/36)]

Definition statement

This subclass/group covers:

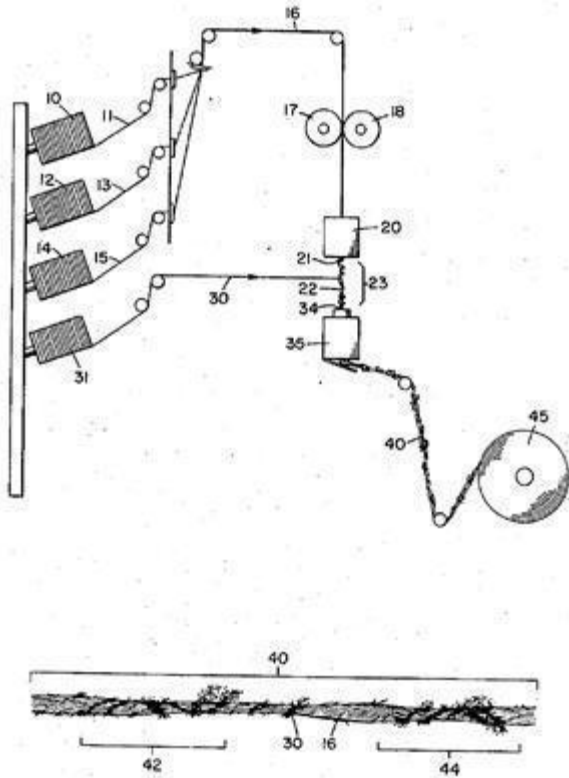

US-A-4 304 092

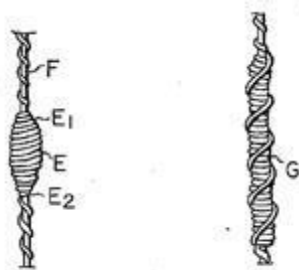

FR-A-2 315 554

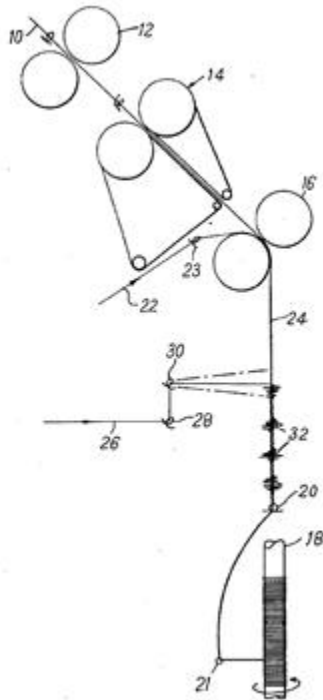

US-A-3 945 189

References relevant to classification in this group

This subclass/group does not cover:

Filamentary material with threaded or stringed pearls or beads	D04D 1/04
--	---------------------------

D02G 3/346

[N: with coloured effects, i.e. by differential dyeing process]

Informative references

Attention is drawn to the following places, which may be of interest for search:

Woven fabrics characterised by using coloured threads	D03D 15/0033
Passing of textile materials through liquids, gases or vapours to effect treatment of yarns, threads or filaments	D06B 3/04

D02G 3/36

Cored or coated yarns or threads ([N: D02G3/34, D02G3/40 take precedence]; elastic yarns or threads D02G3/32)

Definition statement

This subclass/group covers:

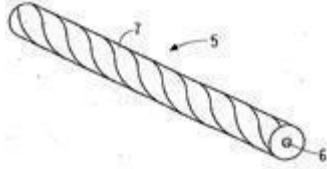

WO-A-01/98572

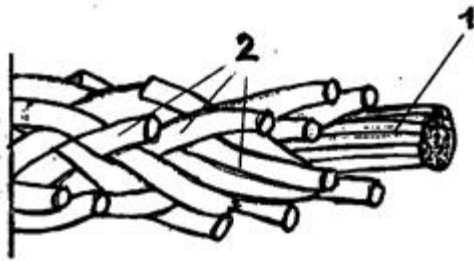

DE-U-202006008644

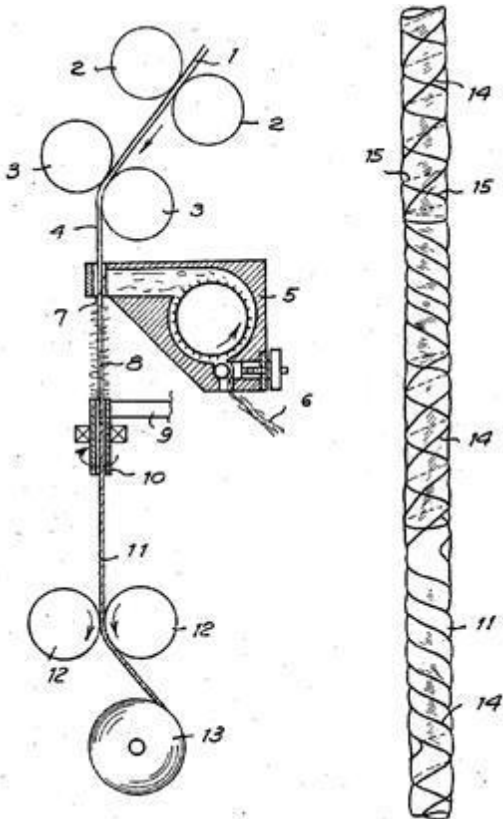

References relevant to classification in this group

This subclass/group does not cover:

Cored yarns or threads with an elastic core and/or sheath	D02G 3/32
---	---------------------------

D02G 3/365

[N: around which a reel supporting feeding spool rotates]

Definition statement

This subclass/group covers:

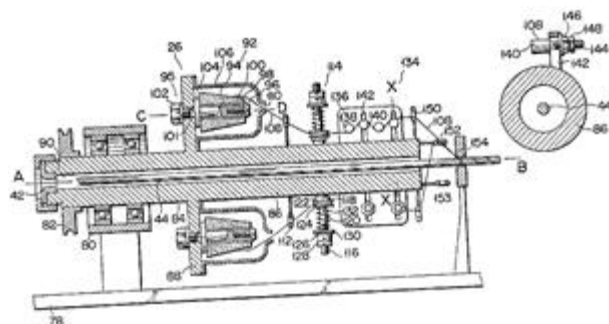

CH-A-607 246

D02G 3/38

Threads in which fibres, filaments, or yarns are wound with other yarns or filaments, [N: e.g. wrap yarns, i.e. strands of filaments or staple fibres are wrapped by a helically wound binder yarn; (D02G3/32 takes precedence)]; (covering endless core threads with fibres by using open-end spinning techniques D01H4/00)

Definition statement

This subclass/group covers:

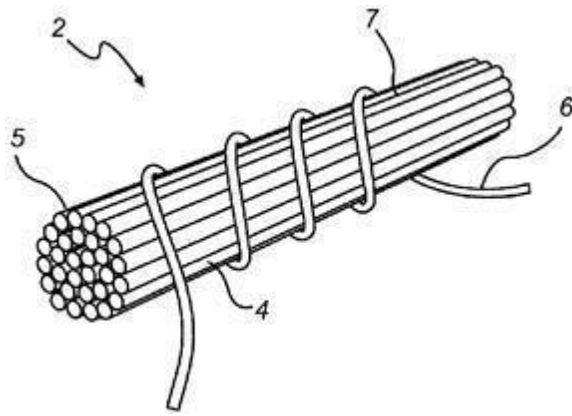

WO-A-2009037631

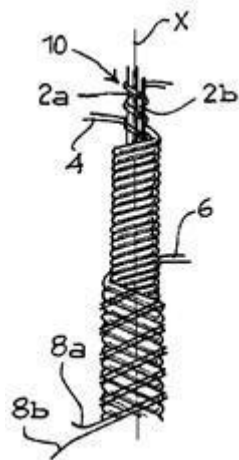

EP-A-1 964 952

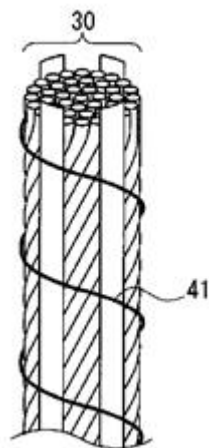

WO-A-2009/131149

D02G 3/40

Yarns in which fibres are united by adhesives; Impregnated

yarns or threads

Informative references

Attention is drawn to the following places, which may be of interest for search:

Passing of yarns, threads or filaments through liquids, gases or vapours to effect treatment	D06B 3/04
--	---------------------------

D02G 3/404

[N: Yarns or threads coated with polymeric solutions]

Informative references

Attention is drawn to the following places, which may be of interest for search:

Modifying the surface of filaments, yarns or threads by treating with particulate, semi-solid, or solid substances	D02J 3/18
--	---------------------------

D02G 3/406

[N: where the polymeric solution is removable at a later stage, e.g. by washing]

Definition statement

This subclass/group covers:

Yarns or threads coated with polymeric solutions removable at a later stage. The polymeric solution can also be in the form of a yarn, e.g. twisted or blended with other components of the yarn.

Informative references

Attention is drawn to the following places, which may be of interest for search:

Woven fabrics using scaffolding threads, i.e. threads removed after weaving	D03D 15/06
---	----------------------------

D02G 3/42

Chenille threads

Definition statement

This subclass/group covers:

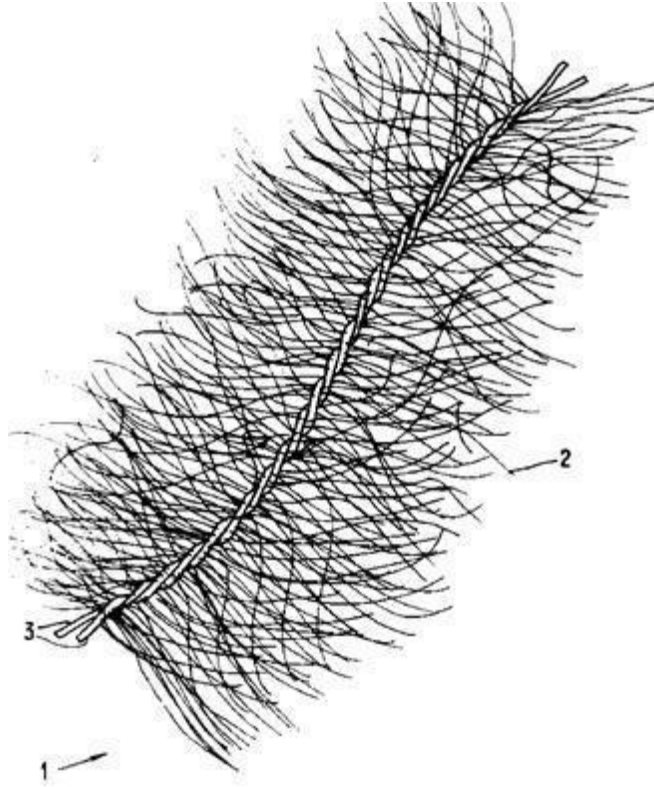

EP-A-0 620 185

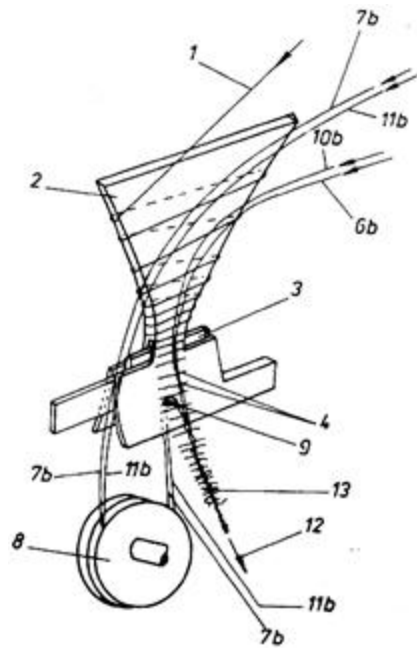

Informative references

Attention is drawn to the following places, which may be of interest for search:

Chenille fabrics	D03D 27/18
Chenille trimmings	D04D 3/00

Glossary of terms

In this subclass/group, the following terms (or expressions) are used with the meaning indicated:

Chenille yarn	is manufactured by placing short lengths of yarn, called the "pile", between two core yarns and then twisting the yarn together. The edges of these piles then stand at right angles from the yarn's core, giving the chenille both its softness and its characteristic look. Chenille will look different in one direction compared to another, as the fibres catch the light differently.
---------------	---

D02G 3/44

Yarns or threads characterised by the purpose for which they are designed [N: (protective gloves A41D19/00; protective clothing A62B17/00; ropes D07B1/02)]

Informative references

Attention is drawn to the following places, which may be of interest for search:

Professional, industrial or sporting protective garments	A41D 13/00
Woven fabrics characterised by the material of the yarn	D03D 15/00
Selection of special materials for outerwear	A41D 31/00

Fabrics or articles defined by weft knitting characterised by the thread material	D04B 1/14
Fabrics or articles defined by warp knitting characterised by the thread material	D04B 21/14

D02G 3/441

[N: Yarns or threads with antistatic, conductive or radiation-shielding properties (electroconductive, anti-static or radiation-shielding filaments D01F1/09, D01F1/106; anti-static fabrics D03D15/0005; conducting, insulating or anti-static layers for floor coverings D06N7/0042)]

Informative references

Attention is drawn to the following places, which may be of interest for search:

Threads containing metallic filaments or strips	D02G 3/12
Antistatic fabrics	D03D 15/0005
Flexible ohmic-resistance heating	H05B 3/34
Electromagnetic shielding materials comprising electro-conductive fibres	H05K 9/009
Car seat heating	B60N 2/5678
Special materials for outerwear against electric shocks or static electricity	A41D 31/0066

D02G 3/442

[N: Cut or abrasion resistant yarns or threads]

Informative references

Attention is drawn to the following places, which may be of interest for search:

Special materials for outerwear resistant to mechanical aggressions, e.g. pierceproof materials	A41D 31/0055
Protective gloves resistant to mechanical aggressions, e.g. cutting, piercing	A41D 19/01505

D02G 3/443

[N: Heat-resistant, fireproof or flame-retardant yarns or threads (fire- or flame-proof filaments D01F1/07; woven fabrics using heat-resistant or fireproof threads D03D15/12)]

Informative references

Attention is drawn to the following places, which may be of interest for search:

Woven fabrics using heat-resistant or fireproof threads	D03D 15/12
Special materials for outerwear against fire and heat	A41D 31/0022
Protective gloves with fire protection	A41D 19/01529
Fire resistant clothes	A62B 17/003

D02G 3/444

[N: Yarns or threads for use in sports applications (strings for tennis rackets A63B51/02)]

Definition statement

This subclass/group covers:

Yarns or threads for sport applications, including fishing lines and tennis racket strings made up of yarns.

Informative references

Attention is drawn to the following places, which may be of interest for search:

Fishing lines	A01K 91/00
---------------	----------------------------

Strings for tennis rackets	A63B 51/02
----------------------------	----------------------------

D02G 3/445

[N: Yarns or threads for use in floor fabrics (floor fabrics A47G27/00; floor coverings on textile basis D06N7/0005)]

Definition statement

This subclass/group covers:

Yarns or threads for use in floor fabrics, e.g. carpets, floor mats, artificial lawn.

Informative references

Attention is drawn to the following places, which may be of interest for search:

Artificial grass	E01C 13/08
Tufted carpets	D05C 17/02
Woven carpets	D03D 27/00

D02G 3/447

[N: Yarns or threads for specific use in general industrial applications, e.g. as filters or reinforcement]

Informative references

Attention is drawn to the following places, which may be of interest for search:

Extile reinforcements in driving belts	F16G 1/10
Textile reinforcement in V-belts	F16G 5/06
Packing materials shaped as strands, ropes, threads, ribbons or the like	F16J 15/22
Screen cloths and wire cloths in papermaking machines	D21F 1/0027 , D21F 1/10

D02G 3/449

[N: Yarns or threads with antibacterial properties (filaments containing agents inhibiting growth of micro-organisms D01F1/103)]

Informative references

Attention is drawn to the following places, which may be of interest for search:

Special materials for outerwear with antibacterial or antimicrobial materials	A41D 31/0077
Filaments containing agents inhibiting growth of micro-organisms	D01F 1/103

D02G 3/48

Tyre cords [N: (tyre reinforcements B60C9/00; metal cords for reinforcing rubber or plastic articles D07B1/0606)]

Definition statement

This subclass/group covers:

Textile tyre cords and hybrid tyre cords.

References relevant to classification in this group

This subclass/group does not cover:

Metal tyre cords	D07B 1/0606
------------------	-----------------------------

Informative references

Attention is drawn to the following places, which may be of interest for search:

Reinforcements or ply arrangement of pneumatic tyres	B60C 9/00
Driving belts made of fibrous material, e.g. textiles, whether rubber-covered or not	F16G 1/10 , F16G 1/28
V-belts made of rubber with textile reinforcement	F16G 5/08

Special rules of classification within this group

Hybrid cords (i.e. comprising metal wires and filaments or yarns within the same rope or strand) have to be classified in both [D02G 3/48](#) and [D07B 1/0606](#) or lower hierarchy.