

B21H

MAKING PARTICULAR METAL OBJECTS BY ROLLING, e.g. SCREWS, WHEELS, RINGS, BARRELS, BALLS (essentially from sheet metal B21D)

Definition statement

This subclass/group covers:

Methods and devices for forming metal objects by rolling operations which are not combined with further different metal-working operations.

Informative references

Attention is drawn to the following places, which may be of interest for search:

Attention is drawn to the following places, which might be of interest for search:

Continuous rolling of semi-finished products (e.g. continuous rolling of metal strip, wire or tubes in rolling mills)	B21B
Roll-forming (i.e. consecutive bending) of metal sheet	B21D 5/06

B21H 1/00

Making articles shaped as bodies of revolution (rolling tubes B21B17/00 to B21B25/00)

Definition statement

This subclass/group covers:

Methods and devices for manufacturing rotationally symmetric bodies.

References relevant to classification in this group

This subclass/group does not cover:

Rolling of threads or gear profiles onto cylindrical bodies	B21H 3/02 , B21H 5/00
---	---

Informative references

Attention is drawn to the following places, which may be of interest for search:

Attention is drawn to the following places, which might be of interest for search:

Flanging of tubes by rolling	B21D 19/04
Rolling tubes	B21B 17/00 to B21B 25/00

B21H 1/18

cylinders, e.g. rolled transversely [N: cross-rolling]

Definition statement

This subclass/group covers:

Cross-rolling of cylindrical workpieces with rollers having an axis of rotation parallel to the axis of the workpiece. In most cases recesses are formed on the workpiece by a profile on the rollers which varies in width.

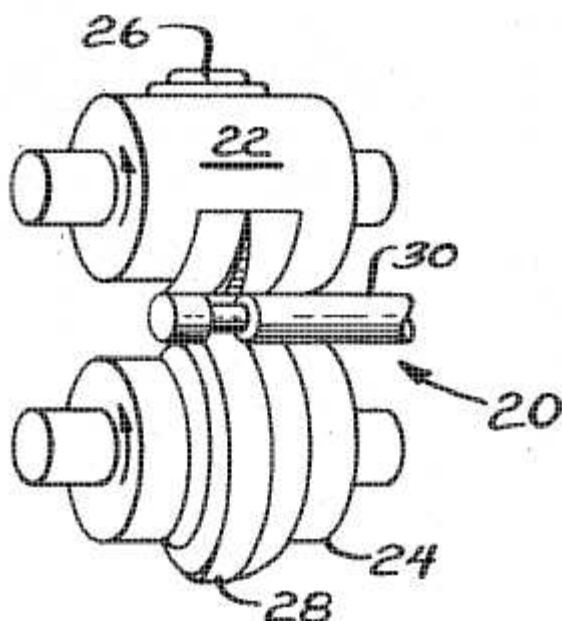

(from US 4459880 (A))

References relevant to classification in this group

This subclass/group does not cover:

Manufacturing of gear toothing by rollers having an axis of rotation parallel to the axis of the workpiece	B21H 5/02
--	---------------------------

Informative references

Attention is drawn to the following places, which may be of interest for search:

Spinning	B21D 22/14
----------	----------------------------

B21H 1/20

rolled longitudinally

Definition statement

This subclass/group covers:

Forming of profiles or reduction in cross-section by rollers or roller-segments having an axis of rotation not parallel to the axis of the workpiece.

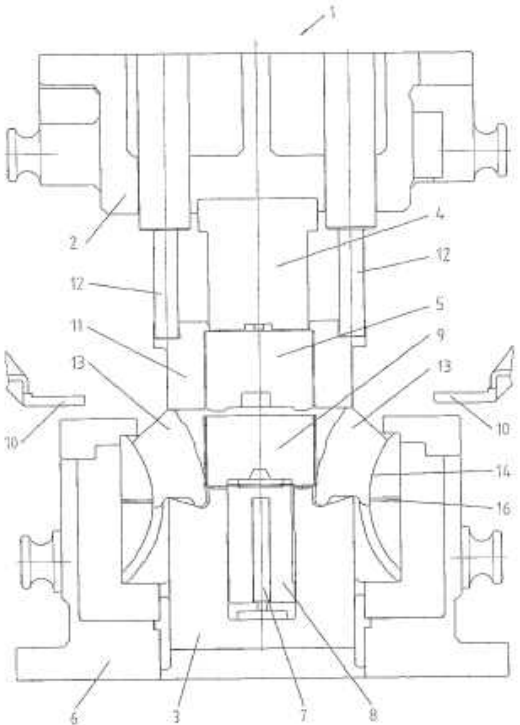
Forming of profiles with roller-segments	 <p>(from WO 2007137543 (A1))</p>
Reduction in cross-section	

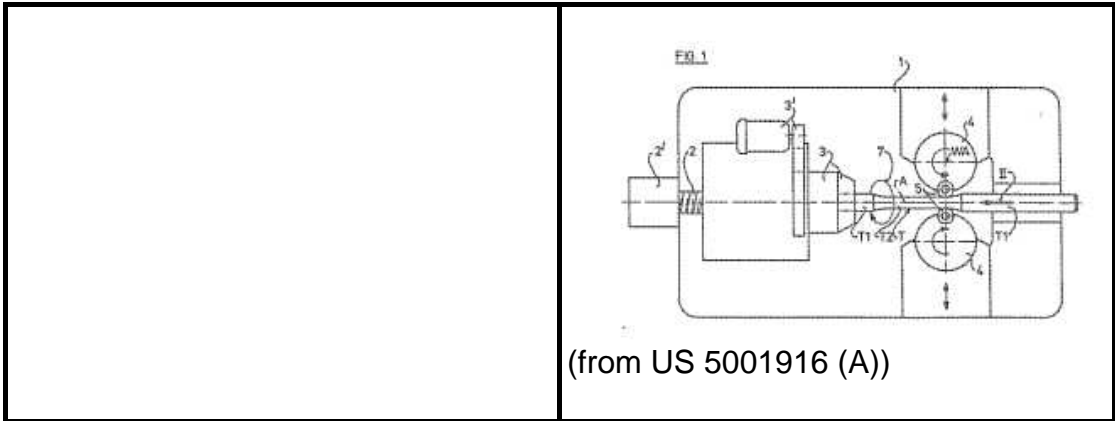

Informative references

Attention is drawn to the following places, which may be of interest for search:

Continuous reduction in cross-section of workpieces	B21B
---	----------------------

B21H 1/22

characterised by use of rolls having circumferentially varying profile; [N: Die-rolling]

Definition statement

This subclass/group covers:

Forming of profiles or reduction in cross-section with the help of rollers or roller-segments comprising a die

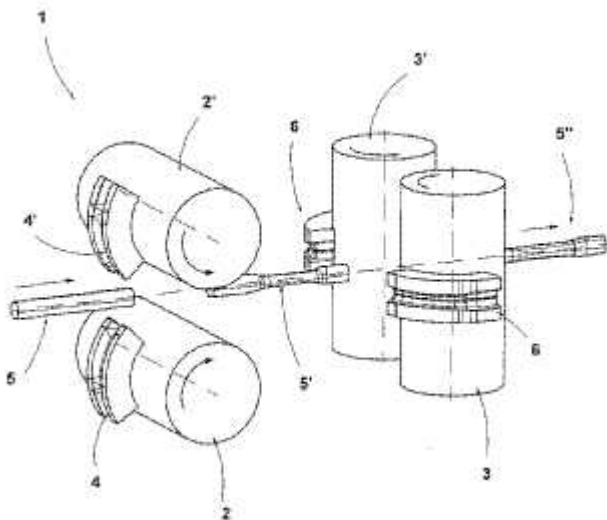

(from DE 102004016193 (A1))

Informative references

Attention is drawn to the following places, which may be of interest for search:

Cross-rolling of cylindrical workpieces	B21H 1/18
---	---------------------------

B21H 3/00

Making helical bodies or bodies having parts of helical shape (helical gears B21H5/00; forming tubes or tube walls into helical shape B21D11/06, B21D15/04)

Definition statement

This subclass/group covers:

Methods and devices for forming a helical structure like a thread or helical flutes on a body by a chipless rolling process. The group covers plastic deformation of the metal body to produce a thread structure without cutting or milling and includes cold thread rolling (swaging).

Informative references

Attention is drawn to the following places, which may be of interest for search:

Forming of helical structures on a body by forging or pressing	B21K 1/56 , B21K 5/02
Making helical gears, i.e. worms	B21H 5/00
Bending of a body into helical form	B21D 11/06
Corrugating tubes helically	B21D 15/04
Coiling wire helically	B21F 3/02
Screws	F16B
Self-tapping screws	F16B 25/00
Locking screws	F16B 39/30
Screws having a special thread-form	F16B 33/02

B21H 3/04

Making by means of profiled-rolls [N: or die rolls]

Definition statement

This subclass/group covers:

Methods and devices in which the external screw-thread is manufactured by means of profiled rolls, but which do not comprise or further specify the use of a thread rolling head.

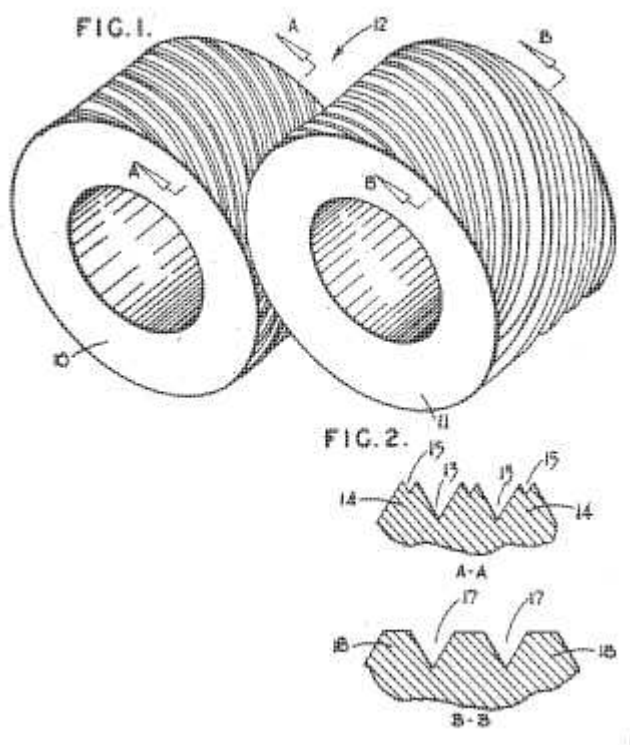

(from GB 999785 (A))

References relevant to classification in this group

This subclass/group does not cover:

Profiled rolls for making gear wheels	B21H 5/00
---------------------------------------	---------------------------

B21H 3/042

[N: Thread-rolling heads]

Definition statement

This subclass/group covers:

Handtools for rolling a thread on a workpiece. General aspects of thread rolling heads and methods of using a thread rolling head not related to a special type of thread-rolling head.

B21H 3/044

[N: working axially]

Definition statement

This subclass/group covers:

Axial thread rolling methods and devices for forming external screw-threads using a thread-rolling head working axially, i.e. the rollers have a continuous and constant profile about their circumference and run axially along the workpiece. During rolling the workpiece passes through an axial bore within the rolling head.

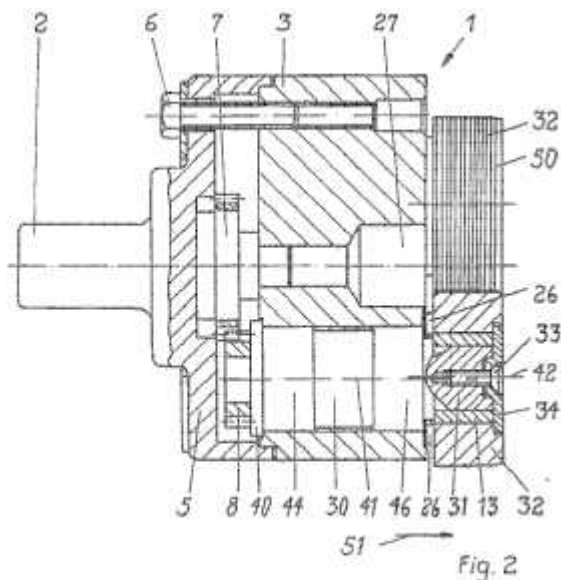

(from EP 0417416 (A2))

B21H 3/046

[N: working radially]

Definition statement

This subclass/group covers:

Radial thread-rolling methods and devices, the thread-rolling head forming a thread in one single rotation of either the workpiece within the rollers or the rolling head about the workpiece. The rollers are provided with a

circumferentially varying profile and/or are eccentrically mounted within the rolling head. The workpiece is inserted axially into the rolling head. After insertion of the workpiece the rollers approach the workpiece radially.

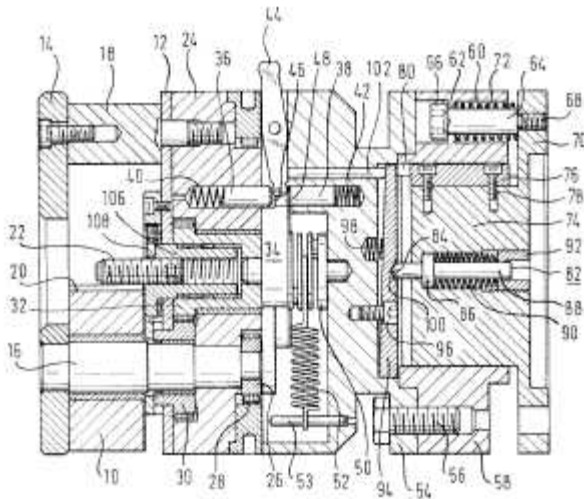

(from US 5924317 (A))

B21H 3/048

[N: working tangentially]

Definition statement

This subclass/group covers:

Tangential thread-rolling methods and devices, the thread-rolling head being fed tangentially against the rotating workpiece.

In order to allow a tangential insertion of the workpiece into the rolling head, the radial distance between the rollers can be varied. Some rolling heads comprise rollers having a varying circumferential profile in order to allow the insertion of the workpiece.

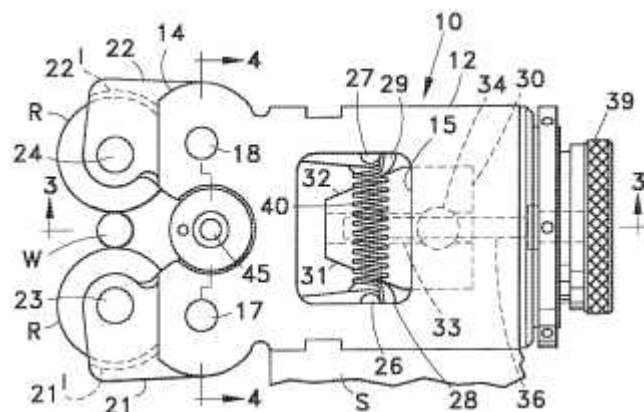

(from US 6202461 (B1))

B21H 3/06

Making by means of profiled members other than rolls, e.g. [N: reciprocating flat dies or] jaws, moved longitudinally or curvilinearly with respect to each other

Definition statement

This subclass/group covers:

Rolling of threads by means of reciprocating flat dies, wherein the dies are reciprocated in relation to one another or a stationary die is provided and the other die is reciprocated.

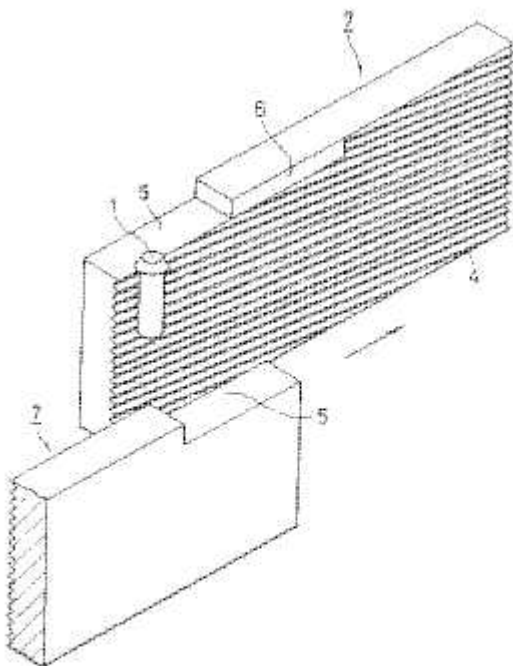

(from JP 62158541 (A))

Informative references

Attention is drawn to the following places, which may be of interest for search:

Rolling of cylindrical gears by means of reciprocating flat dies	B21H 5/027
--	----------------------------

B21H 3/065

[N: Planetary thread rolling]

Definition statement

This subclass/group covers:

Planetary thread rolling methods and devices, i.e. rolling of threads between a stationary and a rotatable die.

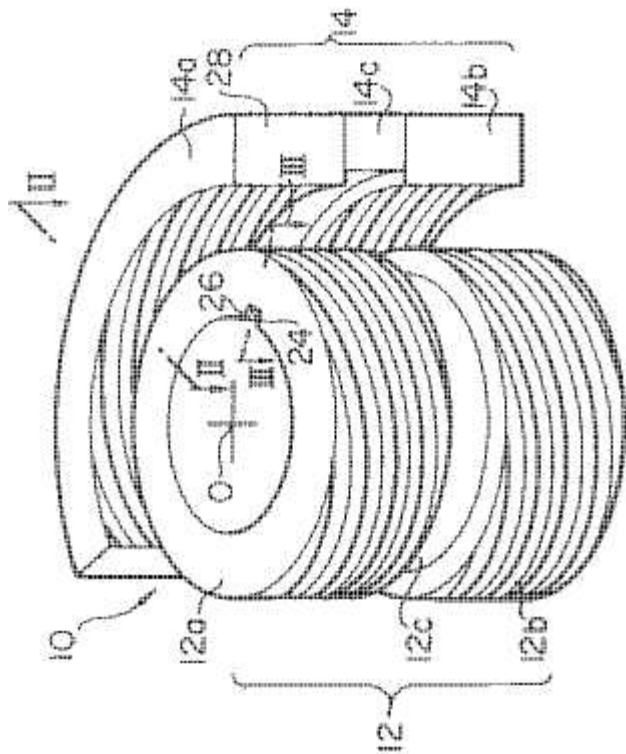

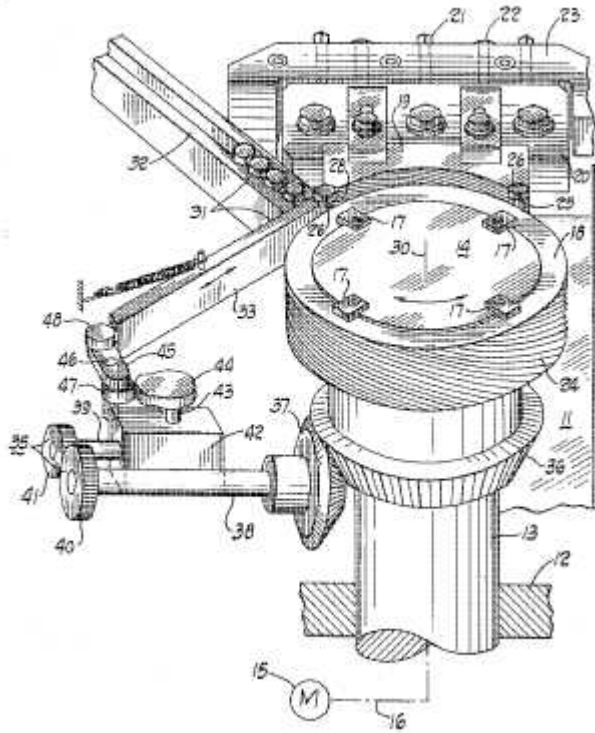

(from JP 57094439 (A)) (from US 3733867 (A))

B21H 3/12

articles with helicoidal surface (bending strip or the like helically B21D11/06)

Definition statement

This subclass/group covers:

Methods and devices for forming a helical structure like helical fins on a workpiece by rolling, including a workpiece that is rotated and longitudinally moved relative to rolling dies or the dies are rotated and the workpiece is longitudinally moved relative to rolling dies without rotation.

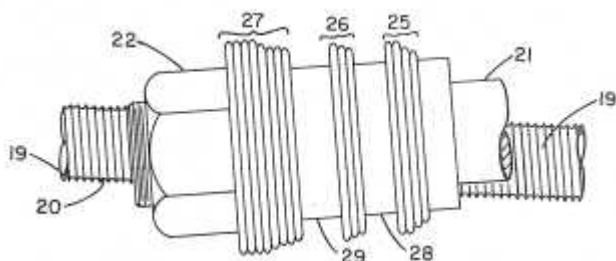

(from US 3745801 (A))

Informative references

Attention is drawn to the following places, which may be of interest for search:

Manufacturing of helical gear worms	B21H 5/005
-------------------------------------	----------------------------

B21H 5/00

Making gear wheels, [N: racks, spline shafts or worms]

Definition statement

This subclass/group covers:

Methods and devices for manufacturing or finishing geared workpieces by a chipless rolling process. This group does not only cover the manufacturing or finishing of gear wheels, but also of racks, spline shafts and worms.

Informative references

Attention is drawn to the following places, which may be of interest for search:

Manufacturing of gear wheels by forging or pressing	B21K 1/30
Manufacturing of toothed racks by forging or pressing	B21K 1/767
Making gear wheels by other methods	B23P 15/14
Making gears or toothed racks by other methods	B23F

B21H 5/005

[N: Worms]

Definition statement

This subclass/group covers:

Making work wheels or gears with a helical toothing

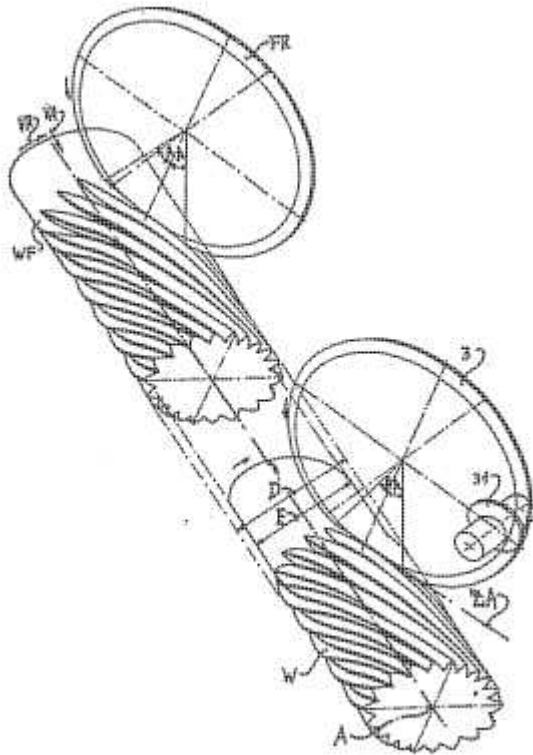

(from CH 668726 (A5))

Informative references

Attention is drawn to the following places, which may be of interest for search:

Toothed members, worms	F16H 55/02
------------------------	----------------------------

B21H 5/02

with cylindrical outline, [N: e.g. by means of die rolls (worms B21H5/005)]

Definition statement

This subclass/group covers:

Methods and devices for manufacturing external gear toothing on cylindrical workpieces by means of die rolls.

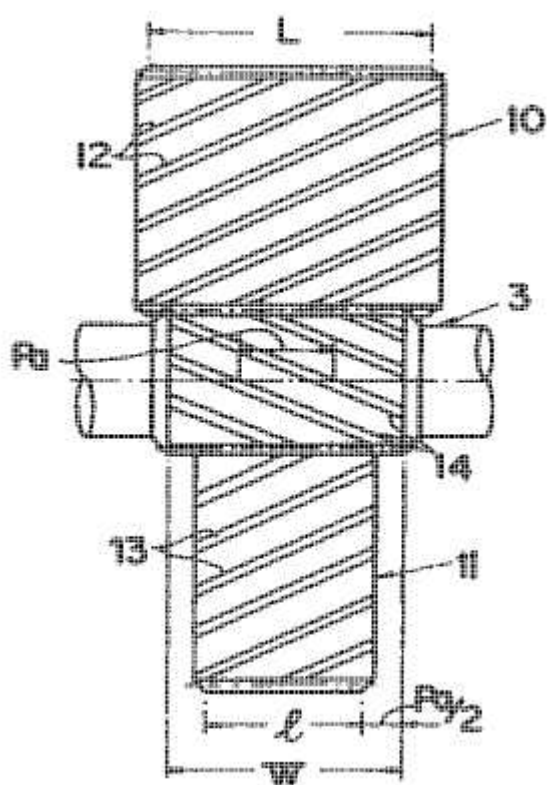

(from JP 59209451 (A))

Informative references

Attention is drawn to the following places, which may be of interest for search:

Finishing of preformed gear wheels	B21H 5/022
Making of internal gear wheels by rolling	B21H 5/025
Manufacturing of gear wheels by means of flat dies	B21H 5/027
Rolling of bevel gears	B21H 5/04
Spinning in order to manufacture other products than gear wheels	B21D 22/14

B21H 5/022

[N: Finishing gear teeth with cylindrical outline, e.g.

burnishing]

Definition statement

This subclass/group covers:

Methods and devices for finish-rolling of preformed gear wheels, in particular of sintered gear wheels, by rolling or burnishing, including compacting of sintered powder gearing teeth by rolling.

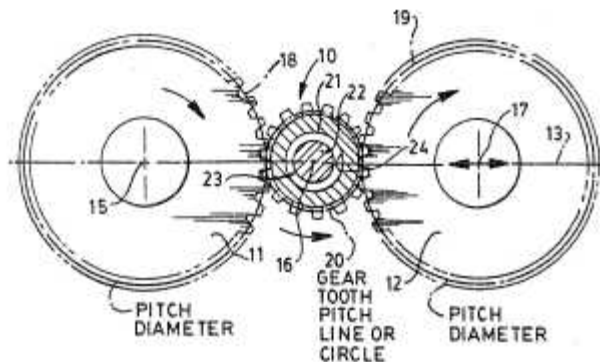

(from US 5230234 (A))

Informative references

Attention is drawn to the following places, which may be of interest for search:

Rolling of tothing into cylindrical blanks without preformed gear teeth	B21H 5/02
Finishing gear teeth by other tools	B23F 19/00

B21H 5/025

[N: Internally geared wheels]

Definition statement

This subclass/group covers:

Methods and devices for manufacturing internal gear tothing on cylindrical workpieces. This subgroup also covers the manufacturing of such gears by spinning or by the so-called "Grob"-process, in which eccentrically mounted rollers hit the workpiece

Manufacturing of internal gear tothing by rolling	
---	--

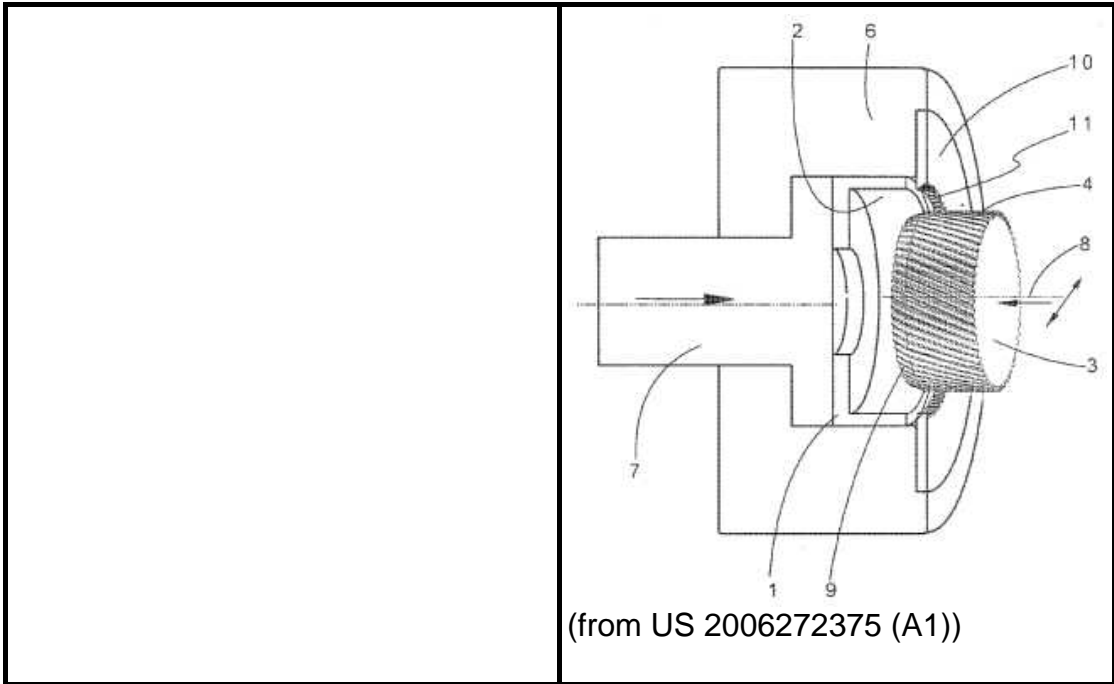

Manufacturing of internal gear tooting by spinning

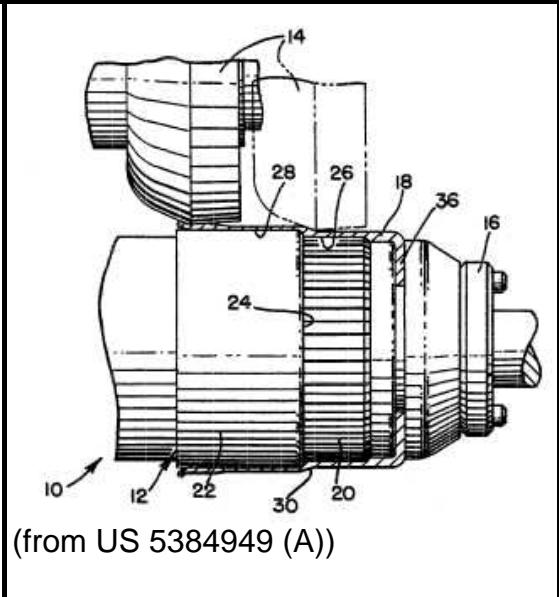

Manufacturing of internal gear tooting by the "Grob"-process

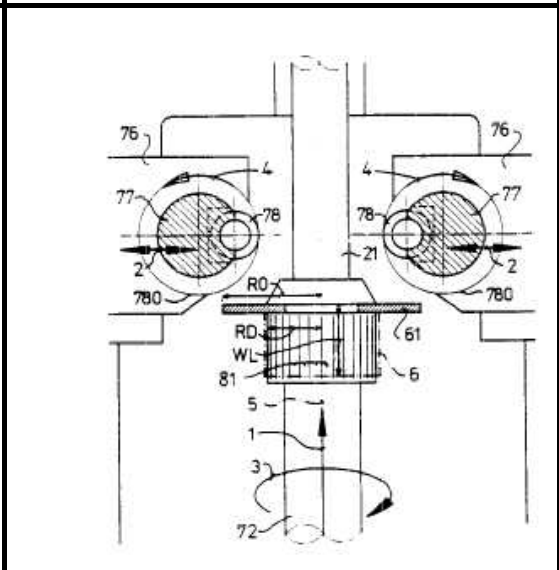

	(from DE 4315503 (A1))
--	------------------------

Informative references

Attention is drawn to the following places, which may be of interest for search:

Attention

is drawn to the following places, which may be of interest for search:

Rolling of external tothing into cylindrical blanks without preformed gear teeth	B21H 5/02
--	---------------------------

B21H 5/027

[N: by rolling using reciprocating flat dies, e.g. racks
(B21H5/022 takes precedence)]

Definition statement

This subclass/group covers:

Manufacturing of gear teeth on a workpiece by relatively reciprocating flat dies or racks.

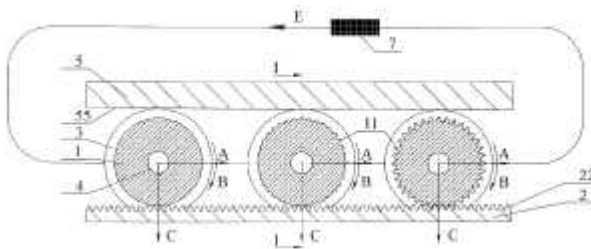

(from WO 2004022259 (A1))

Informative references

Attention is drawn to the following places, which may be of interest for search:

Manufacturing of external threads on a workpiece by means of reciprocating flat dies	B21H 3/06
--	---------------------------

B21H 5/04

bevel gears

Definition statement

This subclass/group covers:

Methods and devices for rolling bevel gears.

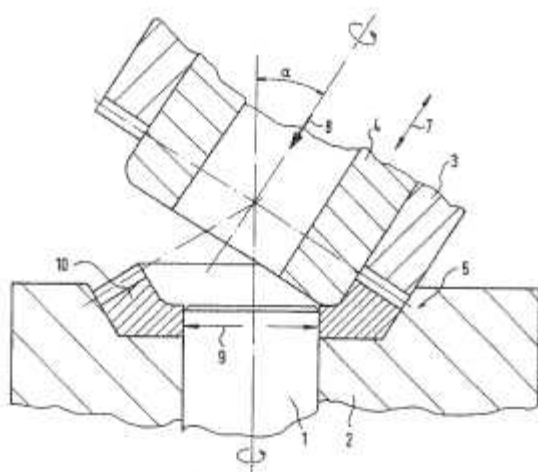

(from US 6076387 (A))

B21H 7/00

Making articles not provided for in the preceding groups, e.g. agricultural tools, dinner forks, knives, spoons (nails, pins B21G3/30)

Definition statement

This subclass/group covers:

Methods and devices for manufacturing particular articles by rolling.

Informative references

Attention is drawn to the following places, which may be of interest for search:

Making particular articles by forging or pressing	B21K
Making of needles, pins and nails	B21G
Making particular articles by working sheet metal	B21D

Making particular articles from wire	B21F
Making specific metal objects by operations not covered by a single other subgroup	B23P 15/00

B21H 7/18

grooved pins; Rolling grooves, e.g. oil grooves, in articles [N: (B21H5/00 takes precedence)]

Definition statement

This subclass/group covers:

Rolling grooves like oil grooves in general.

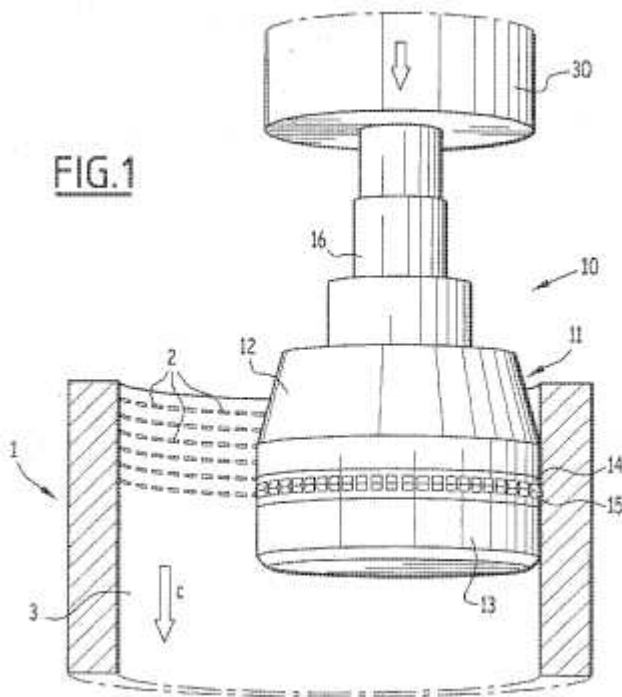

(from EP 1405689 (A1)=

B21H 7/182

[N: Rolling annular grooves]

Definition statement

This subclass/group covers:

Methods and devices for forming annular grooves in a workpiece by rolling.

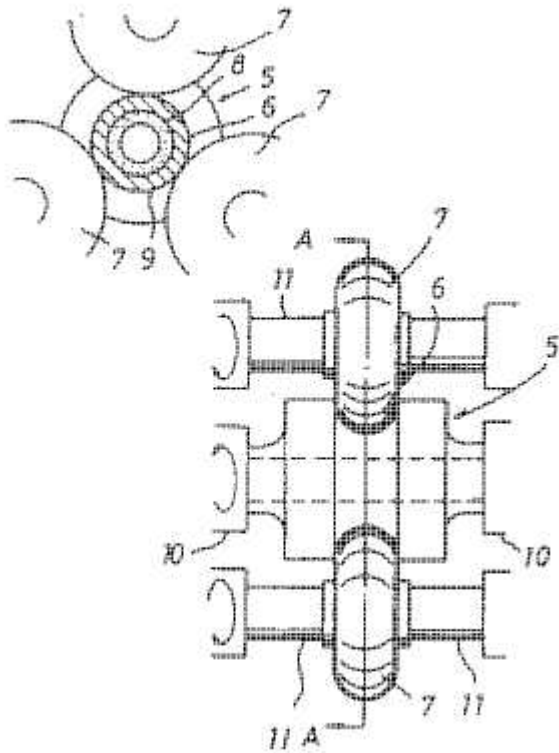

(from JP 57036033 (A))

B21H 7/185

[N: Fillet rolling e.g. of crankshafts]

Definition statement

This subclass/group covers:

Methods and devices for finishing, i.e. burnishing, of annular grooves by rolling, in particular for deep rolling of crankshaft fillets.

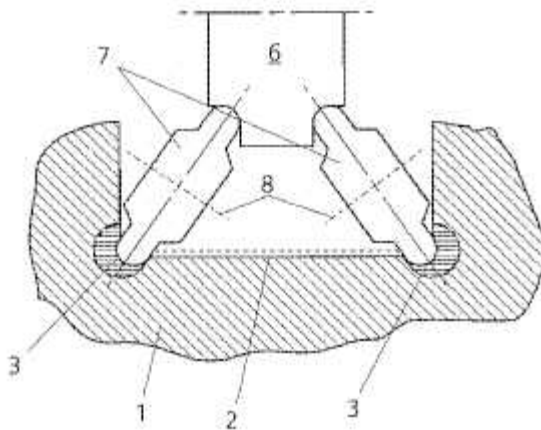
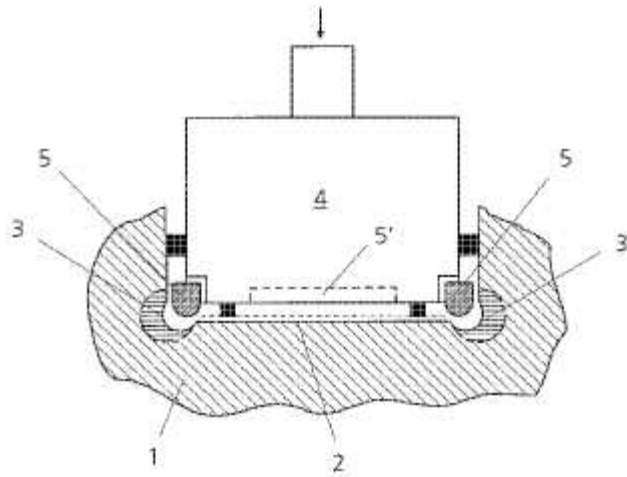

(from WO 2006119944 (A1))

Informative references

Attention is drawn to the following places, which may be of interest for search:

Burnishing machines or devices	B24B 39/00
--------------------------------	----------------------------

B21H 7/187

[N: Rolling helical or rectilinear grooves]

Definition statement

This subclass/group covers:

Methods and devices for forming helical or rectilinear grooves in a workpiece by rolling.

Rolling of helical grooves	21
----------------------------	----

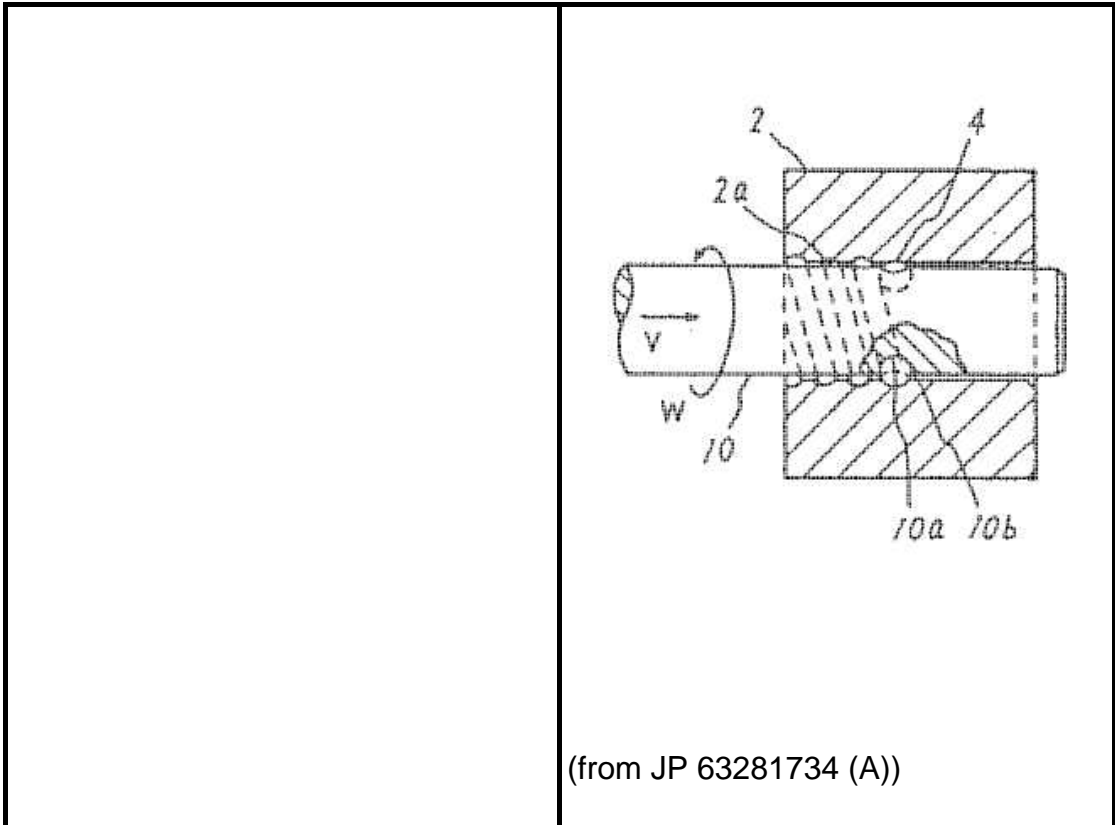

(from JP 63281734 (A))

Rolling of rectilinear grooves

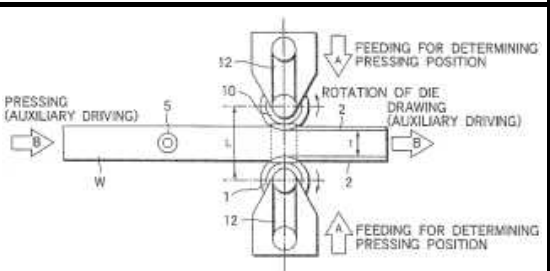

(from US 2003070465 (A1))

Informative references

Attention is drawn to the following places, which may be of interest for search:

Making worms by rolling	B21H 5/005
Making articles with helicoidal surface by rolling	B21H 3/12

B21H 8/00

Rolling metal of indefinite length in repetitive shapes specially designed for the manufacture of particular objects [N: e.g.

checkered sheets]

Definition statement

This subclass/group covers:

Methods and devices for forming repetitive structures on a workpiece by rolling.

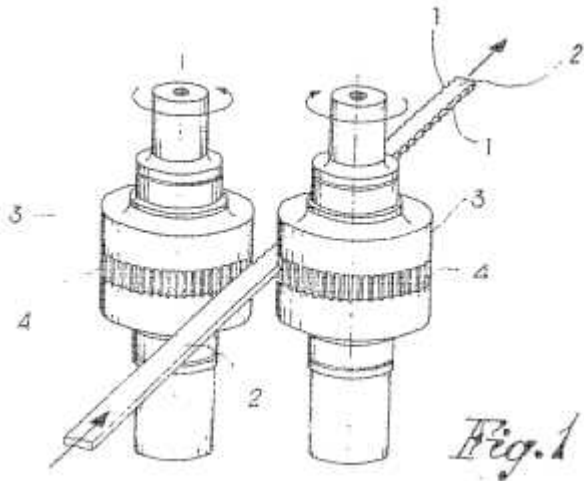

(from GB 2135613 (A))

B21H 8/005

[N: Embossing sheets or rolls]

Definition statement

This subclass/group covers:

Methods and devices for roll embossing or roll stamping of workpieces, i.e. for impressing a discrete pattern into a sheet, strip or roll of metal, often for creating a decorative pattern.

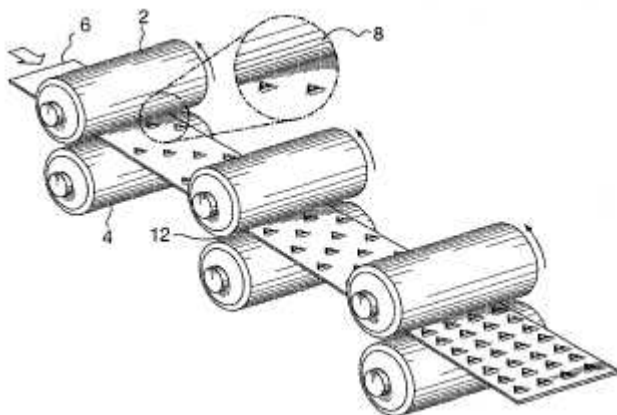

(from EP 1819460 (A1))

Informative references

Attention is drawn to the following places, which may be of interest for search:

Surface roughening or texturing within a rolling mill	B21B 1/22
Rolls with a roughened or textured surface; methods for making the same	B21B 27/00
Machines and rolls for embossing decorations	B44B 5/00
Pressing or stamping ornamental designs	B44C 1/24

B21H 9/00

Feeding arrangements for rolling machines or apparatus manufacturing articles dealt with in this subclass

Definition statement

This subclass/group covers:

Methods and devices for feeding blanks to be rolled into or extracting rolled workpieces from a rolling device.