

F02D

CONTROLLING COMBUSTION ENGINES (cyclically operating valves for combustion engines [F01L](#); controlling combustion engine lubrication [F01M](#); cooling internal combustion engines [F01P](#); supplying combustion engines with combustible mixtures or constituents thereof, e.g. carburettors, injection pumps [F02M](#); starting of combustion engines [F02N](#); controlling of ignition [F02P](#); controlling gas-turbine plants, jet-propulsion plants, or combustion-product engine plants, see the relevant subclasses for these plants)

References

Informative references

Attention is drawn to the following places, which may be of interest for search:

Automatic controllers for prime movers, in general	G05D
--	----------------------

Glossary of terms

In this place, the following terms or expressions are used with the meaning indicated:

Engine	"engine" means a device for continuously converting fluid energy into mechanical power. Thus, this term includes, for example, internal-combustion piston engines, but it excludes single-stroke devices
--------	--

F02D 1/00

Controlling fuel-injection pumps, e.g. of high pressure injection type ([F02D 3/00](#) takes precedence; controlling fuel-injection electrically [F02D 41/30](#) {pumping elements on fuel pressure acting for varying fuel delivery in quantity or timing [F02M](#)})

Definition statement

This place covers:

Controlling fuel-injection pumps, e.g. of the high pressure injection type and pertains in particular to mechanical controlling and linkage of mechanically controlled fuel injection pumps.

References

Limiting references

This place does not cover:

Controlling low-pressure fuel injection by means other than controlling only an injection pump	F02D 3/00
--	---------------------------

Application-oriented references

Examples of places where the subject matter of this place is covered when specially adapted, used for a particular purpose, or incorporated in a larger system:

Peculiar to engines characterised by their use of non-liquid fuels, pluralities of fuels, or non-fuel substances added to the combustible mixtures	F02D 19/00
Peculiar to supercharged engines	F02D 23/00

Informative references

Attention is drawn to the following places, which may be of interest for search:

Controlling combustion engines	F02D
Controlling pumps peculiar to engines characterised by their use of non-liquid fuels, pluralities of fuels, or non-fuel substances added to the combustible mixtures	F02D 19/00
Controlling supercharged engines	F02D 23/00
Controlling fuel-injection electrically	F02D 41/30
Cyclically operating valves for combustion engines	F01L
Controlling combustion engine lubrication	F01M
Cooling internal combustion engines	F01P
Supplying combustion engines with combustible mixtures or constituents thereof, e.g. carburettors, injection pumps	F02M
Control of modern common rail fuel pumps	F02M 59/20
Starting of combustion engines	F02N
Controlling of ignition	F02P
Automatic controllers for prime movers, in general	G05D
Controlling gas-turbine plants, jet-propulsion plants, or combustion-product engine plants	see the relevant subclasses for these plants.

F02D 1/162

{by mechanical means dependent on engine speed for angular adjustment of driving and driven shafts}

Definition statement

This place covers:

E.g. using a centrifugal governor to adjust the angular timing of pump shaft.

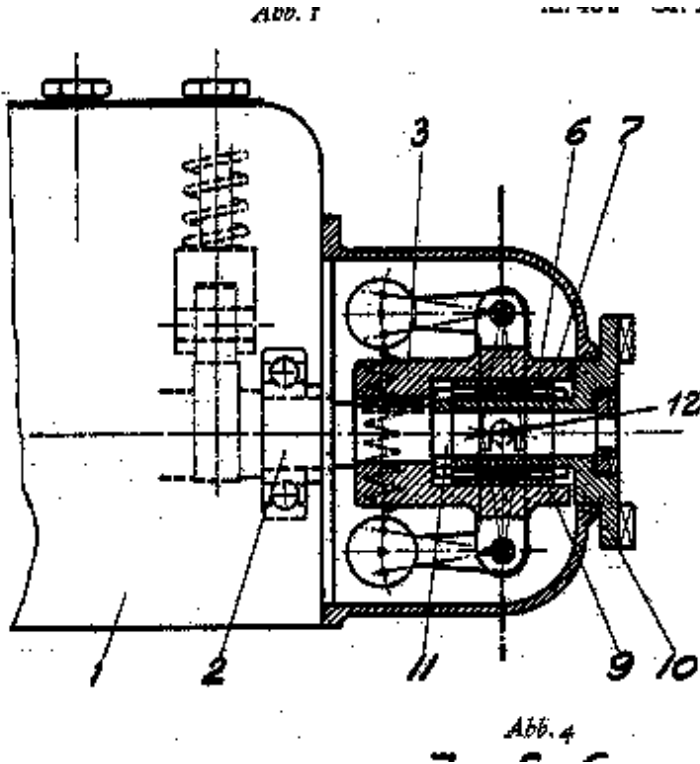

F02D 1/183

{hydraulic}

Definition statement*This place covers:*

Hydraulic adjustment of injection timing. E.g. using a hydraulic phase shifter device between pump and pump drive or angularly adjusting a cam profile to adjust the timing.

EP 0 487 087 A1

Fig. 1

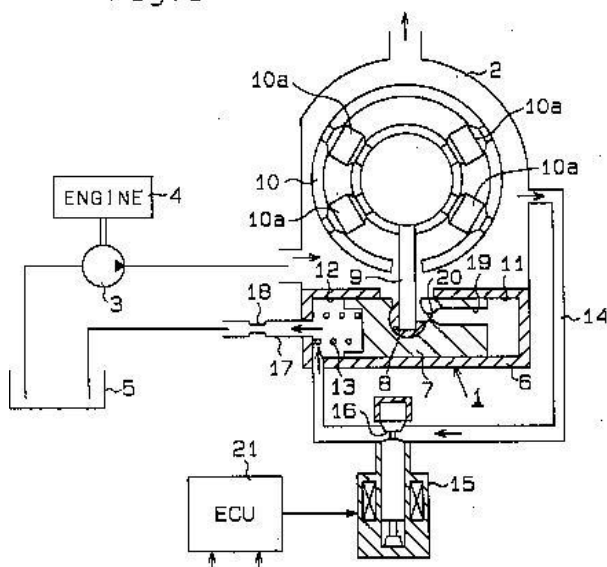
**F02D 3/00**

Controlling low-pressure fuel injection, i.e. where the air-fuel mixture containing fuel thus injected will be substantially compressed by the compression stroke of the engine, by means other than controlling only an injection pump (controlling fuel-injection electrically [F02D 41/30](#); {controlling the feeding of liquid fuel from storage containers to carburettors or fuel-injection apparatus [F02D 33/003](#); } carburettors [F02M](#))

References**Limiting references***This place does not cover:*

Controlling, e.g. regulating, fuel injection peculiar to engines characterised by their use of non-liquid fuels, pluralities of fuels, or non-fuel substances added to the combustible mixtures	F02D 19/00
Controlling fuel-injection electrically	F02D 41/30
Carburettors	F02M

Application-oriented references

Examples of places where the subject matter of this place is covered when specially adapted, used for a particular purpose, or incorporated in a larger system:

Peculiar to engines characterised by their use of non-liquid fuels, pluralities of fuels, or non-fuel substances added to the combustible mixtures	F02D 19/00
Peculiar to supercharged engines	F02D 23/00

Informative references

Attention is drawn to the following places, which may be of interest for search:

Controlling supercharged engines	F02D 23/00
Cyclically operating valves for combustion engines	F01L
Controlling combustion engine lubrication	F01M
Cooling internal combustion engines	F01P
Supplying combustion engines with combustible mixtures or constituents thereof, e.g. carburettors, injection pumps	F02M
Low pressure fuel-injection apparatus	F02M 69/00
Starting of combustion engines	F02N
Controlling of ignition	F02P

F02D 7/00**Other fuel-injection control****References****Limiting references**

This place does not cover:

Control of fuel injection peculiar to engines characterised by their use of non-liquid fuels, pluralities of fuels, or non-fuel substances added to the combustible mixtures	F02D 19/00
Control of supercharged engines	F02D 23/00
Electric fuel-injection control	F02D 41/00

Application-oriented references

Examples of places where the subject matter of this place is covered when specially adapted, used for a particular purpose, or incorporated in a larger system:

Peculiar to engines characterised by their use of non-liquid fuels, pluralities of fuels, or non-fuel substances added to the combustible mixtures	F02D 19/00
Peculiar to supercharged engines	F02D 23/00

Informative references

Attention is drawn to the following places, which may be of interest for search:

Cyclically operating valves for combustion engines	F01L
Controlling combustion engine lubrication	F01M
Cooling internal combustion engines	F01P
Supplying combustion engines with combustible mixtures or constituents thereof, e.g. carburettors, injection pumps	F02M
Starting of combustion engines	F02N
Controlling of ignition	F02P
Automatic controllers for prime movers, in general	G05D

F02D 7/02**Controlling fuel injection where fuel is injected by compressed air****References****Informative references**

Attention is drawn to the following places, which may be of interest for search:

Apparatus for injecting fuel by means of high pressure gas	F02M 67/00
Apparatus for low pressure fuel injection by compressed air	F02M 69/08

F02D 9/00**Controlling engines by throttling air or fuel-and-air induction conduits or exhaust conduits****Definition statement**

This place covers:

Valves for controlling the air or air and fuel admission into or the exhaust out of the engine and the arrangement of such valves in intake or exhaust conduits.

Relationships with other classification places

General aspects of valves can be found in [F16K](#)

References**Limiting references**

This place does not cover:

Lift valves	F01L 3/00
EGR valves	F02M 26/52
Lift valves in general	F16K 1/00

Informative references

Attention is drawn to the following places, which may be of interest for search:

Valves in general	F16K
-------------------	----------------------

Glossary of terms

In this place, the following terms or expressions are used with the meaning indicated:

Pivotally-mounted flaps	Flaps rotating around an axis
-------------------------	-------------------------------

Synonyms and Keywords

In patent documents, the following words/expressions are often used as synonyms:

- "butterfly valve" and "pivotally-mounted flap valve"

F02D 11/00

Arrangements for, or adaptations to, non-automatic engine control initiation means, e.g. operator initiated (specially for reversing [F02D 27/00](#); arrangement or mounting of prime-mover control devices in vehicles [B60K 26/00](#))

Definition statement

This place covers:

Hand- and/or foot pedal operated engine control initiation means and control linkages between the hand and/or foot pedal and the controlled device, e.g. throttle valve, carburettor or fuel injector. The control linkage can be mechanical, e.g. combined with power drive assistance, or non-mechanical, e.g. hydraulic linkage e.g. combined with power drive assistance.

Relationships with other classification places

Electronic engine control in general, [F02D](#)

References**Limiting references**

This place does not cover:

Electronic engine control initiation means	F02D 11/10
Engine control initiation means for reversing	F02D 27/00
Arrangement or mounting of prime-mover control devices in vehicles	B60K 26/00

Informative references

Attention is drawn to the following places, which may be of interest for search:

Arrangements or mounting of propulsion unit control devices in vehicles	B60K 26/00
Controlling members, e.g. knobs or handles; assemblies or arrangements thereof;	G05G 1/00

Glossary of terms

In this place, the following terms or expressions are used with the meaning indicated:

Power drive assistance	Drive assistance for hand or foot
------------------------	-----------------------------------

Synonyms and Keywords

In patent documents, the following words/expressions are often used as synonyms:

- "prime mover" and "engine"

F02D 11/10

of the electric type

Definition statement

This place covers:

Mechanical aspects/construction of electric throttles; Links between throttle and pedal as long as it concerns the electrical aspects, or the mechanical linking of the motor to the rest, e.g. clutch etc.

F02D 11/105

{characterised by the function converting demand to actuation, e.g. a map indicating relations between an accelerator pedal position and throttle valve opening or target engine torque}

Definition statement

This place covers:

Throttles characterised by the function of linking demand to actuation using:

- Different response curves between pedal and throttle, combination of pedal (or cable) displacement and motor movement, free gaps
- Torque control, i.e. conversion accelerator position -> torque demands -> actuator commands

F02D 11/106

{Detection of demand or actuation}

Definition statement

This place covers:

Detection of throttle position or accelerator position

References

Informative references

Attention is drawn to the following places, which may be of interest for search:

Sensors to detect relative movements	G01D 5/12
Pedal position sensors	G05G 1/38

F02D 13/00

Controlling the engine output power by varying inlet or exhaust valve operating characteristics, e.g. timing (modifying valve gear [F01L](#))

Definition statement

This place covers:

Controlling the engine output power by varying inlet or exhaust valve operating characteristics, e.g. timing. The inlet and exhaust valves within an internal combustion engine are used to control the flow of the intake and exhaust gases into and out of the combustion chamber. The timing, duration and lift of these valve has a significant impact on engine performance. In a standard engine, the valve events are fixed, so performance at different loads and speeds is always a compromise between driveability, e.g. power and torque, fuel economy and emissions. An engine equipped with a variable valve actuation system is freed from this constraint, allowing performance to be improved over the engine operating range.

Relationships with other classification places

Valve-gear or valve arrangements: [F01L](#)

Electronic engine control in general: [F02D](#)

References

Limiting references

This place does not cover:

Electrical control of supply of combustible mixtures	F02D 41/00
Modifications of valve gear	F01L 13/00

Informative references

Attention is drawn to the following places, which may be of interest for search:

Electrical control of supply of combustible mixtures	F02D 41/00
Modifications of valve gear	F01L 13/00

Glossary of terms

In this place, the following terms or expressions are used with the meaning indicated:

Miller-Atkinson cycle	Combustion cycle characterised by extending the stroke and raising the expansion and compression ratio. Premature detonation is overcome by using valve timing variations to make the effective compression and expansion strokes asymmetrical.
-----------------------	---

Synonyms and Keywords

In patent documents, the following abbreviations are often used:

VVT	Variable valve timing
SOHC	Single overhead camshaft
DOHC	Double overhead camshaft
EGR	Exhaust gas recirculation

F02D 15/00

Varying compression ratio (modifying valve gear [F01L](#))

Definition statement

This place covers:

Varying compression ratio to adjust internal combustion engine cylinder compression ratios. For automotive use this needs to be done dynamically in response to the load and driving demands. Higher loads require lower ratios to be more efficient and vice versa. Variable compression engines allow for the volume above the piston at TDC to be changed.

Relationships with other classification places

Other engines, [F02B 75/00](#); varying inlet or exhaust valve operating characteristics, [F02D 13/00](#); electrical control of supply of combustible mixtures, [F02D 41/00](#).

References

Limiting references

This place does not cover:

Modifying valve gear	F01L 13/00
Means for creating variable distances between pistons at top dead-centre positions and cylinder heads.	F02B 75/04

Informative references

Attention is drawn to the following places, which may be of interest for search:

Engines with variable distances between pistons at top dead-centre positions and cylinder heads.	F02B 75/04
--	----------------------------

Glossary of terms

In this place, the following terms or expressions are used with the meaning indicated:

TDC	Top Dead Centre
-----	-----------------

F02D 17/00

Controlling engines by cutting out individual cylinders; Rendering engines inoperative or idling (controlling or rendering inoperative by varying inlet or exhaust valve operating characteristics [F02D 13/00](#))

Definition statement

This place covers:

Controlling engines by cutting out individual cylinders; Rendering engines inoperative or idling. Cylinder deactivation is used to reduce the fuel consumption and emissions of an internal combustion engine during light-load operation. In typical light-load driving the driver uses only around 30 percent of an engine's maximum power. In these conditions the throttle valve is nearly closed and the engine needs to work to draw air. This causes an inefficiency known as pumping loss. Some large capacity engines need to be throttled so much at light load that the cylinder pressure at top dead centre is approximately half that of a small 4-cylinder engine. Low cylinder pressure means low fuel efficiency. The use of cylinder deactivation at light load means there are fewer cylinders drawing air from the

intake manifold, which works to increase its air pressure. Operation without variable displacement is wasteful because fuel is continuously pumped into each cylinder and combusted even though maximum performance is not required.

Relationships with other classification places

Control systems for hybrid vehicles: [B60W 20/00](#);

Controlling engines driving vehicles: [F02D 29/00](#);

Starting engines: [F02N 11/00](#).

References

Limiting references

This place does not cover:

Cutting out cylinders by varying inlet or outlet valve operating characteristics	F02D 13/06
Rendering engine inoperative or idling by varying inlet or outlet valve operating characteristics	F02D 13/08

Informative references

Attention is drawn to the following places, which may be of interest for search:

Varying inlet or exhaust valve operating characteristics	F02D 13/00
Engines with air storage chambers	F02B 21/00
Piston pumps for charging	F02B 33/00

F02D 19/00

Controlling engines characterised by their use of non-liquid fuels, pluralities of fuels, or non-fuel substances added to the combustible mixtures (the non-fuel substances being gaseous [F02D 21/00](#))

Definition statement

This place covers:

Mechanical and control aspects of engines using gaseous fuels, solid fuels or a combination of gaseous and non gaseous fuels. The latter simultaneously or non simultaneously used. Important aspects of the group are: configuration and control of the fuel supply system, special operating modes depending on the type of fuel and measuring and estimating of the fuel and engine parameters.

Relationships with other classification places

Control of engines using non-liquid fuels, [F02D 41/0025](#)

References

Limiting references

This place does not cover:

Controlling engines being supplied with gaseous non-fuel substances	F02D 21/00
Electronic control of engines using non-liquid fuels	F02D 41/0025

Informative references

Attention is drawn to the following places, which may be of interest for search:

Engines characterised by operating on gaseous fuels	F02B 43/00
Apparatus for supplying engines with gaseous fuels	F02M 21/00

Glossary of terms

In this place, the following terms or expressions are used with the meaning indicated:

Non-fuel gas	Oxygen, exhaust gas etc.
--------------	--------------------------

F02D 21/00**Controlling engines characterised by their being supplied with non-airborne oxygen or other non-fuel gas****Definition statement**

This place covers:

Control systems in which oxygen or secondary air and/or exhaust or other non-fuel gases are being fed to the engine in order to increase the engine output power and/or to clean the exhaust gases.

Relationships with other classification places

Engine-pertinent apparatus for adding non-fuel substances or small quantities of secondary fuel to combustion-air, main fuel, or fuel-air mixture, [F02M 25/00](#);

Electrical control of supply of combustible mixture or its constituents, [F02D 41/00](#); Methods of operating engines involving adding non-fuel substances or anti-knock agents to combustion air, fuel or fuel-air mixtures of engines, [F02B 47/00](#).

References**Limiting references**

This place does not cover:

Methods and electrical aspects of controlling exhaust gas recirculation	F02D 41/0047
---	------------------------------

Informative references

Attention is drawn to the following places, which may be of interest for search:

Chemical or biological purification of waste gases, e.g. engine exhaust gases, smoke, fumes, fuel gases, aerosols.	B01D 53/00
--	----------------------------

Glossary of terms

In this place, the following terms or expressions are used with the meaning indicated:

Non-airborne oxygen	Oxygen not from the air
Secondary air	Air not entering main intake

F02D 23/00

Controlling engines characterised by their being supercharged

Definition statement

This place covers:

Control systems for controlling the power output or rotational speed of the engine by other means than the throttle valve. In case of a supercharged engine it is possible for the power output or rotational speed to be additionally influenced for example by way of a controllable valve which is arranged parallel to the compressor in the induction track of the engine.

Relationships with other classification places

Engines characterised by provision of pumps for charging or scavenging, [F02B 33/00](#); engines characterised by provision of pumps driven at least for part of the time by exhaust, [F02B 37/00](#).

References

Limiting references

This place does not cover:

Electrical control of supply of combustible mixture or its constituents	F02D 41/00
---	----------------------------

Informative references

Attention is drawn to the following places, which may be of interest for search:

Component parts, details, or accessories relating to, driven charging or scavenging pumps, not provided for in groups F02B 33/00 - F02B 37/00	F02B 39/00
---	----------------------------

Glossary of terms

In this place, the following terms or expressions are used with the meaning indicated:

Supercharged	Turbocharged
--------------	--------------

Synonyms and Keywords

In patent documents, the following words/expressions are often used as synonyms:

- "supercharged" and "turbocharged "

F02D 25/00

Controlling two or more co-operating engines

Definition statement

This place covers:

Methods and devices for controlling engine arrangements comprising at least a first and a second internal combustion engine, wherein each engine comprises a crankshaft and at least one cylinder with a piston connected to said crankshaft, a controllable clutch arranged between the crankshafts, an engine control unit (ECU) for controlling the first and second engine and sensors for monitoring at least one operating parameter for the said engines connected to the engine control unit.

Relationships with other classification places

Propulsion units for ships, [B63H 21/00](#); propulsion units for trains, [B61C 11/00](#); power plants, [F01K 7/00](#); transmitting power from propulsion power plant to

propulsive elements, [B63H 23/00](#).

References

Limiting references

This place does not cover:

Cutting out individual cylinders	F02D 17/00
Controlling engines, such controlling being peculiar to the devices driven thereby	F02D 29/00
Conjoint control of vehicle sub-units of different type or different function	B60W 10/00

Informative references

Attention is drawn to the following places, which may be of interest for search:

Combinations of two or more engines, not otherwise provided for	F02B 73/00
---	----------------------------

Glossary of terms

In this place, the following terms or expressions are used with the meaning indicated:

Conjoint control	Control of 2 or more cooperating engines
Master and slave engine	Primary and secondary engine

F02D 27/00

Controlling engines characterised by their being reversible

Definition statement

This place covers:

Engines that can be operated in two directions, i.e. of which the crankshaft can turn in two directions during running of the engine. These engines require amongst others displaceable camshafts. The reversing requires a control program during which several parameters of the engine, e.g. speed, throttle- position, fuel supply should be controlled.

Relationships with other classification places

Ship propulsion units, [B63H 21/00](#).

References

Limiting references

This place does not cover:

Toothed gearings for reversing rotary motion	F16H 3/00
--	---------------------------

Informative references

Attention is drawn to the following places, which may be of interest for search:

Use of propulsion power plants or units on vessels	B63H 21/00
Modifications of valve-gear to facilitate reversing	F01L 13/00
Other engines	F02B 75/00

F02D 28/00

Programme-control of engines (programme-control specific to a type or purpose covered by one of the groups of this subclass except groups [F02D 29/00](#), [F02D 39/00](#), or by one group of another subclass, e.g. [F01L](#), see that group; programme-control in general [G05B 19/00](#))

Definition statement

This place covers:

Program-control of engines. Although operator control is suitable for automobile engines, there are many systems, such as standby emergency electric power systems, where this type of control is impractical and expensive. For these applications, automatic program control systems have been devised which perform necessary engine control functions without operator attendance. Programme control is also used in remote starting systems for automobile engines for example heating up the passenger cabin.

Relationships with other classification places

Electrical control of supply of combustible mixture or its constituents, [F02D 41/00](#); conjoint electrical control of two or more functions, [F02D 43/00](#); electrical control not provided for in groups [F02D 41/00](#)-[F02D 43/00](#).

References**Limiting references**

This place does not cover:

Controlling engines, dependent on conditions exterior or interior to engines	F02D 35/00
Program control in general	G05B 19/00

Informative references

Attention is drawn to the following places, which may be of interest for search:

Controlling the engine output power by varying inlet or exhaust valve operating characteristics, e.g. timing	F02D 13/00
Automatic vehicle control systems	B62D
Starting of engines by means of electric motors	F02N 11/00
Traffic control systems for road vehicles	G08G 1/00

F02D 29/00

Controlling engines, such controlling being peculiar to the devices driven thereby, the devices being other than parts or accessories essential to engine operation, e.g. controlling of engines by signals external thereto

Definition statement

This place covers:

Control systems characterised by the device driven by the engine. This device can be for example a vehicle, a pump or an electric generator.

Relationships with other classification places

Electrical control of internal combustion engines, [F02D 39/00](#)- [F02D 45/00](#); positive displacement machines for liquids, [F04B/00](#); controlling electric generators, [H02P](#).

References

Limiting references

This place does not cover:

Arrangement or mounting of plural diverse prime-movers for mutual or common propulsion, e.g. hybrid propulsion systems comprising electric motors and internal combustion engines	B60K 6/00
Conjoint control of vehicle sub-units of different type or different function	B60W 10/00
Control systems specially adapted for hybrid vehicles	B60W 20/00

Informative references

Attention is drawn to the following places, which may be of interest for search:

Propellers	B64C 11/00
Control e.g. of pump delivery, or of pump pressure, or safety measures for, machines, pumps, or pumping installations, not otherwise provided for.	F04B 49/00
Arrangements for controlling electric generators for the purpose of obtaining a desired output	H02P 9/00

F02D 31/00

Use of speed-sensing governors to control combustion engines, not otherwise provided for

Definition statement

This place covers:

Mechanical governors, e.g. Watt type

F02D 31/001**{Electric control of rotation speed}****Definition statement***This place covers:*

Electrical control of engine rotation speed, e.g. by including a speed feedback loop

F02D 31/002**{controlling air supply}****Definition statement***This place covers:*

Controlling the air supply, mainly by changing the throttle position, in order to control the engine speed

References**Limiting references***This place does not cover:*

Vehicle cruise control	B60K 31/00
------------------------	----------------------------

F02D 31/003**{for idle speed control}****Definition statement***This place covers:*

Throttle opening control after engine speed in idle mode; also setting of idle speed

F02D 31/004**{by controlling a throttle stop}****Definition statement***This place covers:*

Control whereby an electric actuator urges the throttle, or the throttle lever from its closed position

F02D 31/005**{by controlling a throttle by-pass}****Definition statement***This place covers:*

Control whereby in a bypass the air flow must be controlled after engine speed and throttle position

F02D 31/006**{for maximum speed control}****Definition statement***This place covers:*

Control whereby throttle is used to limit engine speed.

F02D 31/007**{controlling fuel supply}****Definition statement***This place covers:*

Rotation speed control by fuel amount, e.g. Diesel governors

F02D 31/008**{for idle speed control}****Definition statement***This place covers:*

Feedback control of idling speed using fuel supply

F02D 33/00**Controlling delivery of fuel or combustion-air, not otherwise provided for
{(using exhaust gas sensors [F02D 35/0023](#), [F02D 35/0046](#))}****Definition statement***This place covers:*

Controlling the feeding of liquid fuel from storage containers to carburettors or fuel-injection apparatus or the controlling the delivery of combustion air.

Relationships with other classification placesElectrical control of supply of combustible mixtures, [F02D 41/00](#); apparatus or systems for feeding liquid fuel from storage containers to carburettors or fuel-injection apparatus, [F02M 37/00](#).**References****Limiting references***This place does not cover:*

Controlling air supply using exhaust gas sensors	F02D 35/0023
Controlling fuel supply using exhaust gas sensors	F02D 35/0046

Informative references*Attention is drawn to the following places, which may be of interest for search:*

Control of electrical fuel pumps	F02D 41/3082
----------------------------------	------------------------------

Control of fuel flow to a common rail	F02D 41/3845
---------------------------------------	------------------------------

Glossary of terms

In this place, the following terms or expressions are used with the meaning indicated:

Storage containers	Fuel tanks
--------------------	------------

Synonyms and Keywords

In patent documents, the following words/expressions are often used as synonyms:

- "common rail" and "fuel rail"

F02D 35/00

Controlling engines, dependent on conditions exterior or interior to engines, not otherwise provided for

Definition statement

This place covers:

Controlling engines using information, e.g. sensor signals, about conditions exterior or interior to engines

F02D 35/0007

{using electrical feedback ([F02D 35/0015](#) takes precedence)}

Definition statement

This place covers:

Position feedback on an electrical actuator.

F02D 35/0015

{using exhaust gas sensors ([F02D 41/14](#) takes precedence)}

Relationships with other classification places

This group contains engine controls using an exhaust gas sensor. Engine control using a gas sensor for sensing composition of combustion gases is classified in [F02D 41/1438](#).

F02D 35/0023

{Controlling air supply}

Definition statement

This place covers:

Control of air supply as a function of an air/fuel sensor signal

F02D 35/0046**{Controlling fuel supply}****Definition statement***This place covers:*

Fuel supply control after an air/fuel sensor.

F02D 35/0053**{by means of a carburettor}****Definition statement***This place covers:*

Carburettor control after an air/fuel sensor

F02D 35/0061**{Controlling the emulsifying air only ([F02D 35/0076](#), [F02D 35/0084](#) take precedence)}****Definition statement***This place covers:*

Controlling the emulsifying air only whereby most of the carburettors have a sub carburettor and it is the air/fuel mixture made in this sub carburettor (easier to control) which is drawn into the main venturi of the carburettor.

F02D 35/0069**{Controlling the fuel flow only ([F02D 35/0076](#), [F02D 35/0084](#) take precedence)}****Definition statement***This place covers:*

Fuel flow control via a valve in series in the fuel alimentation of the said sub carburettor or via a valve controlling the supply of air above the constant level fuel reservoir. If this valve is closed, less fuel can be sucked into the engine.

F02D 35/0076**{using variable venturi carburettors}****Definition statement***This place covers:*

Fuel flow using variable venturi carburettors, i.e. a special type of horizontal carburettor still used in the 80s.

F02D 35/02**on interior conditions****Definition statement**

This place covers:

Control according to parameters interior to the combustion chamber that may be used to influence this combustion

References**Limiting references**

This place does not cover:

Knock control using ignition timing	F02P 5/152
Ignition timing control based on combustion pressure	F02P 5/153

F02D 35/021

{using an ionic current sensor}

References**Limiting references**

This place does not cover:

Ionic sensor for testing of ignition	F02P 17/12
--------------------------------------	----------------------------

Special rules of classification

If the sensor is located in the combustion gases then classify in [F02D 35/021](#) and [F02D 41/1444](#) .

F02D 35/022

{using an optical sensor, e.g. in-cylinder light probe}

References**Limiting references**

This place does not cover:

Optical sensors in the exhaust system	F02D 41/1451
---------------------------------------	------------------------------

F02D 37/02

one of the functions being ignition (ignition control per se [F02P](#){, automatically advancing or retarding ignition combined with electronic control of other engine functions, e.g. fuel injection [F02P 5/045](#)})

Definition statement

This place covers:

Conjoint control using ignition timing and at least another parameter, e.g. air amount or fuel injection.

F02D 39/00

Other non-electrical control

Definition statement

This place covers:

Non-electrical control of four- or two-stroke engines; of engines adding the fuel substantially at the end or before the compression stroke; of free piston engines.

Relationships with other classification places

Controlling engines, dependent on conditions exterior or interior to engines, not otherwise provided for [F02D 35/00](#)

References

Limiting references

This place does not cover:

Controlling engines, such controlling being peculiar to the devices driven thereby	F02D 29/00
Two stroke engines	F02B 25/00
Rotary engines	F02B 53/00
Free piston engines	F02B 71/00

Informative references

Attention is drawn to the following places, which may be of interest for search:

Other types of engines, e.g. double acting engines	F02B 75/00
--	----------------------------

Glossary of terms

In this place, the following terms or expressions are used with the meaning indicated:

Free piston engines	Engines without rotary main shaft
---------------------	-----------------------------------

Synonyms and Keywords

In patent documents, the following words/expressions are often used as synonyms:

- "non-electrical control" and "mechanical control"

F02D 41/00

Electrical control of supply of combustible mixture or its constituents ([F02D 43/00](#) takes precedence)

Definition statement

This place covers:

Electrical or electronical control of combustion engines

Relationships with other classification places

Non-electrical aspects of electrically controlled devices are covered by

groups [F02D 1/00](#) - [F02D 39/00](#) or by subclass [F02M](#);

- both electrical and non-electrical aspects of electrically controlled devices

are covered by groups [F02D 1/00](#) - [F02D 39/00](#) or by subclass [F02M](#)

References

Limiting references

This place does not cover:

Control of engine starters	F02N 11/08
Electrical control of engine ignition timing	F02P 5/145

Informative references

Attention is drawn to the following places, which may be of interest for search:

Conjoint control of vehicle sub-units including control of combustion engine	B60W 10/06
Detection of engine knocking	G01L 23/22
Detection of engine misfires	G01M 15/11
Gas sensors, e.g. oxygen sensors	G01N 27/00

Special rules of classification

Main group [F02D 41/00](#) is not used. Use [F02D 41/3005](#) instead.

Glossary of terms

In this place, the following terms or expressions are used with the meaning indicated:

EGR	Exhaust gas recirculation
-----	---------------------------

Synonyms and Keywords

In patent documents, the following abbreviations are often used:

VVT	Variable valve timing
-----	-----------------------

F02D 41/0002

{Controlling intake air}

Definition statement

This place covers:

Control of intake air amount, e.g. by using:

Throttle

Swirl throttle (Dralldrossel) on the side of intake pipe or in a second special intake pipe. It makes air flow to be twisted at low speeds to promote homogenization between air and fuel mist.

Variable valve timing and/or lift

References

Informative references

Attention is drawn to the following places, which may be of interest for search:

VVT	F02D 13/02
-----	----------------------------

F02D 41/0007

{for control of turbo-charged or super-charged engines (control of the pumps per se [F02B 37/12](#))}

References

Informative references

Attention is drawn to the following places, which may be of interest for search:

Mechanical control of turbocharged injected engine	F02D 23/02
Control of turbochargers and superchargers per se	F02B 37/12

F02D 41/0025

{Controlling engines characterised by use of non-liquid fuels, pluralities of fuels, or non-fuel substances added to the combustible mixtures}

Definition statement

This place covers:

Controlling engines running with:

- non-liquid fuels- multiple fuels, e.g. different octane rates, alcohol + gasoline- additives added to the fuel/air (for catalyst, for enhancing burning (pure O₂, N₂O), etc)- alcohol, methanol and problems linked to the fuel quality/property

References

Limiting references

This place does not cover:

Gas engines	F02D 41/0027
Control using fuel type or fuel quality sensor	F02D 2200/0611
Control using fuel type or fuel quality estimation	F02D 2200/0611

Informative references

Attention is drawn to the following places, which may be of interest for search:

More mechanical aspects of control	F02D 19/00
Corresponding arrangements	F02M 25/00

F02D 41/003**{Adding fuel vapours, e.g. drawn from engine fuel reservoir}****Definition statement***This place covers:*

Control of the supply of fuel vapours which are normally drawn from a canister which adsorbs fuel vapours generated in the fuel tank

References**Informative references***Attention is drawn to the following places, which may be of interest for search:*

System arrangements for fuel vapour purging	F02M 25/08
Fuel vapour system diagnosis	F02M 25/0809

F02D 41/0032**{Controlling the purging of the canister as a function of the engine operating conditions}****Definition statement***This place covers:*

Engine conditions are taken into account and purging is controlled

F02D 41/0035**{to achieve a special effect, e.g. to warm up the catalyst}****Definition statement***This place covers:*

Purging is used for a particular effect on the engine, e.g. to warm-up catalyst

F02D 41/0037**{for diagnosing the engine (diagnosis of purge control systems [F02M 25/0809](#))}****Definition statement***This place covers:*

Control of purging to achieve conditions which are suitable for engine Diagnosis. - If the expected effect due to purging does not occur, failure is determined- Switch off of purging to prevent influence on diagnosis

References**Limiting references***This place does not cover:*

Diagnosis of purge control systems	F02M 25/0809
------------------------------------	------------------------------

F02D 41/004

{Control of the valve or purge actuator, e.g. duty cycle, closed loop control of position}

Definition statement

This place covers:

Details specific to the control of the purge valve itself

F02D 41/0042

{Controlling the combustible mixture as a function of the canister purging, e.g. control of injected fuel to compensate for deviation of air fuel ratio when purging}

Definition statement

This place covers:

Control of the engine mixture is adapted to purging taking place

F02D 41/0045

{Estimating, calculating or determining the purging rate, amount, flow or concentration}

Definition statement

This place covers:

Details specific to the estimation, calculation or any kind of determination of the purge quantity

F02D 41/0047

{Controlling exhaust gas recirculation [EGR] (temperature control with cooler in recirculation circuit [F02M 26/33](#))}

Definition statement

This place covers:

Electrical control of exhaust gas recirculation (EGR)

References**Informative references**

Attention is drawn to the following places, which may be of interest for search:

Mechanical control of EGR	F02D 21/08
Constructional aspects of EGR circuits	F02M 26/00
Temperature control using EGR cooler	F02M 26/33
Diagnosis of EGR	F02M 26/49

F02D 41/0052

{Feedback control of engine parameters, e.g. for control of air/fuel ratio or intake air amount}

Definition statement

This place covers:

Feedback control using EGR for all parameter not directly related to EGR. This might include:

intake amount amount

intake manifold pressure

air/fuel ratio

combustion timing

engine roughness

References

Limiting references

This place does not cover:

Internal EGR rate or amount feedback	F02D 41/0062
External EGR rate or amount feedback	F02D 41/0072

Special rules of classification

The feedback parameter should be classified in the corresponding groups as well

F02D 41/0055

{Special engine operating conditions, e.g. for regeneration of exhaust gas treatment apparatus}

Definition statement

This place covers:

Special control of EGR for non-ordinary operating conditions, e.g.:

- engine diagnosis- during fuel cut- Exhaust catalyst regeneration

F02D 41/0057

{Specific combustion modes (combustion modes per se [F02D 41/3017](#))}

Definition statement

This place covers:

EGR control according to or during engine operation with specific combustion modes, e.g. special engines with two EGR modes on both sides of the peak of smoke which appears when the EGR rate is increased in a diesel engine or HCCI without anything specific to EGR control

Relationships with other classification places

Feedback control of EGR to control combustion timing e.g. in HCCI mode; [F02D 41/0052](#)

References

Informative references

Attention is drawn to the following places, which may be of interest for search:

Combustion modes	F02D 41/3017
------------------	------------------------------

F02D 41/006

{using internal EGR (control of valve overlap for internal EGR [F02D 13/0261](#); arrangements for internal EGR [F02M 26/01](#))}

Definition statement

This place covers:

Exhaust gases are redirected into the combustion chamber or kept as residual gases during positive or negative valve overlap

References

Informative references

Attention is drawn to the following places, which may be of interest for search:

Valve overlap control	F02D 13/0261
Arrangements for internal EGR	F02M 26/01

F02D 41/0062

{Estimating, calculating or determining the internal EGR rate, amount or flow}

Definition statement

This place covers:

Determination of the EGR rate or residual gas amount remaining in the cylinder when internal EGR is used

Special rules of classification

Only as additional information if parameter is only mentioned without details on how to determine it

F02D 41/0065

{Specific aspects of external EGR control (constructional details of EGR system [F02M 26/00](#))}

Definition statement

This place covers:

something specific to external EGR, e.g. considering transport delays or when using low pressure and high pressure EGR circuits

F02D 41/0072

{Estimating, calculating or determining the EGR rate, amount or flow (sensors in EGR systems [F02M 26/45](#))}

Definition statement

This place covers:

Determination of the EGR rate in external EGR circuits

Special rules of classification

Only as additional information if parameter is only mentioned without details on how to determine it

F02D 41/0077

{Control of the EGR valve or actuator, e.g. duty cycle, closed loop control of position (EGR valve position sensor [F02M 26/48](#))}

References**Informative references**

Attention is drawn to the following places, which may be of interest for search:

EGR valve position sensors	F02M 26/48
----------------------------	----------------------------

F02D 41/008

{Controlling each cylinder individually}

Definition statement

This place covers:

Operation of individual engine cylinders with different operating parameters, e.g. different fuel amounts or air amounts

References**Informative references**

Attention is drawn to the following places, which may be of interest for search:

Cylinder individual control of ignition timing	F02P 5/1512
--	-----------------------------

Special rules of classification

Multiple classification for the corresponding actuator(s) applies

F02D 41/0082

{per groups or banks ([F02D 41/0087](#) takes precedence)}

Definition statement

This place covers:

Operation of cylinder groups with different operating parameters, e.g. first cylinder group operating lean and second cylinder group operating rich to achieve heating or regeneration of catalysts

Special rules of classification

This group is not used for deactivation of cylinder banks which should be classified in [F02D 41/0087](#) only

F02D 41/0085

{Balancing of cylinder outputs, e.g. speed, torque or air-fuel ratio}

Definition statement

This place covers:

Control to equalise engine operating parameter for all cylinders

Relationships with other classification places

There might be some overlap with [F02D 41/1498](#), however [F02D 41/1498](#) covers at least measuring/detecting roughness per se, control according to roughness when all cylinders are controlled in the same way (e.g. idling/lean rough limit). If there is roughness detection and individual control then both groups should be used. Some overlap with engine roughness

F02D 41/0087

{Selective cylinder activation, i.e. partial cylinder operation (deceleration cut-off [F02D 41/123](#))}

Definition statement

This place covers:

Selective activation or deactivation of cylinders: every cylinder is fed with an optimal fuel quantity for an optimal combustion or with no fuel at all. The engine power also being controlled by the number of fed cylinders and not by the throttle and the air/fuel per cylinder.

References

Limiting references

This place does not cover:

Complete fuel-cut in all cylinders during deceleration	F02D 41/123
--	-----------------------------

F02D 41/009

{using means for generating position or synchronisation signals}

Definition statement

This place covers:

Detection of engine crank angle position and generation of synchronisation signals, i.e. information about which cylinder is in which cycle (intake, compression, expansion or exhaust cycle).

References

Informative references

Attention is drawn to the following places, which may be of interest for search:

Position for ignition	F02P 7/06
-----------------------	---------------------------

F02D 41/0097**{using means for generating speed signals}****Definition statement***This place covers:*

Detection and measurement of engine speed.

References**Informative references***Attention is drawn to the following places, which may be of interest for search:*

Rotation speed measurement in general	G01P 3/44
---------------------------------------	---------------------------

F02D 41/02**Circuit arrangements for generating control signals****Special rules of classification**

This group should not be used.

F02D 41/0205**{using an auxiliary engine speed control (engine speed control per se [F02D 31/00](#))}****Definition statement***This place covers:*

Generator, pump or PTO (e.g. agricultural Power Take Off) engines with an externally needed regulated speed control.

References**Limiting references***This place does not cover:*

Vehicle cruise speed control	B60K 31/00
------------------------------	----------------------------

F02D 41/021**{Introducing corrections for particular conditions exterior to the engine (conjoint control of vehicle sub-units for propelling the vehicle [B60W 30/18](#))}****Definition statement***This place covers:*

Control according to particular conditions exterior to the engine, e.g.

- positional information from navigation systems
- road conditions
- engine control in relation with other vehicle sub-systems

Special rules of classification

The conditions exterior to the engine should also be classified in [F02D 2200/70](#).

F02D 41/0215

{in relation with elements of the transmission}

Definition statement

This place covers:

Control of the engine in relation with gearbox and/or clutch

References

Informative references

Attention is drawn to the following places, which may be of interest for search:

More general aspects of driveline control, conjoint control of driveline elements	B60W 30/18
---	----------------------------

F02D 41/023

{in relation with the gear ratio shifting (conjoint control for improving gear change [B60W 30/19](#))}

Definition statement

This place covers:

Special control during the gear shift. Usually torque or speed control to target values

References

Informative references

Attention is drawn to the following places, which may be of interest for search:

Conjoint control to improve gear change	B60W 30/19
---	----------------------------

F02D 41/0235

{in relation with the state of the exhaust gas treating apparatus (control of exhaust gas treating apparatus per se [F01N](#))}

Definition statement

This place covers:

Control of engine in order to achieve specific effect on exhaust gas treatment device, e.g. regeneration or warming-up

Relationships with other classification places

Borderline between [F02D 41/0235](#) and [F01N](#) is defined based on where the intervention to achieve heating or regeneration takes place:

- [F02D 41/0235](#) if the engine control is affected
- [F01N](#) if the control takes place in the exhaust, e.g. by injection into the exhaust pipe or electrical heating for catalysts

F02D 41/024**{to increase temperature of the exhaust gas treating apparatus}****Definition statement***This place covers:*

Engine control to increase the temperature of an exhaust gas catalyst or filter also given for regeneration, when method for temperature increase is important

F02D 41/0245**{by increasing temperature of the exhaust gas leaving the engine}****Definition statement***This place covers:*

Methods for raising catalyst temperature wherein additional heat is generated by combustion inside cylinder, e.g. by early post injection and delaying (main) injection timing.

F02D 41/025**{by changing the composition of the exhaust gas, e.g. for exothermic reaction on exhaust gas treating apparatus}****Definition statement***This place covers:*

Methods for raising catalyst temperature wherein additional heat is generated in exhaust pipe or on catalyst, e.g. by late post injection with surplus of oxygen from same/other cylinder, or by driving cylinders with different air/fuel ratios so that exhaust gases from these cylinders mix in exhaust pipe.

F02D 41/027**{to purge or regenerate the exhaust gas treating apparatus}****Definition statement***This place covers:*

Engine control without special control according to the type of catalyst

F02D 41/0275**{the exhaust gas treating apparatus being a NO_x trap or adsorbent}****Special rules of classification**

Parameters characterising the state of the exhaust gas treating apparatus should be classified in [F02D 2200/08](#) as well. [F02D 2200/0806-F02D 2200/0811](#) are of particular importance for NO_x traps.

F02D 41/028**{Desulfurisation of NOx traps or adsorbent}****Special rules of classification**

Parameters characterising the state of the exhaust gas treating apparatus should be classified in [F02D 2200/08](#) as well. [F02D 2200/0818](#) is of particular importance for the desulfurisation of NOx traps.

F02D 41/029**{the exhaust gas treating apparatus being a particulate filter}****References****Informative references**

Attention is drawn to the following places, which may be of interest for search:

Regenerating particle filter with means in exhaust;	F01N 3/023
---	----------------------------

Special rules of classification

Parameters characterising the state of the exhaust gas treating apparatus should be classified in [F02D 2200/08](#) as well. [F02D 2200/0812](#) is of particular importance for the regeneration of particle filters.

F02D 41/0295**{Control according to the amount of oxygen that is stored on the exhaust gas treating apparatus}****Definition statement**

This place covers:

Control of engine air/fuel ratio so that amount of oxygen that is stored on (three-way)-catalyst with oxygen storage capacity meets target value.

Special rules of classification

Parameters characterising the state of the exhaust gas treating apparatus should be classified in [F02D 2200/08](#) as well. [F02D 2200/0814](#) and [F02D 2200/0816](#) are of particular importance for this group.

F02D 41/042**{for stopping the engine}****Definition statement**

This place covers:

Control for stopping the engine or during the engine stopping period

References

Informative references

Attention is drawn to the following places, which may be of interest for search:

Stopping of diesel engines	F02D 17/04
----------------------------	----------------------------

F02D 41/047

{Taking into account fuel evaporation or wall wetting; (special correction after fuel cut-off [F02D 41/126](#))}

Definition statement

This place covers:

Control combining partial pressures of vapour fuel, fresh air, recycled exhaust gas, less deposited fuel to calculate real air/fuel ratio taken in each cylinder

Control using models to determine fuel film on intake and cylinder walls

F02D 41/06

for engine starting or warming up {([F02D 41/0255](#) takes precedence)}

Definition statement

This place covers:

Corrections during engine start or warm-up.

F02D 41/061

{the corrections being time dependent}

Definition statement

This place covers:

Corrections during engine start linked to a delay or timer.

F02D 41/062

{for starting ([F02D 41/061](#) takes precedence)}

Definition statement

This place covers:

Corrections during engine start.

F02D 41/064

{at cold start ([F02D 41/067](#) takes precedence)}

Definition statement

This place covers:

Engine control during engine start when engine is cold, e.g. increase of fuel injection amount to compensate increased fuel demand.

F02D 41/065**{at hot start or restart ([F02D 41/067](#) takes precedence)}****Definition statement***This place covers:*

Engine start when engine is warm or immediate restart, e.g. after stall or during engine start/stop control

F02D 41/067**{with control of the choke (non electronic control of choke see [F02M 1/10](#))}****Definition statement***This place covers:*

Purely electrical chokes as well as mechanical automatic chokes where the bimetallic spiral or wax actuator is electrically heated when the engine has started.

F02D 41/068**{for warming-up}****Definition statement***This place covers:*

Warming-up measures, e.g. fast idle to accelerate warming-up

F02D 41/08**for idling ([F02D 41/06](#), [F02D 41/16](#) take precedence)****Definition statement***This place covers:*

Engine control during idling

References**Informative references**

Attention is drawn to the following places, which may be of interest for search:

Feedback control of idling speed	F02D 31/003 , F02D 31/008
----------------------------------	--

F02D 41/083**{taking into account engine load variation, e.g. air-conditionning}****Definition statement***This place covers:*

Engine control during idling considering external loads, e.g.

- air condition
- generators

- power steering

F02D 41/10

for acceleration

Definition statement

This place covers:

Engine control during acceleration, e.g. increase of fuel injection amount to meet increased demand.

F02D 41/102

{Switching from sequential injection to simultaneous injection}

Definition statement

This place covers:

Increase of the number of injectors in intake low pressure injection to increase fuel flow

F02D 41/105

{using asynchronous injection}

Definition statement

This place covers:

Control with extra fuel pulse at start of acceleration in addition to ordinary fuel pulses which are sequentially injected at regular intervals

F02D 41/123

{the fuel injection being cut-off}

Definition statement

This place covers:

The fuel being cut off in all cylinders during deceleration as long as there is no serious reason to restart.

References

Informative references

Attention is drawn to the following places, which may be of interest for search:

Selective activation/deactivation of some, but not all cylinders	F02D 41/0087
--	------------------------------

F02D 41/126

{transitional corrections at the end of the cut-off period}

Definition statement

This place covers:

When the engine is decelerating it is necessary to restart the engine before idle speed is reached to avoid stalling if injection is restarted too late. Transitional measures may also be taken before. Special control to bring back catalyst to normal working range

F02D 41/1401

{characterised by the control or regulation method ([F02D 41/1473](#), [F02D 41/1477](#) take precedence)}

Definition statement

This place covers:

Documents giving details on the feedback loop should be put in this group and groups when it is not a PID or some basic controller, then prefer to classify in [F02D 41/1473](#) and [F02D 41/1477](#)

References

Informative references

Attention is drawn to the following places, which may be of interest for search:

Control in general	G05B , G05G
--------------------	---

Special rules of classification

Classify as well according to what is controlled or what is measured., e.g. [F02D 41/1438](#), [F02D 41/16](#)

F02D 41/1402

{Adaptive control}

Definition statement

This place covers:

The parameters/coefficients of the controller are set/tuned on-line according to the output of the system (there must be a feedback). Also called Self-Tuning regulator.

Relationships with other classification places

Not to be confused with "learning" where some values are stored to be re-used. This should be classified in [F02D 41/2429](#). A controller having different coefficients stored in a table and where the coefficients are chosen according to operating conditions should be classified in [F02D 2041/1422](#).

F02D 41/1408**{Dithering techniques}****References*****Informative references****Attention is drawn to the following places, which may be of interest for search:*

Dithering for learning in air/fuel ratio control	F02D 41/2458
--	------------------------------

F02D 41/1438**{using means for determining characteristics of the combustion gases;
Sensors therefor}****Definition statement***This place covers:*

Control according to a characteristic of the combustion gases.

F02D 41/144**{Sensor in intake manifold}****Definition statement***This place covers:*Use of a gas concentration sensor in the intake manifold, e.g. to measure the O₂/fuel ratio before the mixture enters the combustion chambers in order to avoid the two-revolutions delay.**F02D 41/1441****{Plural sensors}****Definition statement***This place covers:*

Multiple sensor arrangements in the exhaust system, e.g. one sensor before the catalyst converter and one after to check its functioning

Downstream sensor might be used for tuning the air/fuel ratio loop based on the upstream sensor

F02D 41/1443**{with one sensor per cylinder or group of cylinders}****Definition statement***This place covers:*

A sensor is provided for each cylinder group or bank, e.g. in the case of V- or flat engines for example

F02D 41/1444**{characterised by the characteristics of the combustion gases}****References*****Informative references****Attention is drawn to the following places, which may be of interest for search:*

Gas sensors in general	G01N 27/00
------------------------	----------------------------

F02D 41/1451**{the sensor being an optical sensor}****Definition statement***This place covers:*

Use of an optical sensor in the exhaust system, e.g. for smoke measurements by evaluating the color/transparency of the exhaust gases.

References***Limiting references****This place does not cover:*

Optical sensors in combustion chamber	F02D 35/022
---------------------------------------	-----------------------------

F02D 41/1475**{Regulating the air fuel ratio at a value other than stoichiometry}****Definition statement***This place covers:*

Engine control to achieve an air-fuel ratio deviating from the stoichiometric air/fuel ratio, e.g. by:

- shifting the comparator level- having different rising and descending slopes for the integral or the proportional part of the control- using a linear sensor

F02D 41/1476**{Biasing of the sensor}****Definition statement***This place covers:*

Two-states sensors wherein a flow of O₂ ions across the porous sensor is simulated by simply sending electrons

F02D 41/1477

{characterised by the regulation circuit or part of it,(e.g. comparator, PI regulator, output)}

Definition statement

This place covers:

Air/fuel ratio control circuits and its components

F02D 41/1479

{Using a comparator with variable reference}

Definition statement

This place covers:

Air/fuel ratio control with two-state air/fuel ratio sensor wherein the air/fuel ratio sensor signal is compared with a variable reference to have a lambda regulation value different from 1

Adaptation of the comparator value to variation of sensor characteristics, e.g. with temperature or age

F02D 41/148

{Using a plurality of comparators}

Definition statement

This place covers:

Air/fuel ratio control using a plurality of comparators, e.g. by selecting among them according to circumstances, to have a lambda regulation value different from 1.

F02D 41/1481

{Using a delaying circuit}

Definition statement

This place covers:

Control related to the problem caused by the delay between the fuel injection and the sensing of exhaust gas properties due to travel in intake, compression, expansion, exhaust and travel in exhaust. To reduce the generated oscillation in steady some delays are introduced in the regulation loop.

F02D 41/1486

{with correction for particular operating conditions}

Definition statement

This place covers:

Air/fuel ratio control during particular operating conditions, e.g. during transient conditions.

F02D 41/1488**{Inhibiting the regulation}****Definition statement***This place covers:*

Deactivation of air/fuel control based on exhaust sensor measurements, e.g. during transitions

F02D 41/1493**{Details}****Definition statement***This place covers:*

Constructional details of the air/fuel control circuit or its components Air/fuel ratio sensor input circuits

F02D 41/1494**{Control of sensor heater}****Definition statement***This place covers:*

Control of heating of an exhaust gas sensor to its operating temperature

F02D 41/1495**{Detection of abnormalities in the air/fuel ratio feedback system}****Definition statement***This place covers:*

Detection of abnormalities in the air/fuel ratio feedback system, especially air/fuel ratio sensor failure detection, e.g. by checking its temperature, its resistivity, its speed of reaction or its output voltage range.

References**Informative references***Attention is drawn to the following places, which may be of interest for search:*

Sensor diagnosis per se	G01N 27/4175
-------------------------	------------------------------

F02D 41/1497**{With detection of the mechanical response of the engine}****Definition statement***This place covers:*

Control using demanded and measured torque, power etc...

F02D 41/1498

{measuring engine roughness}

Definition statement

This place covers:

Detection of roughness caused by misfires due to insufficient fuel in the cylinder or due to a too late ignition not able to reach the fuel cloud. Misfire is a lack of combustion. Detection of roughness caused by different contributions of individual cylinders

F02D 41/18

by measuring intake air flow (measuring flow in general [G01F](#))

Definition statement

This place covers:

Direct air mass measurement

Three types of sensors:

- air flaps normally classified here, with a plate pushed away by air dynamic pressure, which moves a potentiometer giving a resistance or a voltage proportionnal to air flow,
- vortex (Karmann) flowmeters which give a frequency directly proportionnal to the mass of air flowing in the pipe see [F02D 41/185](#)

hot wires using a wire which resistance varies with temperature, and which is heated by electric current and cooled by the air passing on it: they also give a voltage see [F02D 41/187](#)

Computed air flow after manifold depression or throttle opening may also be here with the keyword "parameter measurement - air model"

Relationships with other classification places

There are two schools of injection control: the density based injection where an intake vacuum was combined with rpm after eventual temperature correction and a air-mass based based on an direct air mass flow measure.

References

Informative references

Attention is drawn to the following places, which may be of interest for search:

Measuring the volume flow or mass flow in general	G01F 1/00
---	---------------------------

F02D 41/20

Output circuits, e.g. for controlling currents in command coils (current control in inductive loads in general [H03K 17/64](#))

Definition statement

This place covers:

Circuits for driving injection valves but also gas exchange valves in engines

F02D 41/2096

{for controlling piezo-electric injectors (drive and control circuit for piezo-electric devices in general [H01L 41/042](#))}

References

Informative references

Attention is drawn to the following places, which may be of interest for search:

Drive and control circuit for piezo-electric devices in general	H01L 41/042
---	-----------------------------

F02D 41/22

Safety or indicating devices for abnormal conditions {(in air/fuel ratio feedback systems [F02D 41/1495](#), in electric control linkage [F02D 11/107](#), in purge control systems [F02M 25/0809](#))}

Definition statement

This place covers:

Devices and methods for diagnosing the engine or specific components, e.g. actuators or sensors

Relationships with other classification places

For the diagnosis, the type of the diagnosed actuator or the diagnosed sensor should be classified as well in the corresponding group, e.g.

[F02D 41/30](#) for fuel injectors and [F02D 41/1444](#) for exhaust sensors others than air/fuel ratio sensors

References

Limiting references

This place does not cover:

This group does not cover diagnosis of:

Electric control linkage, e.g. throttles	F02D 11/107
Air/fuel ratio feedback systems including air/fuel ratio sensor diagnosis	F02D 41/1495
Fuel vapour purge systems	F02M 25/0809
EGR systems	F02M 26/49
Exhaust gas treatment systems, e.g. catalytic converters	F02N 11/00

Informative references

Attention is drawn to the following places, which may be of interest for search:

Testing of engine ignition	F02P 17/12
Detection of engine knocking	G01L 23/22
Testing of engines on test benches	G01M 15/00
Detection of engine misfires	G01M 15/11
Testing electrical properties on transport means	G01R 31/006
Registering data indicating performance e.g. black boxes	G07C 5/00 , G07C 5/08

F02D 41/2409**{Addressing techniques specially adapted therefor}****Definition statement***This place covers:*

Choice of addressing parameters for parameter retrieval using maps, e.g. rpm, throttle opening and intake pressure, for example

F02D 41/2412**{One-parameter addressing technique}****Definition statement***This place covers:*

Maps with only one input parameter

F02D 41/2416**{Interpolation techniques}****Definition statement***This place covers:*

Use of interpolation for operating points which are grid points of the maps

F02D 41/2419**{Non-linear variation along at least one coordinate}****Definition statement***This place covers:*

Choice of a logarithmic or an inverted value for a parameter to save memory space

F02D 41/2422**{Selective use of one or more tables}****Definition statement***This place covers:*

Choice of different tables according to certain criteria, e.g. fuel type, to combustion modes

F02D 41/2429**{Methods of calibrating or learning}****Definition statement***This place covers:*

Learning of engine, sensor or actuator characteristics, e.g. by learning an additive or multiplicative correction value to displace a complete table or a plurality of points of a complete table depending on the results of the learning.

Learning to consider dispersions between actuators or sensors.

Learning of control values to considers changes of engine, sensor or actuator characteristics due to aging

F02D 41/2487

{Methods for rewriting}

Definition statement

This place covers:

Rewriting part of the controller memory with new data, e.g. during engine inspections, and associated methods

F02D 41/249

{Methods for preventing the loss of data}

Definition statement

This place covers:

Use of (semi-)permanent memories or using permanent batteries to feed normal memories

F02D 41/266

{the computer being backed-up or assisted by another circuit, e.g. analogue}

Definition statement

This place covers:

Analog or digital circuits in addition to the main control unit, e.g.

- a second control unit, e.g. cylinder control units controlling the actuators associated to one cylinder. - watchdog circuits for monitoring the main CPU

F02D 41/28

Interface circuits

Definition statement

This place covers:

Interface circuit between the control unit and associated elements, e.g. multiplexers or signal processing units between sensors and control unit.

F02D 41/3023

{a mode being the stratified charge spark-ignited mode}

Definition statement

This place covers:

Gasoline engines with a stratified charge, which is usually caused by injection late in the compression stroke and subsequent ignition.

Special rules of classification

Semi-stratified mode with injections in intake and compression stroke should additionally receive [F02D 41/402](#)

F02D 41/3029

{further comprising a homogeneous charge spark-ignited mode}

Definition statement

This place covers:

Engines with stratified and homogeneous modes

F02D 41/3035

{a mode being the premixed charge compression-ignition mode}

Definition statement

This place covers:

Engine control for engines wherein the mixture is partly or homogeneously premixed and then ignited by compression.

Also called HCCI for homogeneous charge compression ignition.

F02D 41/3041

{with means for triggering compression ignition, e.g. spark plug}

Definition statement

This place covers:

Means used to trigger the compression-ignition in premixed charge compression ignition engines, e.g.:

- injection of fluids or gases, e.g. water to delay ignition or pressurized air to create pressure wave-activation of a spark-plug to change the mixture composition- change of compression ratio shortly before TDC- laser ignition aid

F02D 41/3047

{said means being a secondary injection of fuel}

Definition statement

This place covers:

A second, small injection shortly before the compression stroke TDC to get local air-fuel ratio above self-ignition limit. Said fuel might also be ignited by spark to cause pressure increase and subsequent self-ignition of the homogeneous mixture

Special rules of classification

Multiple Injections per se, e.g. with a first injection during the negative valve overlap normally called activation injection, should be classified in [F02D 41/402](#)

F02D 41/3058**{the engine working with a variable number of cycles}****Definition statement***This place covers:*

Engines controlled to change from 2-cycle to 4-cycle or 6-cycle mode, e.g. by changing valve actuation and injection frequency

References**Informative references***Attention is drawn to the following places, which may be of interest for search:*

Engine conversions to change number of cycles	F02B 69/06
---	----------------------------

F02D 41/3064**{with special control during transition between modes}****Definition statement***This place covers:*

Special measures to avoid problems during combustion mode transitions, e.g. considering the delay between different actuators

F02D 41/3076**{with special conditions for selecting a mode of combustion, e.g. for starting, for diagnosing}****Definition statement***This place covers:*Conditions other than load/speed map for selecting one of a plurality of combustion modes
Adaptation of load/speed maps for selecting combustion modes**F02D 41/3082****{Control of electrical fuel pumps}****Special rules of classification**

Control of electrical low pressure pumps in common rail systems only ass additional information

F02D 41/32**of the low pressure type {([F02D 41/3082](#) takes precedence)}****Definition statement***This place covers:*

Control of fuel injection into intake manifold which is not air-mass based fuel injection control, i.e. essentially air density control after intake pressure and rpm is classified here

F02D 41/34

with means for controlling injection timing or duration (ignition timing [F02P 5/00](#))

References**Informative references**

Attention is drawn to the following places, which may be of interest for search:

Control of injection duration after air flow	F02D 41/18
Control of duration after manifold pressure	F02D 41/32
Injection timing	F02D 41/345

F02D 41/38

of the high pressure type

Definition statement

This place covers:

High pressure fuel injection control, e.g. control of fuel amount of electronically controlled direct injectors.

References**Informative references**

Attention is drawn to the following places, which may be of interest for search:

Electronic control of mechanical fuel pumps	F02D 41/406
---	-----------------------------

F02D 41/3836

{Controlling the fuel pressure}

Definition statement

This place covers:

Controlling the fuel pressure in the common rail, also setting of target values

F02D 41/3845

{by controlling the flow into the common rail, e.g. the amount of fuel pumped}

Definition statement

This place covers:

This includes both diverting the fuel directly from the high pressure pump and the control of fuel amount directed to the pump inlet via the so-called suction control valves

F02D 41/3854**{with elements in the low pressure part, e.g. low pressure pump}****Definition statement***This place covers:*

The amount of fuel supplied to the high pressure pump is (indirectly) controlled using the low pressure fuel pump, fuel pressure regulators in the low pressure part of the common rail system or other elements in the low pressure circuit

References**Limiting references***This place does not cover:*

Suction control valve in the pump inlet	F02D 41/3845
---	------------------------------

F02D 41/3863**{by controlling the flow out of the common rail, e.g. using pressure relief valves}****Definition statement***This place covers:*

Common rail pressure control via pressure relief valves.

F02D 41/3872**{characterised by leakage flow in injectors}****Definition statement***This place covers:*

Short actuations of the injector which cause some fuel to leak out of the injector and return to the fuel tank. These actuations are usually too short to cause fuel injector opening and therefore supply of fuel to engine.

F02D 41/407**{of the in-line type}****Definition statement***This place covers:*

Fuel amount control in in-line injection pumps

F02D 41/408**{of the distributing type}****Definition statement***This place covers:*

Fuel amount control in distributor injector pumps

F02D 43/00

Conjoint electrical control of two or more functions, e.g. ignition, fuel-air mixture, recirculation, supercharging, exhaust-gas treatment (electrical control of exhaust gas treating apparatus per se [F01N 9/00](#))

References**Limiting references**

This place does not cover:

Conjoint control of several parameters	F02D 41/00
--	----------------------------

Special rules of classification

Used only for documents controlling the air amount after fuel amount. control of several parameters should be classified in right individual groups under [F02D 41/00](#).

F02D 45/00

Electrical control not provided for in groups [F02D 41/00](#) - [F02D 43/00](#) (electrical control of exhaust gas treating apparatus [F01N 9/00](#); electrical control of one of the functions; ignition, lubricating, cooling, starting, intake-heating, see relevant subclasses for such functions)

Special rules of classification

This group is not used