

D03D

WOVEN FABRICS; METHODS OF WEAVING; LOOMS

Definition statement

This place covers:

Woven fabrics or weaving processes resulting in particular woven fabrics. These aspects are covered by [D03D 1/00](#) - [D03D 27/00](#).

Specific types of weaving machines or processes to operate such weaving machines. These aspects are covered by [D03D 29/00](#) - [D03D 47/00](#).

Details or features common to different types of weaving machines. These aspects are covered by [D03D 49/00](#) and [D03D 51/00](#).

References

Limiting references

This place does not cover:

Devices for warp yarn preparation (i.e. creeling, warping, beaming or leasing)	D02H
Shedding mechanisms	D03C
Auxiliary apparatuses combined with or associated with looms	D03J 1/00
Post treatments of fabrics	D06B , D06C , D06M

Informative references

Attention is drawn to the following places, which may be of interest for search:

Knitting	D04B
Felts, non-woven fabrics, waddings and their manufacturing	D04H
Sewing	D05B
Embroidering and tufting	D05C

Special rules of classification

Class [D06](#) takes precedence over this subclass in respect of processes involving both weaving and finishing steps and in respect of the finished fabrics.

In this subclass, further classification in indexing scheme [D10B](#) for aspects relating to textiles is required.

A method of weaving is classified in the group designating the fabric woven unless the method is characterised by the operation of a particular loom rather than by the production of a particular fabric. In this case, the method is classified in the group for the loom.

In this subclass, if there is any doubt as to which of the essential features is the most important (this is usually the most restrictive feature), the groups designating woven fabrics should be considered in the order in which they appear at each level of indentation, except that groups designating woven pile fabrics are to be considered as taking precedence over groups designating other woven fabrics.

D03D 1/00

Woven fabrics designed to make specified articles

Definition statement

This place covers:

Woven fabrics or weaving methods where the structure or method makes the fabric specifically suitable for a certain application (e.g. a warp and weft yarn density can make a fabric specifically suitable for use as an airbag).

References

Informative references

Attention is drawn to the following places, which may be of interest for search:

Special materials for outerwear	A41D 31/00
Floor fabrics	A47G 27/00 , D06N 7/00
Fire-resistant or fire-fighters' clothes	A62B 17/003
Fibrous reinforcements in composites	B29C 70/222 , B29C 70/224 , B29C 70/24
Papermaking fabrics	D21F 1/0036 , D21F 1/0054 , D21F 1/105 , D21F 1/12 , D21F 1/16 , D21F 7/10
Surfaces simulating grass	E01C 13/08
Window screens	E06B
Lighting devices or systems using a string or strip of light sources, e.g. lighting webs	F21S 4/00

Special rules of classification

Documents should only be classified here if the invention is specifically directed to the weaving of the product and has general relevance for weaving. Otherwise the documents should only be classified in the relevant application fields (see informative references).

The following Indexing Codes should be used in [D03D 1/00](#):

- physical properties [D10B 2401/00](#);
- wearing apparel [D10B 2501/00](#);
- domestic or personal use [D10B 2503/00](#);
- industrial use [D10B 2505/00](#);
- sport or military use [D10B 2507/00](#);
- medical or hygiene use [D10B 2509/00](#).

D03D 1/0005**{Woven fabrics for safety belts}****References****Informative references***Attention is drawn to the following places, which may be of interest for search:*

Safety belts in general	B60R 22/00
-------------------------	----------------------------

D03D 1/0023**{Mops or wipes}****References****Informative references***Attention is drawn to the following places, which may be of interest for search:*

Cleaning cloths	A47L 1/15 , A47L 13/16 .
-----------------	--

D03D 1/0043**{for elongated members, i.e. sleeves}****Definition statement***This place covers:*

Protective sleeves for elongated members, e.g. for insulating conductive wires or for covering reinforcement wires in clothing. The sleeve can be woven as a tubular fabric or as a flat fabric which is subsequently rolled-up into a tubular shape.

Illustrative example of subject matter classified in this group:

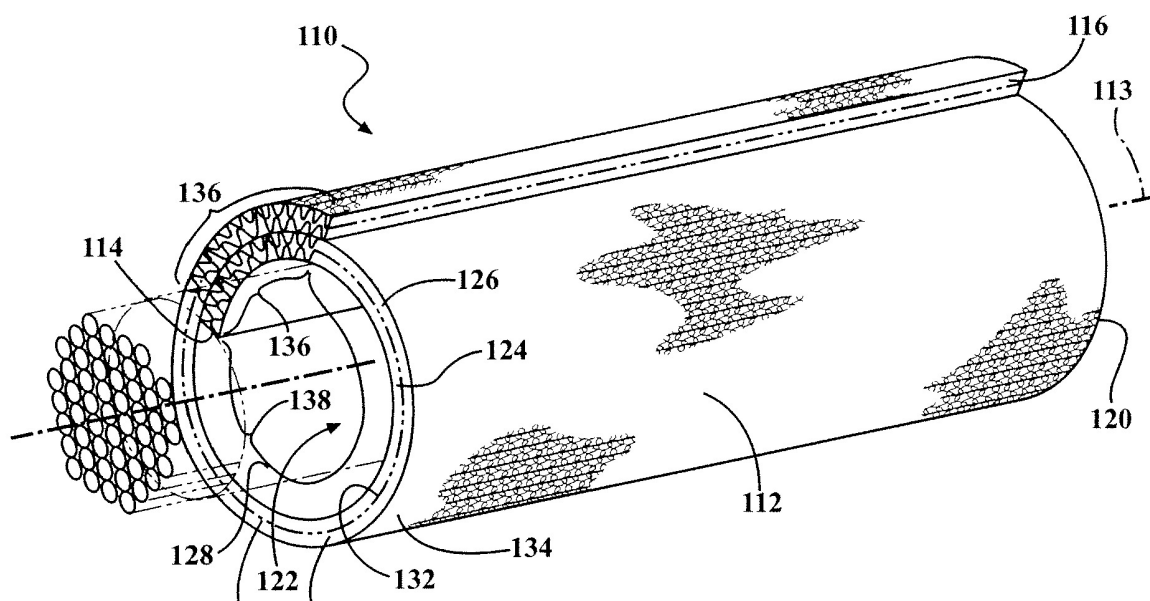

References

Informative references

Attention is drawn to the following places, which may be of interest for search:

Woven tubular fabrics characterised by their shape	D03D 3/02
Protecting means for wire harnesses	B60R 16/0215
Protective tubings or conduits	H02G 3/04

Special rules of classification

Protective sleeves that are integrally woven as tubular fabrics should additionally be classified in [D03D 3/02](#).

D03D 1/0047

{Camouflage fabrics}

Definition statement

This place covers:

Camouflage fabrics e.g. for visual or thermal camouflage, e.g. with heat reflective properties.

D03D 1/0052

{Antiballistic fabrics}

Definition statement

This place covers:

Antiballistic woven fabrics or woven layers.

References

Informative references

Attention is drawn to the following places, which may be of interest for search:

Armoured or projectile- or missile garments, composite protection fabrics	F41H 1/02
Armour or armour plates comprising fibre or fabric reinforced layers	F41H 5/00 , F41H 5/0435 , F41H 5/0478

D03D 1/0064

{Noise dampening}

Definition statement

This place covers:

Fabrics designed to dampen noise.

D03D 1/007**{UV radiation protecting}****Definition statement***This place covers:*

Fabrics normally used to provide protection from sun or UV-radiation, i.e. sunscreens.

D03D 1/0076**{Photovoltaic fabrics}****Definition statement***This place covers:*

Woven fibre structures for solar cells.

D03D 1/0082**{Fabrics for printed circuit boards}****References****Informative references***Attention is drawn to the following places, which may be of interest for search:*

Flexible or folded printed circuits	H05K 1/189
-------------------------------------	----------------------------

D03D 1/0088**{Fabrics having an electronic function}****References****Informative references***Attention is drawn to the following places, which may be of interest for search:*

Garments adapted to accommodate electronic equipment	A41D 1/002
--	----------------------------

D03D 1/0094**{Belts ([D03D 1/0005](#) takes precedence)}****Definition statement***This place covers:*

All kinds of woven belts not covered by other groups.

References**Limiting references***This place does not cover:*

Tapes or ribbons	D03D 3/005
------------------	----------------------------

Informative references

Attention is drawn to the following places, which may be of interest for search:

Conveyor belts with reinforcing layers	B65G 15/34
Reinforcement belts for tyres	D10B 2505/022 , B60C 9/00
Driving belts in general	F16G 1/00

D03D 1/02**Inflatable articles****References****Informative references**

Attention is drawn to the following places, which may be of interest for search:

Airbags in general	B60R 21/16
Airbags characterised by their material	B60R 21/235

D03D 1/06**Curtain heading tapes****References****Informative references**

Attention is drawn to the following places, which may be of interest for search:

Means for forming pleats in curtains on curtain rods or rails	A47H 13/14
---	----------------------------

D03D 1/08**Ladder tapes (ladder tapes for venetian blinds [E06B 9/382](#))****Definition statement**

This place covers:

Two tapes which are connected by threads or connecting layers which are designed to hold slats of fabric, wood, plastic or metal that adjust by rotating from an open position to a closed position by allowing slats to overlap. The scope of this group also covers full width fabrics having tapes or fabrics connected by connecting layers whereby the connecting layers themselves constitute the slats that adjust that adjust by rotating from an open position to a closed position by allowing the slats to overlap.

Illustrative example of subject matter classified in this group (DE-A-105 17 46):

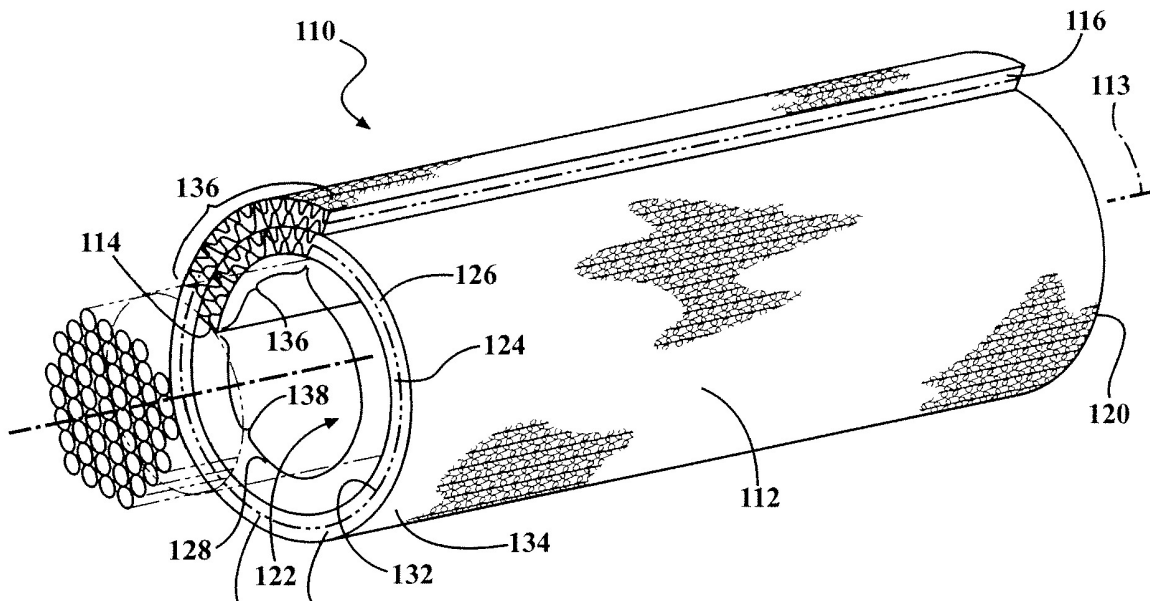

References

Informative references

Attention is drawn to the following places, which may be of interest for search:

Details of ladder tapes or ladder chains for venetian blinds	E06B 9/382
--	----------------------------

D03D 3/00

Woven fabrics characterised by their shape

Definition statement

This place covers:

Fabrics which are woven to assume a special shape. This shape is not achieved by cutting or by any other post-processing step.

D03D 3/005

{Tapes or ribbons not otherwise provided for ([D03D 1/0005](#), [D03D 1/0011](#), [D03D 1/06](#), [D03D 1/08](#), [D03D 1/0094](#) take precedence)}

Definition statement

This place covers:

Tapes or ribbons not covered by other groups.

References

Limiting references

This place does not cover:

Safety belts	D03D 1/0005
Tapes for labels	D03D 1/0011

Belts	D03D 1/0094
Curtain heading tapes	D03D 1/06
Ladder tapes	D03D 1/08
Slide fastener tapes	D10B 2501/063

Informative references

Attention is drawn to the following places, which may be of interest for search:

Smallware looms	D03D 35/00 , D03D 47/02
-----------------	---

D03D 3/02

Tubular fabrics

Definition statement

This place covers:

Sleeve-like structures integrally woven in a tubular shape.

Illustrative example of subject matter classified in this group:

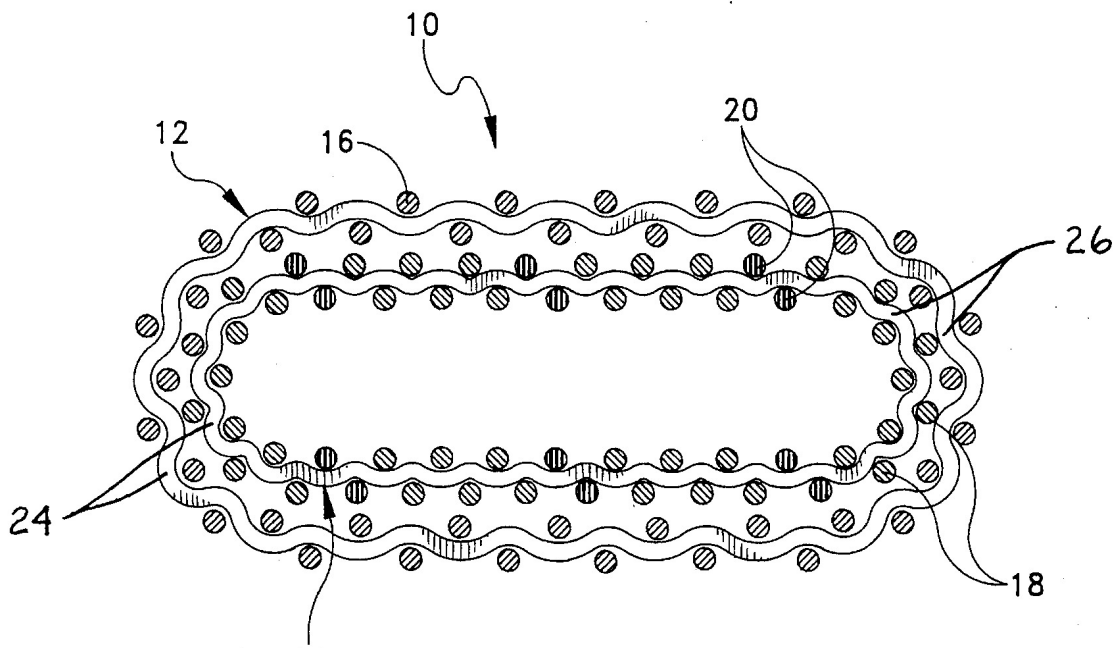

References

Informative references

Attention is drawn to the following places, which may be of interest for search:

Vascular stents	A61F 2/82 , D10B 2509/06
Hoses made of fibres or threads	F16L 11/02
Insulation of connections using a heat shrinking insulating sleeve	H01R 4/72

Special rules of classification

Tubular woven fabrics that are intended for use as protective sleeves should additionally be classified in [D03D 1/0043](#).

Glossary of terms

In this place, the following terms or expressions are used with the meaning indicated:

Tubular fabric	A tubular woven fabric is either a (1) flat-woven multi-layer fabric integrally woven as a tube, i.e. with a continuous weft connecting the layers at both edges of the fabric, and only at the edges, or (2) an integrally circular woven fabric. Woven fabrics where the tubular shape is achieved after weaving, e.g. a flat woven fabric rolled up into a tubular shape, are not considered as tubular fabrics.
----------------	---

D03D 3/04

Endless fabrics

Definition statement

This place covers:

Endless fabrics, for example belts without a seam.

References

Limiting references

This place does not cover:

Papermaking fabrics	D21F 1/0036 , D21F 1/0054 , D21F 1/105 , D21F 1/12 , D21F 1/16 , D21F 7/10
---------------------	---

D03D 5/00

Selvages

Definition statement

This place covers:

Selvages, i.e. the side edges of woven fabrics.

References

Limiting references

This place does not cover:

Means to form selvages	D03D 47/40
Selvage jacquards	D03C 3/18
Leno shedding mechanisms	D03C 7/00
Selvage shedding mechanisms not forming part of main shedding	D03C 11/00

D03D 7/00**Woven fabrics designed to be resilient, i.e. to recover from compressive stress****Definition statement***This place covers:*

Multi-layered fabrics with elastic yarns connecting the individual layers in particular spacer fabrics.

D03D 9/00**Open-work fabrics (ladder-tape fabrics [D03D 1/08](#))****Definition statement***This place covers:*

Net like fabrics, with spaced warp and weft yarns, whereby the spacing is resulting from the weaving process.

References**Limiting references***This place does not cover:*

Net like structure woven using a leno weave	D03D 19/00
---	----------------------------

Informative references*Attention is drawn to the following places, which may be of interest for search:*

Filtering materials	B01D 39/08
Wire nets	B21F 27/00
Mesh fabrics as backings	B24D 11/02

D03D 11/00**Double or multi-ply fabrics not otherwise provided for****Definition statement***This place covers:*

Fabrics with multiple woven layers connected by warp or weft yarns, the layers being all of the same size, i.e. the dimension of the layers does not vary in the z-direction (i.e. the direction perpendicular to the warp and weft yarns).

References**Limiting references***This place does not cover:*

Multi-ply fabrics in which the length or width direction is limited to a predetermined dimension in order to create a rectangular or other three dimensional shape	D03D 25/005
Layered products whereby the layers are not connected by warp or weft yarns, i.e. layers connected by lamination	B32B 5/26

Informative references

Attention is drawn to the following places, which may be of interest for search:

Fibrous reinforcements for composites	B29C 70/222 , B29C 70/224 , B29C 70/24
---------------------------------------	--

D03D 13/00

Woven fabrics characterised by the special disposition of the warp or weft threads, e.g. with curved weft threads, with discontinuous warp threads, with diagonal warp or weft

References**Informative references**

Attention is drawn to the following places, which may be of interest for search:

Fabrics with non-woven perpendicular yarns, which can be connected by woven weft and/or warp yarns	D04H 3/04
--	---------------------------

D03D 13/004

{with weave pattern being non-standard or providing special effects}

Definition statement

This place covers:

Fabrics characterised by their weave pattern.

Fabrics having a non-standard weave pattern (standard weave patterns are e.g. plain weave, twill, basket, sateen etc).

Fabrics having a standard weave pattern but new effects are created due to the pattern.

D03D 13/006

{With additional leno yarn}

Definition statement

This place covers:

Fabric patterns with a leno binding yarn additional to the weft and warp yarns, e.g. for fixing yarns in reinforcement fabrics.

References**Limiting references**

This place does not cover:

Leno yarns in selvages	D03D 5/00
Gauze or leno woven fabrics (i.e. fabrics consisting mainly of leno yarns in the warp)	D03D 19/00

D03D 13/008

{characterised by weave density or surface weight}

Definition statement

This place covers:

Fabrics characterised by the yarn fineness, the weave density or surface weight.

D03D 15/00

Woven fabrics characterised by the material, structure or properties of the fibres, filaments, yarns, threads or other warp or weft elements used

Definition statement

This place covers:

Woven fabrics characterised by the material, structure or properties of the fibres, filaments, yarns, threads or other warp or weft elements used.

References

Informative references

Attention is drawn to the following places, which may be of interest for search:

Yarns per se	D02G
Knitted fabrics characterised primarily by the use of a particular thread material	D04B 1/14 , D04B 21/14

Special rules of classification

Documents should only be classified here if the invention is directed to the weaving and has general relevance for weaving. Documents should not be classified here if a woven fabric is mentioned only by way of example.

Classification with an appropriate Indexing symbol in [D10B](#) is also used in [D03D 15/00](#).

D03D 15/208

cellulose-based

Special rules of classification

Cellulose-based fibres or filaments, e.g. vegetable fibres are also classified with an appropriate Indexing symbol in [D10B 2201/00](#).

D03D 15/233

protein-based, e.g. wool or silk

Definition statement

This place covers:

Fabrics with warp and/or weft yarns or threads comprising protein-based fibres or filaments, e.g. wool fibres.

Special rules of classification

Protein-based fibres or filaments, e.g. animal fibres are also classified with an appropriate Indexing symbol in [D10B 2211/00](#).

D03D 15/235**{Cashmere or silk}****Definition statement**

This place covers:

Fabrics with warp and/or weft yarns or threads comprising cashmere or silk fibres.

D03D 15/247**{Mineral}****Definition statement**

This place covers:

Fabrics with warp and/or weft yarns or threads comprising a mineral like rock or basalt.

References**Informative references**

Attention is drawn to the following places, which may be of interest for search:

Yarns or threads made from mineral substances	D02G 3/16
---	---------------------------

D03D 15/258**Noble metal****Definition statement**

This place covers:

Fabrics with warp and/or weft yarns or threads comprising "noble metal", e.g. gold, silver, platinum or iridium.

D03D 15/267**Glass****References****Informative references**

Attention is drawn to the following places, which may be of interest for search:

Yarns or threads made from glass or the like	D02G 3/18
--	---------------------------

D03D 15/283

synthetic polymer-based, e.g. polyamide or polyester fibres (cellulose-based artificial fibres [D03D 15/225](#))

References

Limiting references

This place does not cover:

Cellulose-based artificial fibres	D03D 15/225
-----------------------------------	-----------------------------

Special rules of classification

- Fibres or filaments made from polymers obtained by reactions only involving carbon-to-carbon unsaturated bonds are also classified with an appropriate Indexing symbol in [D10B 2321/00](#).
- Fibres or filaments made from polymers obtained otherwise than by reactions only involving carbon-to-carbon unsaturated bonds, e.g. polycondensation products, are also classified with an appropriate Indexing symbol in [D10B 2331/00](#).

D03D 15/292

Conjugate, i.e. bi- or multicomponent, fibres or filaments

Definition statement

This place covers:

Fabrics with warp and/or weft yarns or threads comprising conjugate, i.e. bi- or multicomponent fibres or filaments, e.g. core-sheath or sea-island type.

References

Informative references

Attention is drawn to the following places, which may be of interest for search:

Multicomponent, e.g. blended yarns or threads	D03D 15/47
Conjugate filaments	D01D 5/30
Conjugated, i.e. bi- or multicomponent, artificial filaments or the like; Manufacture thereof	D01F 8/00

D03D 15/33

Ultrafine fibres, e.g. microfibres or nanofibres

Definition statement

This place covers:

Fabrics with warp and/or weft fibres or filaments including fine staple fibres or filaments (typically less than 1 dtex).

D03D 15/41**with specific twist****References*****Informative references****Attention is drawn to the following places, which may be of interest for search:*

Yarns with characteristics dependent on the amount or direction of twist	D02G 3/26
--	---------------------------

D03D 15/43**with differing diameters****Definition statement***This place covers:*

Fabrics comprising yarns or threads of different diameters or linear densities.

D03D 15/44**with specific cross-section or surface shape****Definition statement***This place covers:*

Fabrics with warp and/or weft yarns or threads defined by a particular cross-sectional shape, e.g. flat, oval or asymmetrical.

D03D 15/46**Flat yarns, e.g. tapes or films****Definition statement***This place covers:*

Fabrics with warp and/or weft yarns or threads which are flat or tape-like or films.

References***Informative references****Attention is drawn to the following places, which may be of interest for search:*

Looms for weaving flat yarns	D03D 41/008
------------------------------	-----------------------------

D03D 15/47

multicomponent, e.g. blended yarns or threads (multicomponent fibres or filaments [D03D 15/292](#))

Definition statement

This place covers:

Fabrics with warp and/or weft yarns or threads comprising yarns of different materials, e.g. cabled or plied yarns, core spun yarns, wrapped yarns or sheath spun over core yarns.

References**Limiting references**

This place does not cover:

Multicomponent fibres or filaments	D03D 15/292
------------------------------------	-----------------------------

Glossary of terms

In this place, the following terms or expressions are used with the meaning indicated:

Bicomponent or multicomponent yarns or threads	Yarns or threads having two or more different components either by chemical means (e.g. core-sheath or island-in-sea) or mechanical means (e.g. cored, coated or cabled.)
--	---

D03D 15/49

textured (chenille [D03D 27/18](#)); curled; crimped

Definition statement

This place covers:

Fabrics with warp and/or weft yarns or threads comprising textured, curled or crimped yarns.

References**Limiting references**

This place does not cover:

Chenille	D03D 27/18
----------	----------------------------

Informative references

Attention is drawn to the following places, which may be of interest for search:

Yarns or threads having slubs, knops, spirals, loops, tufts or other irregular or decorative effects	D02G 3/34
--	---------------------------

D03D 15/497**{Knitted threads}****Definition statement***This place covers:*

Fabrics with warp and/or weft yarns or threads of knitted strips.

References**Informative references***Attention is drawn to the following places, which may be of interest for search:*

Warp knitted yarns	D04B 21/202
--------------------	-----------------------------

D03D 15/507**magnetic****Definition statement***This place covers:*

Fabrics with warp and/or weft yarns or threads having magnetic properties.

D03D 15/513**heat-resistant or fireproof****References****Informative references***Attention is drawn to the following places, which may be of interest for search:*

Special materials for outerwear against fire and heat	A41D 31/08
Fire-resistant or fire-fighters' clothes	A62B 17/00
Heat-resistant, fireproof or flame-retardant yarns or threads	D02G 3/443

D03D 15/533**antistatic; electrically conductive****References****Informative references***Attention is drawn to the following places, which may be of interest for search:*

Yarns or threads with antistatic properties	D02G 3/441
Floors or floor coverings specially adapted for discharging static charges	H05F 3/025

D03D 15/54**coloured****Definition statement**

This place covers:

Fabrics with effects due to the use of warp and/or weft yarns or threads of specific colour(s).

References**Informative references**

Attention is drawn to the following places, which may be of interest for search:

Yarns with coloured effects	D02G 3/346
-----------------------------	----------------------------

D03D 15/56**elastic****Definition statement**

This place covers:

Fabrics with warp and/or weft yarns or threads comprising elastic or stretchable yarns or threads.

References**Informative references**

Attention is drawn to the following places, which may be of interest for search:

Woven fabrics having elastic or stretch properties due to the manner of weaving	D03D 17/00
Elastic yarns or threads	D02G 3/32

D03D 15/587**adhesive; fusible****References****Informative references**

Attention is drawn to the following places, which may be of interest for search:

Yarns with the adhesive being one component of the yarn	D02G 3/402
---	----------------------------

D03D 15/63**Straps, e.g. leather straps****Definition statement**

This place covers:

Fabrics with warp and/or weft components formed from strips of materials, e.g. leather straps.

References

Informative references

Attention is drawn to the following places, which may be of interest for search:

Threads formed from strip material other than paper	D02G 3/06
---	---------------------------

D03D 15/65

Paper

Definition statement

This place covers:

Fabrics with warp and/or weft yarns or threads of paper, often paper strips.

References

Informative references

Attention is drawn to the following places, which may be of interest for search:

Paper yarns or threads	D02G 3/08
------------------------	---------------------------

D03D 15/69

{Threads with beads}

Definition statement

This place covers:

Fabrics with warp and/or weft threads containing beads, pearls and the like.

D03D 17/00

Woven fabrics having elastic or stretch properties due to manner of weaving (fabrics using stretchable or elastic threads [D03D 15/56](#))

Definition statement

This place covers:

Woven fabrics having elastic or stretch properties due to the manner of weaving.

References

Limiting references

This place does not cover:

Fabrics using stretchable or elastic threads	D03D 15/56
--	----------------------------

D03D 19/00

Gauze or leno-woven fabrics

Definition statement

This place covers:

Fabrics comprising mainly leno yarns outside the selvages. The leno yarns are normally provided to ensure that the warp yarns do not slide along the weft yarns in loosely woven fabrics.

References

Limiting references

This place does not cover:

Selvages with or without leno yarns	D03D 5/00
Fabric with a leno binding yarn additional to the weft and warp yarns, e.g. for fixing yarns in reinforcement fabrics	D03D 13/006
Leno shedding mechanisms	D03C 7/00

Informative references

Attention is drawn to the following places, which may be of interest for search:

Filtering materials	B01D 39/08
Wire nets	B21F 27/00
Mesh fabrics as backings	B24D 11/02

D03D 21/00

Lappet- or swivel-woven fabrics

Definition statement

This place covers:

Fabrics with yarns passing only over part of the width or length of the fabric.

Glossary of terms

In this place, the following terms or expressions are used with the meaning indicated:

Lappet	weaving is figured by the introduction of additional warp yarns which pass only over part of the length of the fabric
Swivel	weaving is figured by the introduction of additional weft yarns which pass only over part of the width of the fabric

D03D 23/00

General weaving methods not special to the production of any particular woven fabric or the use of any particular loom; Weaves not provided for in any other single group

Definition statement

This place covers:

Weaving methods of fabrics which are not specific for a certain loom.

D03D 25/00

Woven fabrics not otherwise provided for

Definition statement

This place covers:

Woven fabrics not otherwise provided for.

D03D 25/005

{Three-dimensional woven fabrics}

Definition statement

This place covers:

Integrally woven 3D-constructions. It also covers multi-ply fabrics in which the length or width direction is limited to a predetermined dimension in order to create a rectangular shape.

References**Limiting references**

This place does not cover:

Multi-ply fabrics which extend, apart from having a certain thickness, in two directions	D03D 11/00
--	----------------------------

Informative references

Attention is drawn to the following places, which may be of interest for search:

Fibrous reinforcements in composites	B29C 70/222 , B29C 70/224 , B29C 70/24
--------------------------------------	--

D03D 27/00

Woven pile fabrics

Definition statement

This place covers:

Woven pile fabrics.

References

Informative references

Attention is drawn to the following places, which may be of interest for search:

Carpets in general	A47G 27/02
--------------------	----------------------------

D03D 27/08

Terry fabrics

Definition statement

This place covers:

Terry fabrics, e.g. towels, beach robes.

D03D 27/10

Fabrics woven face-to-face, e.g. double velvet

Definition statement

This place covers:

Fabrics consisting of two layers which are connected by pile yarns, the two layers being simultaneously woven on the loom.

References

Informative references

Attention is drawn to the following places, which may be of interest for search:

Face to face fabrics which are not cut	D03D 7/00 , D03D 11/00
--	--

D03D 27/12

wherein pile tufts are inserted during weaving

Definition statement

This place covers:

In particular fabrics woven on Axminster looms.

D03D 27/18

Chenille fabrics

References

Informative references

Attention is drawn to the following places, which may be of interest for search:

Chenille threads	D02G 3/42
------------------	---------------------------

Glossary of terms

In this place, the following terms or expressions are used with the meaning indicated:

Chenille yarn	is manufactured by placing short lengths of yarn, called the "pile", between two "core yarns" and then twisting the yarn together. The edges of these piles then stand at right angles from the yarn's core, giving chenille both its softness and its characteristic look. Chenille will look different in one direction compared to another, as the fibres catch the light differently.
---------------	---

D03D 29/00

Hand looms

Definition statement

This place covers:

Looms where the weft thread is inserted by hand.

D03D 31/00

Lappet, swivel or other looms for forming embroidery-like decoration on fabrics

Glossary of terms

In this place, the following terms or expressions are used with the meaning indicated:

Lappet	weaving is figured by the introduction of additional warp yarns which pass only over part of the length of the fabric
Swivel	weaving is figured by the introduction of additional weft yarns which pass only over part of the width of the fabric

D03D 33/00

Multiple looms, i.e. two or more looms assembled together, whether or not they have mechanisms in common ([D03D 35/00](#) takes precedence)

Definition statement

This place covers:

Multiple looms, i.e. two or more looms assembled together, whether or not they have mechanisms in common.

D03D 35/00

Smallware looms, i.e. looms for weaving ribbons or other narrow fabrics ([D03D 47/00](#) takes precedence)

Definition statement

This place covers:

Smallware looms, i.e. looms for weaving ribbons or other narrow fabrics.

References

Informative references

Attention is drawn to the following places, which may be of interest for search:

Ribbons or narrow fabrics	D03D 3/005
---------------------------	----------------------------

D03D 37/00

Circular looms (looms for weaving separate fabrics disposed in a circle or polygon [D03D 33/00](#))

Definition statement

This place covers:

Looms where the weft inserting means follows a circular path.

D03D 39/00

Pile-fabric looms

Definition statement

This place covers:

Looms for weaving pile fabrics.

D03D 39/02

Axminster looms, i.e. wherein pile tufts are inserted during weaving

References

Informative references

Attention is drawn to the following places, which may be of interest for search:

Woven pile fabrics wherein pile tufts are inserted during weaving	D03D 27/12
---	----------------------------

D03D 39/04

Spool Axminster looms

Definition statement

This place covers:

Axminster looms where the yarn comes from a tube, actuated mechanically, without gripper.

References

Informative references

Attention is drawn to the following places, which may be of interest for search:

Methods or apparatus with yarn packages as yarn supply	B65H 49/02 or B65H 49/18
Creels	D02H 1/00

D03D 39/083

{Selecting mechanisms}

Definition statement

This place covers:

The tuft yarn selection in Axminster looms.

D03D 39/223

{Cloth control}

Definition statement

This place covers:

Cloth shifting type terry looms.

D03D 39/226

{Sley control}

Definition statement

This place covers:

Sley movement adjusting type terry looms.

D03D 41/00

Looms not otherwise provided for, e.g. for weaving chenille yarn; Details peculiar to these looms

Definition statement

This place covers:

Looms not otherwise provided for, e.g. for weaving chenille yarns.

D03D 41/005

{Linear-shed multiphase looms}

Definition statement

This place covers:

Looms with a rotor having multiple weft insertion channels in each of which a weft is inserted into the shed simultaneously.

Documents relating to the Sulzer rotor loom.

D03D 41/007

{Vertical looms}

Definition statement

This place covers:

Looms with a vertical arrangement of the warp yarns at the weft insertion position.

D03D 41/008**{Looms for weaving flat yarns}****Definition statement**

This place covers:

Looms especially adapted to weave fabrics with flat yarns in the warp or weft.

References**Informative references**

Attention is drawn to the following places, which may be of interest for search:

Fabrics using flat yarns	D03D 15/46
--------------------------	----------------------------

D03D 43/00**Looms with change-boxes****Definition statement**

This place covers:

Shuttle looms which have shuttle boxes for storing multiple shuttles, in particular with different weft yarns, from which the shuttles are selected in accordance with a specific pattern.

D03D 43/02**with drop boxes****Definition statement**

This place covers:

Change boxes with compartments in a non-rotary arrangement, in which the shuttles are dropped.

D03D 43/06**with rotary boxes****Definition statement**

This place covers:

Change boxes with compartments in a rotary arrangement, in which the shuttles are dropped.

D03D 45/00

Looms with automatic weft replenishment (automatic replenishment in smallware looms [D03D 35/00](#), in circular looms [D03D 37/00](#); bobbins rewound on loom [D03J 1/12](#))

Definition statement

This place covers:

Automatic replenishment of weft yarn stored in a shuttle.

D03D 47/00

Looms in which bulk supply of weft does not pass through shed, e.g. shuttleless looms, gripper shuttle looms, dummy shuttle looms (circular looms [D03D 37/00](#))

Definition statement

This place covers:

Looms in which the weft yarn is stored outside the shed (often at the side) and taken up by weft insertion means for introduction into the shed, e.g. rapier looms, needle looms and fluid jet looms.

D03D 47/02

wherein loops of continuous weft thread are inserted, i.e. double picks

Definition statement

This place covers:

Looms wherein loops of continuous weft thread are inserted, e.g. smallware looms where loops of weft yarn are normally inserted with a needle.

D03D 47/12

wherein single picks of weft thread are inserted, i.e. with shedding between each pick

Definition statement

This place covers:

Looms wherein single picks of weft thread are inserted, e.g. with a rapier.

D03D 47/125

{Weft holding devices (if the weft is reinserted in the next shed [D03D 47/48](#); in jet looms [D03D 47/308](#))}

Definition statement

This place covers:

Means for holding the weft at the side of the shed.

References**Informative references**

Attention is drawn to the following places, which may be of interest for search:

Stretching or holding the weft in jet looms	D03D 47/308
Forming selvages by inserting cut end of weft in next shed	D03D 47/48

D03D 47/20**Constructional features of the thread-engaging device on the inserters****Definition statement**

This place covers:

Details of rapier grippers.

D03D 47/233**{Carrying grippers}****Definition statement**

This place covers:

Carrying, giver or bringing grippers for transporting the weft to the middle of the shed.

Special rules of classification

Documents describing additionally the drawing gripper in detail are additionally classified in [D03D 47/236](#).

D03D 47/236**{Drawing grippers}****Definition statement**

This place covers:

Drawing, taker, pulling or receiving grippers for transporting the weft from the middle of the shed to the end of the shed.

Special rules of classification

Documents describing additionally the carrying gripper in detail are additionally classified in [D03D 47/233](#).

D03D 47/24

by gripper or dummy shuttle (travelling-wave-shed looms [D03D 47/26](#); inserting mechanisms for shuttles [D03D 49/24](#); gripper or dummy shuttles per se [D03J 5/06](#))

Definition statement

This place covers:

Projectile looms, where the shuttle does not carry a bobbin.

D03D 47/26**Travelling-wave-shed looms****Definition statement**

This place covers:

Looms having multiple phase shifted sheds and a rotary reed.

D03D 47/27**Drive or guide mechanisms for weft inserting****Definition statement**

This place covers:

Drive or guide means for weft thread insertion.

References**Limiting references**

This place does not cover:

Guide mechanisms for pneumatic looms (normally means for creating an air channel for weft insertion)	D03D 47/278
Carrying the weft thread with a fluid through the shed	D03D 47/28

Informative references

Attention is drawn to the following places, which may be of interest for search:

Drive means for shuttle looms	D03D 49/24
-------------------------------	----------------------------

Glossary of terms

In this place, the following terms or expressions are used with the meaning indicated:

In this group, the following terms are relevant for correct classification:

Rapier	means for carrying the weft thread through the shed with a rod (sometimes also called lance or needle) or a flexible band
Drive mechanism	the part outside the shed driving the means for carrying the weft thread through the shed
Guide mechanism	parts inside and outside the shed to guide the means for carrying the weft threads through the shed

D03D 47/271**{Rapiers}****Definition statement**

This place covers:

Rapiers, i.e. means to insert the weft thread with a flexible band or rod.

D03D 47/272**{Rapier bands}****Definition statement**

This place covers:

Details of the rapier band.

D03D 47/273**{Rapier rods}****Definition statement***This place covers:*

Details of the rapier rod.

References**Limiting references***This place does not cover:*

Needles for smallware looms	D03D 47/02
-----------------------------	----------------------------

Synonyms and Keywords*In the documents, the following words "rod", "lance" and "needle" are often used as synonyms.*

However, weft insertion needles as used in smallware looms are not considered to be rapier rods.

D03D 47/275**{Drive mechanisms}****Definition statement***This place covers:*

The part outside the shed driving the means for carrying the weft thread through the shed.

D03D 47/277**{Guide mechanisms (for shuttles [D03D 49/24](#))}****Definition statement***This place covers:*

Guides for all insertion means except shuttle. For example: grippers, bands, lances or dummy shuttles.

D03D 47/278**{for pneumatic looms}****Definition statement***This place covers:*

Means for creating an air channel for weft insertion.

D03D 47/3046**{Weft yarn selection}****Definition statement***This place covers:*

The weft yarn selection on air jet looms.

D03D 47/306**{Construction or details of parts, e.g. valves, ducts}****References****Informative references***Attention is drawn to the following places, which may be of interest for search:*

Lift valves with valve members of conical shape (i.e. throttle valves)	F16K 1/38
Operating means, releasing means using a motor in general	F16K 31/04

D03D 47/34**Handling the weft between bulk storage and weft-inserting means****Definition statement***This place covers:*

All aspects concerning the handling of the weft yarns from the weft yarn supply means (i.e. normally bobbins) up to (but not including) the weft insertion.

References**Informative references***Attention is drawn to the following places, which may be of interest for search:*

Methods and apparatuses for unwinding or paying-out filamentary material from packages in general	B65H 49/02 , B65H 49/18
Forwarding filamentary material	B65H 51/00
Guides for filamentary material	B65H 57/00
Guides for filamentary material adapted to prevent excessive ballooning	B65H 57/22

D03D 47/342**{knot detection}****Definition statement***This place covers:*

Systems for detecting wefts with faults such as knots.

Special rules of classificationIf the knot detection is part of a weft stop motion additionally the class [D03D 51/34](#) is given.

D03D 47/345**{Rotating bobbins}****Definition statement***This place covers:*

Bulk storage bobbins which are rotatable supported and/or driven for lateral unwinding without inducing twist to the yarn.

D03D 47/347**{Yarn brakes ([D03D 47/364](#) takes precedence)}****Definition statement***This place covers:*

Braking devices for weft yarns to be inserted.

References**Informative references***Attention is drawn to the following places, which may be of interest for search:*

Warp yarn tension regulation	D03D 49/04
Adjusting or controlling tension in filamentary material in general	B65H 59/00

D03D 47/36**Measuring and cutting the weft {; Devices for measuring and temporary storing the weft (cutting weft threads [D03D 49/70](#))}****References****Informative references***Attention is drawn to the following places, which may be of interest for search:*

Devices for temporarily storing filamentary material during forwarding in general	B65H 51/20
Applications or devices for metering predetermined lengths of running material (i.e. yarns) in general	B65H 61/00

D03D 47/362**{with yarn retaining devices, e.g. stopping pins ([D03D 47/367](#) takes precedence)}****References****Informative references***Attention is drawn to the following places, which may be of interest for search:*

Clamping devices (i.e. yarn stoppers) in general	B65H 63/088
--	-----------------------------

D03D 47/365**{Brushes}****Definition statement***This place covers:*

Braking bodies being constituted by a brush.

D03D 47/366**{Conical}****Definition statement***This place covers:*

(Frusto-) conical braking bodies.

D03D 47/368**{Air chamber storage devices}****Definition statement***This place covers:*

Feeding devices in which the weft is temporarily stored in an air chamber, e.g. as loops or coils.

D03D 47/369**{Communication systems}****Definition statement***This place covers:*

Communication systems between pre-winders and the loom.

References**Informative references***Attention is drawn to the following places, which may be of interest for search:*

Programme-control systems in general	G05B 19/00
--------------------------------------	----------------------------

D03D 47/38**Weft pattern mechanisms****References****Limiting references***This place does not cover:*

Pneumatic weft pattern mechanisms	D03D 47/3046
-----------------------------------	------------------------------

D03D 47/40**Forming selvedges****Definition statement**

This place covers:

Means, other than a separate shedding mechanism, necessary for the formation of selvedges, i.e. the side edges of woven fabrics.

References**Limiting references**

This place does not cover:

Elvedges	D03D 5/00
Selvedge jacquards	D03C 3/18
Selvedge shedding mechanisms not forming part of main shedding mechanism	D03C 11/00

D03D 49/00**Details or constructional features not peculiar to looms of a particular type (temples [D03J 1/22](#))****References****Informative references**

Attention is drawn to the following places, which may be of interest for search:

Sliding-contact bearings	F16C 27/02
Clutches in which the members have interengaging parts	F16D 11/00

D03D 49/022**{Protective hoods or curtains}****References****Informative references**

Attention is drawn to the following places, which may be of interest for search:

Climatic conditioning or removing lint or dust	D03J 1/002
--	----------------------------

D03D 49/12**Controlling warp tension by means other than let-off mechanisms****Definition statement**

This place covers:

Controlling warp tension by means other than let-off mechanisms, e.g. by cloth take-up.

References

Informative references

Attention is drawn to the following places, which may be of interest for search:

Back rest; lease rods; brest beams	D03D 49/22
------------------------------------	----------------------------

D03D 49/16

Warp supplied by creel

References

Informative references

Attention is drawn to the following places, which may be of interest for search:

Methods or apparatus in which yarn packages do not rotate	B65H 49/02
Methods or apparatus in which yarn packages rotate	B65H 49/18
Creels	D02H 1/00

D03D 49/22

Back rests; Lease rods; Brest beams

Definition statement

This place covers:

Bars which extend across the width of the warps or of the woven fabric.

D03D 49/70

Devices for cutting weft threads (cutting weft in looms with automatic weft replenishment [D03D 45/50](#); apparatus for slitting fabric [D03J 1/08](#))

Definition statement

This place covers:

The cutting of weft threads including the cutting of weft threads for removing selvages.

References

Limiting references

This place does not cover:

Removing of selvages not on the loom	D06H 7/06.
--------------------------------------	----------------------------

Informative references

Attention is drawn to the following places, which may be of interest for search:

Forming selvages	D03D 47/40.
------------------	-----------------------------

D03D 51/00

Driving, starting, or stopping arrangements; Automatic stop motions {(loom control associated with fabric inspection on the loom [D03J 1/007](#))}

References

Informative references

Attention is drawn to the following places, which may be of interest for search:

Controlling a group of looms	D03J 1/006
Clutches in which the members have interengaging parts	F16D 11/00 , F16D 11/16
Programme-control systems in general	G05B 19/00
Dynamo-electric machines (i.e. electric motors in general)	H02K
Communication between machines in general	H04L 29/00

D03D 51/005

{Independent drive motors (independent frame drives for dobbies [D03C 1/146](#), for other shedding mechanisms [D03C 13/02](#))}

Definition statement

This place covers:

Operation and synchronisation of independent motors in looms.

D03D 51/007

{Loom optimisation}

Definition statement

This place covers:

Controlling one or more looms, e.g. by speed variation, to find an optimal operating condition.

D03D 51/18

Automatic stop motions

Definition statement

This place covers:

Methods and their implementations to detect broken warp or weft yarns and to stop the weaving machine upon this detection.

References

Informative references

Attention is drawn to the following places, which may be of interest for search:

Warning or safety devices for yarns in general	B65H 63/00
--	----------------------------

D03D 51/20

Warp stop motions

Definition statement

This place covers:

Methods and their implementations to detect broken warp yarns and to stop the weaving machine upon this detection.

D03D 51/28

electrical

Definition statement

This place covers:

E.g. optical warp stop motions.

D03D 51/34

Weft stop motions

Definition statement

This place covers:

Methods and their implementations to detect broken weft yarns and to stop the weaving machine upon this detection.

References

Informative references

Attention is drawn to the following places, which may be of interest for search:

Knot detection	D03D 47/342
----------------	-----------------------------

D03D 51/40

Shuttle stop motions

Definition statement

This place covers:

Methods and their implementations to detect broken weft yarns which are inserted by a shuttle and to stop the weaving machine upon this detection.

D03D 51/44

acting on defective operation of loom mechanisms

Definition statement

This place covers:

Methods and their implementations to stop the weaving machine upon detection of failure in the operation of one or more of the loom mechanisms.