

B61K

OTHER AUXILIARY EQUIPMENT FOR RAILWAYS (energy storing brakes [B61H](#); protection of permanent way against weather influences [E01B](#); rail cleaning, snow ploughs [E01H](#))

Definition statement

This place covers:

All auxiliary devices and methods needed to make railways safer, faster and energy efficient.

B61K 1/00

**Transferring passengers, articles, or freight to and from moving trains;
Slipping or coupling vehicles from or to moving trains**

Definition statement

This place covers:

Transit systems and methods wherein passengers or freights board and exit during moving of vehicles or wherein rail vehicles are coupled/uncoupled during motion.

Following drawing shows one example (US2010307368):

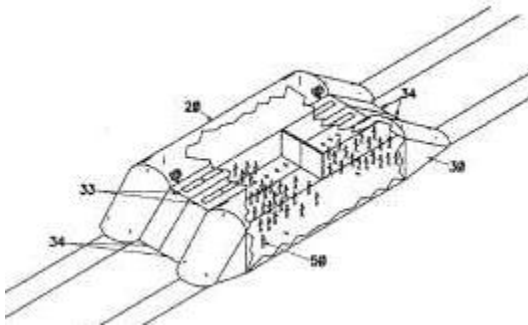

B61K 3/00

Wetting or lubricating rails or wheel flanges

Definition statement

This place covers:

Devices and methods for the application of lubricant onto the surface of rails or wheels.

Following drawing shows one example:

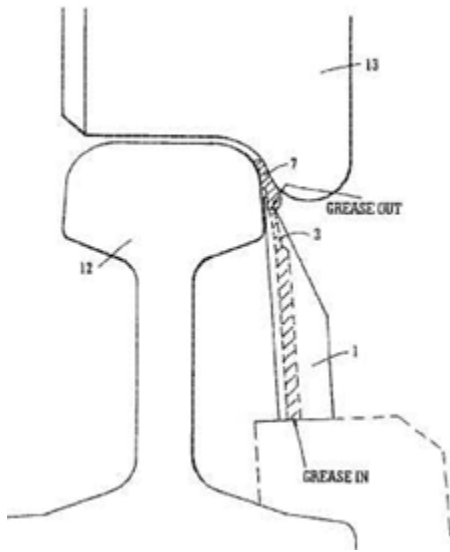

References

Informative references

Attention is drawn to the following places, which may be of interest for search:

Lubricating for vehicles	B60R 17/00
Lubrication for locomotives	B61C 17/08
Lubricating stick	C10M 105/00
Cleaning of rails	E01H
Lubricating in general	F16N

B61K 5/00

Apparatus for placing vehicles on the track; Derailers; Lifting or lowering rail vehicle axles or wheels (hoisting apparatus [B66](#))

Definition statement

This place covers:

The titles of this group are self-explanatory and do not need to be more specified.

Typical examples are:

- Portable derailing device.
- Device for lifting a rail vehicle while standing on the rail.
- Re-railer apparatus for placing derailed railway vehicle back onto the track.

Following drawings show two examples:

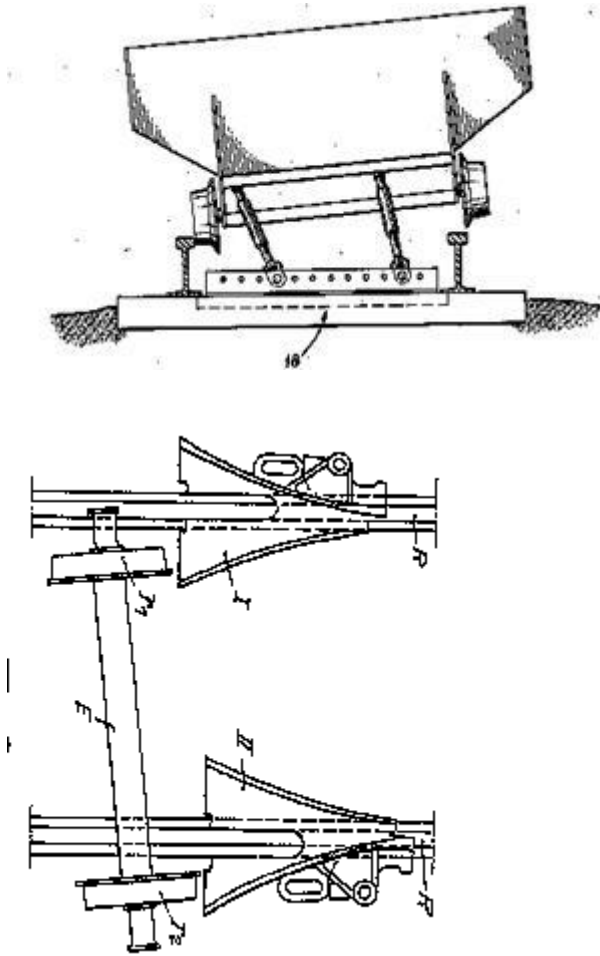

References

Informative references

Attention is drawn to the following places, which may be of interest for search:

Lifts	B66F 7/02
-------	---------------------------

B61K 7/00

Railway stops fixed to permanent way; Track brakes or retarding apparatus fixed to permanent way; Sand tracks or the like (skids, wedges, vehicle-mounted scotch blocks [B61H](#))

Definition statement

This place covers:

Devices and methods for retarding or stopping the movement of the railway vehicle, the devices and methods being located on the track.

Following drawings show two examples:

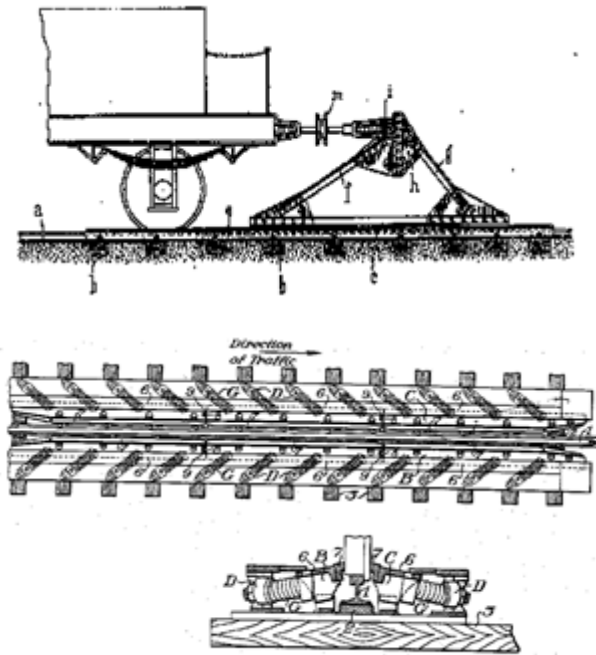

B61K 7/14

Sand or like tracks

Definition statement

This place covers:

Means combined with a track using sand or materials which have a retarding effect on the wheels.

Illustrative example of subject matter classified in this group:

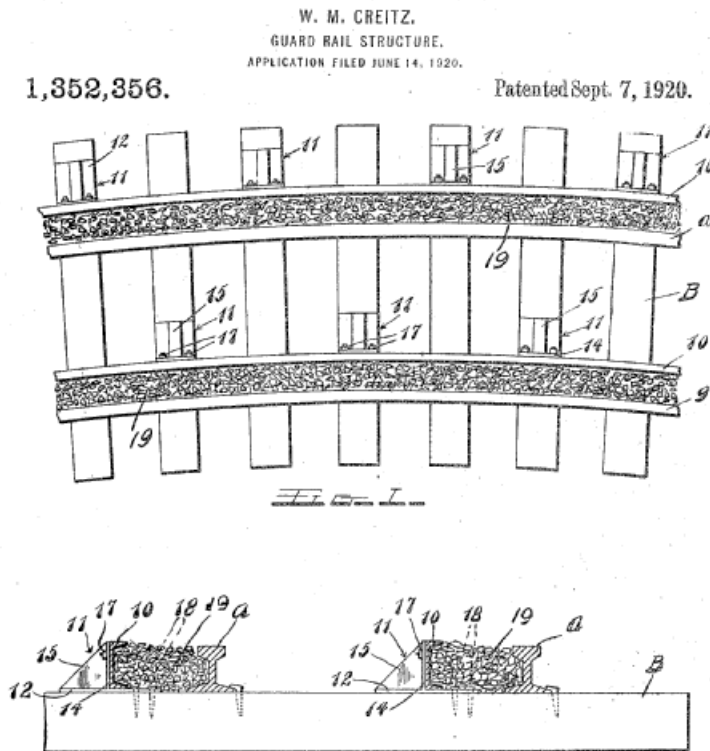

References

Limiting references

This place does not cover:

Sanding apparatus	B61C 15/10
-------------------	----------------------------

B61K 9/00

Railway vehicle profile gauges; Detecting or indicating overheating of components; Apparatus on locomotives or cars to indicate bad track sections; General design of track recording vehicles

Definition statement

This place covers:

The titles of this group are self-explanatory and do not need to be more specified.

Typical examples are:

- Method for detecting of imbalance in wheels of rail vehicle.
- Train wheel bearing temperature detection.
- Sensors for rail vehicle wheel bearing unit.
- Method and device for contactless measurement of the deformation and wear of railroad tracks.
- Acoustic monitoring of railcar running gear.

Following drawings show two examples:

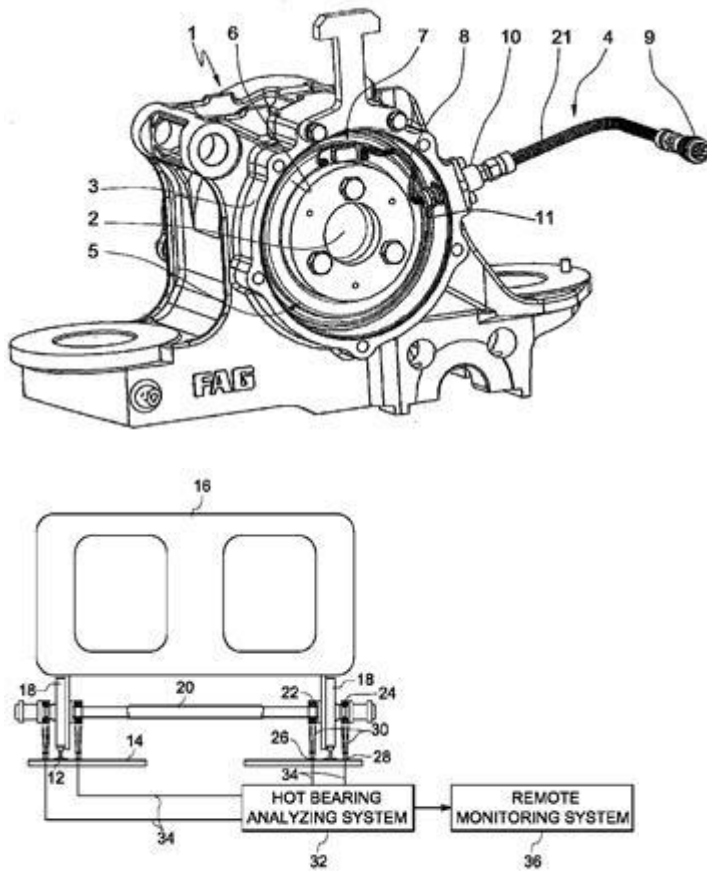

References

Informative references

Attention is drawn to the following places, which may be of interest for search:

Manufacturing wheels	B23B 5/28 , B24B 5/30 , B24B 21/02
Reconditioning wheels	B23B 5/32
Railway wheels	B60B 17/00
Brake-action in case of accident	B60T 7/124
Adjusting wheel-braking force	B60T 8/00
Control, warning or safety means	B61L
Track-building in general	E01B
Measuring for track-building purposes	E01B 35/00
Measuring arrangements	G01B 17/00
Weighing apparatus or method	G01G 19/04 - G01G 19/06
Measuring mechanical vibrations	G01H 17/00
Radiation pyrometry	G01J 5/0022
Casings	G01J 5/04
Thermometers for measuring temperature of moving bodies	G01K 13/04

Testing of railway vehicles	G01M 17/08 , G01M 17/10
Investigating in general	G01N
Investigating presence of flaws	G01N 25/72
Investigating of materials by using ultrasonic	G01N 29/00
Measuring speed	G01P 3/00 .
Navigation for trains	G01S 5/02

B61K 11/00

Serving peculiar to locomotives, e.g. filling with, or emptying of, water, sand, or the like at the depots (lifting or lowering axles or wheels [B61K 5/00](#); filling stations for steam or pneumatic accumulator locomotives [B61C 8/00](#); water or fuel supply fittings on locomotives [B61C 17/02](#); refuelling locomotives with solid fuels [B65G 67/18](#); washing or cleaning boilers [F28G](#))

Definition statement

This place covers:

The titles of this group are self-explanatory and do not need to be more specified.

Following drawings shows two examples:

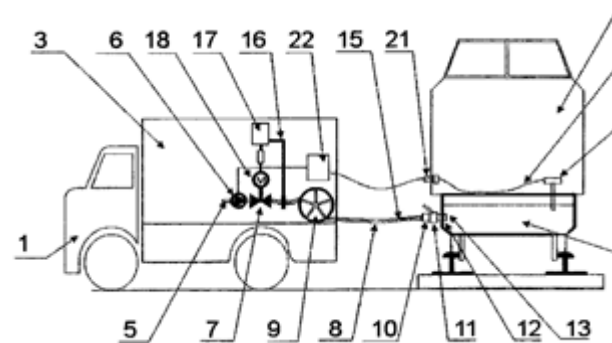
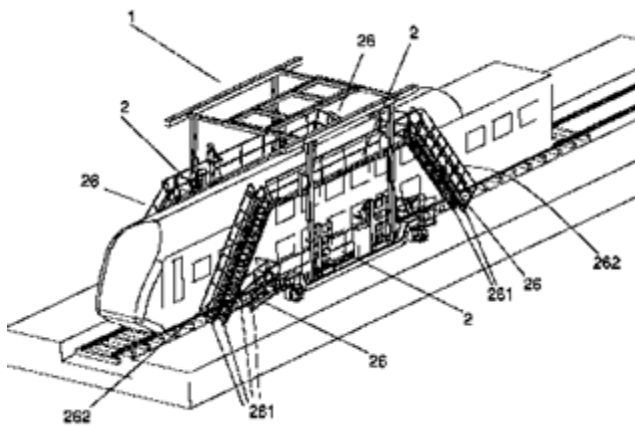

References

Informative references

Attention is drawn to the following places, which may be of interest for search:

Transport or storage devices	B65G
Conveying materials in bulk	B65G 53/00

B61K 13/00

Other auxiliaries or accessories for railways (safety belts or harnesses
[A62B 35/00](#))

Definition statement

This place covers:

Other auxiliary devices and methods that are not in [B61K 1/00](#) - [B61K 11/00](#).

Following drawing shows one example:

