

B61C

LOCOMOTIVES; MOTOR RAILCARS (vehicles in general [B60](#); frames or bogies [B61F](#); special railroad equipment for locomotives [B61J](#), [B61K](#))

Definition statement

This place covers:

General design features or items of locomotives and motor railcars, and non-electric features of electric locomotives. Locomotive or motor railcars are vehicles that pull other vehicles and are provided with a drive unit.

References

Limiting references

This place does not cover:

Frames or bogies	B61F
Special railroad equipment for locomotives	B61J , B61K

Informative references

Attention is drawn to the following places, which may be of interest for search:

Vehicles in general	B60
---------------------	---------------------

B61C 1/00

Steam locomotives or railcars (engines [F01](#); characterised by power transmissions [B61C 9/00](#); boilers [F22B](#))

Definition statement

This place covers:

Improvement of devices of the steam-driven locomotive and motor railcars.

Typical examples are:

- Improvements of steam-driven locomotives to allow better articulation.
- Improvements of the locomotive boiler.
- Improvements of the throttle valves for high pressure steam locomotives.
- Arrangement of locomotive parts to improve visibility of the driver.

Following drawing shows one example:

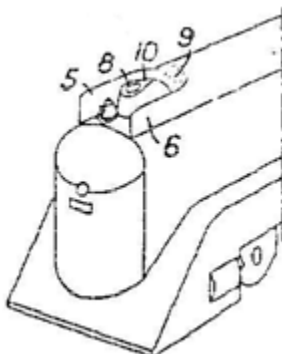

References

Limiting references

This place does not cover:

characterised by power transmissions	B61C 9/00
--------------------------------------	---------------------------

Informative references

Attention is drawn to the following places, which may be of interest for search:

Locomotives with combined steam and other types of engine, e.g. IC engine	B61C 7/04
Engines	F01
Steam engine plants	F01K15/02B
Boilers	F22B

B61C 3/00

Electric locomotives or railcars (characterised by power transmission [B61C 9/00](#); electrical features [B60L](#); [H02](#))

Definition statement

This place covers:

General design of locomotives of the electric type, and electric locomotives with battery power.

Following drawing shows an example:

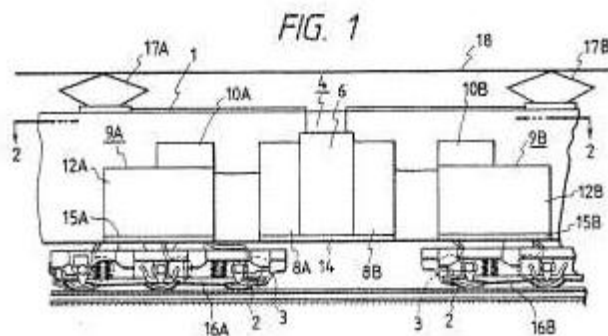

References

Limiting references

This place does not cover:

characterised by power transmission	B61C 9/00
-------------------------------------	---------------------------

Informative references

Attention is drawn to the following places, which may be of interest for search:

Electrical features	B60L , H02
Electric propulsion, e.g. circuits, devices	B60L 15/00

For tramway	B61D 13/00
-------------	----------------------------

B61C 5/00

Locomotives or motor railcars with IC engines or gas turbines (characterised by power transmission [B61C 9/00](#); engines [F02](#))

Definition statement

This place covers:

General design and improvements aspects of locomotives with IC (Internal combustion engine) or gas turbine.

Following drawing shows one example:

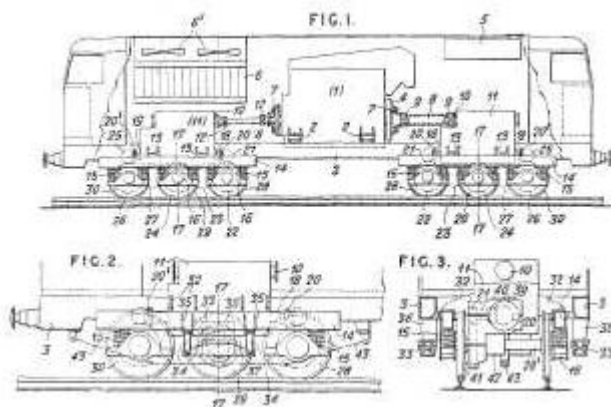

References

Limiting references

This place does not cover:

characterised by power transmission	B61C 9/00
-------------------------------------	---------------------------

Informative references

Attention is drawn to the following places, which may be of interest for search:

Filtering, cooling, or silencing cooling air	F01P 11/12
Engines	F02

B61C 5/02

Arrangement or disposition of intakes and apparatus for supplying, circulating, and filtering air for combustion and engine-cooling purposes

Definition statement

This place covers:

Arrangement or disposition of air intakes for combustion or engine-cooling;

Arrangement or disposition of apparatus for supplying, circulating or filtering of air for combustion or engine-cooling

Example (US2666497):

Arrangement of a ventilating and filtering system for a diesel-electric driven locomotive.

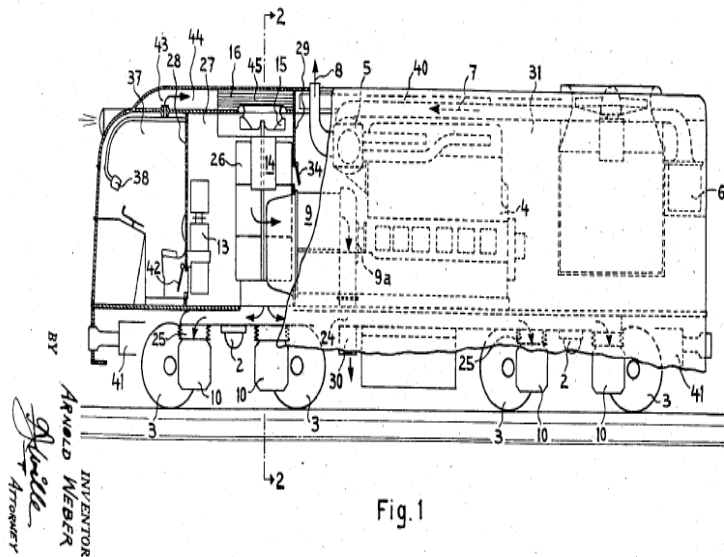

References

Informative references

Attention is drawn to the following places, which may be of interest for search:

Arrangement or disposition of driving cabins, footplates or engine room	B61C 17/04
---	----------------------------

B61C 7/00

Other locomotives or motor railcars

Definition statement

This place covers:

Locomotives or motor railcars that are not of the steam or electric type or not provided with an IC (internal combustion) engines or gas turbines.

Such locomotives could be:

- Hybrid locomotives with regenerative energy storage system.
- Locomotives comprising a main driving engine and an additional driving engine of a different type.
- Locomotives driven by compressed air.
- Flywheel energy storage combined with a prime motor.

References

Informative references

Attention is drawn to the following places, which may be of interest for search:

Hybrid propulsion systems	B60K 6/00
---------------------------	---------------------------

B61C 8/00

Filling stations for steam- or pneumatic-accumulator locomotives or motor railcars

Definition statement

This place covers:

Devices specially adapted for emptying, washing-out or refilling locomotives boilers.

Following drawing shows one example:

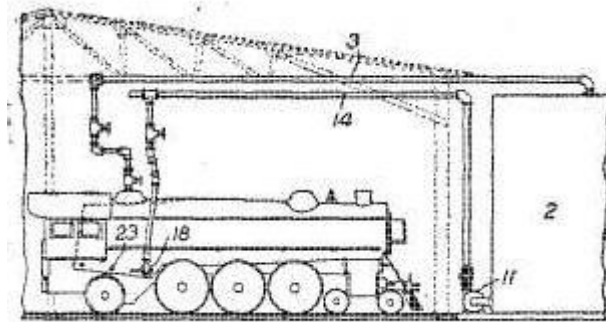

B61C 9/00

Locomotives or motor railcars characterised by the type of transmission system used; Transmission systems specially adapted for locomotives or motor railcars (machine elements [F16](#))

Definition statement

This place covers:

Transmission systems of locomotives of the steam or electric type or locomotives provided with an IC engines or gas turbines. This main-group covers apparatus and methods to determine the transfer of power from the motor unit to the driven wheels. Such apparatus are for example:

- Gear units for locomotives.
- Direct drive electric motor for wheelset.
- Electrohydraulic railway vehicle drive.
- Elastic drive coupling for drive wheel.

Following drawings show two examples:

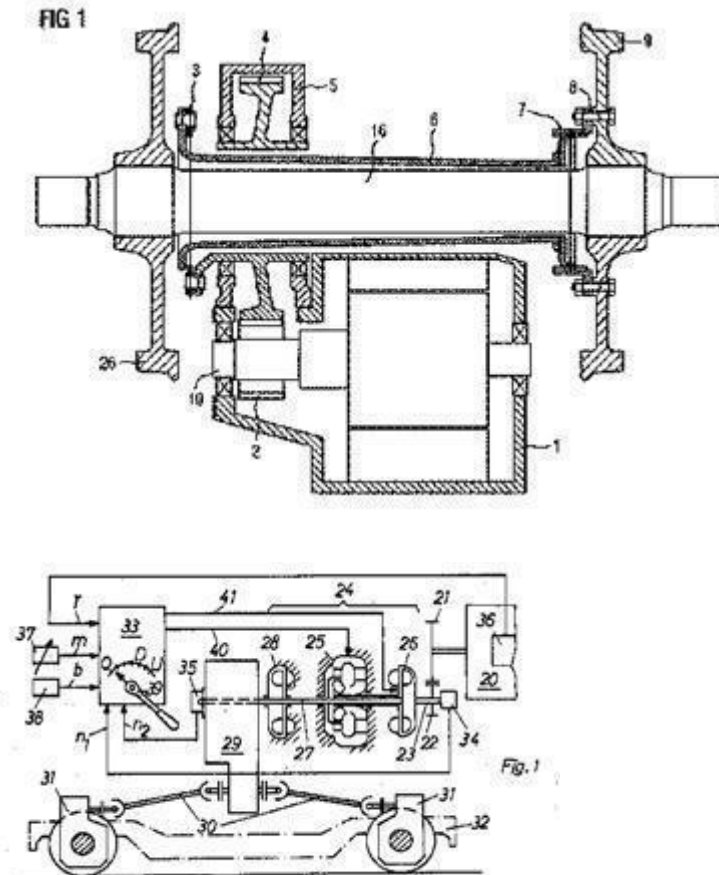

References

Informative references

Attention is drawn to the following places, which may be of interest for search:

Machine elements	F16
Combination of mechanical gearing with fluid gearing	F16H 47/00
Motor engine	H02K

B61C 11/00

Locomotives or motor railcars characterised by the type of means applying the tractive effort; Arrangement or disposition of running gear other than normal driving wheel (constructions wheels [B60B](#))

Definition statement

This place covers:

Locomotives or motor railcars wherein the tractive effort is not directly applied on normal driving wheels.

Typical examples are:

- Transportation system using magnetic belt propulsion.

Following drawings show two examples:

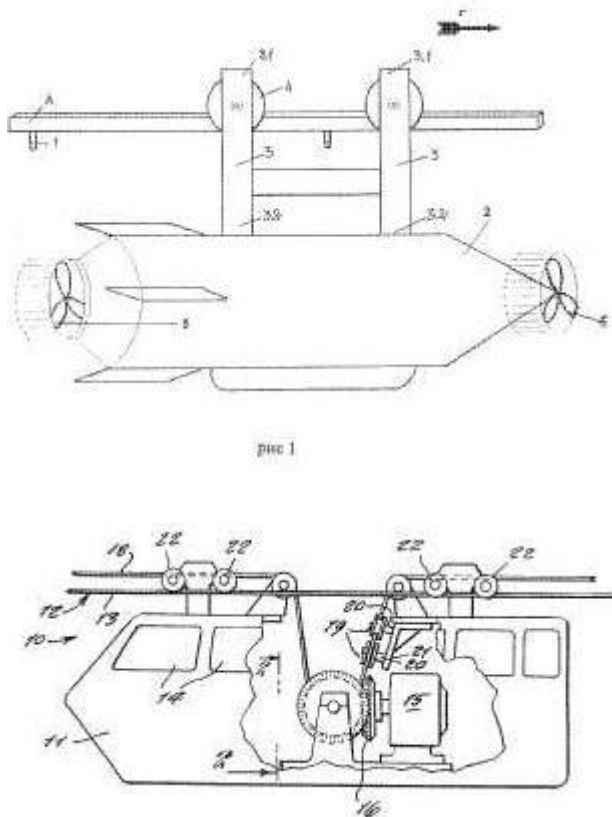

References

Informative references

Attention is drawn to the following places, which may be of interest for search:

Constructions wheels	B60B
Racks	F16H 55/26

B61C 13/00

Locomotives or motor railcars characterised by their application to special systems or purposes ([B61C 11/00](#) takes precedence; self-propelled scaffold cars, break-down cranes, inspection trolleys [B61D 15/00](#); general design of track recording vehicles [B61K 9/00](#))

Definition statement

This place covers:

Locomotives or motor railcars that are not of the conventional type, thus for special applications.

Typical examples are:

- Locomotives for towing ships.
- Article sorter with self-driving transport base.

Following drawing shows one example:

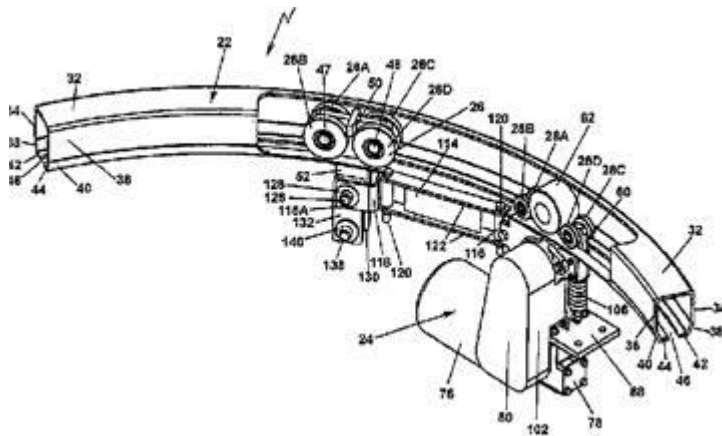

References

Limiting references

This place does not cover:

Locomotives or motor railcars characterised by the type of means applying tractive effort	B61C 11/00
Self-propelled scaffold cars, break-down cranes, inspection trolleys	B61D 15/00
General design of track recording vehicles	B61K 9/00

B61C 15/00

Maintaining or augmenting the starting or braking power by auxiliary devices and measures; Preventing wheel slippage; Controlling distribution of tractive effort between driving wheels (propelling locomotives or motor railcars by special means [B61C 11/00](#); driving wheels with non-slipping devices [B60B](#); brakes [B61H](#); wetting or lubricating rails [B61K](#))

Definition statement

This place covers:

All devices and methods to improve the rail-wheel contact of a locomotive or motor railcar.

Typical examples are:

- Devices for spraying antislip material.
- Piston control for sanding systems.
- System preventing a wheel flat.
- Friction control between wheel and rail.
- Magnet coil assembly for increasing the traction.

Following drawing shows one example:

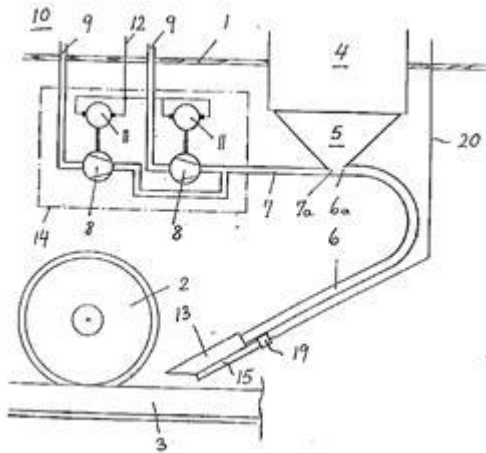

References

Limiting references

This place does not cover:

Propelling locomotives or motor railcars by special means	B61C 11/00
Wetting or lubricating rails	B61K

Informative references

Attention is drawn to the following places, which may be of interest for search:

Driving wheels with non-slipping devices	B60B
Brakes	B61H

B61C 17/00

Arrangement or disposition of parts; Details or accessories not otherwise provided for; Use of control gear and control systems

Definition statement

This place covers:

Arrangement or disposition of mechanical or electric parts in the locomotive. This main-group includes also methods and systems for controlling the locomotive.

Typical examples are:

- Locomotive engine housing arrangement.
- Radio control systems for locomotives.
- Ventilation grille for railway vehicle engine.
- Comfort improvement of the driver cabin.
- Battery mounting structure, hybrid propulsion.
- Fuel efficiency improvements for locomotives.

Following drawing shows one example:

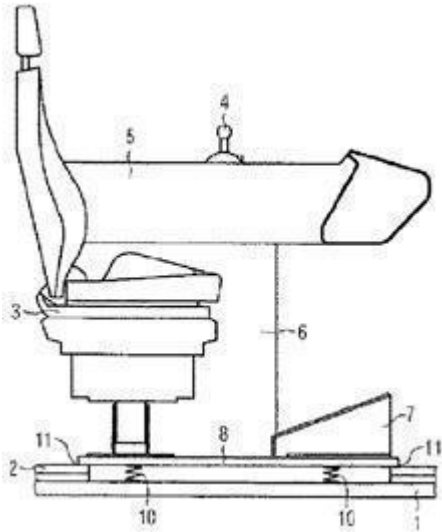

References

Informative references

Attention is drawn to the following places, which may be of interest for search:

Tanks for vehicles	B60K 15/00
Dead-man's devices	B60L 3/02
Remote controlling of the vehicle	B60L 5/32 , B60L 15/40
Installation of electric cables	H02G 3/00
TV systems and cameras	H04N 7/18
Cooling	H05K 7/00

B61C 17/04

**Arrangement or disposition of driving cabins, footplates or engine rooms;
Ventilation thereof (driving cabins and accessories [B61D](#))**

Definition statement

This place covers:

- the location as the composition of the driving cabin in the locomotive or motor railcar;
- the construction of floors or steps on the locomotive or motor railcar;
- the design of engine rooms;
- the ventilation of the driving cabin or the engine rooms.

Example (DE20111859U): Arrangement of a driver's stand

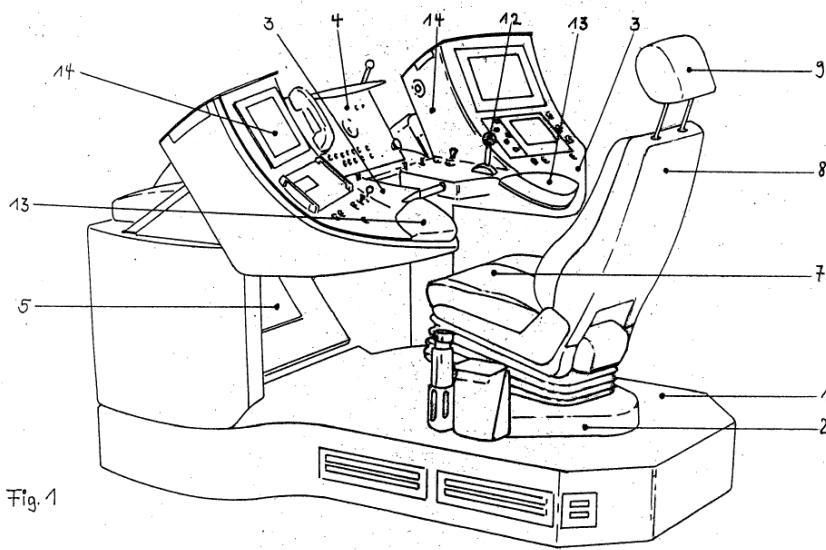

Example (EP0783987): Ventilation of the driver's cabin

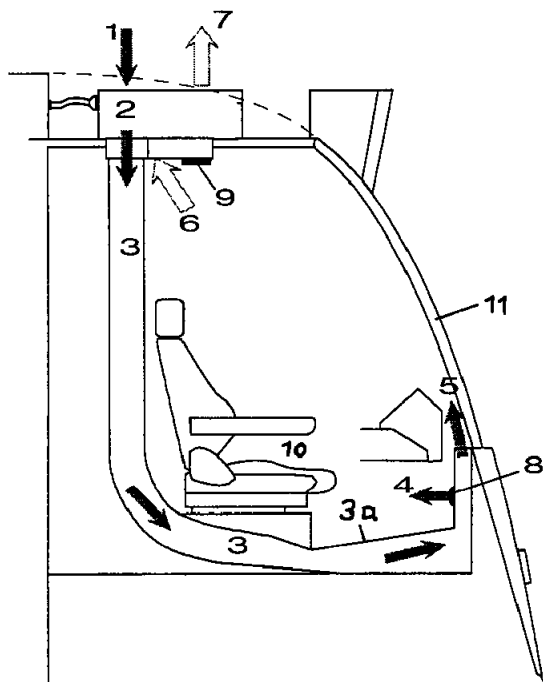

Example (US4067264): Locomotive having doors (24) with access to a footplate (21) along the length of each side of the engine compartment.

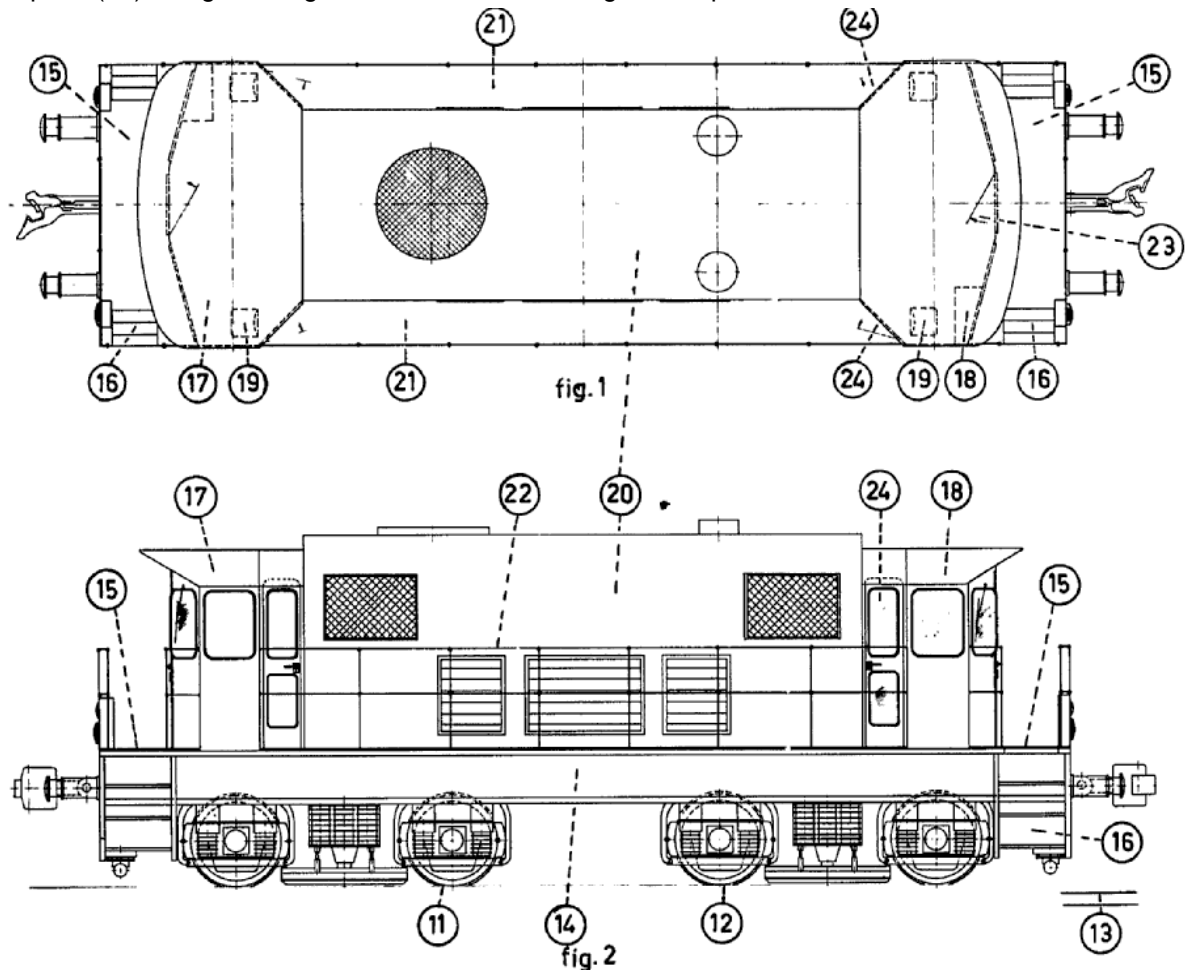

References

Limiting references

This place does not cover:

Driving cabins and accessories	B61D
--------------------------------	----------------------

Informative references

Attention is drawn to the following places, which may be of interest for search:

Supplying, circulating, and filtering air for combustion and engine-cooling purposes	B61C 5/02
Engine rooms	B60K

B61C 17/08

Lubrication systems (in general [F16N](#))

Definition statement

This place covers:

Lubrication systems specially adapted for rail vehicles

Example (US2738242): Lubricators for traction motor suspension bearings of diesel locomotives.

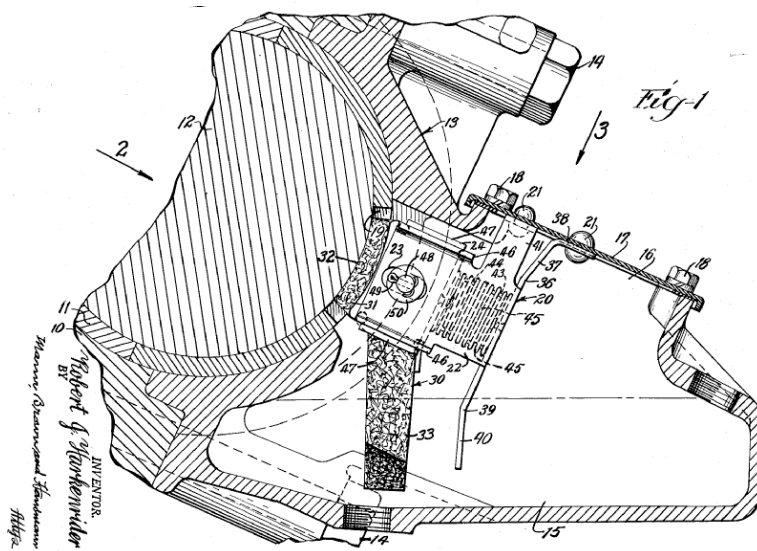

References

Informative references

Attention is drawn to the following places, which may be of interest for search:

Wetting or lubricating rails or wheel flanges	B61K 3/00
Lubrication in general	F16N

B61C 17/12

Control gear; Arrangements for controlling locomotives from remote points in the train or when operating in multiple units (control from points outside the train [B61L 3/00](#); fluid-actuated telemotors, servomotors [F15B](#); control devices in general [G05](#))

Definition statement

This place covers:

Remote control of locomotives, e.g. in a switchyard;

Control of multiple remote units by a single control device or by multiple control devices.

Example (US2005205720): Remotely controlled locomotive in a switchyard using radio transmitting devices for remote control by rail yard personnel.

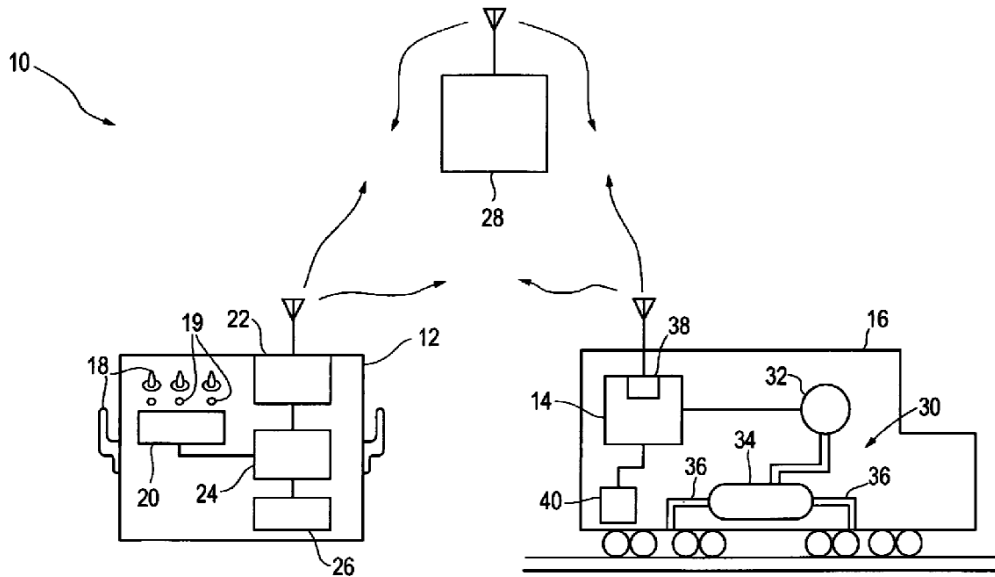

Example:

Control lever (2) which can be moved to one of several different positions to control the traction and braking unit of the railway.

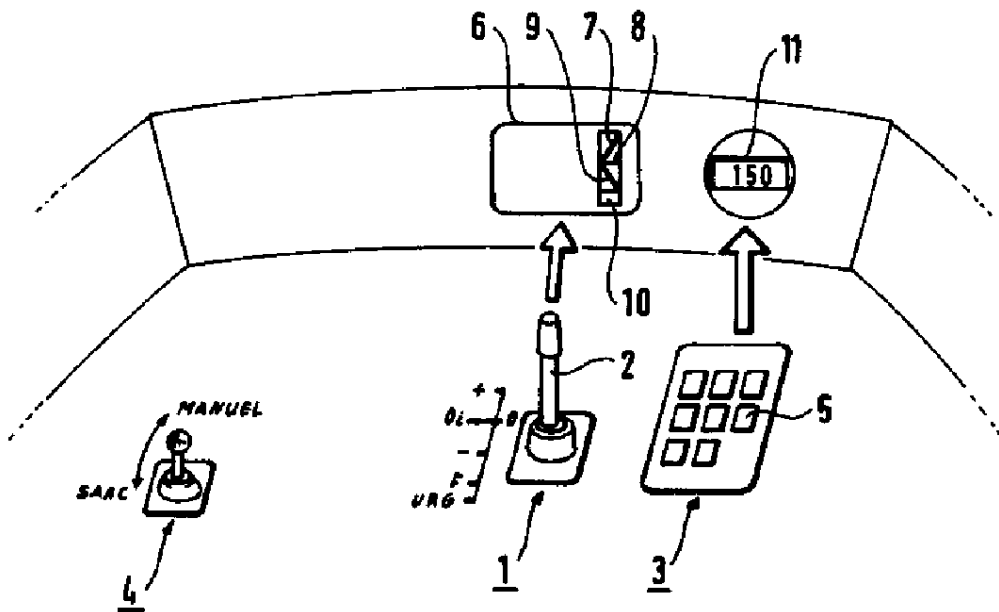

References

Informative references

Attention is drawn to the following places, which may be of interest for search:

Arrangement or mounting of propulsion units or of transmissions in vehicles	B60K
Control from points outside the train	B61L 3/00
Fluid-actuated telemotors, servomotors	F15B

Control devices in general	G05
----------------------------	---------------------