

B33Y

ADDITIVE MANUFACTURING, i.e. MANUFACTURING OF THREE-DIMENSIONAL [3-D] OBJECTS BY ADDITIVE DEPOSITION, ADDITIVE AGGLOMERATION OR ADDITIVE LAYERING, e.g. BY 3-D PRINTING, STEREO LITHOGRAPHY OR SELECTIVE LASER SINTERING

Definition statement

This place covers:

Technologies involving the use or application of processes or apparatus that produce three-dimensionally shaped structures by selectively depositing successive layers of material one upon another. In particular it covers processes, apparatus, materials, and other aspects of additive manufacturing, i.e., making, repairing, or modifying articles of manufacture by the selective application of multiple layers of material. The applied layers may be applied directly, as in a printing process, or by selective solidification of material onto a substrate or previously developed layers, for example, by selective sintering of a particulate.

Relationships with other classification places

In order to be considered additive manufacturing for this subclass each layer of material successively applied must essentially be formed directly on the previously applied layer of material, or on a substrate or support in the case of the first applied layer. In this regard, laminating premade layers together is not an aspect of additive manufacturing, and is classified per se in [B32B 37/00](#).

Likewise, build-up welding, for the purpose of restoring dimensional integrity to worn objects, is not an aspect of additive manufacturing, and is classified per se in [B23K 9/04](#) or [B23K 26/34](#). This subclass does cover build-up welding that creates objects per se, or missing or broken pieces of existing objects.

References

Informative references

Attention is drawn to the following places, which may be of interest for search:

Preparation of cocoa products	A23G
Processes for laying down cocoa products, e.g. chocolate in moulds or drop-by-drop on a surface, optionally with the associated heating, cooling, portioning, cutting cast-tail, anti-drip processes	A23G 1/0066
Preparation of food or foodstuffs	A23L 5/00
Moulded food or foodstuffs	A23P 30/10
Making of dental prostheses	A61C 13/00
Coating apparatus, in general	B05C
Coating processes, in general	B05D
Manufacture of workpieces or articles from metallic powder characterised by the manner of compacting or sintering	B22F 3/00
Manufacture of work-pieces or articles from metallic powder by selective deposition modelling	B22F 10/00
Direct sintering or melting	B22F 10/20
Producing shaped articles from ceramic or cementitious material	B28B 1/00
Additive manufacturing of shaped articles from ceramic or cementitious material	B28B 1/001

Shaping by coating a mould, core or other substrate, i.e. by depositing material and stripping-off the shaped article	B29C 41/00
Additive manufacturing of shaped articles from plastics	B29C 64/00
Moulding by agglomeration	B29C 67/02
Forme preparation	B41C 1/00
Typewriters or selective printers	B41J 2/00
Braille printing	B41M 3/16
Superimposing layers to produce ornamental structures	B44C 3/02
Sintering of ceramic materials	C04B 35/64
Culture of undifferentiated human, animal or plant cells	C12N 5/00
General methods for three-dimensional culture of undifferentiated human, animal or plant cells	C12N 5/0062
Coating by vacuum evaporation, by sputtering or by ion implantation of the coating forming material	C23C 14/00
Photosensitive materials	G03C , G03F 7/004
Photomechanical production of patterned surfaces	G03F 7/00
Electrographic processes using a charge pattern	G03G 13/00
Programme-control systems for surface or curve machining, making 3D objects, e.g. desktop manufacturing	G05B 19/4099
General purpose image data processing	G06T 1/00
Image acquisition in general	G06T 1/0007
Image enhancement for 2D or 3D images	G06T 5/00
Image analysis for 2D or 3D images	G06T 7/00
Image coding, e.g. from bit-mapped to non bit-mapped	G06T 9/00
3D [Three dimensional] image rendering	G06T 15/00
3D [Three dimensional] modelling, e.g. data description of 3D objects	G06T 17/00
Manipulating 3D models or images for computer graphics	G06T 19/00
Geography, e.g. relief models	G09B 25/06
Electron-beam or ion-beam tubes for localised application of thin layers on objects	H01J 37/3178
Manufacture of semiconductor or otherwise not provided for electric solid state devices	H01L 21/00
Manufacturing printed circuits by printing of conductive patterns	H05K 3/12
Manufacturing printed circuits by ink-jet printing of conductive patterns	H05K 3/125

Special rules of classification

- This subclass is for obligatory supplementary classification of subject matter already classified as such in other classification places, when the subject matter contains an aspect of additive manufacturing.
- The classification symbols of this subclass are not listed first when assigned to patent documents.

Glossary of terms

In this place, the following terms or expressions are used with the meaning indicated:

3D printing	Additive manufacturing where the buildup of successive layers of material includes the use of a printer-like device having a servo controlled head for dispensing materials that form the layers, similar to that used by inkjet printers
Stereolithography	Additive manufacturing technique where the successive layers of material are formed by selectively hardening regions of polymeric material successively applied to the structure, typically by the use of laser light.

Synonyms and Keywords

In patent documents, the following abbreviations are often used:

SLS	Selective laser sintering
DTM	Desktop manufacturing
LOM	Laminated Object Modelling
3DP, 3D-printing	Three-dimensional printing
SFF	Solid Freeform Fabrication
FDM	Fused Deposition Modelling
3DD	Three-dimensional deposition
SDM	Selective Deposition Modelling
LDM	Layered deposition modelling
3DM	Three-dimensional modelling
BPM	Ballistic Particle Modelling

B33Y 10/00

Processes of additive manufacturing

Definition statement

This place covers:

Processes and methods for manufacturing objects using additive manufacturing techniques.
Illustrative example of subject matter classified in this group:

(US 2010/0255213)

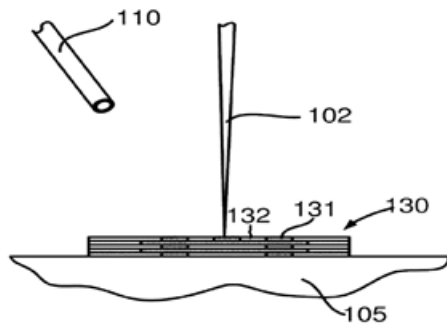

FIG. 2C

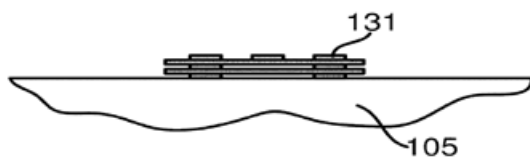

FIG. 2D

B33Y 30/00

Apparatus for additive manufacturing; Details thereof or accessories therefor

Definition statement

This place covers:

- Machines and systems for carrying out additive manufacturing methods to produce objects
- Subcombinations of machines that carry out additive manufacturing methods to produce objects
- Accessories for machines that carry out additive manufacturing methods. Accessories include things attachable to or used in conjunction with an additive manufacturing machine that have a direct association with the additive manufacturing machine, per se. Examples of accessories included in this group are devices to protect operators from harm by additive manufacturing machines, platforms to support structures being manufactured, and devices for calibrating additive manufacturing machines.

Illustrative example of subject matter classified in this group:

(US 2007/0023977)

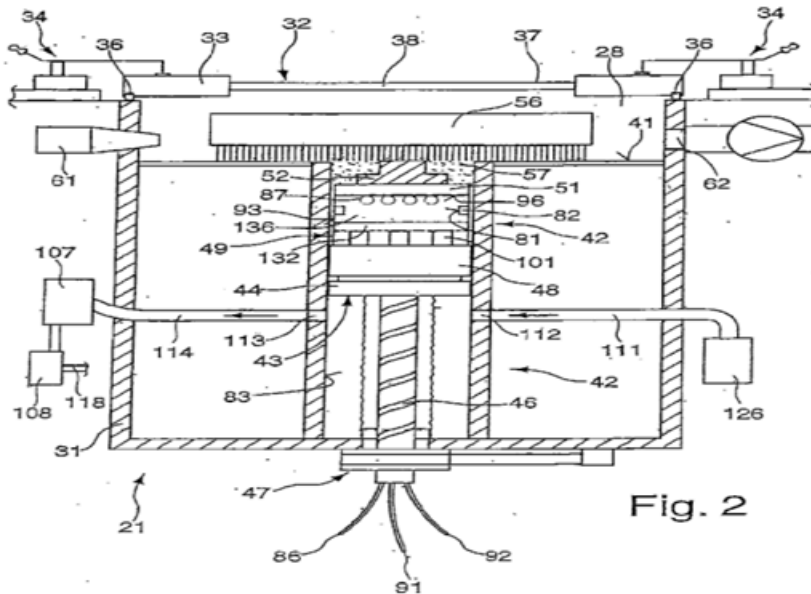

Fig. 2

Relationships with other classification places

Apparatus for treating or handling the raw materials for creating objects or the objects themselves outside of the additive manufacturing apparatus are classified in [B33Y 40/00](#).

B33Y 40/00

Auxiliary operations or equipment, e.g. for material handling

Definition statement

This place covers:

The handling or treating of materials used in an additive manufacturing process, or the subsequent treating or handling of objects produced by an additive manufacturing process. Also covered are ancillary components or process steps not directly involving the additive manufacturing process or apparatus, per se, such as cleaning raw materials used in the additive manufacturing process, or recycling residual material from the manufacturing process.

Illustrative example of subject matter classified in this group:

(US 2013/0075957)

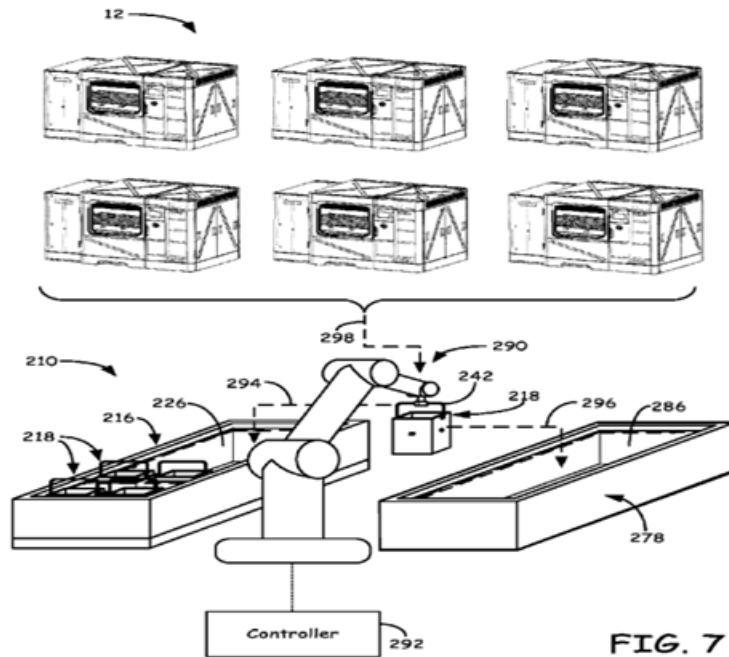

B33Y 50/00

Data acquisition or data processing for additive manufacturing

Definition statement

This place covers:

- Data processing aspects related to an object to be manufactured in an additive manufacturing process, for example, combining together data from different sources to produce composite production data for said object to be made.
- Acquiring, sending, or receiving data that will be used in additive manufacturing, either internal or external to the additive manufacturing apparatus.

Illustrative example of subject matter classified in this group:

(US 2011/0205583)

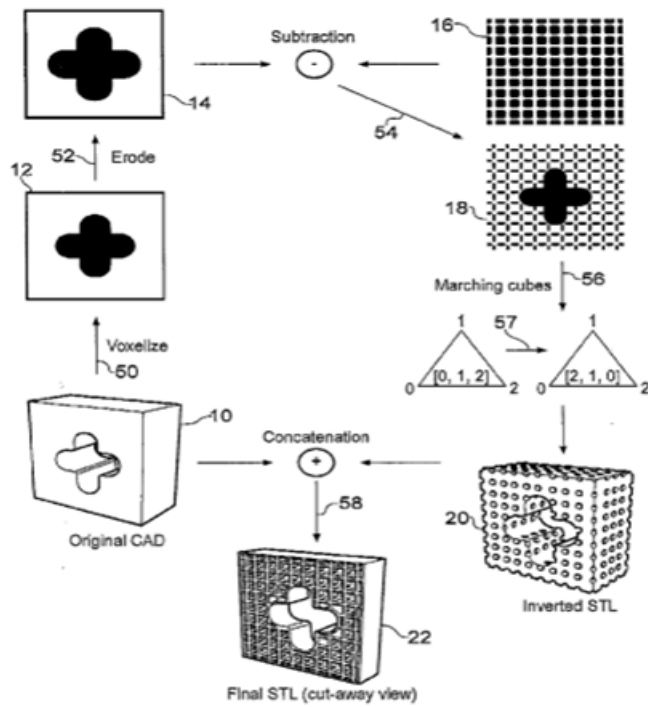

B33Y 50/02

for controlling or regulating additive manufacturing processes

Definition statement

This place covers:

Data processing specially adapted for managing the additive manufacturing process performed by one or more additive manufacturing apparatuses.

Illustrative example of subject matter classified in this group:

(US 2013/0053995)

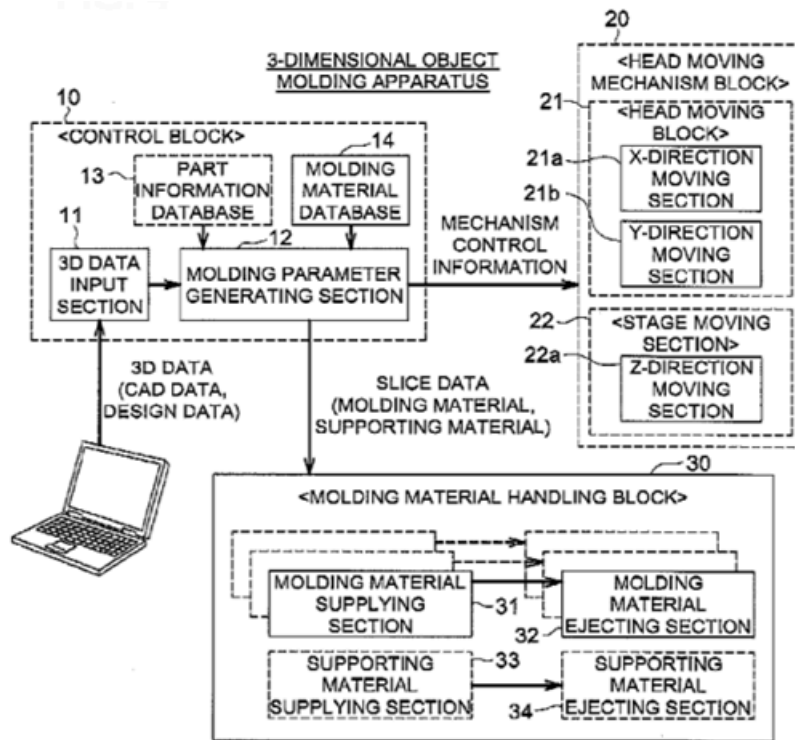

B33Y 70/00

Materials specially adapted for additive manufacturing

Definition statement

This place covers:

Subject matter related to the composition, structure, or other properties of the materials used in an additive manufacturing process to make an object.

Illustrative example of subject matter classified in this group:

(US 2008/0122141)

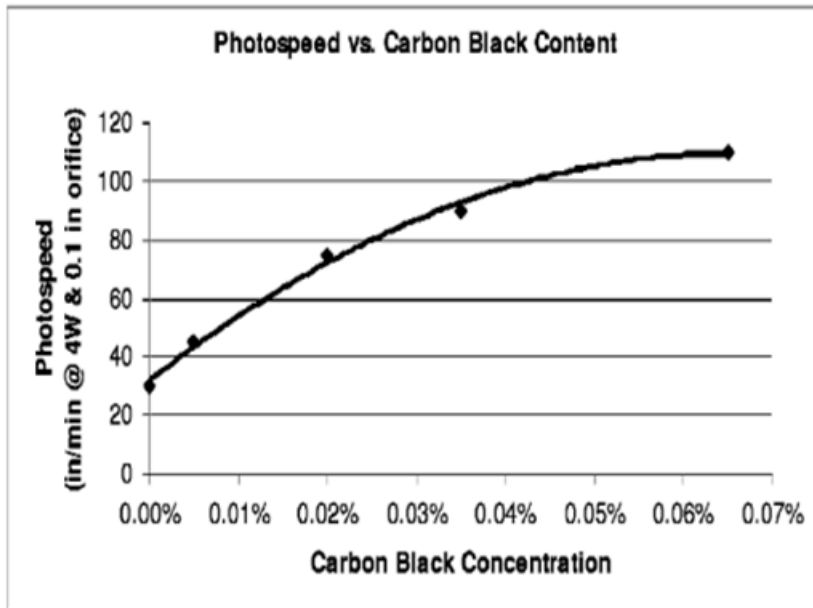

B33Y 80/00

Products made by additive manufacturing

Definition statement

This place covers:

Products obtained by additive manufacturing

Illustrative example of subject matter classified in this group:

(US 2014/0033538)

Fig.1.

