

## B21C

### MANUFACTURE OF METAL SHEETS, WIRE, RODS, TUBES OR PROFILES, OTHERWISE THAN BY ROLLING; AUXILIARY OPERATIONS USED IN CONNECTION WITH METAL-WORKING WITHOUT ESSENTIALLY REMOVING MATERIAL

#### Definition statement

*This place covers:*

The methods and devices for working metal as follows:

Metal drawing (covered by [B21C 1/00](#) - [B21C 19/00](#))

Metal extrusion (covered by [B21C 23/00](#) - [B21C 35/00](#))

Methods for manufacturing metal sheets, bars, wires tubes or the like. (covered by [B21C 37/00](#))

Devices for cleaning metal products adapted for use with machines of this subclass (covered by [B21C 43/00](#))

Separating mandrels from work (covered by [B21C 45/00](#))

Winding-up, coiling, winding-off metal wire or metal band (covered by [B21C 47/00](#))

Devices for temporarily accumulating material (covered by [B21C 49/00](#))

Measuring, gauging, indicating, counting, marking devices adapted for use with subclasses [B21B](#) - [B21F](#) (covered by [B21C 51/00](#))

Other subject-matter concerning the manufacture of metal sheets, wire, rods, tubes or profiles otherwise than by rolling as well as other subject-matter concerning auxiliary operations used in connection with metal-working without essentially removing material (covered by [B21C 99/00](#)).

#### References

##### Limiting references

*This place does not cover:*

Working or processing of sheet metal or metal tubes, rods or profiles	<a href="#">B21D</a>
---	----------------------

##### Informative references

*Attention is drawn to the following places, which may be of interest for search:*

Methods for manufacturing metal sheets, bars, wires tubes or the like by rolling	<a href="#">B21B</a>
Devices for cleaning metal sheet from scale, i.e. descaling, in combination with rolling	<a href="#">B21B 45/00</a>
Making forged or pressed products	<a href="#">B21K</a>
Soldering, welding	<a href="#">B23K</a>
Other working of metal, combined operations	<a href="#">B23P</a>
Transport or storage devices, e.g. conveyors for loading	<a href="#">B65G</a>
Handling thin or filamentary material, e.g. sheets, webs, cables	<a href="#">B65H</a>
Devices for cleaning in general	<a href="#">C08B</a>

## B21C 1/00

### Manufacture of metal sheets, metal wire, metal rods, metal tubes by drawing

#### Definition statement

*This place covers:*

Methods, devices and drives for metal drawing.

Metal drawing consists in reducing the cross-section of a work piece (e.g. reducing the diameter of a metal rod or wire) by forcing it through a die. Metal drawing differs from extrusion by the lower rate of reduction.

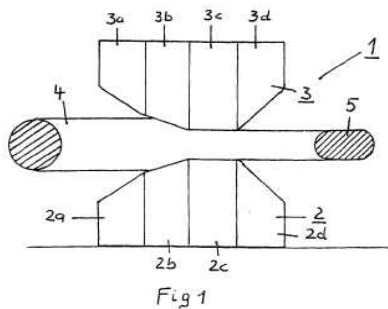

Source:EP1393828

#### References

##### Informative references

*Attention is drawn to the following places, which may be of interest for search:*

Metal drawing tools, dies and mandrels	<a href="#">B21C 3/00</a>
Pointing	<a href="#">B21C 5/00</a>
Cooling, heating or lubricating drawing material	<a href="#">B21C 9/00</a>

## B21C 3/00

### Profiling tools for metal drawing; Combinations of dies and mandrels

#### Definition statement

*This place covers:*

All aspects relating to metal drawing tools (dies, die holders, mandrels).

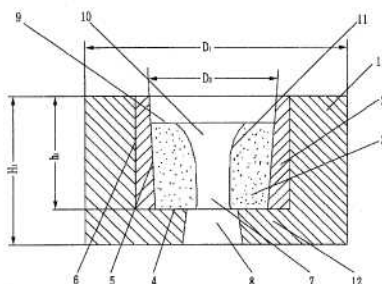

Source: WO2008010614

## References

### Informative references

Attention is drawn to the following places, which may be of interest for search:

Metal drawing machines, methods or drives	<a href="#">B21C 1/00</a>
Pointing	<a href="#">B21C 5/00</a>
Cooling, heating or lubricating drawing material	<a href="#">B21C 9/00</a>

## B21C 5/00

### Pointing; Push-pointing

#### Definition statement

*This place covers:*

Reducing the cross-section of the material's leading end for easing its insertion into the drawing die prior to drawing.

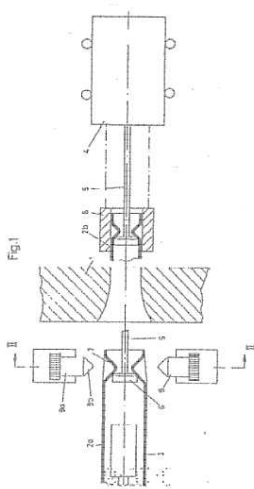

Source: DE3634229

## B21C 9/00

**Cooling, heating or lubricating drawing material ([B21C 3/14](#) takes precedence)**

### Definition statement

*This place covers:*

All aspects of cooling, heating or lubricating the drawing material and/or the drawing devices or dies.

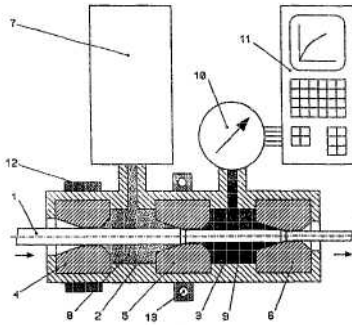

Source: DE19817088

### References

#### Informative references

Attention is drawn to the following places, which may be of interest for search:

Metal drawing machines, methods or drives	<a href="#">B21C 1/00</a>
Metal drawing tools, dies and mandrels	<a href="#">B21C 3/00</a>
Lubricants in general	<a href="#">C10M</a>

## B21C 19/00

**Devices for straightening wire or like work combined with or specially adapted for use in connection with drawing or winding machines or apparatus**

### Definition statement

*This place covers:*

Devices either:

- for straightening wire, wherein the straightening action is realized by using drawing dies, or
- for straightening wire, which devices are used in combination with wire drawing or winding machines (e.g. straightening prior to drawing).

### References

#### Informative references

Attention is drawn to the following places, which may be of interest for search:

Winding, coiling	<a href="#">B21C 47/00</a>
Straightening or restoring form of metal rods, metal tubes, metal profiles, or specific articles made there from.	<a href="#">B21D 3/08</a>
Working of wire by straightening	<a href="#">B21F 1/02</a>

## B21C 23/00

### Extruding metal; Impact extrusion

#### Definition statement

*This place covers:*

Methods and devices for metal extrusion; products obtained by metal extrusion as well as lubrication aspects.

The title refers to impact extrusion. This is however only one specific metal extrusion technique covered by this group.

Metal extrusion consists in forcing solid metal through a suitably shaped orifice using compressive forces. Metal extrusion differs from metal drawing by the higher rate of reduction.

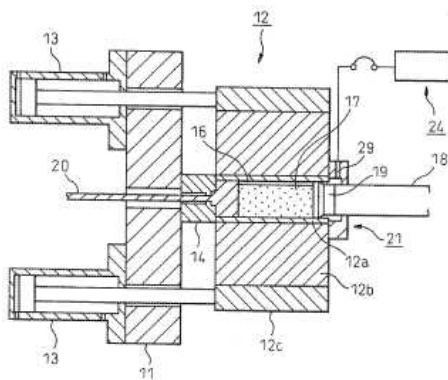

Source: US2007227221

#### References

##### Informative references

Attention is drawn to the following places, which may be of interest for search:

Tools for metal extrusion (i.e. mandrels and dies)	<a href="#">B21C 25/00</a>
Rams, plungers or disks therefore	<a href="#">B21C 26/00</a>
Containers for metal to be extruded	<a href="#">B21C 27/00</a>
Cooling or heating work or parts of the extrusion press	<a href="#">B21C 29/00</a>
Control or measuring devices in relation with extrusion	<a href="#">B21C 31/00</a>
Feeding extrusion presses with metal to be extruded	<a href="#">B21C 33/00</a>
Removing work or waste from extrusion presses; Cleaning	<a href="#">B21C 35/00</a>
Continuous casting	<a href="#">B22D</a>
Extrusion of plastic material	<a href="#">B29C 47/00</a>

## B21C 25/00

### Profiling tools for metal extruding

#### Definition statement

*This place covers:*

Dies and mandrels for metal extrusion, including dies and mandrels for coating work by extrusion or having a section variable during extruding.

The extrusion die and/or mandrel define/s the section through which the billet is forced, thereby defining the cross sectional shape of the extruded product.

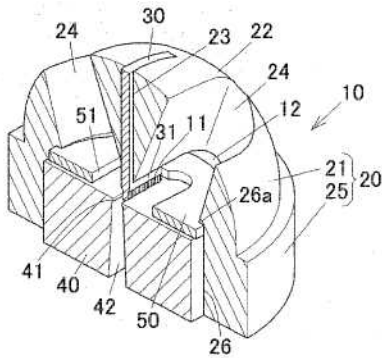

Source: WO2007029888

**References**

**Informative references**

Attention is drawn to the following places, which may be of interest for search:

Extrusion devices and methods	<a href="#">B21C 23/00</a>
Rams, plungers or disks therefore	<a href="#">B21C 26/00</a>
Containers for metal to be extruded	<a href="#">B21C 27/00</a>
Cooling or heating work or parts of the extrusion press	<a href="#">B21C 29/00</a>
Control or measuring devices in relation with extrusion	<a href="#">B21C 31/00</a>
Feeding extrusion presses with metal to be extruded	<a href="#">B21C 33/00</a>
Removing work or waste from extrusion presses; Cleaning	<a href="#">B21C 35/00</a>

**B21C 26/00**

**Rams or plungers; Discs therefor**

**Definition statement**

*This place covers:*

Rams or plungers for metal extrusion; the disks therefore as well as the dummy blocks.

The extrusion ram or plunger is normally the element applying the extrusion pressure to the billet to be extruded.

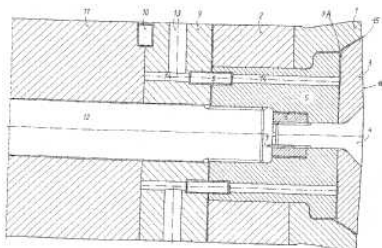

Source: DE10036463

## References

### Informative references

Attention is drawn to the following places, which may be of interest for search:

Extrusion devices and methods	<a href="#">B21C 23/00</a>
Tools for metal extrusion (i.e. mandrels and dies)	<a href="#">B21C 25/00</a>
Containers for metal to be extruded	<a href="#">B21C 27/00</a>
Cooling or heating work or parts of the extrusion press	<a href="#">B21C 29/00</a>
Control or measuring devices in relation with extrusion	<a href="#">B21C 31/00</a>
Feeding extrusion presses with metal to be extruded	<a href="#">B21C 33/00</a>
Removing work or waste from extrusion presses; Cleaning	<a href="#">B21C 35/00</a>

## B21C 27/00

Containers for metal to be extruded ([B21C 29/02](#) takes precedence)

### Definition statement

This place covers:

The container is the element into which the billet is placed and pressurized for extrusion.

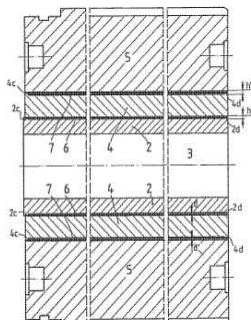

Source: DE3342617

## References

### Limiting references

This place does not cover:

Containers comprising cooling or heating elements	<a href="#">B21C 29/02.</a>
---	-----------------------------

### Informative references

Attention is drawn to the following places, which may be of interest for search:

Extrusion devices and methods	<a href="#">B21C 23/00</a>
Tools for metal extrusion (i.e. mandrels and dies)	<a href="#">B21C 25/00</a>
Rams, plungers or disks therefore	<a href="#">B21C 26/00</a>
Cooling or heating work or parts of the extrusion press	<a href="#">B21C 29/00</a>
Control or measuring devices in relation with extrusion	<a href="#">B21C 31/00</a>
Feeding extrusion presses with metal to be extruded	<a href="#">B21C 33/00</a>

Removing work or waste from extrusion presses; Cleaning	<a href="#">B21C 35/00</a>
---	----------------------------

## B21C 29/00

### Cooling or heating work or parts of the extrusion press; {Gas treatment of work}

#### Definition statement

*This place covers:*

All aspects relating to heating or cooling in combination with metal extrusion.

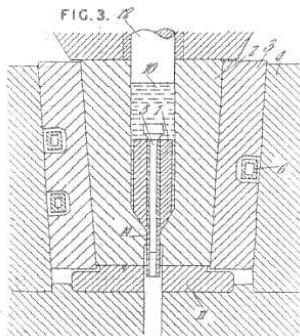

Source: GB1058854

## References

### Informative references

*Attention is drawn to the following places, which may be of interest for search:*

Extrusion devices and methods	<a href="#">B21C 23/00</a>
Tools for metal extrusion (i.e. mandrels and dies)	<a href="#">B21C 25/00</a>
Rams, plungers or disks therefore	<a href="#">B21C 26/00</a>
Containers for metal to be extruded	<a href="#">B21C 27/00</a>
Control or measuring devices in relation with extrusion	<a href="#">B21C 31/00</a>
Feeding extrusion presses with metal to be extruded	<a href="#">B21C 33/00</a>
Removing work or waste from extrusion presses; Cleaning	<a href="#">B21C 35/00</a>



## B21C 31/00

Control devices, e.g. for regulating the pressing speed or temperature of metal ([B21C 25/08](#) takes precedence); Measuring devices, e.g. for temperature of metal, combined with or specially adapted for use in connection with extrusion presses (measuring devices of more general interest within subclass [B21C](#), see group [B21C 51/00](#))

### Definition statement

*This place covers:*

Control devices, e.g. for regulating the pressing speed or temperature of metal; Measuring devices, e.g. for temperature of metal, combined with or specially adapted for use in connection with extrusion presses.

**Fig.1**

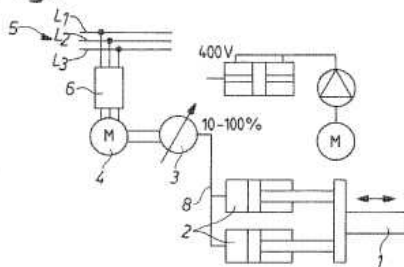

Source: EP2361700

### References

#### Informative references

Attention is drawn to the following places, which may be of interest for search:

Extrusion devices and methods	<a href="#">B21C 23/00</a>
Tools for metal extrusion (i.e. mandrels and dies)	<a href="#">B21C 25/00</a>
Rams, plungers or disks therefore	<a href="#">B21C 26/00</a>
Containers for metal to be extruded	<a href="#">B21C 27/00</a>
Cooling or heating work or parts of the extrusion press	<a href="#">B21C 29/00</a>
Feeding extrusion presses with metal to be extruded	<a href="#">B21C 33/00</a>
Removing work or waste from extrusion presses; Cleaning	<a href="#">B21C 35/00</a>
Measuring devices of more general interest	<a href="#">B21C 51/00</a>

## B21C 33/00

### Feeding extrusion presses with metal to be extruded{; Loading the dummy block}

#### Definition statement

*This place covers:*

All aspects concerning operations or devices upstream of the extrusion press or extrusion process, and specifically linked to it, including e.g. feeding conveyors and grippers used to provide a workpiece to an extrusion press.

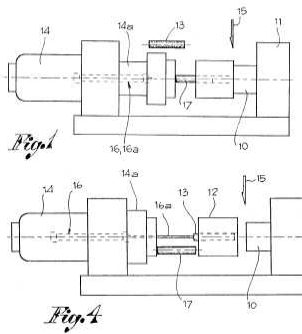

Source: EP0486436

#### References

##### Informative references

Attention is drawn to the following places, which may be of interest for search:

Extrusion devices and methods	<a href="#">B21C 23/00</a>
Tools for metal extrusion (i.e. mandrels and dies)	<a href="#">B21C 25/00</a>
Rams, plungers or disks therefore	<a href="#">B21C 26/00</a>
Containers for metal to be extruded	<a href="#">B21C 27/00</a>
Cooling or heating work or parts of the extrusion press	<a href="#">B21C 29/00</a>
Control or measuring devices in relation with extrusion	<a href="#">B21C 31/00</a>
Removing work or waste from extrusion presses; Cleaning	<a href="#">B21C 35/00</a>

## B21C 35/00

### Removing work or waste from extruding presses; Drawing-off extruded work (in connection with the extruding of bent tubes or rods [B21C 23/12](#)); Cleaning dies, ducts, containers, or mandrels

#### Definition statement

*This place covers:*

All aspects concerning operations or devices downstream of the extrusion press or extrusion process, and specifically linked to it, including e.g.:

- Removing work or waste from extruding presses;
- Drawing off extruded work;
- Cleaning dies, ducts, containers or mandrels.
- Scrapers and scraping knives for cutting-off or removing the waste or for removing sections from the extruded work, e.g. removing a strip to create an open profile.

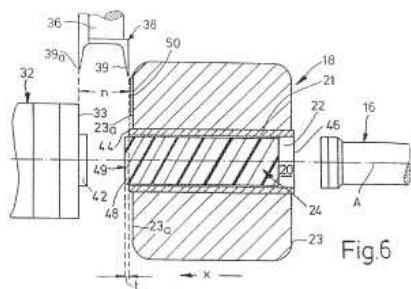

Source: EP0787543

## References

### Informative references

Attention is drawn to the following places, which may be of interest for search:

Extrusion devices and methods	<a href="#">B21C 23/00</a>
Tools for metal extrusion (i.e. mandrels and dies)	<a href="#">B21C 25/00</a>
Rams, plungers or disks therefore	<a href="#">B21C 26/00</a>
Containers for metal to be extruded	<a href="#">B21C 27/00</a>
Cooling or heating work or parts of the extrusion press	<a href="#">B21C 29/00</a>
Control or measuring devices in relation with extrusion	<a href="#">B21C 31/00</a>
Feeding extrusion presses with metal to be extruded	<a href="#">B21C 33/00</a>

## B21C 37/00

Manufacture of metal sheets, bars, wire, tubes or like semi-manufactured products, not otherwise provided for (by rolling [B21B](#); by working or processing semi-finished sheet metal, profiles, tubes, or wire [B21D](#) or [B21F](#); by casting [B22](#); by material-removing machine tools [B23](#); by welding, e.g. cladding or plating [B23K](#); by grinding or polishing [B24](#); by electroforming [C25D 1/00](#); by drawing or extruding, see the relevant groups); Manufacture of tubes of special shape

### Definition statement

*This place covers:*

Processes and devices for the manufacture of:

Metal sheets (covered by [B21C 37/02](#)).

Metal wires (covered by [B21C 37/04](#)).

Metal tubes (covered by [B21C 37/08-B21C 37/14](#)).

Metal tubes of special shape (covered by [B21C 37/15-B21C 37/298](#)).

Finishing tubes, e.g. sizing, burnishing (covered by [B21C 37/30](#)).

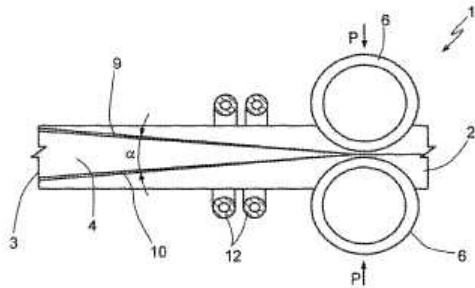

Fig.2

Source: EP1880776

**References**

**Informative references**

Attention is drawn to the following places, which may be of interest for search:

Metal extrusion devices and methods	<a href="#">B21C 23/00</a>
Bending of metal sheet along straight lines	<a href="#">B21D 5/00</a>
Manufacture of metallic fibers	<a href="#">B23P 17/06</a>

**B21C 43/00**

**Devices for cleaning metal products combined with or specially adapted for use with machines or apparatus provided for in this subclass**

**Definition statement**

*This place covers:*

All aspects relating to cleaning metal products, wherein the cleaning action is realized by using machines of [B21C](#) or wherein the cleaning action is used in combination with machines of [B21C](#).

This group includes in particular, cleaning metal products, especially descaling, by metal drawing, or with methods associated to metal drawing or winding processes.

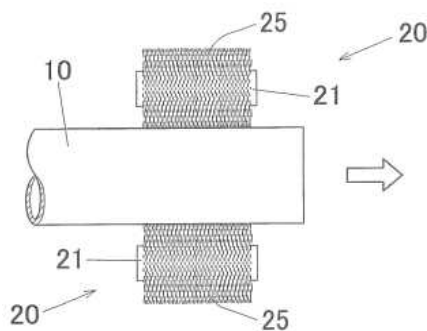

Source: WO2006200502

## B21C 45/00

### Separating mandrels from work or vice versa

#### Definition statement

*This place covers:*

Separation of mandrels from work or vice-versa.

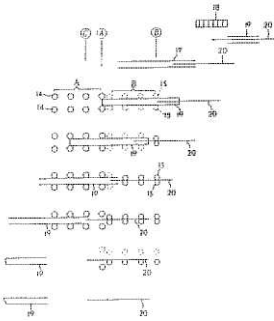

Source: JP61092708

## B21C 47/00

**Winding-up, coiling or winding-off metal wire, metal band or other flexible metal material characterised by features relevant to metal processing only (coiling wire into particular forms [B21F 3/00](#); hot coilers in connection with heat-treatment apparatus [C21D 9/68](#))**

#### Definition statement

*This place covers:*

Methods and devices for coiling (winding) and uncoiling (unwinding) of metal wire, band or similar metal product.

Associated operations, like feeding or guiding the material, transferring coils, joining wire or band ends, treating the material, holding on drums or coil holders.

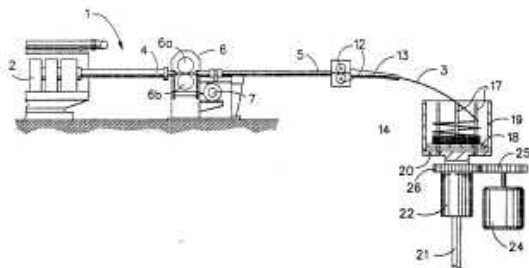

Source: US5170653

## References

### Informative references

Attention is drawn to the following places, which may be of interest for search:

Joining metal sheets	<a href="#">B21B 15/0085</a>
Coiling wire into particular form	<a href="#">B21F 3/00</a>

Unwinding welding material	<a href="#">B23K 9/1333</a>
Furnace coilers, Hot coilers	<a href="#">C21D 9/68</a>
Winding electrical elements	<a href="#">H01F 41/00</a> , <a href="#">H02K 15/00</a>

## B21C 49/00

### Devices for temporarily accumulating material

#### Definition statement

*This place covers:*

Devices for temporarily accumulating metallic material (e.g. metal bands or wires).

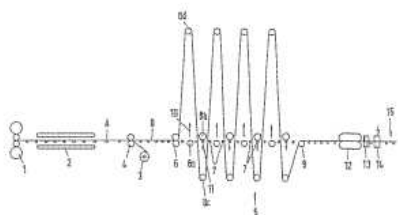

Source: DE4243409

#### References

##### Informative references

Attention is drawn to the following places, which may be of interest for search:

Accumulating rolled material	<a href="#">B21B 41/00</a>
Accumulating material in general	<a href="#">B65H 20/00</a>

## B21C 51/00

**Measuring, gauging, indicating, counting, or marking devices specially adapted for use in the production or manipulation of material in accordance with subclasses [B21B](#) - [B21F](#)**

#### Definition statement

*This place covers:*

Mainly detecting flaws of metal sheets and positioning or marking said flaws.

However, this group has been conceived very generally, which is reflected in its content.

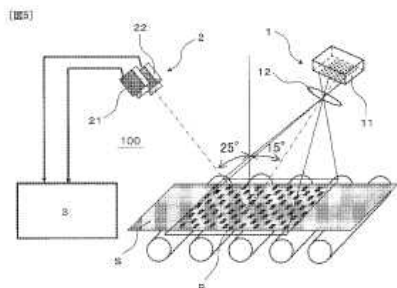

Source: WO2011145168

## References

### *Informative references*

*Attention is drawn to the following places, which may be of interest for search:*

Embossing, marking	<a href="#">B44B</a>
Measuring	<a href="#">G01N</a>

## B21C 99/00

### Subject matter not provided for in other groups of this subclass

#### Definition statement

*This place covers:*

Subject-matter not provided for in other groups of this subclass concerning the manufacture of metal sheets, wire, rods, tubes or profiles otherwise than by rolling

Subject-matter not provided for in other groups of this subclass concerning auxiliary operations used in connection with metal-working without essentially removing material.