

EUROPEAN PATENT OFFICE
U.S. PATENT AND TRADEMARK OFFICE

CPC NOTICE OF CHANGES 926

DATE: AUGUST 1, 2020

PROJECT RP0152

The following classification changes will be effected by this Notice of Changes:

<u>Action</u>	<u>Subclass</u>	<u>Group(s)</u>
SCHEME:		
Symbols Deleted:	A61B	6/0457
Symbols New:	A61B	6/0487
Titles Changed:	A61B	6/00
	A61B	6/03
	A61B	6/037
	A61B	6/0407
	A61B	6/0414
	A61B	6/0421
	A61B	6/0435
	A61B	6/0442
	A61B	6/045
	A61B	6/0464
	A61B	6/0471
	A61B	6/0478
	A61B	6/06
	A61B	6/10
	A61B	6/107
	A61B	6/12
	A61B	6/145
	A61B	6/40
	A61B	6/4007
	A61B	6/4035
	A61B	6/405
	A61B	6/4057
	A61B	6/4064
	A61B	6/42
	A61B	6/4216
	A61B	6/4233
	A61B	6/4241
	A61B	6/425
	A61B	6/44
	A61B	6/4405
	A61B	6/4411
	A61B	6/4429
	A61B	6/4476
	A61B	6/465
	A61B	6/466
	A61B	6/48
	A61B	6/52

CPC NOTICE OF CHANGES 926

DATE: AUGUST 1, 2020

PROJECT RP0152

<u>Action</u>	<u>Subclass</u>	<u>Group(s)</u>
	A61B	6/5217
	A61B	6/5229
	A61B	6/5235
	A61B	6/5241
	A61B	6/5247
	A61B	6/5258
	A61B	6/527
	A61B	6/54
	A61B	6/547
	A61B	6/548
	A61B	6/566
	A61B	6/58
	A61B	6/581
	A61B	6/583
	A61B	6/584
Indents Changed:	A61B	6/0464
	A61B	6/0471
Warnings New:	A61B	6/02
	A61B	6/4283
	A61B	6/4411
	A61B	6/4429
Notes New:	A61B	6/00
DEFINITIONS:		
Definitions Deleted: (no frozen (F) symbol definitions should be deleted)	A61B	6/0457
Definitions New:	A61B	6/0487
Definitions Modified:	A61B	6/00
	A61B	6/02
	A61B	6/022
	A61B	6/025
	A61B	6/027
	A61B	6/03
	A61B	6/032
	A61B	6/037
	A61B	6/04
	A61B	6/06
	A61B	6/12
	A61B	6/14
	A61B	6/40
	A61B	6/4007
	A61B	6/4014

CPC NOTICE OF CHANGES 926

DATE: AUGUST 1, 2020

PROJECT RP0152

<u>Action</u>	<u>Subclass</u>	<u>Group(s)</u>
	A61B	6/4021
	A61B	6/4035
	A61B	6/4057
	A61B	6/4225
	A61B	6/4241
	A61B	6/425
	A61B	6/4258
	A61B	6/4291
	A61B	6/4405
	A61B	6/4411
	A61B	6/4417
	A61B	6/4458
	A61B	6/447
	A61B	6/461
	A61B	6/466
	A61B	6/481
	A61B	6/482
	A61B	6/501
	A61B	6/52
	A61B	6/5205
	A61B	6/5217
	A61B	6/5252
	A61B	6/5258
	A61B	6/527
	A61B	6/541
	A61B	6/545
	A61B	6/547
	A61B	6/548
	A61B	6/566
	A61B	6/581
	A61B	6/583
	A61B	6/585
	A61B	6/587

No other subclasses/groups are impacted by this Notice of Changes.

This Notice of Changes includes the following [Check the ones included]:

1. CLASSIFICATION SCHEME CHANGES

- A. New, Modified or Deleted Group(s)
- B. New, Modified or Deleted Warning(s)
- C. New, Modified or Deleted Note(s)
- D. New, Modified or Deleted Guidance Heading(s)

2. DEFINITIONS

CPC NOTICE OF CHANGES 926

DATE: AUGUST 1, 2020

PROJECT RP0152

- A. New or Modified Definitions (Full definition template)
 - B. Modified or Deleted Definitions (Definitions Quick Fix)
3. REVISION CONCORDANCE LIST (RCL)
 4. CHANGES TO THE CPC-TO-IPC CONCORDANCE LIST (CICL)
 5. CHANGES TO THE CROSS-REFERENCE LIST (CRL)

CPC NOTICE OF CHANGES 926

DATE: AUGUST 1, 2020

PROJECT RP0152

1. CLASSIFICATION SCHEME CHANGES

A. New, Modified or Deleted Group(s)**SUBCLASS A61B- DIAGNOSIS; SURGERY; IDENTIFICATION**

<u>Type*</u>	<u>Symbol</u>	<u>Indent Level Number of dots (e.g. 0, 1, 2)</u>	<u>Title (new or modified)</u> <u>“CPC only” text should normally be enclosed in {curly brackets}**</u>	<u>Transferred to[#]</u>
M	A61B6/00	0	Apparatus for radiation diagnosis, e.g. combined with radiation therapy equipment (instruments measuring radiation intensity for application in the field of nuclear medicine, e.g. in vivo counting, G01T 1/161; apparatus for taking X-ray photographs G03B 42/02)	
C	A61B6/02	1	Devices for diagnosis sequentially in different planes; Stereoscopic radiation diagnosis	A61B6/02, A61B6/4429
M	A61B6/03	2	Computerised tomographs (echo-tomography A61B 8/14)	
M	A61B6/037	3	{Emission tomography}	
M	A61B6/0407	2	{Supports, e.g. tables or beds, for the body or parts of the body}	
M	A61B6/0414	3	{with compression means}	
M	A61B6/0421	3	{with immobilising means}	
M	A61B6/0435	3	{with means for imaging suspended breasts}	
M	A61B6/0442	3	{made of non-metallic materials}	
M	A61B6/045	3	{with heating or cooling means}	
D	A61B6/0457	2		<administrative transfer to A61B6/0487>
M	A61B6/0464	3	{mounted to ceiling}	
M	A61B6/0471	3	{based on an endless-band}	
M	A61B6/0478	2	{Chairs}	
U	A61B6/0485	2	{Inflatable rests for lifting of patients}	
N	A61B6/0487	2	{Motor-assisted positioning}	
M	A61B6/06	1	Diaphragms	
M	A61B6/10	1	Application or adaptation of safety means	
M	A61B6/107	2	{Protection against radiation, e.g. shielding}	
M	A61B6/12	1	Devices for detecting or locating foreign bodies (A61B6/02 takes precedence)	
M	A61B6/145	2	{by intraoral means}	

CPC NOTICE OF CHANGES 926

DATE: AUGUST 1, 2020

PROJECT RP0152

<u>Type*</u>	<u>Symbol</u>	<u>Indent Level Number of dots (e.g. 0, 1, 2)</u>	<u>Title (new or modified) “CPC only” text should normally be enclosed in {curly brackets}**</u>	<u>Transferred to#</u>
M	A61B6/40	1	{ with arrangements for generating radiation specially adapted for radiation diagnosis }	
M	A61B6/4007	2	{ characterised by using a plurality of source units }	
M	A61B6/4035	2	{ the source being combined with a filter or grating }	
M	A61B6/405	2	{ Source units specially adapted to modify characteristics of the beam during the data acquisition process (A61B6/4021, A61B6/4035 take precedence) }	
M	A61B6/4057	2	{ by using radiation sources located in the interior of the body (A61B6/037 takes precedence) }	
M	A61B6/4064	2	{ specially adapted for producing a particular type of beam }	
M	A61B6/42	1	{ with arrangements for detecting radiation specially adapted for radiation diagnosis }	
M	A61B6/4216	3	{ using storage phosphor screens }	
M	A61B6/4233	3	{ using matrix detectors }	
M	A61B6/4241	3	{ using energy resolving detectors, e.g. photon counting }	
M	A61B6/425	3	{ using detectors specially adapted to be used in the interior of the body }	
T	A61B6/4283	2	{ characterised by a detector unit being housed in a cassette }	
M	A61B6/44	1	{ Constructional features of apparatus for radiation diagnosis }	
M	A61B6/4405	2	{ the apparatus being movable or portable, e.g. handheld or mounted on a trolley }	
C	A61B6/4411	2	{ the apparatus being modular (A61B6/4283 takes precedence) }	A61B6/4411, A61B6/4283
T	A61B6/4429	2	{ related to the mounting of source units and detector units }	
M	A61B6/4476	2	{ related to motor-assisted motion of the source unit }	
M	A61B6/465	3	{ adapted to display user selection data, e.g. graphical user interface, icons or menus }	
M	A61B6/466	3	{ adapted to display 3D data }	

CPC NOTICE OF CHANGES 926

DATE: AUGUST 1, 2020

PROJECT RP0152

<u>Type*</u>	<u>Symbol</u>	<u>Indent Level Number of dots (e.g. 0, 1, 2)</u>	<u>Title (new or modified)</u> <u>“CPC only” text should normally be enclosed in {curly brackets}**</u>	<u>Transferred to#</u>
M	A61B6/48	1	{Diagnostic techniques (A61B 6/022, A61B 6/025 A61B 6/032, A61B 6/037 take precedence)}	
M	A61B6/52	1	{Devices using data or image processing specially adapted for radiation diagnosis}	
M	A61B6/5217	3	{extracting a diagnostic or physiological parameter from medical diagnostic data}	
M	A61B6/5229	3	{combining image data of a patient, e.g. combining a functional image with an anatomical image}	
M	A61B6/5235	4	{combining images from the same or different ionising radiation imaging techniques, e.g. PET and CT}	
M	A61B6/5241	5	{combining overlapping images of the same imaging modality, e.g. by stitching}	
M	A61B6/5247	4	{combining images from an ionising-radiation diagnostic technique and a non-ionising radiation diagnostic technique, e.g. X-ray and ultrasound}	
M	A61B6/5258	2	{involving detection or reduction of artifacts or noise}	
M	A61B6/527	4	{using data from a motion artifact sensor}	
M	A61B6/54	1	{Control of apparatus or devices for radiation diagnosis}	
M	A61B6/547	2	{involving tracking of position of the device or parts of the device}	
M	A61B6/548	2	{Remote control of the apparatus or devices}	
M	A61B6/566	2	{involving communication between diagnostic systems}	
M	A61B6/58	1	{Testing, adjusting or calibrating apparatus or devices for radiation diagnosis}	
M	A61B6/581	2	{Remote testing of the apparatus or devices}	
M	A61B6/583	3	{using calibration phantoms}	
M	A61B6/584	4	{determining position of components of the apparatus or device using images of the phantom}	

CPC NOTICE OF CHANGES 926

DATE: AUGUST 1, 2020

PROJECT RP0152

*N = new entries where reclassification into entries is involved; C = entries with modified file scope where reclassification of documents from the entries is involved; Q = new entries which are firstly populated with documents via administrative transfers from deleted (D) entries. Afterwards, the transferred documents into the Q entry will either stay or be moved to more appropriate entries, as determined by intellectual reclassification; T= existing entries with enlarged file scope, which receive documents from C or D entries, e.g. when a limiting reference is removed from the entry title; M = entries with no change to the file scope (no reclassification); D = deleted entries; F = frozen entries will be deleted once reclassification of documents from the entries is completed; U = entries that are unchanged.

NOTES:

- **No { curly brackets } are used for titles in CPC only subclasses, e.g. C12Y, A23Y; 2000 series symbol titles of groups found at the end of schemes (orthogonal codes); or the Y section titles. The { curly brackets } are used for 2000 series symbol titles found interspersed throughout the main trunk schemes (breakdown codes).
- U groups: it is obligatory to display the required “anchor” symbol (U group), i.e. the entry immediately preceding a new group or an array of new groups to be created (in case new groups are not clearly subgroups of C-type groups). Always include the symbol, indent level and title of the U group in the table above.
- All entry types should be included in the scheme changes table above for better understanding of the overall scheme change picture. Symbol, indent level, and title are required for all types.
- “Transferred to” column must be completed for all C, D, F, and Q type entries. F groups will be deleted once reclassification is completed.
- When multiple symbols are included in the “Transferred to” column, avoid using ranges of symbols in order to be as precise as possible.
- For administrative transfer of documents, the following text should be used: “< administrative transfer to XX>”, “<administrative transfer to XX and YY simultaneously>”, or “<administrative transfer to XX, YY, ...and ZZ simultaneously>” when administrative transfer of the same documents is to more than one place.
- Administrative transfer to main trunk groups is assumed to be the source allocation type, unless otherwise indicated.
- Administrative transfer to 2000/Y series groups is assumed to be “additional information”.
- If needed, instructions for allocation type should be indicated within the angle brackets using the abbreviations “ADD” or “INV”: <administrative transfer to XX ADD> , <administrative transfer to XX INV>, or < administrative transfer to XX ADD, YY INV, ... and ZZ ADD simultaneously>.
- In certain situations, the “D” entries of 2000-series or Y-series groups may not require a destination (“Transferred to”) symbol, however it is required to specify “<no transfer>” in the “Transferred to” column for such cases.
- For finalisation projects, the deleted “F” symbols should have <no transfer> in the “Transferred to” column.
- For more details about the types of scheme change, see CPC Guide.

CPC NOTICE OF CHANGES 926

DATE: AUGUST 1, 2020

PROJECT RP0152

B. New, Modified or Deleted Warning(s)

SUBCLASS A61B- DIAGNOSIS; SURGERY; IDENTIFICATION

<u>Type*</u>	<u>Location</u>	<u>Old Warning notice</u>	<u>New/Modified Warning notice</u>
N	A61B6/02		Group A61B6/02 is impacted by reclassification into group A61B6/4429. Groups A61B6/02 and A61B6/4429 should be considered in order to perform a complete search.
N	A61B6/4283		Group A61B6/4283 is incomplete pending reclassification of documents from group A61B6/4411. Groups A61B6/4411 and A61B6/4283 should be considered in order to perform a complete search.
N	A61B6/4411		Group A61B6/4411 is impacted by reclassification into group A61B6/4283. Groups A61B6/4411 and A61B6/4283 should be considered in order to perform a complete search.
N	A61B6/4429		Group A61B6/4429 is incomplete pending reclassification of documents from group A61B6/02. Groups A61B6/02 and A61B6/4429 should be considered in order to perform a complete search.

*N = new warning, M = modified warning, D = deleted warning

NOTE: The "Location" column only requires the symbol PRIOR to the location of the warning. No further directions such as "before" or "after" are required.

CPC NOTICE OF CHANGES 926

DATE: AUGUST 1, 2020

PROJECT RP0152

C. New, Modified or Deleted Note(s)

SUBCLASS A61B - DIAGNOSIS; SURGERY; IDENTIFICATION

<u>Type*</u>	<u>Location</u>	<u>Old Note</u>	<u>New/Modified Note</u>
N	A61B6/00		Note: {In this group the following terms or expressions are used with the meaning indicated: <ul style="list-style-type: none">• “radiation” means ionising radiation, e.g. X rays or gamma rays, and does not cover other forms of radiation, e.g. optical} }

*N = new note, M = modified note, D = deleted note

NOTE: The “Location” column only requires the symbol PRIOR to the location of the note. No further directions such as “before” or “after” are required.

2. A. DEFINITIONS (new)

Insert: The following new Definition

A61B6/0487

Definition statement

This place covers:

Motor controlled patient positioning

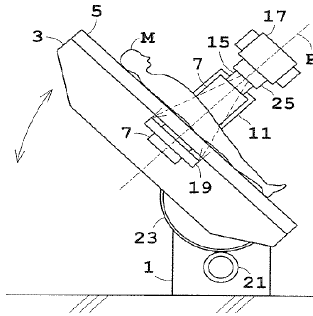

References

Informative references

Attention is drawn to the following places, which may be of interest for search:

Tracking apparatus position	A61B6/547
-----------------------------	-----------

DATE: AUGUST 1, 2020

PROJECT RP0152

2. A DEFINITIONS (modified)

A61B6/00

Definition statement

Replace: The word “equipments” with the word “equipment”.

Relationships with other classification places

Replace: The existing text in the Relationships with other classification places section with the following image and text.

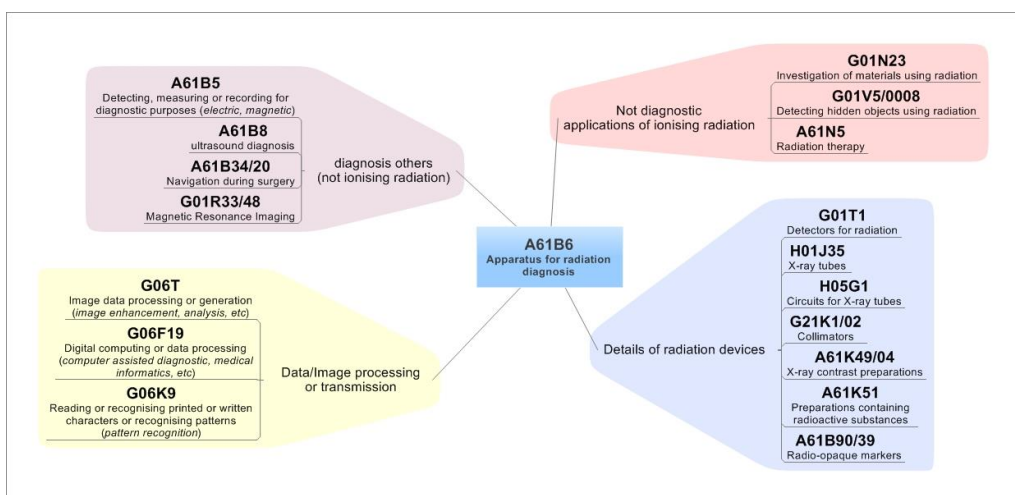

Several subclasses, groups and subgroups provide for the different components or functional aspects constituting the devices for radiation diagnosis. It should be emphasized that documents describing these components should be classified in A61B6/00 only if they disclose a radiation diagnostic device and the link between said components or functional aspects and the radiation diagnostic device or clinical application is not trivial.

As an example, a document describing constructional details of a PET scanner should have the subgroup A61B6/037 and the corresponding class for said constructional details (a subgroup of A61B6/44). A document describing particular details of a radiation detector should be classified in the corresponding group of G01T1/00, even if a clinical application of said detector is mentioned. However, if e.g. details of the arrangement of said detector in a scanner for said particular clinical

DATE: AUGUST 1, 2020

PROJECT RP0152

application are disclosed, then it should also be classified in A61B6/037 and in the corresponding subgroup of A61B6/50.

The same principle applies to other neighbouring fields such as image processing G06T. A document disclosing an algorithm for image enhancement should be classified under the corresponding subclass of G06T, even if the document mentions that the images are X-ray images.

However, if the algorithm requires particular constructional or functional details of the radiation diagnostic device or if there is a non-obvious link to the particular clinical application, then the document should also be classified in the corresponding subgroup of A61B6/00.

On the other hand, classify only in A61B6/00, if there is only a mention of use of an algorithm for image enhancement, but the disclosure deals mainly with details of the radiation diagnostic device.

Devices for radiation diagnosis combined with radiation therapy equipment should be additionally classified in A61N5/00.

References

Limiting references

Replace: The Limiting references table with the following table.

Instruments measuring radiation intensity for application in the field of nuclear medicine, e.g. in vivo counting	G01T1/161
Apparatus for taking X-ray photographs	G03B42/02

Informative references

Replace: The Informative references table with the following table.

CPC NOTICE OF CHANGES 926

DATE: AUGUST 1, 2020

PROJECT RP0152

Diagnosis using magnetic resonance imaging	A61B5/055
Diagnosis using light	A61B5/0059
Diagnosis using the opto-acoustic effect	A61B5/0093
Diagnosis using sonic, infrasonic or ultrasonic waves	A61B8/00
Detectors for X-ray, gamma, etc radiation	G01T1/00
X-ray tubes	H01J35/00
X-ray apparatus involving X-ray tubes; Circuits therefor	H05G1/00
Collimators and grids	G21K1/02
X-ray contrast preparations	A61K49/04
Preparations containing radioactive substances	A61K51/00
Radio-opaque markers	A61B90/39
Image data processing	G06T
Medical informatics	G16H, G16Z 99/00
Navigation during surgery	A61B34/20
Investigation of materials using radiation	G01N23/00
Detecting hidden objects using radiation	G01V5/0008
Radiation therapy	A61N5/00
Nuclear Magnetic Resonance imaging systems	G01R 33/48
X-ray photographic processes	G03C 5/16

Special rules of classification

Delete: Symbol “A61B6/44” from the first table, “Construction-oriented aspects”

Delete: All text and symbols below the “Operation-oriented aspects” table.

Glossary of terms

DATE: AUGUST 1, 2020

PROJECT RP0152

Delete: The word "Medical" from the entry "Medical diagnostic data".

A61B6/02

Special rules of classification

Replace: The existing Special rules of classification section with the text below.

The term "sequential" is used here for historical reasons, meaning that the device can be configured to obtain an image of a plane and subsequently, only by changing the device configuration and without moving the patient, to obtain a different plane. This aspect is not relevant anymore in the current definition, since a cone-beam CT would obtain images of different planes simultaneously but would still be classified under A61B6/032 (a subgroup of A61B6/02).

Acquisition of projections for reconstructing an image is not considered to be a temporal series of images (A61B6/486), since the reconstructed image will be associated to a single time.

A61B6/022

Definition statement

Replace: The existing Definition statement text with the two paragraphs below. Do not delete image.

Acquisition and/or display of two offset images.

This group covers both functional (e.g. stereoscopic imaging technique) and constructional aspects (stereoscopic imaging scanners) of radiation-based stereoscopic imaging.

Delete: The patent number below the image.

A61B6/025

Definition statement

Replace: All of the existing paragraphs and the two images in the Definition statement section with the three paragraphs shown below.

DATE: AUGUST 1, 2020

PROJECT RP0152

Classical geometric tomography is a method of producing an image of a three dimensional object (human body) by moving an x-ray source in an opposing motion (x-ray tube and film housing) during exposure to sharpen the structure images in the focal plane and produce a single film integrated x-ray. The objects in the planes above and below the fulcrum are blurred in proportion to their distance from the plane of focus due to parallax.

Modern tomosynthesis is a technique of using a series of source positions from varying orientations to produce a group of images and with a computer program reconstruct the arbitrary planes into the final clear image.

The subgroup covers both functional (e.g. tomosynthesis imaging technique) and constructional aspects (tomosynthesis scanners) of radiation-based tomosynthesis imaging.

References

Delete: The entire Limiting references section.

Informative references

Insert: The following two new rows in the Informative references table.

Computed tomography	A61B6/032
Reconstruction from projections	G06T11/003

Special rules of classification

Replace: The first paragraph in the Special rules of classification section with the following two paragraphs:

In modern tomosynthesis the sequence of orientations defines an acquisition trajectory which, if relevant, should be classified under A61B6/027.

In case of a circular trajectory of the source and the detector, said rotation is shorter than $180^\circ + \text{fan angle of the beam}$ (acquisition of an incomplete

dataset). If the rotation is longer, then a complete dataset is acquired and the technique is a computerised tomography (see A61B6/032).

A61B6/027

Definition statement

Delete: In the Definition statement section, the patent number that appears below the first image.

[US2003031290]

Replace: In the Definition statement section, the paragraph that appears after the first image in the subgroup with the one below:

Partial isocentric motion with stationary detector in tomosynthesis, A61B6/025, in which the detector stays in one place or is stationary while the x-ray tube rotates around a point of rotation.

Delete: In the Definition statement section, the second image and the text/citation that begins with "Dobbins and Godfrey" shown below:

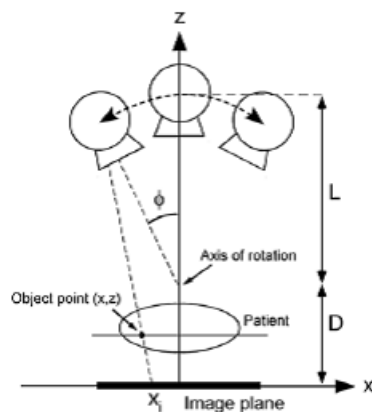

[Dobbins and Godfrey, "Digital x-ray tomosynthesis: current state of the art and clinical potential", Phys. Med. Biol. 48 (2003) R65–R106]B

References

DATE: AUGUST 1, 2020

PROJECT RP0152

Informative referencesInsert: The following new row in the Informative references table.

Trajectory planning for programme-controlled manipulators (e.g. robotic arms)	B25J9/1664
---	------------

Special rules of classificationDelete: The patent number that appears below the image:

[WO2009128063]

A61B6/03**References**Insert: A new Limiting references section as shown below.**Limiting references***This place does not cover:*

Echo-tomography	A61B8/14
-----------------	----------

Informative referencesReplace: The Informative references table with the one below

Optical tomography	A61B5/0073
Diagnosis using magnetic resonance tomography	A61B5/055
Medical informatics	G16H30/00
Reconstruction from projections	G06T11/003
Healthcare informatics	G16H

Special rules of classificationInsert: The following new Special rules of classification section.

CPC NOTICE OF CHANGES 926

DATE: AUGUST 1, 2020

PROJECT RP0152

Computed tomography in radiation diagnosis is basically either transmission tomography (A61B6/032) or emission tomography (A61B6/037), the subgroups of A61B6/03 cover therefore all possible options so that this group is mainly to provide structure in the scheme. Documents disclosing transmission tomography (e.g. CT) or emission tomography (e.g. PET) should be classified in A61B6/032 and A61B6/037, respectively, but not in A61B6/03.

DATE: AUGUST 1, 2020

PROJECT RP0152

A61B6/032

Definition statement

Replace: The first paragraph in the Definition statement with the following two paragraphs:

The source emits a radiation beam from outside the body and the attenuation of the beam is measured by a detector after the beam has traversed the patient's body. This measurement is carried out from different angles and an image (representing the values of the attenuation coefficient of the radiation at every position in space) is reconstructed (computed) from the measurements.

A typical configuration consists of an X-ray source unit emitting a 2D dimensional beam in the form of a fan (fan-beam) and a curved detector (1 line) which rotate around the patient along a circular trajectory to reconstruct (compute) a 2D image (slice) of the patient on the plane of said circular trajectory.

Delete: The patent number below the image.

[US2005254621]

Replace: The word "class" with the word "group" in the fourth paragraph.

The group covers both functional (e.g. computerized tomography) and constructional aspects (computerized tomographs) of transmission tomography imaging.

References

Delete: The entire Limiting references section.

Insert: A new Informative references section.

Informative references

Attention is drawn to the following places, which may be of interest for search:

DATE: AUGUST 1, 2020

PROJECT RP0152

Diagnosis using magnetic resonance tomography	A61B5/055
Optical tomography	A61B5/0073
Tomosynthesis	A61B6/025
Transmission ultrasound tomography	A61B8/15
Reconstruction from projections	G06T11/003

Special rules of classification

Replace: The first paragraph in Special rules of classification with the following two paragraphs:

Transmission tomography as a technique that can be carried out with any device capable of acquiring views (projections) from different angles and can rotate at least 180° + fan angle around the patient. Devices with a more constrained rotational trajectory are not capable of performing tomographic imaging and are restricted to perform tomosynthesis (A61B6/025).

If the device is a CT scanner, it should be classified here (A61B6/032), otherwise said devices are classified according to their constructional features A61B6/44, e.g. C-arm (A61B6/4441), robotic arms (A61B6/4458).

A61B6/037

Definition statement

Replace: The word “classified” with the word “classified” in the second paragraph of the Definition statement as shown below

PET or SPECT scanners are classified under A61B6/037.

Delete: The patent number located below the image.

[US2011309252]

DATE: AUGUST 1, 2020

PROJECT RP0152

References

Delete: The entire Limiting references section.

Informative references

Insert: The following new rows in the Informative references table.

Measuring radiation	G01T1/00
Radiation detection aspects of PET imaging	G01T1/2985
Radiation detection aspects of SPECT imaging	G01T1/1642

Special rules of classification

Replace: In the second sentence of the first paragraph of the Special rules section “intra-operative” with “intraoperative” and “classified” with “classified” so that the paragraph appears as follows:

This class covers devices for emission tomography, reconstruction of 2D images (slices) or 3D images (sets of slices). Other devices such as intraoperative gamma cameras should be classified under A61B6/4258.

A61B6/04

References

Insert: The following new Limiting references section.

Limiting references

This place does not cover:

Operating tables	A61G13/00
Operating chairs	A61G15/00

DATE: AUGUST 1, 2020

PROJECT RP0152

Informative references

Delete: From the Informative references table, the row shown below.

Operating tables or chairs	A61G13/00, A61G 5/00
----------------------------	-------------------------

Insert: The following new row in the Informative references table.

Radiation therapy	A61N5/10
-------------------	----------

A61B6/0457

Delete: The entire Definition for A61B 6/0457.

A61B6/06

Definition statement

Replace: The Definition statement with the following two new paragraphs.

Diaphragms specially adapted for particular diagnostic applications, e.g. tomography.

Devices adapted to modify the spatial confinement of the cross-section of the radiation beam, e.g. collimators, situated between the source unit and the patient.

Delete: The patent number located below the image.

[US2011206185]

References

Delete: The entire Limiting references section.

DATE: AUGUST 1, 2020

PROJECT RP0152

Informative references

Insert: The following new Informative references section.

Informative references

Attention is drawn to the following places, which may be of interest for search:

Source combined with filter or grating	A61B6/4035
Detector combined with grid or grating	A61B6/4291
Multi-leaf collimators for intensity modulated radiation therapy	A61N5/1045
Diaphragms/collimators per se	G21K1/02

Special rules of classification

Replace: The Special rules text with the following reformatted text (no changes to the text).

Rules for classifying other devices situated on the beam path, used to modify properties of the beam:

Filters (A61B6/4035): modify a property of the beam but not its spatial confinement, e.g. the spectrum, or the intensity distribution.

Gratings: cause diffraction and are used mainly for phase measurements.

Grids: arrangements of blades situated along the detector pixels and used to block scattered radiation.

Grids and gratings are classified depending on their position:

A61B6/4035 when situated between source unit and patient,

A61B6/4291 when situated between patient and detector.

DATE: AUGUST 1, 2020

PROJECT RP0152

A61B6/12

Definition statement

Delete: From the Definition statement section, the image and citation text below the image.

References

Limiting references

Replace: The existing two rows in the Limiting references table with the new row below.

Devices for diagnosis sequentially in different planes; Stereoscopic radiation diagnosis	A61B6/02
--	----------

Informative references

Insert: The following two new rows in the existing Informative references table.

Surgical navigation systems	A61B34/20
Radio-opaque markers	A61B90/39

Special rules of classification

Delete: In the Special rules of classification paragraph, all of the parentheses around the reference symbols, so the paragraph looks like the one below.

This class covers the use of radiation diagnostic devices to determine the position of a surgical instrument during an operation, e.g. using a C-arm [A61B6/4441](#) for performing fluoroscopy [A61B6/487](#). However, it does not cover path calculations and guiding of said instruments [A61B34/20](#).

A61B6/14

References

Limiting references

DATE: AUGUST 1, 2020

PROJECT RP0152

Delete: The entire Limiting references section including the two images and image citations below the table.

Informative references

Insert: The following two new rows.

Radiation diagnosis of bone	A61B6/505
Dentistry per se	A61C1/00 - A61C19/00

Special rules of classification

Replace: The text in the Special rules of classification section with the text below.

Due to their rotation capabilities needed to acquire panoramic images of the teeth, devices for panoramic radiography are often adapted to acquire projection data and generate computed tomographic images or tomosynthesis. In that case, they should be also classified under A61B6/032 or A61B6/025, respectively.

If the device combines panoramic radiography and other imaging techniques, it might have different detectors for each imaging technique and it should be classified under A61B6/4266.

A61B6/40

Definition statement

Delete: In the second paragraph of the Definition statement section, the parentheses around the symbol A61B6/4057.

Insert: The following new paragraph as the last paragraph in the Definition statement section.

NOTE: radioactive tracers are not considered to be contrast agents but sources of radiation in the sense of A61B6/40.

Delete: Both images and the image citations that appear in the Definition statement section.

Special rules of classification

DATE: AUGUST 1, 2020

PROJECT RP0152

Delete: The parentheses around the symbols in the first paragraph of the Special rules of classification section so that the paragraph looks like the one below.

Typically involves the generation of a radiation beam having a particular spatial configuration A61B6/4007, A61B6/4035, A61B6/4064, movement A61B6/4021, A61B6/4057, intensity A61B6/405 or spectrum A61B6/4035.

A61B6/4007

Definition statement

Insert: The new Definition statement section shown below.

Definition statement

This place covers:

A combination of a cathode and a dedicated anode is considered to be a single source unit. In cathode-anode based source units, multiple source units have therefore multiple cathode-anode pairs.

Delete: Both images from the Definition statement

A61B6/4014

Definition statement

Delete: The patent number located below the image in the Definition statement section.

[DE102008049049]

References

Delete: The entire Limiting references section.

Informative references

Insert: The following new row in the Informative references table.

Devices for radiation diagnosis using a plurality of detector units	A61B6/4266
---	------------

DATE: AUGUST 1, 2020

PROJECT RP0152

Special rules of classification

Replace: In the second paragraph of the Special rules of classification section the existing text: “DETECTORS THEY SHOULD NOT BE CLASSIFIED UNDER” with the following revised text.

detectors they should not be classified under

A61B6/4021

Definition statement

Replace: The existing Definition statement with the two paragraphs shown below.

Modification of focal spot position on the anode or between multiple anodes be it in static imaging or in imaging modalities where source unit and detector unit perform data acquisition while following a certain trajectory (swing focus, spring focus, alternating focus, flying focus).

This subgroup covers not only active control of the movement of the focal spot, but also analysis and correction of fluctuations of the position of the focal spot on the anode.

Delete: The images and the image citation in the existing Definition statement section.

References

Limiting references

Delete: The entire Limiting references section.

Informative references

Insert: The following new row in the Informative references table

Radiation devices characterised by the use of a certain acquisition trajectory	A61B6/027
--	-----------

DATE: AUGUST 1, 2020

PROJECT RP0152

Special rules of classification

Insert: The following new Special rules of classification section, including text and image, as shown below.

If modifying the position of the focal spot implies generating a beam of different energy, the device should be classified also under A61B6/482.

See A61B6/4007 for the definition of single/multiple sources.

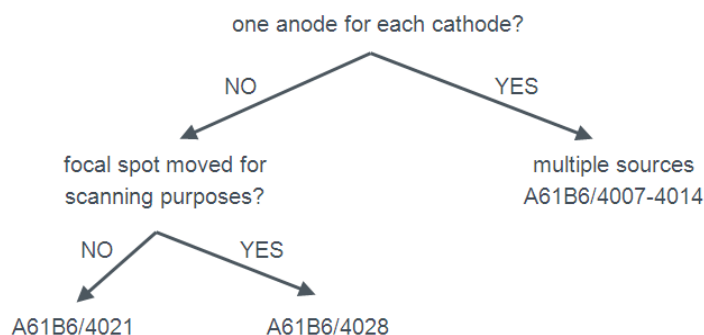

A61B6/4035

Definition statement

Delete: The patent number below the image.

References

Delete: The entire Limiting references section and table.

Informative references

Insert: The following three new rows in the Informative references table.

Collimators for radiation diagnosis devices	A61B6/06
Detector combined with grid or grating	A61B6/4291
X-ray filters per se	G21K1/10

DATE: AUGUST 1, 2020

PROJECT RP0152

A61B6/4057

Definition statement

Delete: The patent number located below the image.

[WO 2005/058129]

References

Limiting References

Replace: In the Limiting references table, the existing row “Capsule endoscopes” with the following new row.

Emission tomography (PET/SPECT)	A61B6/037
---------------------------------	-----------

Informative references

Replace: In the Informative references table, the row “Emission tomography (PET/SPECT) A61B 6/037” with the following new row.

Capsule endoscopes	A61B1/041
--------------------	-----------

Special rules of classification

Replace: The existing text in the Special rules of classification with the text below.

A document disclosing a diagnostic application of PET or SPECT scanner A61B6/037 does not need to be classified also under A61B6/4057 to cover the radioactive tracer aspect since this is implicit in the A61B6/037 code. Only in the case that the document discloses particular technical properties of said tracer that solve a technical problem (e.g. specific tracer injection protocol, combination of tracers, tracer carried to a specific organ by a capsule before release) should the document be classified here.

Applications of intraoperative gamma cameras to detect rests of tumours labelled with a radioactive tracer should get the codes A61B6/4057 and A61B6/4258.

DATE: AUGUST 1, 2020

PROJECT RP0152

A61B6/4225**Definition statement**Delete: The patent number below the image.

[WO2005006257]

ReferencesDelete: The entire Limiting references section.**Informative references**Insert: The following new row in the Informative references table.

Image intensifiers per se	H04N5/32
---------------------------	----------

A61B6/4241**References**Delete: The entire Limiting references section.**Informative references**Insert: The following new rows in the Informative references table.

Multiple energy imaging as an imaging technique	A61B6/482
Detectors for nuclear medicine	G01T1/16, G01T1/29

Special rules of classificationDelete: In the Special rules of classification section, all of the parentheses around the symbols in the two paragraphs, so they look as follows.

Typically combined with the combination of radiation data acquired at different energies to extract a particular diagnostic information
A61B6/482.

DATE: AUGUST 1, 2020

PROJECT RP0152

Multiple energy in radiation diagnostics is typically used to produce enhanced angiographic images A61B6/504 combined with a contrast agent A61B6/481 or for the diagnosis of bone A61B6/505.

A61B6/425**Definition statement**

Delete: The following patent number located below the image.

[WO2005058129]

References

Delete: The entire Limiting references section.

Informative references

Insert: The following two new rows in the Informative references table.

Capsule endoscopes	A61B1/041
Diagnosis using light using a probe introduced into the body	A61B5/0084

Insert: The following new Special rules of classification section.

Special rules of classification

Applications of intraoperative gamma cameras to be introduced in to the body to detect rests of tumours labelled with a radioactive tracer should get the codes A61B6/4057 (for the tracer), A61B6/425 and A61B6/4258.

A61B6/4258**References****Limiting references**

Replace: The existing Limiting references row with the new row below.

Emission tomography	A61B6/037
---------------------	-----------

DATE: AUGUST 1, 2020

PROJECT RP0152

Informative references

Replace: In the Informative references table, the existing row “Emission tomography A61B 6/037” with the following new row.

Detecting radiation	G01T1/00
---------------------	----------

Special rules of classification

Delete: In the Special rules of classification section, the parentheses around the symbol: A61B6/037.

A61B6/4291**Definition statement**

Delete: In the Definition statement section, the patent number below the image.

[US2011274252]

References

Delete: The entire existing Limiting references section.

Informative references

Insert: The following new rows in the Informative references table.

Collimators for radiation diagnosis devices	A61B6/06
Source combined with filter or grating	A61B6/4035
Reduction of scatter by image processing in devices for radiation diagnosis	A61B6/5282
Anti-scatter grids	G21K1/02

DATE: AUGUST 1, 2020

PROJECT RP0152

A61B6/4405**Definition statement**

Delete: In the Definition statement section, the patent number below the image.

[US20100296632]

References**Informative references**

Replace: The existing symbol in the Informative references table

Ultrasound diagnostic devices mounted on a trolley	A61B6/4405
--	------------

with the following new symbol.

Ultrasound diagnostic devices mounted on a trolley	A61B8/4405
--	------------

Replace: The existing text in the following reference

With anti-collision devices or braking systems	A61B6/102 - A61B 6/105
--	------------------------

with the following reference.

Radiation diagnosis devices with anti-collision devices	A61B6/102 - A61B 6/105
---	------------------------

Insert: The following new reference row into the Informative reference table.

Mobile robots	B25J5/00
---------------	----------

DATE: AUGUST 1, 2020

PROJECT RP0152

A61B6/4411

Definition statement

Delete: In the Definition statement section, the patent number located below the image.

[EP2382922]

Insert: The following new Limiting references section.

References

Limiting references

Detector units housed in a cassette	A61B6/4283
-------------------------------------	------------

A61B6/4417

Definition statement

Replace: In the Definition statement, the existing phrase: “relates to X-ray imaging” at the end of the paragraph with the phrase shown below.

using ionising radiation

Delete: In the Definition statement section, the patent number located below the image.

[US2011297834]

Limiting References

Delete: The entire Limiting references section.

DATE: AUGUST 1, 2020

PROJECT RP0152

Informative referencesInsert: The following new row in the Informative references table.

Post-acquisition processing for combination of images from different modalities	A61B6/5229 - A61B6/5247
---	-------------------------

Special rules of classificationReplace: The existing Special rules of classification with the text shown below.

This class covers all details concerning constructional aspects to combine different diagnostic modalities in one device.

(Ionising) radiation - (ionising) radiation: e.g. PET/CT

(Ionising) radiation - other type of diagnostics: e.g. CT/ultrasound A61B8/00, X-ray/optical A61B5/0059, CT/MRI A61B5/055, G01R33/48, etc.

This class does not cover the combination of images coming from the different modalities per se, said combination should be classified under A61B6/5229 and its subgroups, which specify whether the diagnostic modalities are both B6 modalities or B6 and another modality.

A61B6/4458**Definition statement**Delete: The patent number below the image.

[US 2005/0234327]

Insert: The following new Informative references section.**References****Informative references**

Attention is drawn to the following places, which may be of interest for search:

Details concerning robots	B25J
---------------------------	------

DATE: AUGUST 1, 2020

PROJECT RP0152

Insert: The following new Special rules of classification section.

Special rules of classification

A robotic arm is considered to be constituted by a base and a series of segments connected by joints (at least two links and two joints) and has at least 3 degrees of freedom. Typically each joint has a motor that allows the movement of the arm. An arm which is merely telescopic is not considered to be a robotic arm.

The robotic arm must be used to support at least part of the radiation diagnostic device, not e.g. only a radiotherapy source.

A61B6/447

Definition statement

Replace: In the Definition statement section, the existing image labelled "Fig. 6" and the patent number: [US20090040333] under the image with the following new image shown below.

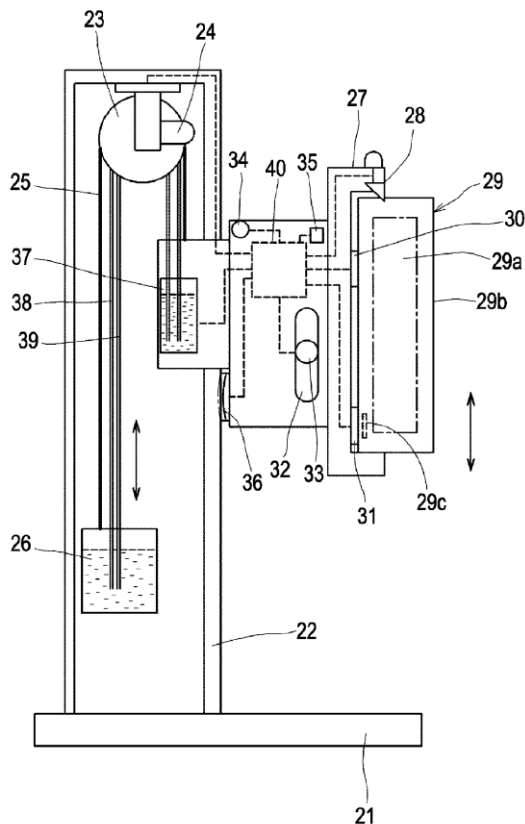

DATE: AUGUST 1, 2020

PROJECT RP0152

A61B6/461

Definition statement

Replace: The existing Definition statement with the statement below.

Displays with special properties not covered elsewhere in A61B6/00.

Special rules of classification

Replace: The existing Special rules of classification text with the text below.

Touch screens should be classified here and as special input means under A61B6/467.

A61B6/466

References

Delete: The entire existing Limiting references section.

Informative references

Insert: The following new row in the existing Informative references table,

3D image rendering per se	G06T15/00
---------------------------	-----------

A61B6/481

Definition statement

Delete: The existing image and the citation “[wikipedia]” under the image.

References

Delete: The entire existing Limiting references section.

DATE: AUGUST 1, 2020

PROJECT RP0152

Informative references

Insert: The following four new rows in the existing Informative references table.

Radiation diagnostic with radioactive tracers	A61B6/4057
Diagnosis of blood vessels	A61B6/504
Diagnosis of hemodynamic parameters	A61B6/507
X-ray contrast preparations	A61K49/04

A61B6/482**References**

Delete: The entire existing Limiting references section.

Informative references

Insert: The following three new rows in the Informative references table.

Source unit with multiple anodes	A61B6/4021
Source unit combined with a filter	A61B6/4035
Energy resolving detectors for radiation diagnosis	A61B6/4241

Special rules of classification

Replace: The entire existing Special rules of classification section with the text shown below.

Radiation diagnostic devices based on multiple energy imaging should be classified under A61B6/482 and additionally according to the technique used to acquire the data at different energy levels, for example:

- A source with several anodes for producing beams with different energy A61B6/4021.
- One beam with a certain energy spectrum which is filtered after leaving the source unit A61B6/4035.

DATE: AUGUST 1, 2020

PROJECT RP0152

- One beam with a certain energy spectrum which is separated into several energy bands at the detector A61B6/4241.
- A dual source-detector scanner with source units emitting radiation beams of different energies A61B6/4014 and A61B6/4266.

Multiple energy imaging is typically used for examining bone A61B6/505 or with contrast agents A61B6/481, where two energy bands, one above and one under the K-edge of the contrast material are used to enhance the effect of the contrast agent in angiography A61B6/504.

Delete: The existing image located below the Special rules of classification paragraphs.

A61B6/501

Definition statement

Delete: The entire Definition statement section including the image and citation.

References

Informative references

Insert: The following new row in the Informative references table.

Use of CT scans for customised prostheses	A61F2002/30948
---	----------------

A61B6/52

References

Delete: The entire Limiting references section.

Insert: The following new Informative references section.

References

Informative references

Attention is drawn to the following places, which may be of interest for search:

Signal processing of physiological signals	A61B5/72
Data/image processing in ultrasound diagnostics	A61B8/52
Image processing per se	G06T

DATE: AUGUST 1, 2020

PROJECT RP0152

Image analysis per se	G06T7/00
Image reconstruction from projection	G06T11/003

Special rules of classification

Delete: From the Special rules of classification section, both the existing image and the link [<http://scien.stanford...image008.jpg>] located below the image.

A61B6/5205

Definition statement

Replace: The text in the existing Definition statement with the text shown below.

Pre-processing of data output from the sensor requiring pre-processing to be used for diagnostic purposes, e.g. sinogram filtering, combination of detector rows, columns or reconstruction of CT images from X-ray projections.

Delete: In the Definition statement section, the image located below the existing paragraph.

References

Delete: The entire Limiting references section.

Informative references

Insert: The following new Informative references section.

References

Informative references

Attention is drawn to the following places, which may be of interest for search:

Detectors calibration	A61B6/585
Processing of raw ultrasound data	A61B8/5207
Image reconstruction from projection	G06T11/003

DATE: AUGUST 1, 2020

PROJECT RP0152

A61B6/5217**References**Delete: The existing Limiting references section.Insert: The following new Informative references section.**References*****Informative references***

Attention is drawn to the following places, which may be of interest for search:

Extracting a diagnostic/physiological parameter from ultrasound diagnostic data	A61B8/5223
Algorithms for biomedical image analysis	G06T7/0012
Segmentation algorithms	G06T7/10
ICT specially adapted for medical diagnosis, medical simulation or medical data mining	G16H 50/00

A61B6/5252**Definition statement**Delete: The patent number “[US2011200169]” located under the image.Insert: The following new Special rules of classification section.**Special rules of classification**

This subgroup concerns removing objects of known origin from the diagnostic images, it does not concern removing artifacts per se (i.e. unpredictable features determined by heat, dust, light), which should be classified under A61B6/5258. Typical examples are removing the patient bed from a CT image or the anti-scatter grid from a radiograph (the artifact caused is of known geometry and has the shape of the grid, so it is considered as removing the grid and not an artifact), nor does it concern removal of body tissues such as bones or anatomic parts such as blood vessels.

DATE: AUGUST 1, 2020

PROJECT RP0152

A61B6/5258

References

Delete: The existing Limiting references section.

Informative references

Insert: The following new Informative references section.

References

Informative references

Attention is drawn to the following places, which may be of interest for search:

Algorithms for image enhancement	G06T5/00
----------------------------------	----------

Special_rules of classification

Replace: The text in the existing Special rules of classification paragraph with the text below.

Applies to reduction of artifacts inherent to the imaging technique (e.g. beam hardening in CT) or reduction of noise, but not to the removal of objects from the image (A61B6/5252).

A61B6/527

References

Delete: The entire existing Limiting references section.

Informative references

Insert: The following three new rows in the existing Informative references table.

Motion derived by measuring table sag	A61B6/5276
Retrospective matching to a physiological signal	A61B6/5288
Acquisition triggered by a physiological signal	A61B6/541

DATE: AUGUST 1, 2020

PROJECT RP0152

A61B6/541

Definition statement

Delete: The existing image in the Definition statement section.

References

Delete: The entire Limiting references section.

Informative references

Insert: The following new row in the existing Informative references table.

Retrospective matching to a physiological signal	A61B6/5288
--	------------

A61B6/545

Definition statement

Delete: The patent number "US2010232573" below image.

References

Delete: The entire Limiting references section.

Insert: The following new Informative references section.

References

Informative references

Attention is drawn to the following places, which may be of interest for search:

Control of exposure during data acquisition in radiation diagnostic devices	A61B6/542
---	-----------

DATE: AUGUST 1, 2020

PROJECT RP0152

A61B6/547**Definition statement**

Delete: In the Definition statement section, the existing patent number “[DE102010020782]” located below the image.

References

Delete: The entire existing Limiting references section.

Insert: The following new Informative references section.

References**Informative references**

Attention is drawn to the following places, which may be of interest for search:

Locating a surgical device in the body with a radiation diagnostic device	A61B6/12
phantoms for determining position of parts of the device	A61B6/584
Surgical navigation systems	A61B34/20

Special rules of classification

Replace: The Special rules of classification paragraph with the following.

This class does not cover tracking the position of a surgical device A61B6/12 or guiding a surgical device A61B34/20.

A61B6/548**References**

Delete: The entire existing Limiting references section.

Insert: The following new Informative references section.

References**Informative references**

DATE: AUGUST 1, 2020

PROJECT RP0152

Attention is drawn to the following places, which may be of interest for search:

Transmission of radiation diagnosis data via a network	A61B6/56
Transmission of radiation diagnosis images via a network	A61B6/563

Special rules of classification

Delete: In the Special rules of classification section, the patent number located below image.

[US2011073769]

Replace: All of the text in the existing Special rules of classification section with the text shown below (do not delete the existing image).

This class covers any kind of remote control, either of the diagnostic device itself or of devices, which are directly related to acquisition of diagnostic data. Typically remote control is carried out through a data network and involves transmission of data A61B6/56 or image data A61B6/563, but the concept is to be interpreted broadly, covering e.g. also a cable with a controller to be used in the same room. It is important however that there is **a technical effect associated with the distance to the device**.

- If there is a link between the remote controlled device and the data acquisition, then the subgroup A61B6/548 should be given, even if what is remote controlled is e.g. an injector.
- This class also covers voice control.

Relationship between A61B6/548 and A61B6/581: A61B6/548 relates to control of data acquisition for diagnostic purposes (e.g. remote configuration) while A61B6/581 relates to checking malfunctioning or adjusting the device itself (e.g. remote calibration or fault detection).

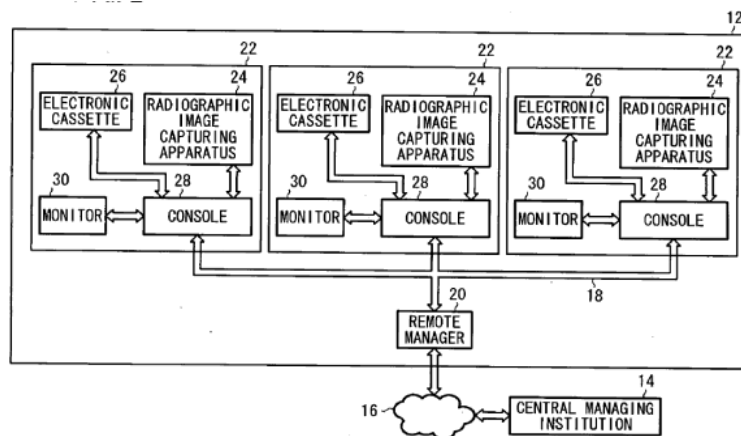

DATE: AUGUST 1, 2020

PROJECT RP0152

A61B6/566

Definition statement

Delete: In the Definition statement section, the patent number located below the image.

[US2011317809]

Special rules of classification

Insert: The following new Special rules of classification section.

Special rules of classification

Transfer of data between parts of diagnostic system are classified under A61B6/56.

A61B6/581

Definition statement

Delete: In the Definition statement section, only the patent number located below the image.

[US2011121969]

Special rules of classification

Insert: The following text as the new second paragraph in the existing Special rules of classification section.

Relationship between A61B6/548 and A61B6/581: A61B6/548 relates to control of data acquisition for diagnostic purposes (e.g. remote configuration) while A61B6/581 relates to checking malfunctioning or adjusting the device itself (e.g. remote calibration or fault detection).

DATE: AUGUST 1, 2020

PROJECT RP0152

A61B6/583Insert: The following new Informative references section.**References****Informative references***Attention is drawn to the following places, which may be of interest for search:*

Models for medical purposes	G09B23/28
-----------------------------	-----------

Special rules of classificationDelete: The parentheses from around symbol (A61B6/4441), so symbol looks as follows.

A61B6/4441

A61B6/585**References****Informative references**Insert: The following new row in the Informative references table.

Calibration techniques for radiation measuring devices	G01T7/005
--	-----------

A61B6/587**References**Delete: The entire Limiting references section.**Informative references**Insert: The following three new rows in the existing Informative references table.

Radiation diagnostic devices comprising source and detector units movable relative to each other	A61B6/4452
--	------------

CPC NOTICE OF CHANGES 926

DATE: AUGUST 1, 2020

PROJECT RP0152

Calibration in radiation diagnostic devices	A61B6/582
Calibration using phantoms to determine position of parts of a device	A61B6/584

CPC NOTICE OF CHANGES 926

DATE: AUGUST 1, 2020

PROJECT RP0152

3. REVISION CONCORDANCE LIST (RCL)

<u>Type*</u>	<u>From CPC Symbol (existing)</u>	<u>To CPC Symbol(s)</u>
C	A61B 6/02	A61B 6/02, A61B 6/4429
D	A61B 6/0457	<administrative transfer to A61B 6/0487>
C	A61B 6/4411	A61B 6/4411, A61B 6/4283

* C = entries with modified file scope where reclassification of documents from the entries is involved; Q = new entries which are firstly populated with documents via administrative transfers from deleted (D) entries. Afterwards, the transferred documents into the Q entry will either stay or be moved to more appropriate entries, as determined by intellectual reclassification; D = deleted entries; F = frozen entries will be deleted once reclassification of documents from the entries is completed.

NOTES:

- Only C, D, F, and Q type entries are included in the table above.
- When multiple symbols are included in the “To” column, do not use ranges of symbols.
- For administrative transfer of documents, the following text should be used: “< administrative transfer to XX>”, “<administrative transfer to XX and YY simultaneously>”, or “<administrative transfer to XX, YY, ...and ZZ simultaneously>” when administrative transfer of the same documents is to more than one place.
- Administrative transfer to main trunk groups is assumed to be the source allocation type, unless otherwise indicated.
- Administrative transfer to 2000/Y series groups is assumed to be “additional information”.
- If needed, instructions for allocation type should be indicated within the angle brackets using the abbreviations “ADD” or “INV”: <administrative transfer to XX ADD>, <administrative transfer to XX INV>, or < administrative transfer to XX ADD, YY INV, ... and ZZ ADD simultaneously>.
- In certain situations, the “D” entries of 2000-series or Y-series groups may not require a destination (“To”) symbol, however it is required to specify “<no transfer>” in the “To” column for such cases.
- RCL is not needed for finalisation projects.

CPC NOTICE OF CHANGES 926

DATE: AUGUST 1, 2020

PROJECT RP0152

4. CHANGES TO THE CPC-TO-IPC CONCORDANCE LIST (CICL)

<u>CPC</u>	<u>IPC</u>	<u>Action*</u>
A61B 6/0457		DELETE
A61B 6/0487	A61B 6/04	NEW

*Action column:

- For an (N) or (Q) entry, provide an IPC symbol and complete the Action column with “NEW.”
- For an existing CPC main trunk entry or indexing entry where the existing IPC symbol needs to be changed, provide an updated IPC symbol and complete the Action column with “UPDATED.”
- For a (D) CPC entry or indexing entry complete the Action column with “DELETE.” IPC symbol does not need to be included in the IPC column.
- For an (N) 2000 series CPC entry which is positioned within the main trunk scheme (breakdown code) provide an IPC symbol and complete the action column with “NEW”.
- For an (N) 2000 series CPC entry positioned at the end of the CPC scheme (orthogonal code), with no IPC equivalent, complete the IPC column with “CPCONLY” and complete the action column with “NEW”.

NOTES:

- F symbols are not included in the CICL table above.
- T and M symbols are not included in the CICL table above unless a change to the existing IPC is desired.