

UNITED STATES PATENT AND TRADEMARK OFFICE

BEFORE THE PATENT TRIAL AND APPEAL BOARD

MICROSOFT CORPORATION
Petitioner

v.

PROXYCONN, INC.
Patent Owner

Case IPR2012-00026 (TLG)
Patent 6,757,717 B1

Before SALLY C. MEDLEY, SCOTT R. BOALICK, and THOMAS L.
GIANNETTI, *Administrative Patent Judges*.

GIANNETTI, *Administrative Patent Judge*.

DECISION ON REQUEST FOR INTER PARTES REVIEW

I. BACKGROUND

Petitioner Microsoft Corporation requests inter partes review of claims 1, 3, 10-12, 14, and 22-24 of US Patent 6,757,717 B1 pursuant to 35 U.S.C. §§ 311 et seq. The Patent Owner, ProxyConn Inc., has waived its right to file a preliminary response under 37 C.F.R. § 42.107(b). Paper No. 15. We have jurisdiction under 35 U.S.C. § 314.

The standard for instituting an inter partes review is set forth in 35 U.S.C. § 314(a) which provides as follows:

THRESHOLD -- The Director may not authorize an inter partes review to be instituted unless the Director determines that the information presented in the petition filed under section 311 and any response filed under section 313 shows that there is a reasonable likelihood that the petitioner would prevail with respect to at least 1 of the claims challenged in the petition.

Petitioner challenges claims 1, 3, 10-12, 14, and 22-24 as anticipated (35 U.S.C. § 102) and obvious (35 U.S.C. § 103). Pet. 3. We grant the petition as to claims 1, 3, 10, and 22-24 and deny the petition as to claims 11, 12, and 14.

A. The '717 Patent (EX1002)

The invention of the '717 patent is a system for data access in a packet switched network. '717 patent Abstract. The system has a sender/computer including an operating unit, a first memory, a permanent storage memory, and a processor. The system also has a remote receiver/computer including an operating unit, a first memory, a permanent storage memory, and a processor. The sender/computer and receiver/computer communicate through the network. *Id.*

The sender/computer further includes a device for calculating digital digests on data; the receiver/computer further includes a network cache memory and a device for calculating digital digests on data in the network cache memory; and the receiver/computer and/or the sender/computer includes a device for comparison between digital digests. *Id.*

As described in the Petition, the '717 patent provides a way to reduce the amount of redundant data transmitted over a network. Pet. 4. The algorithm of the invention checks for the identity between two sets of data by comparing respective digital fingerprints of that data. *Id.* As described in the Summary of the Invention:

If a sender/computer in the network is required to send data to another receiver/computer, and the receiver/computer has data with the same digital digest as that of the data to be sent, it can be assumed with sufficient probability for most practical applications that the receiver/computer has data which is exactly the same as the data being sent. Then, the receiver/computer can use the data immediately without its actual transfer through the network. In the present invention, this idea is used in a variety of ways.

'717 patent col. 2, ll. 16-24.

The patent discloses several embodiments. In one, a sender/computer required to send data to a receiver computer initially sends a digital digest of the data. If the receiver/computer already has data with the same digital digest, it uses this data as if it were actually transmitted from the sender/computer. '717 patent col. 2, ll. 26-31. This embodiment is illustrated in Figs. 5-7. Fig. 5 is reproduced below:

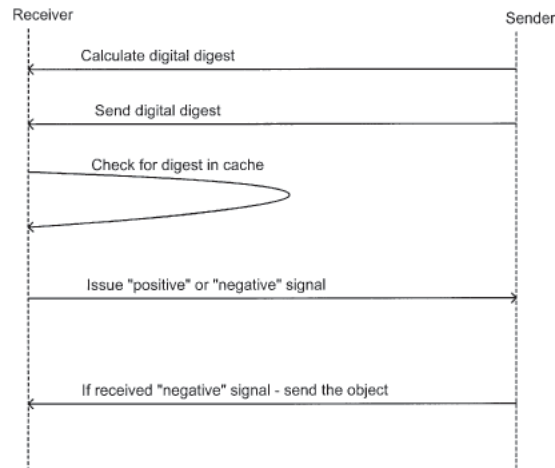

FIG. 5

Fig. 5 is a schematic representation illustrating the interaction between a sender/computer and a receiver/computer according to the teachings of one embodiment of the '717 patent. Col. 5, ll. 49-51. In this embodiment, the receiver/computer receives a digital digest from a sender/computer and searches its network cache memory for data with the same digest. If the receiver/computer finds such data, it uses that data as if the data were received from the sender/computer and issues a positive indication signal to the sender/computer. Otherwise it sends a negative indication signal to the sender/computer. Col. 7, ll. 50-60.

In another embodiment auxiliary digital digests for other data objects can be sent together with the principal digest. If the receiver/computer cannot find data having the principal digest, it searches for data with one of the auxiliary digests. If such data is found, the sender/computer is required to send only the difference between the requested data object and the data object corresponding to the auxiliary digest. '717 patent col. 2, ll. 31-37. The expression in the specification "difference between the first data or data object and the second data or data object"

means any bit sequence that enables the restoration of the first data, given the second data, the bit sequence, and the method employed in calculating the difference. *Id.* ll. 37-41. This embodiment is illustrated in Figs. 8-10. Fig. 8 is reproduced below:

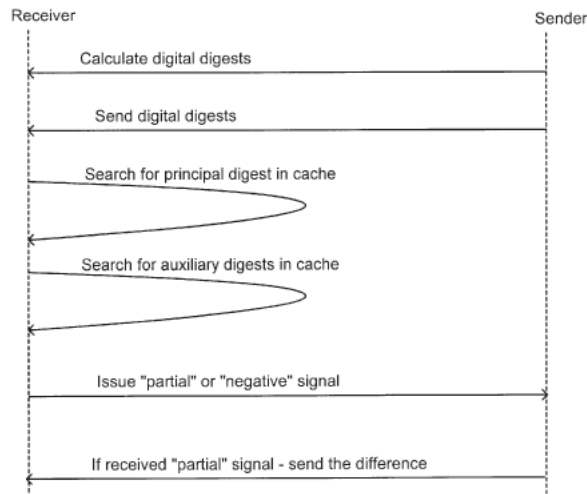

FIG. 8

Fig. 8 is a schematic representation illustrating the interaction between a sender/computer and a receiver/computer according to the teachings of another embodiment of the invention. '717 patent col. 5, ll. 59-61. In this embodiment the sender/computer sends the principal and auxiliary (e.g., of a previous version of the data requested) digests to the receiver/computer. Upon receiving a message with these digital digests from the sender/computer, the receiver/computer searches its network cache memory for data having the same principal digest. If such data is found, the receiver/computer uses the data as if the data were received from the sender/computer and issues a positive indication signal to the sender/computer. Otherwise, the receiver/computer searches its network cache memory for data with the auxiliary digests. If it finds data with a digital digest substantially equal to one

of the auxiliary digests, it issues a partial indication signal to the sender/computer, along with a reference to the digest. Otherwise it issues a negative indication signal to the sender/computer. *Id.* col. 8, ll. 11-39.

B. Prior Art References

Petitioner relies on the following prior art:

1. Perlman US Patent 5,742,820 (EX1003)
2. Yohe US Patent 5,835,943 (EX1005)
3. Santos “Increasing Effective Link Bandwidth by Suppressing Replicated Data,” Proceedings of the USENIX Annual Technical Conference (NO 98), June 1998 (EX1004)
4. Baber US Patent 6,279,041 B1 (EX1017)

1. Perlman (EX1003)

Petitioner contends that Perlman anticipates all challenged claims. Pet. 3. Perlman discloses a mechanism for synchronizing the contents of a database stored on the nodes of a computer network to ensure that those contents are consistent. Perlman Abstract. A database identifier generated by a node of the computer network is distributed to other receiving nodes coupled to the network. The database identifier uniquely represents the contents of the distributing node’s database. The receiving nodes compare this unique identifier with their own generated database identifiers to determine if the identifiers and thus their associated databases are consistent and synchronized. *Id.* The database identifiers preferably are generated from a cryptographic message digest algorithm configured to transform the data identifying the contents of the database into a unique fixed

length digest "signature" whose contents are substantially less than those of the identifying data. *Id.* col. 4, ll. 13-18.

Accordingly, transmission of the database identifier in lieu of identifying all items in the database optimizes both the use of computational resources within the receiving routers and bandwidth on the network. Perlman col. 4, ll. 19-21. Each receiving router initially calculates an identifier based on the contents of its database, and then compares the calculated identifier with the database identifier received from the designated router. A receiving router whose calculated database identifier conforms to the received database identifier needs only store the latter identifier. If the calculated identifier is different, the receiving router may request the data identifying all items in the database to resolve any differences. Significantly the designated router transmits the actual database content information only in response to a change in the database or a request from another router. *Id.* ll. 24-34.

2. *Yohe (EX1005)*

Petitioner contends that Yohe anticipates all challenged claims except claim 24. Pet. 3. Yohe is directed to an apparatus for increasing data access in a network which includes a file server computer with a permanent storage memory, and a cache verifying computer operably connected to the file server computer in a manner to form a network for rapidly transferred data. Yohe Abstract. The cache verifying computer has an operating system, a first memory, and a processor with means for performing an operation on data stored in the permanent storage memory on the file server computer to produce a signature of the data characteristic of one of a file and directory. *Id.* It also includes a remote client computer having an operating system, a first memory, a cache memory, and a

processor with means for performing an operation on data stored in the cache memory to produce a signature of the data, and a communication server operably connected to the remote client computer, the cache verifying computer, and file server computer. Comparators are operably associated with the cache verifying computer and remote client computer for comparing the signatures of data with one another to determine whether the data signature of the remote client is valid.

Id. Also see Yohe col. 2, ll. 41-61.

The performance gains in Yohe are realized by storing a copy of the data in the permanent storage memory of the remote client computer and verifying the stored copy to be current when it is subsequently retrieved. Yohe col. 4, ll. 31-37. This is illustrated in Yohe Fig. 15, blocks 722 and 723. In those blocks the signature of the requested data is compared to the signature retrieved (block 722) and if they match the data object retrieved from the cache is returned (block 723). *Id.* col. 8, ll. 5-13.

3. Santos (EX1004)

Petitioner contends that Santos anticipates claims 1, 3, 11-12, 14, and 22. Pet. 3. Santos describes compression architecture that suppresses replicated data to increase bandwidth in a packet switched environment such as the Internet. Santos 2. The bandwidth savings is achieved by transmitting repeated data as a short dictionary token, using caches of recently-seen data at both ends of the link to maintain the dictionary and encode and decode the tokens. *Id.* at 5. The approach of Santos is based on the insight that the “fingerprint” of a data segment is an inexpensive name for the data itself, both in terms of space and time. *Id.* Santos uses the MD5 hash algorithm for his implementation but states that other “fingerprints” could be used. *Id.* Figure 4 of Santos follows:

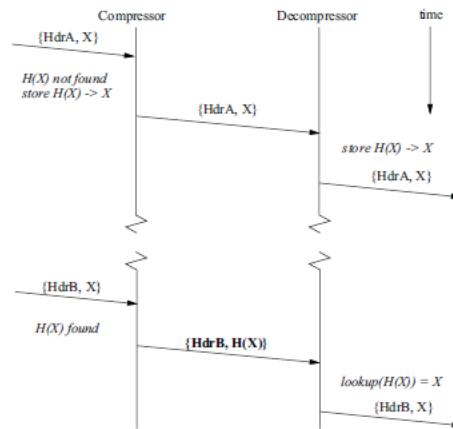

Figure 4: Compression protocol

Fig. 4 of Santos shows message exchange sequence from a sender (compressor) to a receiver (decompressor). Santos 7. The upper portion of the figure illustrates the sequence of events when the compressor receives a packet having header HdrA whose fingerprint H(X) is not in the cache. The lower portion of the figure illustrates the sequence of events occurring when the compressor receives a packet having header HdrB and a fingerprint H(X) that is found in the cache. *Id.* at 7-8. In the first case the compressor stores packet contents X in its cache, indexed by its fingerprint H(X), and forwards the header and contents across the link. In the second case the compressor sends the header and fingerprint, thus achieving a savings in bandwidth. *Id.* at 8.

4. Baber (EX1017)

Petitioner contends that Baber anticipates all claims. Pet. 3. While analyzing Baber itself (*id.* at 29-31), Petitioner does not include Baber in its claim

charts “mapping” the challenged claims to the prior art. *See* EX1001.¹ Nor does Petitioner apply these claims to Baber elsewhere in the Petition or in the supporting materials submitted. Our rules require that a petition must include a “full statement of the reasons for the relief requested, including a detailed explanation of the significance of the evidence...” 37 C.F.R. § 42.22(a)(2). Moreover, “[t]he petition must specify where each element of the claim is found in the prior art patents or publications relied upon” 37 C.F.R. § 42.104(b)(4). Thus while claim charts are not mandatory, some analysis of the challenged claims in relation to the prior art is necessary to meet Petitioner’s burden under 35 U.S.C. § 314(a) and to comply with our rules regarding required content of a petition. *See infra*. Accordingly we conclude that the requirements for instituting inter partes review are not met as to Baber.

II. ILLUSTRATIVE CLAIMS

The following claims illustrate the claimed subject matter:

1. A system for data access in a packet-switched network, comprising:
 - a sender/computer including an operating unit, a first memory, a permanent storage memory and a processor and a remote receiver/computer including an operating unit, a first memory, a permanent storage memory and a processor, said sender/computer and said receiver/computer communicating through said network;
 - said sender computer further including means for creating digital digests on data;

¹ EX1001 appears as Document 4 in the Patent Review and Processing System (“PRPS”).

said receiver/computer further including a network cache memory and means for creating digital digests on data in said network cache memory; and

said receiver/computer including means for comparison between digital digests.

11. A method performed by a sender/computer in a packet-switched network for increasing data access, said sender/computer including an operating unit, a first memory, a permanent storage memory and a processor and said sender/computer being operative to transmit data to a receiver/computer, the method comprising the steps of:

creating and transmitting a digital digest of said data from said sender/computer to said receiver/computer;

receiving a response signal from the receiver/computer at said sender/computer, said response signal containing a positive, partial or negative indication signal for said digital digest, and

if a negative indication signal is received, transmitting said data from said sender/computer to said receiver/computer.

22. A method for increased data access performed by a receiver/computer in a packet-switched network, said receiver/computer including an operating unit, a first memory, a permanent storage memory, a processor and a network cache memory, said method comprising the steps of:

receiving a message containing a digital digest from said network; searching for data with the same digital digest in said network cache memory,

if data having the same digital digest as the digital digest received is not uncovered, forming a negative indication signal and transmitting it back through said network; and

creating a digital digest for data received from said network cache memory.

III. CLAIM CONSTRUCTION

Consistent with the statute and the legislative history of the AIA, the Board will interpret claims using the broadest reasonable construction. *See* Office Patent Trial Practice Guide, 77 Fed. Reg. 48756, 48766 (Aug. 14, 2012); 37 CFR § 100(b). There is a “heavy presumption” that a claim term carries its ordinary and customary meaning. *CCS Fitness, Inc. v. Brunswick Corp.*, 288 F.3d 1359, 1366 (Fed. Cir. 2002). However, as further explained by the Federal Circuit: “[T]he claim term will not receive its ordinary meaning if the patentee acted as his own lexicographer and clearly set forth a definition of the disputed claim term in either the specification or prosecution history.” *Id.* (citation omitted).

As a necessary step in our analysis for determining whether to institute a trial, we make the following claim constructions.

A. Data/Data Object

Patent Owner has acted as its own lexicographer and has defined “data” or “data object” as “a file or range of octets in a file, a range of frames in a video stream or RAM-based range of octets, a transport level network packet, or the like.” Col. 2, ll. 5-8. Petitioner does not challenge this definition. Pet. 10. We therefore adopt this construction.

B. Difference

Patent Owner has acted as its own lexicographer and has defined “difference” in the expression “difference between a first data or data object and a second data or data object” as any bit sequence that enables restoration of the first data, given the second data, the bit sequence, and the method employed in

calculating the difference. Col. 2, ll. 38-42. We adopt this definition, which is unchallenged by Petitioner.

C. Digital Digest

Patent Owner has acted as its own lexicographer and has defined the term “digital digest” as “a fixed-size binary value calculated from arbitrary-size binary data in such a way that it depends only on the contents of the data and the low probability that two different data or objects have the same digital digest.” Col. 2, ll. 9-13. The patent further defines the term “digital digest” as referring to the known MD5 algorithm, but states that other algorithms may be used. For example, a digital digest may be calculated according to the CRC algorithm, or by applying the CRC algorithm to different subsets or different recordings of data, or by consecutively applying CRC and MD5. Col. 6, ll. 24-36.

Petitioner challenges this definition. Pet. 10-11. According to Petitioner, the '717 patent “contradicts” itself by asserting that a digital digest has a similarity check property. Pet. 10. Petitioner contends that neither MD5 nor CRC produces a digest with such a property. *Id.* But Petitioner’s citations to the '717 patent specification do not refer to a “similarity check.” Instead they refer to text using the terms “difference,” which is defined in the specification (*see supra*) and “substantially identical,” which does not appear in the challenged claims. Recognizing a patentee’s right to be his or her own lexicographer, we decline Petitioner’s invitation to further define “digital digest” beyond the definition provided in the '717 patent.

D. Negative Indication Signal

Petitioner's proposed definition of "negative indication signal" includes the absence of a signal. Pet. 13. The '717 patent states that "absence of the indication signal from the receiver/computer for a predefined period of time may be considered by the sender/computer as a negative indication signal..." Col. 8, ll. 41-43. We therefore adopt Petitioner's construction for the term.

E. Positive, partial, or negative indication signals

Contrary to Petitioner, we construe this term as requiring the issuance of all three alternative signals as required. Our reasoning is set forth infra, in our analysis of claims 11, 12, and 14.

F. Sender/computer, Receiver/computer

We construe these terms as a computer that sends or receives data, respectively. We agree with Petitioner that a sender/computer can include multiple devices and that it encompasses intermediaries. See Pet. 15.

G. Operating Unit

We do not interpret this term as a means plus function limitation under 35 U.S.C. § 112 ¶ 6 as suggested by Petitioner. See Pet. 16. We furthermore find no support for, and therefore do not adopt, Petitioner's proposed construction of "anything found in a computer—other than the recited processor and memories--that is used in its operation." *Id.* at 16-18. The '717 patent specification does not require the recited memories and processor to be separate from the operating unit, as in Petitioner's proposed definition. The term "operating unit" is not defined in

the '717 patent. We therefore conclude that plain meaning should apply to this term.²

H. Means for Creating Digital Digests

We agree that this is a means plus function limitation but disagree with Petitioner that the '717 patent discloses no “counterpart.” Pet.17. *See* discussion of the MD5 and CRC algorithms *supra*.

I. Network Cache Memory

We disagree with Petitioner’s construction. Pet. 19. As Petitioner acknowledges that the '717 patent does not “explain” this term (*id.*), we apply it in accordance with its plain meaning.

J. Means for Comparison between Digital Digests

We agree with Petitioner that this is a means plus function element. Pet. 21. We disagree that the '717 patent discloses no “counterpart.” *Id.* *See* comparison means 54 shown in Fig. 4 and described at col.7, ll.33-36 of the '717 patent. The sufficiency of this disclosure under 35 U.S.C. § 112 ¶ 6 is not before us in this proceeding (*see* 35 U.S.C. § 311(b) limiting inter partes review to a ground that could be raised under 35 U.S.C. § 102 or 103). We note, however, that no

² By “plain meaning” we refer to the ordinary and customary meaning the term would have to a person of ordinary skill in the art. Such terms have been held to require no construction. *E.g.*, *Biotec Biologische Naturverpackungen GmbH & Co. KG v. Biocorp, Inc.*, 249 F.3d 1341, 1349 (Fed. Cir. 2001) (finding no error in non-construction of “melting”); *Mentor H/S, Inc. v. Med. Device Alliance, Inc.*, 244 F.3d 1365, 1380 (Fed. Cir. 2001) (finding no error in court’s refusal to construe “irrigating” and “frictional heat”).

algorithm or other structure is linked by the '717 patent specification to the above comparison means. *See, e.g., Noah Systems, Inc. v. Intuit Inc.*, 675 F.3d 1302, 1311 (Fed. Cir. 2012). Recently, in *Ergo Licensing, LLC v. CareFusion 303, Inc.*, 673 F.3d 1361, 1364-65 (Fed. Cir. 2012), the Federal Circuit confirmed that there is a “narrow exception” to the requirement that an algorithm be disclosed when the claimed function can be achieved by any general purpose computer without special programming. *Also see In re Katz Interactive Call Processing Litigation*, 639 F.3d 1303, 1316 (Fed. Cir. 2011), cited approvingly in *Ergo*, where the Court held that absent a possible narrower construction, the functions “processing,” “receiving,” and “storing” were within the exception and were construed to be coextensive with the structure disclosed, i.e., a general purpose computer. Consequently, absent a possible narrower construction from Patent Owner, we conclude that the recitation of “means for comparison” in the '717 patent claims likewise falls within this narrow exception. Our construction of this term, determined by 35 U.S.C. § 112 ¶ 6, is therefore any general purpose computer. We note that this is somewhat broader than Petitioner’s proposed construction: “any device capable of comparing ‘digital digests.’” Pet. 21.

K. Means for Storing Digital Digests

We disagree with Petitioner that there is no “counterpart” for this means plus function element. Pet. 21-22. *See* Fig. 4 showing receiver/computer 46 and sender/computer 42. Our construction of this term is determined by 35 U.S.C. § 112 ¶ 6 in accordance with the discussion of comparison means, *supra*, and therefore we do not adopt Petitioner’s construction.

L. Plain Meaning

We adopt Petitioner's suggestion to apply the remaining terms in accordance with their plain meaning. We discuss *infra* Petitioner's contention that certain of these terms are entitled to "no patentable weight."

IV. ANALYSIS

A. Claims 1 and 3

These claims are directed to the '717 patent Fig. 5 embodiment discussed *supra*. Claim 1 follows:

1. A system for data access in a packet-switched network, comprising:
 - a sender/computer including an operating unit, a first memory, a permanent storage memory and a processor and a remote receiver/computer including an operating unit, a first memory, a permanent storage memory and a processor, said sender/computer and said receiver/computer communicating through said network;
 - said sender computer further including means for creating digital digests on data;
 - said receiver/computer further including a network cache memory and means for creating digital digests on data in said network cache memory;
 - and
 - said receiver/computer including means for comparison between digital digests.

Petitioner's analysis of these claims in relation to Perlman, Yohe, and Santos appears in Appendix A to the Petition (EX1001) at pages 2-11. As Patent Owner has waived filing a preliminary response, we therefore review Petitioner's proposed grounds to determine whether the Petitioner has met the threshold standard of 35 U.S.C. § 314(a), namely, "that the information presented in the

petition ... shows that there is a reasonable likelihood that the petitioner would prevail with respect to at least 1 of the claims challenged in the petition.”

1. *Anticipation 35 U.S.C. § 102*

“A claim is anticipated only if each and every element as set forth in the claim is found, either expressly or inherently described, in a single prior art reference.” *Verdegaal Bros., Inc. v. Union Oil Co. of Cal.*, 814 F.2d 628, 631 (Fed. Cir. 1987).

Turning first to Petitioner’s anticipation contentions, the Board is persuaded by the analysis of each of Perlman (EX1003), Yohe (EX1005), and Santos (EX1004) set forth in the Petition and supporting materials, including Appendix A, that there is a reasonable likelihood that Petitioner will prevail on those contentions as to claims 1 and 3. As to Perlman, the “digital digests” required by the claims are met by the “unique, fixed-length digest ‘signature’ whose contents are substantially less than those of the [data base].” Perlman col. 4, ll.13-20. In Yohe, this limitation is met by the “signature” generated through the MD5 or CRC protocols. Yohe col.11, ll.56-63, col.13, ll.30-39. In Santos, the compressor module calculates fixed-size “fingerprints” from packet data of arbitrary size. Santos 7-8. Similarly, Petitioner has established a reasonable likelihood that the other claim limitations are met by these references. *See* EX1001, App. A 2-11. In summary, we determine that Petitioner has met the threshold standard of demonstrating a reasonable likelihood of prevailing on the issue of whether these claims are anticipated by any one of Perlman, Yohe, or Santos.

2. *Obviousness 35 U.S.C. § 103(a)*

“Section 103 [of 35 U.S.C.] forbids issuance of a patent when ‘the differences between the subject matter sought to be patented and the prior art are such that the subject matter as a whole would have been obvious at the time the invention was made to a person having ordinary skill in the art to which said subject matter pertains.’” *KSR Int’l Co. v. Teleflex Inc.*, 550 U.S. 398, 406 (2007). To establish obviousness of a claimed invention, all the claim limitations must be taught or suggested by the prior art. *See CFMT, Inc. v. Yieldup Int’l Corp.*, 349 F.3d 1333, 1342 (Fed. Cir. 2003); *In re Royka*, 490 F.2d 981, 985 (CCPA 1974).

Petitioner has also met the threshold requirement of demonstrating a reasonable likelihood of prevailing on the issue of obviousness of claims 1 and 3 over the combination of Perlman and Yohe. Pet. 3. Our determination takes into account the detailed and credible reasons for combining the teachings of Perlman and Yohe set forth in the Declaration of Professor Darrell D. E. Long (“Long Decl.”) at 9-18, submitted by Petitioner. EX1007. Among these is the assertion that Perlman and Yohe are directed to the same problem as the ’717 patent, and propose the same solution. Long Decl. 9-10. We conclude that, taken together with the analysis of these references in the Petition including Appendix A, Petitioner has demonstrated a reasonable likelihood of prevailing on its assertion that these claims would have been obvious over Perlman and Yohe.

B. Claim 10

This independent system claim is similar to claim 1 with one significant difference: in claim 10 the receiver/computer includes means for storing the digital digest received from the network “in its permanent storage memory.” Petitioner

recognizes that Perlman uses non-permanent memory (RAM) for its cache. Pet. 9. *Also see* EX1007, Long Decl. 13. Petitioner points out that Perlman is not limited to this embodiment. Pet. 9. Nevertheless, in the absence of a specific disclosure of a permanent memory as claimed, we are not persuaded that Petitioner has sufficiently demonstrated that there is a reasonable likelihood of prevailing on the assertion that Perlman anticipates claim 10. *See infra*. However, for the reasons stated above we conclude that Petitioner has sufficiently demonstrated that there is a reasonable likelihood of prevailing on the contention that claim 10 is unpatentable over the combination of Perlman and Yohe. As there is evidence that Yohe discloses use of permanent memory (disc) for cache storage (EX1007, Long Decl. 13) and at least a rational basis for combining the references (*id.* at 11-18) there is at least a reasonable likelihood of Petitioner prevailing on the assertion that claim 10 would have been obvious over the Perlman/Yohe combination.

C. Claims 11, 12, and 14

Claim 11 is an independent method claim directed to the operation of the sender/computer. It reads as follows (with emphasis added):

11. A method performed by a sender/computer in a packet-switched network for increasing data access, said sender/computer including an operating unit, a first memory, a permanent storage memory and a processor and said sender/computer being operative to transmit data to a receiver/computer, the method comprising the steps of:

creating and transmitting a digital digest of said data from said sender/computer to said receiver/computer;

receiving a response signal from the receiver/computer at said sender/computer, *said response signal containing a positive, partial or negative indication signal for said digital digest*, and

if a negative indication signal is received, transmitting said data from said sender/computer to said receiver/computer.

Claims 12 and 14 depend directly or indirectly from claim 11. These claims are directed to the Figs. 8-10 embodiment of the '717 patent described supra, where the sender computer sends both principal and auxiliary digests to the receiver/computer. The receiver/computer in this embodiment additionally searches its network cache for the auxiliary digest if the principal digest is not found and returns a partial indication signal to the sender/computer if such a match is found. '717 patent, col. 8, ll. 28-31.

Petitioner's analysis of these claims appears at pages 13-16 of Appendix A, EX 1001. Petitioner contends that each element of claim 11 is found in Perlman, Yohe, and Santos. Petitioner proposes a broad construction of the portion of claim 11 italicized supra such that the "partial" and "positive" signals limitations are entitled to "no patentable weight" because those signals are "optional." *See* Pet. 13-14. Petitioner's proposed interpretation does not take into account the claim language in light of the specification. The '717 patent specification makes it clear that the signals are not optional; the receiver/computer described must issue a positive, negative and partial signal as required. *See, e.g.*, '717 patent Fig. 10, following:

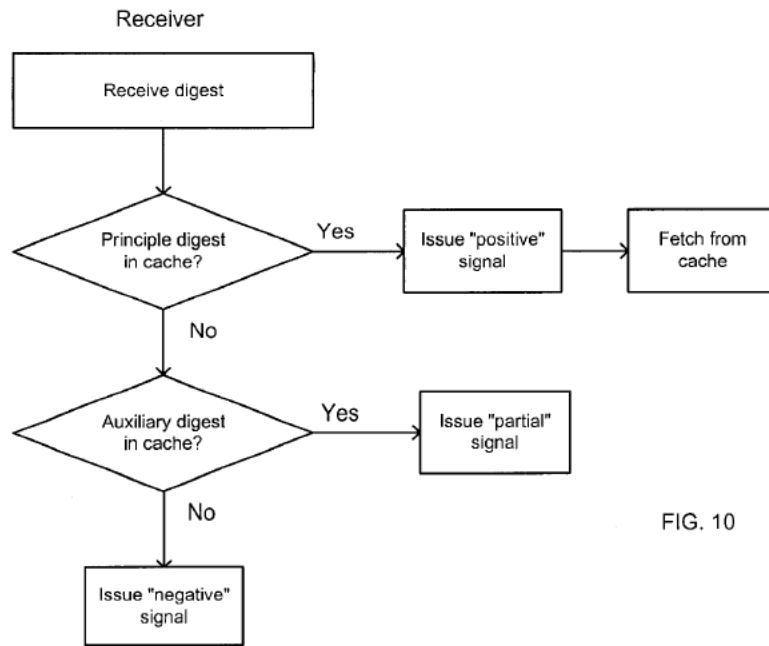

FIG. 10

Fig. 10 is a flow diagram illustrating the method of operating the receiver/computer according to the embodiment of Figs. 8 and 9. '717 patent col. 5, ll. 65-67. Accordingly, the proper interpretation of claim 11 is that the receiver/computer must issue a positive, negative, and partial signal as required.

In contrast, Petitioner argues that claim 11 only requires the receiver/computer to be capable of transmitting any one of a negative, positive or partial signal. Petitioner's argument is contrary to the specification description of Figures 8 and 9. *See supra*.

Petitioner relies (Pet. 13) on *Schumer v. Laboratory Computer Systems, Inc.*, 308 F.3d 1304 (Fed. Cir. 2002). This reliance is misplaced. The method claim in *Schumer* was directed to a digitizing tablet or digitizer "receiving a definition of a second coordinate system for the digitizer, which ... is not congruent with the digitizer's coordinate system because one of the following [three] elements is different ..." *Schumer*, supra at 1312 (internal quotes omitted). The three elements represented three separate attributes of a digitizer coordinate system: point of

origin, angle of rotation, and scale. *Id.* at 1311. The method in *Schumer* did not depend on the capability of translating all three recited elements, for the accused infringers omitted one. *Id.* at 1308-09. The Court thus construed this language as encompassing a method where any one element (e.g., scale) of the three recited in the claim is translated. *Id.* at 1312. *Schumer* is therefore distinguishable from '717 patent claim 11 where producing all three signals is required in light of the specification and is not optional.

Petitioner also cites *Brown v. 3M*, 265 F.3d 1349 (Fed. Cir. 2001). Pet. 13. In *Brown* the claim, directed to solving the Y2K problem, recited three alternative year-date representations (i.e., two-digit, three-digit, and four-digit). The invention was capable of adjusting computer programs containing any one of such date systems. *Id.* at 1352 (“The *Brown* invention includes adjustment of programs containing any such date systems.”). Thus, the Court held that the apparatus claim covered two-digit, three-digit, and four-digit implementations, as well as any combination. *Id.* As in *Schumer*, the ability to act on all three alternatives was not necessary to the claimed invention in *Brown*. Finally, Petitioner suggests that Patent Owner’s own litigation infringement contentions support Petitioner’s position that each type of signal is not required. Pet. 14. The Board is not persuaded by this argument as Petitioner provides no further explanation of the cited exhibit, EX1012.

Petitioner advances a similar contention that the final element in this claim (“if a negative indication signal is received...”) is entitled to no patentable weight because it is “conditional.” Pet. 24; App. A at 15. In support, Petitioner cites a non-precedential decision of this Board in *Ex Parte De Gaulle*, Appeal No. 2008-6183 (BPAI February 10, 2009). This case does not support Petitioner’s position. As Petitioner acknowledges, the method steps under review in *Ex Parte De Gaulle*

were contingent on conditions that the claims did not require to occur. Pet. 24; *De Gaulle* slip op. at 9. We are not persuaded by Petitioner's argument because in claim 11, the recitation of the negative indication signal in the preceding step distinguishes the claim from *De Gaulle*.

Alternatively, Petitioner contends that Perlman, Yohe, and Santos disclose this final step of claim 11. Pet. 24; App. A at 15. As this argument is premised on Petitioner's erroneous claim construction we are not persuaded of a reasonable likelihood of prevailing.

We conclude that Petitioner has failed to demonstrate that Perlman, Yohe, or Santos teach or suggest "said response signal containing a positive, partial or negative indication signal for said digital digest" as required by claim 11.

Claims 12 and 14 depend from claim 11 and thus include the elements not taught or suggested by the references discussed supra. Claim 14 additionally requires sending "a plurality of data items." Petitioner contends this recitation is not entitled to patentable weight because it is conditional. Pet. 25; App. A at 16. We disagree for the same reasons expressed above with respect to claim 11.

D. Claims 22-24

Claim 22 is an independent method claim directed to the operation of the receiver/computer. It reads as follows:

22. A method for increased data access performed by a receiver/computer in a packet-switched network, said receiver/computer including an operating unit, a first memory, a permanent storage memory, a processor and a network cache memory, said method comprising the steps of:

receiving a message containing a digital digest from said network;
searching for data with the same digital digest in said network cache memory,

if data having the same digital digest as the digital digest received is not uncovered, forming a negative indication signal and transmitting it back through said network; and
creating a digital digest for data received from said network cache memory.

Petitioner's analysis of claim 22 and its dependent claim 23 appears at pages 16-19 of Appendix A. EX1001. The analysis is similar to that of claims 1 and 10 supra. We therefore conclude that for reasons previously stated Petitioner has demonstrated a reasonable likelihood of prevailing on its contention of anticipation of those claims by Perlman, Yohe, or Santos, and on obviousness over the Perlman/Yohe combination. Claim 24 additionally recites "a plurality of digital digests" received in the same message, and an "indication signal" that is "generated separately for each of said data objects." We agree with Petitioner that Perlman's bundling of high-level identifiers and separate low-level database identifiers for separate fragments discussed supra is reasonably likely to meet this limitation. *See* Pet. 29; App. A 19.

V. SUMMARY

Petitioner has demonstrated that there is a reasonable likelihood of prevailing on its challenge to the patentability of the following claims of the '717 patent: claims 1, 3, 10, and 22-24. Petitioner has not demonstrated a reasonable likelihood of prevailing on its challenge to the patentability of the following claims of the '717 patent: claims 11, 12, and 14.

The Petition is granted as to the following grounds:

- I. Anticipation by Perlman: claims 1, 3, and 22-24.
- II. Anticipation by Yohe: claims 1, 3, 10, 22, and 23.

III. Anticipation by Santos: claims 1, 3, 10, 22, and 23.

IV. Obviousness over the combination of Perlman and Yohe: claims 1, 3, 10, and 22-24.

VI. ORDER

In consideration of the foregoing, it is hereby:

ORDERED that the Petition is granted as to claims 1, 3, 10, and 22-24 of the '717 patent.

FURTHER ORDERED that the Petition is denied as to claims 11, 12, and 14 of the '717 patent.

FURTHER ORDERED that pursuant to 35 U.S.C. § 314(a), inter partes review of the '717 patent is hereby instituted commencing on the entry date of this Order, and pursuant to 35 U.S.C. § 314(c) and 37 C.F.R. § 42.4, notice is hereby given of the institution of a trial.

FURTHER ORDERED that the trial is limited to the grounds identified as I – IV above and no other grounds are authorized.

FURTHER ORDERED that an initial conference call with the Board is scheduled for 2 PM EST on January 22, 2013. The parties are directed to the Office Trial Practice Guide, 77 Fed. Reg. 48756, 48765-66 (Aug. 14, 2012) for guidance in preparing for the initial conference call, and should come prepared to discuss any proposed changes to the Scheduling Order entered herewith and any motions the parties anticipate filing during the trial.

For Patent Owner

Matthew L. Cutler
Harness, Dickey & Pierce, PLC
mcutler@hdp.com

IPR2012-00026
Patent 6,757,717

Bryan K. Wheelock
Harness, Dickey & Pierce, PLC
bwheelock@hdp.com

For Petitioner

John D. Vandenberg
Klarquist Sparkman LLP
john.vandenberg@klarquist.com

Stephen J. Joncus
Klarquist Sparkman LLP
stephen.joncus@klarquist.com