

PRECEDENTIAL OPINION

Pursuant to the Board of Patent Appeals and Interference's Standard Operating Procedure 2, the opinion below has been designated a precedential opinion.

Paper No. 22

UNITED STATES PATENT AND TRADEMARK OFFICE

**BEFORE THE BOARD OF PATENT APPEALS
AND INTERFERENCES**

Ex parte DANIEL M. EGGERT and FRANK MIKIC (deceased)

Appeal No. 2001-0790
Application No. 09/110,145¹

DECIDED: May 29, 2003

Before STONER, Chief Administrative Patent Judge, HARKCOM, Vice Chief Administrative Patent Judge, WILLIAM F. SMITH, ABRAMS, FRANKFORT, BARRETT, FLEMING, NASE, BAHR, PAWLIKOWSKI and NAGUMO, Administrative Patent Judges.
Per curiam.

ON REQUEST FOR REHEARING

This is a decision in response to the examiner's request for rehearing (Paper No. 20, mailed January 18, 2002) of the decision of a three-member panel of this Board mailed August 3, 2001 (Paper No. 17) reversing the examiner's rejection of reissue

¹ Application for reissue of U.S. Pat. No. 5,577,426, issued November 26, 1996, on Application No. 08/335,992 (hereinafter "the '992 application"), filed November 8, 1994.

claims 15-22 under 35 U.S.C. § 251 as being an improper recapture of broadened subject matter surrendered in the application for the original patent. Appellants filed a response to this request on March 28, 2002 (Paper No. 21). The panel has subsequently been expanded by the Chief Judge to eleven members to decide the examiner's request.

For the following reasons, we conclude that the original panel did not err in its earlier decision in concluding that reissue claims 15-22 are not precluded by the recapture rule.

PREFACE

Prior to discussing the complex legal and technical issues involved in this appeal we believe it would be helpful to provide a summary of our decision and reasons in support. We shall make reference to Drawing 1 in doing so.



Drawing 1

There came a time in the prosecution of the '992 application that claim 1 (once amended) was presented for examination and was met by a final rejection from the examiner under 35 U.S.C. § 103. At that time, appellants were presented with a number of options for proceeding with the quest for patent protection. One was to appeal the examiner's final rejection of claim 1 (once amended) to this Board. Another was to concede that rejected claim 1 (once amended) was unpatentable and to amend that claim in an attempt to define narrower, patentable subject matter. Appellants chose the latter option and amended claim 1 a second time. Upon consideration of claim 1 (twice amended), the examiner determined that it was patentable. Thus, claim 1 (twice amended) became issued claim 1.

The changing scope of a claim during the administrative examination process as it is amended to overcome prior art rejections can be viewed as a series of concentric circles. As illustrated in Drawing 1, the scope of rejected claim 1 (once amended) is the outer circle and the scope of amended issued claim 1 (twice amended) is the inner circle. The shaded area between the circles represents subject matter which is only narrower than the scope of the rejected claim but only broader than the scope of the issued claim. In our view, the surrendered subject matter is the outer circle of Drawing 1 because it is the subject matter appellants conceded was unpatentable. The subject matter of the shaded area was not subject to the administrative examination process as the examiner was never directly presented with a claim which fell within the scope of the shaded area. Thus, appellants have never conceded that a claim falling within the

scope of the shaded area of Drawing 1 is unpatentable and therefore, in our view, such subject matter is not barred by the recapture rule.

Due to the vagaries of using words to describe a mechanical object such as the bit holder of the present invention, it is not unreasonable to conclude that errors can be made in choosing the most correct language to define a mechanical object in a way which is consistent with the invention described in a patent application and is patentable over the prior art. This is recognized in the patent statutes in a number of ways, e.g., the ability of applicant to amend claims pending in an application. The patent statute also envisions that errors made without deceptive intent can be corrected after a patent has issued under defined circumstances. 35 U.S.C. § 251. Thus, a patentee who believes he has claimed less than he had a right to claim in the patent through error without any deceptive intent may file an application for a reissue patent. However, a reissue application seeking to enlarge the scope of the claims must be filed within two years of the grant of the original patent.

In the present case appellants believe that in further amending claim 1 (once amended) in an attempt to define patentable subject matter, they, in essence, overshoot the mark in narrowing the claim by using the language added to claim 1 (twice amended), i.e., that they claimed less than they had a right to claim, and they now wish to “retreat” back from the inner circle shown in Drawing 1 into the shaded area between the circles in a further attempt to define alternative patentable subject matter. The present reissue application was filed within two years of the grant of the original patent

and no issue of deceptive intent has been raised on this record. Importantly, the examiner has not rejected the claim under 35 U.S.C. §§ 101, 102, 103, or 112.

However, in this case, appellants have run into a rejection based on a doctrine known as the “reissue recapture rule.” The judicial development of this doctrine is complex and is recounted and discussed in the briefing of this appeal, the original opinion of this Board and below. In the request for rehearing, it appears that the examiner has asked this Board to impose a per se rule of reissue recapture to prevent appellants from retreating from any claim limitation determined to have secured allowance of the original patent. For the reasons set forth below, we decline to do so.

In our opinion, to adopt such a per se rule would be contrary to the language of 35 U.S.C. § 251 which permits broadened claims in a reissue patent. That is not to say that appellants are unfettered in amending their issued claims in their reissue application. Appellants’ decision not to appeal the examiner’s rejection of claim 1 (once amended) but to amend the claim and attempt to define narrower, patentable subject matter constitutes an irrevocable admission that a claim of that scope, the outer circle in Drawing 1 and broader, is unpatentable. Appellants had their chance to test the correctness of the examiner’s rejection by way of appeal to this Board and chose not to do so. Appellants therefore cannot retreat all the way through the shaded area of Drawing 1 in this reissue and revisit that issue. Thus, claim 1 (once amended) constitutes surrendered subject matter under the “reissue recapture rule,” but the issued claim does not.

For example, if an outer circle claim contains elements ABC and the inner circle claim contains elements ABCDEF, a reissue applicant cannot recapture a claim directed to elements ABC (outer circle) or a claim entirely outside the outer circle (e.g., AB, BC, ABC_{BR}², etc.). However, it is our view that the reissue recapture rule is not invoked for claims directed to elements ABCX, ABCD_{BR}, ABCEF, A_{BR}BCDEF. In other words, the focus for determining the reach of the reissue recapture rule should be the claim from which the issued claim directly evolved, not the issued claim itself. We believe that this is where we and the members of the dissent disagree.

Another way of viewing the present circumstances is to understand that a claim such as claim 1 (once amended) represents or includes a number of discrete embodiments. It cannot be assumed that an examiner's rejection of a claim such as claim 1 (once amended) is a finding that all embodiments within the claim are unpatentable. Rather, an examiner's prior art may only reach or make obvious a limited number of embodiments within the scope of a claim. However, it has long been held that claims which encompass arguably non-obvious subject matter as well as obvious subject matter are unpatentable.³ Thus, such a claim is unpatentable and must be further amended. Given the difficulties in defining mechanical objects using the English

² The subscript BR designates a broader element, thus element C_{BR} is broader than element C.

³ See, e.g., *In re Mraz*, 455 F.2d 1069, 1072-73, 173 USPQ 25, 28 (CCPA 1972 ("[C]laims are unpatentable when they are so broad as to read on obvious subject matter even though they likewise read on non-obvious subject matter."); *In re Muchmore*, 433 F.2d 824, 826, 167 USPQ 681, 683 (CCPA 1970) ("[C]laim 14 is too broad in the sense of section 103, since it reads on both obvious and unobvious subject matter.").

language, it is not unexpected that in choosing language to exclude “obvious” embodiments from claim 1 (once amended), yet retain all “non-obvious” embodiments, the claim drafter may have erred in choosing the amendatory language, including the language used in the limitations which the record would indicate secured allowance of the patented claims. On this record, this is what has happened here. In our view, such errors are correctable under the terms of 35 U.S.C. § 251 if the claim otherwise meets the statutory requirements.

Appellants’ specification discloses two embodiments at issue in this appeal. The first embodiment is shown in Figures 2 and 3.

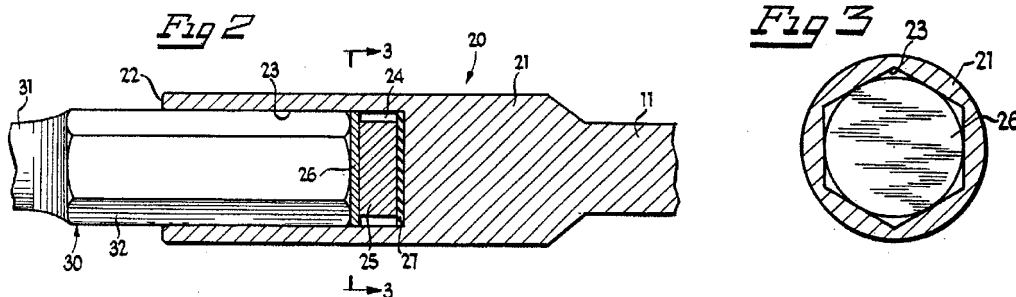

First Embodiment of Eggert

Figure 2 shows a bit holder 20 having a magnet 25 held in place by a retainer 26 which is made of suitable metal and is shaped as a flat circular disk. See column 2, line 53 - column 3, line 5 of the Eggert patent. Figure 3 is a view of a vertical section taken along the line 3-3 in Figure 2. Figure 3 shows the circular retainer 26 friction fitted in an axial hexagonal bore 23.

The second embodiment is shown in Figures 4, 5 and 6.

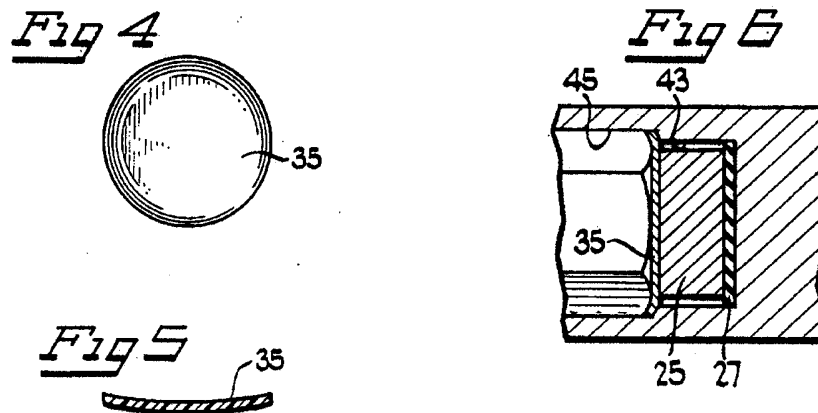

Second Embodiment of Eggert

In the second embodiment, an alternative bit holder is shown which is similar to bit holder 20 in the first embodiment except for the nature of the bore and the retainer. More specifically, the bit holder of Figure 6 has a cylindrical body which has a circularly cylindrical axial bore 43 in addition to an hexagonal bore 45. See column 3, lines 48-55. Figure 6 shows that magnet 25 is dimensioned to fit freely in the cylindrical bore 43 and is held in place by a retainer 35 friction fitted in the hexagonal bore 45. See column 3, lines 59-64. Figures 4-6 show that the retainer 35 is formed of suitable plastic material and generally bowl-shaped and convex toward the magnet. See column 3, lines 35-47.

Appellants' original independent claim 1 recited the language "retaining structure in contact with the outer surface of said magnet and interference fitted in said bore to

retain said magnet in said bore.” Original claim 1, thus, encompassed both the first and second embodiments of Eggert.⁴ The examiner applied U.S. Patent No. 4,663,998 to Parsons for a teaching of the broadly claimed retaining structure.

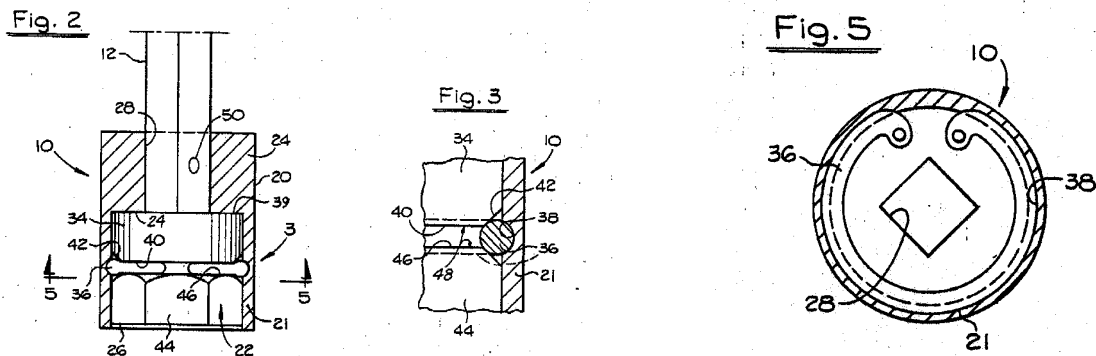

Parsons Embodiment

Parsons shows in Figure 2 an axial sectional view of a magnetic wrench socket 10. Figure 2 shows magnet 34 held in a cylindrical bore by means of a C ring 36. See column 1, lines 35-65, of Parsons. Figure 3 of Parsons is a large scale sectional view of a portion of Figure 2 indicated by arrow 3. Figure 3 shows the C ring 36 releasably held in a peripheral groove 38 formed in the wall 21. See column 1, lines 29 and 30, and lines 60-65. Figure 5 of Parsons shows a sectional view taken at line 5-5 of Figure 2 and shows C ring 36 releasably held in peripheral groove 38 formed in the wall 21. See column 1, lines 34 and 35, and lines 60-65. Thus, Parsons describes what in essence is a third embodiment covered by the language of appellants' original claim 1.

⁴ Original claim 1 also encompassed the encapsulated magnet embodiments shown in Figures 7-9 of Eggert.

In response to the examiner's rejection applying Parsons to the claimed retaining structure, appellants filed an amendment adding the language "said retaining structure including a discrete retaining member friction fitted in said bore outboard of said magnet, said retaining member and said inner end surface cooperating to retain said magnet therebetween" (claim 1 (once amended)).

We note that this language presented in once amended independent claim 1 continued to encompass both the first and second embodiments of Eggert.⁵ In other words, the language is of such scope that it would include both a solid flat metal disk 26 as shown in Figures 2 and 3 (the first embodiment) and the plastic disk which is concave away from the magnet as shown in Figures 4, 5 and 6 (the second embodiment).

Also at that time in the prosecution, the application contained claim 6 which was dependent upon claim 1; claim 6 was solely directed to the second embodiment. Claim 6 added to claim 1 the limitation of "said retaining member being generally bowl-shaped and convex toward said magnet." This claim language corresponds only to the second embodiment disclosed in Figures 4, 5 and 6.

In response to the above-noted amendment to claim 1, the examiner disagreed with the appellants' assertions of patentability of claim 1 (once amended) and maintained that the claimed retaining structure including a discrete retaining member

⁵ Once amended claim 1 no longer encompassed the encapsulated magnet embodiments shown in Figures 7-9 of Eggert since the encapsulated magnet embodiments do not have a discrete (i.e., constituting a separate thing; distinct; consisting of unconnected distinct parts) retaining member friction fitted in the bore outboard of the magnet.

friction fitted in the bore was readable on the C ring of Parsons. The examiner then made the ensuing rejection final. In response, appellants filed an after final amendment which simply rewrote dependent claim 6 into independent form thereby having claim 1 (twice amended) include the limitation of the retaining member being generally bowl-shaped and convex toward the magnet. The examiner entered the after final amendment and allowed the claim. However, in their after final amendment of claim 1 the appellants chose non-generic language which excluded their disclosed first embodiment which is a flat, circular metal disk.⁶ This is the error which appellants now wish to correct by reissue.

To this end, appellants present in this reissue application new independent claims 15 and 22 which are sufficient in scope to not only cover both of their disclosed embodiments, but also distinguish over the C ring of Parsons. For example, the new language of claim 15 reads “a discrete retaining member friction fitted in said bore outboard of said magnet and substantially covering said outer surface of said magnet to retain said magnet in the bore.” The scope of this language includes both the first and second embodiments of appellants’ invention, and as recognized by the examiner, is free of the prior art on this record.

⁶ Appellants filed a “divisional” Application No. 08/593,396 of the ‘992 application on January 29, 1996. A preliminary amendment filed concurrently with the filing of this application included an amendment reciting “said retaining structure including a discrete, flat, imperforate retaining member.” This is evidence that appellants did not surrender to the public the first embodiment of Eggert which is a flat, circular metal disk. This “divisional” application issued as U.S. Patent No. 5,603,248 on February 18, 1997. A reissue application of U.S. Patent No. 5,603,248 was filed on July 2, 1998. A reissue patent was granted on August 1, 2000 (RE 36,797).

Appellants' after final amendment of claim 1 establishes the subject matter of finally rejected claim 1 as surrendered subject matter (the outer circle of Drawing 1) since the after final amendment (the inner circle of Drawing 1) was a concession on appellants' part that finally rejected claim 1 was unpatentable. The limitation of newly added reissue claim 15 of "a discrete retaining member friction fitted in said bore outboard of said magnet and substantially covering said outer surface of said magnet to retain said magnet in the bore" represents subject matter within the shaded area of Drawing 1.

No doubt, all concerned wish that appellants would have arrived at the language now presented in reissue claims 15 and 22 during prosecution of the '992 application. However, errors in choosing the most appropriate claim language during prosecution do occur. The reissue statutes provide a means and process for correcting such errors in a manner consistent with the notice function of patent claims.

We point out that the patent statutes relating to reissue provide for both (1) public notice that patent claims can be broadened in a reissue application filed within a two-year period after issuance of the patent and (2) intervening rights. 35 U.S.C. §§ 251 and 252. In addition, the public is notified by the USPTO when a reissue application is filed and has access to that application during its pendency. 37 CFR § 1.11(b); Manual of Patent Examining Procedure (MPEP) § 1430. This in contrast to the situation involving an applicant who may file a continuing application to

pursue broader claims in relative secrecy⁷ without the two-year constraint and intervening rights provisions provided for by the reissue statutes. The applicant who uses the continuing application route to pursue broader claims also would not be constrained in any sense by the reissue recapture rule or be barred by prosecution history estoppel from obtaining claims of the same scope as or broader than the claims canceled in the parent application. Given the alternatives discussed above, we do not see the wisdom of imposing a per se rule like that requested by the examiner which would motivate applicants to file otherwise unnecessary continuing applications to pursue broader claims and thereby avoid intervening rights. In our view, focusing the starting point of a reissue recapture rule analysis on the claim that was amended to become the issued claim, i.e., the canceled, outer circle claim of Drawing 1, instead of the issued, inner circle claim of Drawing 1, itself will result in the corrected patent rights of a patentee being resolved more quickly and in a more public manner.

DECISION

The examiner's request (page 2) asserts that "the Board erred as a matter of law in holding that the 'surrendered subject matter' that cannot be recaptured in a reissue is limited to the claims canceled or amended during prosecution of the application that matured into the '426 patent after a rejection of those claims based on prior art." Further, the request urges this Board to apply a per se rule that "[a]fter the addition of a

⁷ The subject matter of the continuing application would usually be published as provided by 35 U.S.C. § 122(b).

claim limitation to secure allowance of a patent, an attempt to subsequently obtain patent protection by reissuing the patent with one or more claims that do not contain that limitation is impermissible because this is not a [correctable] error” (request, page 3). According to the examiner (request, page 4), the Board committed error when it held, in the earlier decision, “that the substitution in the reissue application of the limitation ‘and substantially covering said outer surface of said magnet’ for the limitation ‘generally bowl-shaped, being convex toward said magnet’ of the original patent was [correctable] error under 35 U.S.C. § 251.”

For the reasons which follow, we conclude that the original merits panel did not err in refusing to apply a per se rule that, after a limitation is added to a claim or argued to be significant in distinguishing a claim over prior art applied in a rejection, any reissue claim which does not contain that limitation is per se impermissible. The rigid approach urged by the examiner, in our opinion, is neither consistent with the remedial nature of the reissue statutes nor supported by the legal precedent of our reviewing courts.

The reissue statutes

35 U.S.C. § 251, ¶ 1, provides in pertinent part:

Whenever any patent is, through error without any deceptive intention, deemed wholly or partly inoperative or invalid, by reason of a defective specification or drawing, or by reason of the patentee claiming more or less than he had a right to claim in the patent, the Director shall . . . reissue the patent for the invention disclosed in the original patent, and in accordance with a new and amended application, for the unexpired part of the term of the original patent.

35 U.S.C. § 251, ¶ 4, provides:

No reissued patent shall be granted enlarging the scope of the claims of the original patent unless applied for within two years from the grant of the original patent.

35 U.S.C. § 252, ¶ 2, provides:

A reissued patent shall not abridge or affect the right of any person or that person's successors in business who, prior to the grant of a reissue, made, purchased, offered to sell, or used within the United States, or imported into the United States, anything patented by the reissued patent, to continue the use of, to offer to sell, or to sell to others to be used, offered for sale, or sold, the specific thing so made, purchased, offered for sale, used, or imported unless the making, using, offering for sale, or selling of such thing infringes a valid claim of the reissued patent which was in the original patent. The court before which such matter is in question may provide for the continued manufacture, use, offer for sale, or sale of the thing made, purchased, offered for sale, used, or imported as specified, or for the manufacture, use, offer for sale, or sale in the United States of which substantial preparation was made before the grant of the reissue, and the court may also provide for the continued practice of any process patented by the reissue that is practiced, or for the practice of which substantial preparation was made, before the grant of the reissue, to the extent and under such terms as the court deems equitable for the protection of investments made or business commenced before the grant of the reissue.

While we appreciate the dissent's concern for the rights of the public in relying on prosecution history to determine the scope of activities that constitute infringement of the patent claims, we also recognize that (1) the fourth paragraph of 35 U.S.C. § 251 clearly places the public on notice that the scope of claims of a patent may be

broadened in a reissued patent applied for within two years from the grant of a patent and (2) the second paragraph of 35 U.S.C. § 252 provides safeguards which protect the rights and investments of persons who, prior to the grant of a reissued patent, made, purchased, offered to sell, used in the United States, imported into the United States or made substantial preparation for such activities anything patented by the reissued patent and not patented by the original patent. In other words, Congress, while permitting broadening of patent claims by reissue within two years from the grant of a patent to correct errors made by a patentee without deceptive intent, has provided for intervening rights to protect investments made by persons in reliance on the prosecution history of a patent in furtherance of activities which were not covered by the original patent claims but are covered by broadened reissue claims. In this regard, the reissue process stands apart from and in contrast to the application of the doctrine of equivalents, wherein intervening rights are not provided to protect the public from reliance on prosecution history estoppel in interpreting the scope of a patent claim. This is also in contrast to the filing of a continuing application by an applicant to pursue broader claims in relative secrecy, as compared with the more public proceedings in reissue applications⁸, without the two-year constraint and intervening rights provided by the reissue statutes. The applicant who uses the continuing application route would also not be constrained in any sense by the reissue recapture rule. Given these

⁸ The public is notified by the USPTO when a reissue application is filed and has access to the application during its pendency. 37 CFR § 1.11(b); MPEP 1430.

alternatives, imposing the per se rule urged by the examiner would appear only to push applicants to file continuing applications to pursue broader claims in a manner which does not ensure the safeguards afforded by the reissue statutes.

The precedent

With respect to a different but related issue, namely, prosecution history estoppel, the United States Supreme Court recently recognized that:

[u]nfortunately, the nature of language makes it impossible to capture the essence of a thing in a patent application. The inventor who chooses to patent an invention and disclose it to the public, rather than exploit it in secret, bears the risk that others will devote their efforts toward exploiting the limits of the patent's language:

“An invention exists most importantly as a tangible structure or a series of drawings. A verbal portrayal is usually an afterthought written to satisfy the requirements of patent law. This conversion of machine to words allows for unintended idea gaps which cannot be satisfactorily filled. Often the invention is novel and words do not exist to describe it. The dictionary does not always keep abreast of the inventor. It cannot. Things are not made for the sake of words, but words for things.” Autogiro Co. of America v. United States, 384 F.2d 391, 397 [155 USPQ2d 697] (Ct. Cl. 1967).

The language in the patent claims may not capture every nuance of the invention or describe with complete precision the range of its novelty. If patents were always interpreted by their literal terms, their value would be greatly diminished. Unimportant and insubstantial substitutes for certain elements could defeat the patent, and its value to inventors could be destroyed by simple acts of copying. For this reason, the clearest rule of patent interpretation, literalism, may conserve judicial resources but is not necessarily the most efficient rule. The scope of a patent is not limited to its literal terms but instead embraces all equivalents to the claims described. See Winans v. Denmead, 15 How. 330, 347 (1854).

Festo Corp. v. Shoketsu Kinzoku Kogyo Kabushiki Co., 122 S.Ct. 1831, 1837, 62 USPQ2d 1705, 1709-10 (2002). The United States Supreme Court also acknowledged that patent applicants should not be presumed to have had more foresight in making such amendments than an applicant whose application was granted without amendments having been submitted. Id. at 1841, 62 USPQ2d at 1712.

Moreover, with respect to the reissue statute, as recently explained by our reviewing court in In re Doyle, 293 F.3d 1355, 1358, 63 USPQ2d 1161, 1164 (Fed. Cir. 2002):

[b]y its terms section 251 restricts reissue to situations in which an error occurred – situations that include the patentee having “claim[ed] more or less than he had a right to claim in the patent.” “The statute is remedial in nature, based on fundamental principles of equity and fairness, and should be construed liberally.” In re Weiler, 790 F.2d 1576, 1579, 229 USPQ 673, 675 (Fed. Cir. 1986).

We are also mindful, however, of the admonition that:

[e]rror under the reissue statute does not include a deliberate decision to surrender specific subject matter in order to overcome prior art, a decision which in light of subsequent developments in the marketplace might be regretted. It is precisely because the patentee amended his claims to overcome prior art that a member of the public is entitled to occupy the space abandoned by the patent applicant. Thus, the reissue statute cannot be construed in such a way that competitors, properly relying on prosecution history, become infringers when they do so.

Mentor Corp. v. Coloplast Inc., 998 F.2d 992, 996, 27 USPQ2d 1521, 1525 (Fed. Cir. 1993). This is the underlying policy behind what has come to be known as the “reissue

recapture rule.” In its simplest terms, this rule may be summarized as follows: A patentee is precluded from recapturing in reissue that which he earlier conceded was unpatentable and abandoned or surrendered, whether by cancellation, amendment or argument of claims, for the purpose of obtaining the original patent.

Accordingly, it seems clear to us that the reissue recapture rule focuses on that which the prosecution history indicates was given up or conceded to be unpatentable by an applicant, i.e., the “surrendered subject matter,” in order to obtain a patent, for this is the subject matter which cannot be recaptured in reissue. Indeed, the examiner, appellants and the original panel all appear to be in agreement on this broad principle. The nature of the dispute appears to reside in the manner in which the surrendered subject matter is to be determined.

The examiner contends that the recapture rule prohibits a patentee from obtaining in reissue any claim which does not include each and every limitation added to a claim or argued by an applicant during the prosecution of the original patent application in order to overcome a rejection and obtain a patent, citing Shepard v. Carrigan, 116 U.S. 593 (1886); In re Byers, 230 F.2d 451, 456-57, 109 USPQ 53, 57 (CCPA 1956)⁹ and Riley v. Broadway-Hale Stores, Inc., 217 F.2d 530, 532, 103 USPQ

⁹ The examiner’s characterization of Byers as addressing the issue of patentability of reissue claims of intermediate scope, that is, broader than the patent claim yet narrower than certain canceled claims in the application, is misguided, in that the basis of the holding that reissue claims 2 and 3 were impermissible was the fact that the reissue claims were broader in some respects and not narrower in any respect than original claim 20 prior to its amendment. The court emphasized that the rejection was not

(continued...)

414, 416 (9th Cir. 1954) as support for this proposition (request, page 10). This approach, while certainly relatively simple in its application, has been expressly rejected by the Court of Customs and Patent Appeals (CCPA) and the Court of Appeals for the Federal Circuit (Federal Circuit).

With respect to Shepard, the CCPA, in In re Richman, 409 F.2d 269, 274-75, 161 USPQ 359, 363 (CCPA 1969), noted that:

Referring back to Shepard, however, it is apparent that the situation there was one in which the omission of the added limitation would have resulted in the claim being drawn to the same subject matter as the original rejected claim, to which the limitation was added, thus making it unpatentable over the prior art for the same reason as the original claim. We therefore [do not] find [the Shepard decision] to be authority for the proposition that a limitation added to a claim in obtaining allowance cannot be broadened, under present statutory law, by reissue if the limitation turns out to be more restrictive than the prior art required. Certainly one might err without deceptive intention in adding a particular limitation where a less specific limitation regarding the same feature, or an added limitation relative to another element, would have been sufficient to render the claims patentable over the prior art.

In Ball Corp. v. United States, 729 F.2d 1429, 1435, 221 USPQ 289, 294 (Fed. Cir. 1984), the Federal Circuit pointed out that the CCPA had repeatedly held that the deliberate cancellation of claims may constitute error, within the context of § 251 if it

⁹ (...continued)
based on the cancellation of the other broader claims but on the limiting amendment of original claim 20; “[t]he fact that there were other claims whose cancelation did not constitute such a bar is immaterial.” Byers, 230 F.2d at 456-57, 109 USPQ at 57.

occurs without deceptive intent and emphasized that “the CCPA went so far as to state that error is sufficient where the deliberate cancellation of claims does not amount to an admission that the reissue claims were not patentable at the time the original claims were canceled.” The Federal Circuit then expressly declined to adopt “the rigid standard” applied in Riley, namely, “when the chief element added by reissue has been abandoned while seeking the original patent, the reissue is void,” in favor of the more liberal approach taken by the CCPA. Ball at 1436, 221 USPQ at 294. According to Ball,

[t]he recapture rule bars the patentee from acquiring, through reissue, claims that are of the same or of broader scope than those claims that were canceled from the original application. On the other hand, the patentee is free to acquire, through reissue, claims that are narrower in scope than the canceled claims.

Id. at 1436, 221 USPQ at 295. Ball also establishes that “[t]he proper focus is on the scope of the claims, not on the individual feature or element purportedly given up during prosecution of the original application.” Id. at 1437, 221 USPQ at 295. This approach is consistent with the CCPA’s determination in Byers¹⁰ that the applicant’s “action in limiting the scope of original claim 20 by amendment constituted a deliberate withdrawal of that claim as originally presented, in order to obtain a patent, and that such withdrawal is a bar to the obtaining by reissue of claim 20 as it originally stood, or of any

¹⁰ 230 F.2d at 456, 109 USPQ at 56

claim differing therefrom only by being broader.”¹¹ The importance of focusing on the scope of the claims in determining whether a reissue claim is impermissible under the recapture rule is also emphasized in In re Willingham, 282 F.2d 353, 356, 127 USPQ 211, 215 (CCPA 1960), wherein it was pointed out that “the issue before us is not the issue presented in many reissue cases in which an applicant cancels a claim to secure the issuance of the patent and then seeks to recapture it by a claim of the same scope in a reissue application.” The CCPA further stated therein that:

[t]he deliberate cancellation of a claim of an original application in order to secure a patent cannot ordinarily be said to be an “error” and will in most cases prevent the applicant from obtaining the cancelled claim by reissue. The extent to which it may also prevent him from obtaining other claims differing in form or substance from that cancelled necessarily depends upon the facts in each case and particularly on the reasons for the cancellation.

Id. at 357, 127 USPQ at 215.

In Mentor, 998 F.2d at 995, 27 USPQ2d at 1524, the Federal Circuit reiterated its statement from Ball that “[t]he recapture rule bars the patentee from acquiring, through reissue, claims that are of the same or of broader scope than those claims that were cancelled from the original application” and went on to add that

[r]eissue claims that are broader in certain respects and narrower in others may avoid the effect of the recapture rule. If a reissue claim is broader in a way that does not attempt to reclaim what was surrendered earlier, the recapture rule may not apply. However, in this case, the reissue claims are

¹¹ It is noteworthy that the CCPA identified the surrendered subject matter which cannot be recaptured in reissue as the claim “as originally presented” prior to the amendment, as distinguished from any claim not containing the limitation added to obtain allowance.

broader than the original patent claims in a manner directly pertinent to the subject matter surrendered during prosecution. Mentor thus attempted to reclaim what it earlier gave up. Moreover, the added limitations do not narrow the claims in any material respect compared with their broadening.

Id. at 996, 27 USPQ2d at 1525. The language of Mentor refers both to a comparison of the scope of the reissue claim relative to the cancelled claim and to a comparison of the scope of the reissue claim relative to the original patent claims. To the extent one may perceive an inconsistency, it is resolved by In re Clement, 131 F.3d 1464, 1468-72, 45 USPQ2d 1161, 1163-67 (Fed. Cir. 1997), which we think provides more explicit guidance as to what is meant by “broader in a manner directly pertinent to the subject matter surrendered during prosecution,” as will be made more clear in our discussion infra. In any event, the holding in Mentor was that a reissue claim does not avoid the recapture rule when the reissue claim has been (1) broadened relative to the original patent claims by omitting a limitation expressly added and relied upon by the patentee in order to obtain the patent in favor of language which the patentee had conceded during prosecution of the patent application was met by the prior art; and (2) not narrowed in any material respect compared with the broadening.

In Clement, 131 F.3d at 1468, 45 USPQ2d at 1163-64, the Federal Circuit stated that, while an attorney’s failure to appreciate the full scope of the invention qualifies as error under § 251 and is correctable by reissue, the recapture rule “prevents a patentee from regaining through reissue the subject matter that he surrendered in an effort to obtain allowance of the original claims.” Reiterating the language used in Mentor, the

Federal Circuit confirmed that, “[u]nder this rule, claims that are ‘broader than the original patent claims in a manner directly pertinent to the subject matter surrendered during prosecution’ are impermissible.” Id. at 1468, 45 USPQ2d at 1164. The Clement decision then explains how this rule is applied, i.e., how it is determined whether claims are “broader than the original patent claims in a manner directly pertinent to the subject matter surrendered during prosecution.”

Under the test set forth in Clement, “[t]he first step in applying the recapture rule is to determine whether and in what ‘aspect’ the reissue claims are broader than the patent claims. For example, a reissue claim that deletes a limitation or element from the patent claims is broader in that limitation’s aspect.” Id. “The second step is to determine whether the broader aspects of the reissue claims relate to surrendered subject matter.” Id. at 1468-69, 45 USPQ2d at 1164. To determine whether an applicant surrendered particular subject matter, we look to the prosecution history for arguments and amendments made to the claims in an effort to overcome a prior art rejection. Although the recapture rule does not apply in the absence of evidence that the applicant’s amendment of a claim was an admission that the scope of that claim was not patentable, the court may draw inferences from changes in claim scope when other reliable evidence of intent is not available. Deliberate cancellation or amendment of a claim in an effort to overcome a reference strongly suggests that the applicant admits that the scope of the claim before the cancellation or amendment is

unpatentable, but is not dispositive where other evidence in the prosecution history indicates to the contrary. Id. at 1469, 45 USPQ2d at 1164.

Once we determine that an applicant has surrendered the subject matter of the canceled or amended claim, we then determine whether the surrendered subject matter has crept into the reissue claim. Comparing the reissue claim with the canceled claim is one way to do this. If the scope of the reissue claim is the same as or broader than that of the canceled claim, then the patentee is clearly attempting to recapture surrendered subject matter and the reissue claim is, therefore, unallowable. In contrast, a reissue claim narrower in scope escapes the recapture rule entirely.

Id. (citations omitted).

Clement goes on to try to harmonize the opposite holdings in Ball (reissue claims avoided recapture rule) and Mentor (reissue claims did not avoid recapture rule), two cases in which the reissue claims were broader than the canceled or amended claim in some aspects, but narrower in others. In Mentor, the issued claim was directed to a condom catheter and recited an adhesive that was transferred from an outer to an inner surface without turning the condom inside-out. One of the canceled claims recited that the adhesive was transferred from the outer to the inner surface. In making amendments to the claim, the applicant argued that none of the references relied upon showed the transfer of the adhesive from the outer surface to the inner surface. The reissue claim eliminated the limitation that adhesive was transferred from the outer surface to the inner surface and was, therefore, broader than both the issued claim and the canceled claim in this aspect. Although the reissue claim was also narrowed with respect to the canceled claim, it did not escape the recapture rule because these

limitations did not “materially narrow the claim.” Id. at 1469-70, 45 USPQ2d at 1165. Similarly, in Ball, the reissue claims were broader than a canceled claim in one aspect (deletion of the cylindrical configuration limitation) and narrower in another aspect (the feed means element). The prosecution history showed that the “plurality of feedlines” limitation was added in an effort to overcome the prior art, but the cylindrical configuration limitation was neither added in an effort to overcome a prior art rejection nor argued to distinguish the claims from a reference. The Federal Circuit determined that the patentee was not attempting to recapture surrendered subject matter because, on balance, the reissue claim was narrower than the canceled claim with respect to the feed means aspect, the limitation relied upon to overcome the prior art rejection, and broader with respect to the cylindrical configuration limitation, which was not relied upon by the patentee to overcome a prior art rejection. Id.

From the results and reasoning in the Mentor and Ball cases, the Clement court derived the following principles:

(1) if the reissue claim is as broad as or broader than the canceled or amended claim [the surrendered subject matter] in all aspects, the recapture rule bars the claim; (2) if it is narrower [than the surrendered subject matter] in all aspects, the recapture rule does not apply, but other rejections are possible; (3) if the reissue claim is broader [than the surrendered subject matter] in some aspects, but narrower [than the surrendered subject matter] in others, then: (a) if the reissue claim is as broad as or broader in an aspect germane to a prior art rejection, but narrower in another aspect completely unrelated to the rejection, the recapture rule bars the claim; (b) if the reissue claim is narrower in an aspect germane to [a] prior art rejection, and broader in an aspect unrelated to the rejection, the recapture

rule does not bar the claim, but other rejections are possible. Mentor is an example of (3)(a); Ball is an example of (3)(b).

Id.

In applying the above-mentioned test to the facts in that case, the Clement court found that the reissue claim was narrower than the canceled claim with respect to a limitation (brightness) which was added in an effort to overcome a prior art rejection. That narrowing thus related to a prior art rejection. The reissue claim was also found to be broader than the canceled claim in that it eliminated other limitations added to overcome several prior art rejections. That broadening thus related directly to several prior art rejections. The Clement court concluded that, “[o]n balance, reissue claim 49 is broader than it is narrower in a manner directly pertinent to the subject matter that Clement surrendered throughout the prosecution” and thus was impermissible under the recapture rule. Id. at 1471, 45 USPQ2d at 1166.

In Hester Indus. Inc. v. Stein Inc., 142 F.3d 1472,1480-82, 46 USPQ2d 1641, 1648-1649 (Fed. Cir. 1998), the Federal Circuit followed the three-step test set forth in Clement. Following the first step of the Clement test, the Hester court determined that the reissue claims were broader than the original patent claims in that the reissue claims did not include the “solely with steam” and “two sources of steam” limitations found in each of the original patent claims. Next, in accordance with the second step, the court examined whether these broader aspects related to surrendered subject matter. In that patent claim 1, the sole independent claim, issued in substantially the same form in which it was first filed, there was no amendment or cancellation of claims

from which it could be concluded that the applicant had surrendered subject matter. The Hester court, however, concluded that “in a proper case, a surrender can occur through arguments alone.” Id. at 1482, 46 USPQ2d at 1649. With this in mind, the Hester court then determined that the applicant’s repeated arguments during prosecution of the patent application that the “solely with steam” and “two sources of steam” limitations distinguished the original claims from the prior art and were “critical” and “very material” with regard to patentability constituted an admission that these limitations were necessary to overcome the prior art and, hence, resulted in a surrender of “claim scope that does not include these limitations” (i.e., claim 1 without the “solely with steam” and “two sources of steam” limitations). Id.

Having determined that there had been a surrender, the Hester court next set out to determine whether the surrendered subject matter had crept into the reissue claims. Noting that comparing the reissue claim with the canceled or amended claim is one way to do this when the surrender occurs by way of claim amendment or cancellation, the Hester court recognized that such analysis is not available when the surrender is made by way of argument alone. Instead, when the surrender is made by way of argument alone, “we simply analyze the asserted reissue claims to determine if they were obtained in a manner contrary to the arguments on which the surrender is based.” Id. In that none of the reissue claims included either the “solely with steam” or “two sources of steam” limitation, the Hester court determined that the surrendered subject matter,

i.e., cooking other than solely with steam and with at least two sources of steam, had crept into the reissue claims.

While establishing that surrender can occur through argument alone, Hester certainly does not make any attempt to alter the test set forth in Clement for determining whether surrendered subject matter has crept into the claim when the surrender occurs by way of claim amendment or cancellation, that is, comparison of the reissue claim with the canceled or amended claim. In any event, citing Mentor, 998 F.2d at 996, 27 USPQ2d at 1525, Hester recognized that the recapture rule may be avoided in some circumstances where the reissue claims were materially narrowed in respects other than those in which the reissue claims were broadened. In particular,

[i]n the context of a surrender by way of argument, this principle, in appropriate cases, may operate to overcome the recapture rule when the reissue claims are materially narrower in other overlooked aspects of the invention. The purpose of this exception to the recapture rule is to allow the patentee to obtain through reissue a scope of protection to which he is rightfully entitled for such overlooked aspects.

Id. at 1482-83, 46 USPQ2d at 1649-50. Thus, Hester certainly does not support the examiner's per se rule that "[a]fter the addition of a claim limitation to secure allowance of a patent, an attempt to subsequently obtain patent protection by reissuing the patent with one or more claims that do not contain that limitation is impermissible because this is not a [correctable] error" (request, page 3). On the contrary, Hester leaves open the

possibility that such reissue claims may avoid the recapture rule where they are materially narrowed in other respects.

Pannu v. Storz Instruments Inc., 258 F.3d 1366, 1370-71, 59 USPQ2d 1597, 1600 (Fed. Cir. 2001), also fails to provide support for the per se rule which the examiner urges this Board to apply. Pannu expressly endorses the three-step process for applying the recapture rule set forth in Clement and Hester. Specifically, according to Pannu:

[t]he first step is to “determine whether and in what ‘aspect’ the reissue claims are broader than the patent claims.” The second step is to determine whether the broader aspects of the reissued claim related to surrendered subject matter. Finally, the court must determine whether the reissued claims were materially narrowed in other respects to avoid the recapture rule.

Id. at 1371, 59 USPQ2d at 1600 (citations omitted). Thus, while the particular reissue claims in Pannu were held not to avoid the recapture rule, Pannu clearly also leaves open the possibility that reissue claims which have been broadened in an aspect related to surrendered subject matter may avoid the recapture rule if they are materially narrowed in other respects.

We acknowledge that the statement in Pannu that “[o]n reissue, [Pannu] is estopped from attempting to recapture the precise limitation he added to overcome prior art rejections” (id. at 1372, 59 USPQ2d at 1601) may, when viewed in complete isolation, appear to provide limited support for the per se rule which the examiner urges

us to follow. We recognize that such a per se rule would eliminate the need for fact-specific analysis and thus may be administratively convenient for examiners and, indeed, for the Board to apply. We are also reminded, however, that the USPTO has been admonished for trying to extract per se rules from generalized commentary found in cases. See, e.g., In re Ochiai, 71 F.3d 1565, 1572, 37 USPQ2d 1127, 1133 (Fed. Cir. 1995). Accordingly, we decline to extract from the above-quoted language in Pannu a generalized rule that a reissue claim which omits a limitation relied upon during prosecution of the patent application is per se impermissible under the recapture rule, regardless of whether the claim has been materially narrowed in other respects compared to the surrendered subject matter. Rather, we consider that the proper inquiry requires a fact-specific analysis in each case to determine whether the patentee is attempting to recapture by reissue subject matter that was surrendered during the prosecution of the patent application. Further, Pannu makes clear that such analysis is conducted in accordance with the basic test set forth in Clement.¹² The Federal Circuit applied the test set forth in Clement in analyzing the facts in Pannu as follows.

¹² The examiner's statement on page 19 of the request for rehearing that, had the Pannu court applied the Clement test relied on by the original panel in this appeal to the facts in Pannu, the court would have been hard pressed to hold the reissue claims barred by 35 U.S.C. § 251 because reissue claim 1 was not broader than original claim 1 in that application in an aspect germane to the prior art rejection, is not well taken, as it ignores the later surrender of subject matter which was of concern to the court. Specifically, the addition of limitations to later added claim 16 and statements made by Pannu limited claim 16 to exclude an interpretation that did not include a continuous, substantially circular arc. Thus, claim 16 without the argued limitations, such as a continuous, substantially circular arc, was surrendered subject matter in Pannu. The fact that the reissue claim was narrower than another claim (original claim 1) which was also surrendered cannot save the reissue claim from the recapture rule. See Byers, 230 F.2d at 457, 109 USPQ at 57.

Pannu's application was directed to an artificial intraocular lens comprising a round lens called an "optic" that focuses light on the retina, two or more elements called "haptics" that are attached to the optic, and "snag resistant" discs attached at the end of the haptics. In applying the first step of the test set forth in Clement to the facts therein, the Pannu court determined that reissue claim 1 was broader than patent claim 1 with respect to the shape of the haptics, in that the reissue claim eliminated the limitation that the haptics ("elements") define "a continuous, substantially circular arc having a diameter greater than the diameter of said lens body, said arc curved toward said lens circumference."

In order to determine whether the broader aspect of the reissue claim related to surrendered subject matter, the Federal Circuit looked to the prosecution history of the original patent application. A review of the prosecution history revealed that original claims 1-14 presented in the patent application were rejected by the examiner as obvious under 35 U.S.C. § 103 in light of four prior art references. None of the original claims limited the shape of the haptics. In response to that rejection, Pannu filed an amendment canceling claims 1-7 and 10-14, adding new claims 16-22 and amending claims 8 and 9 to depend from claim 16. Independent claim 16 recited the haptics (elements) as "defining a continuous substantially circular arc having a diameter greater than the diameter of the lens body, said arc curved toward said lens circumference." The examiner made amendments to claim 16 setting forth structural details of the

haptics and the amended claim 16 issued as patent claim 1.¹³ The Federal Circuit determined that:

[t]he addition of the “continuous, substantially circular arc” limitation to claim 16 and the statements made by Pannu to the examiner during prosecution of the ‘855 patent limited the claim to exclude an interpretation that did not include a continuous, substantially circular arc. The shape of the haptics was broadened during reissue and was the same subject matter that was surrendered during prosecution.

Pannu, 258 F.3d at 1371, 59 USPQ2d at 1600 (citations omitted). Accordingly, the Federal Circuit concluded that this broadened aspect of the reissue claim related to surrendered subject matter.

The reissue claims were also narrower than both claim 16 in the patent application prior to the examiner’s amendments and patent claim 1, in that the reissue claims changed the recitation that the length of the haptics was “substantially greater” than the width of the haptics to “at least three times greater” than the width of the haptics and added the limitation that the snag resistant means must be “substantially coplanar” with the haptics. The Federal Circuit reasoned that, since the narrowing aspect of the claim was directed to the positioning and dimensions of the snag resistant means and not to the shape of the haptics (the broadened aspect), “the reissued claims

¹³ We note that this amendment results in originally presented claim 16 also being surrendered subject matter. See Clement, 131 F.3d at 1471, 45 USPQ2d at 1166 (applicant abandoned the subject matter of claim 42, as it existed before the examiner’s amendment, because he allowed the examiner to amend it to obtain allowance and no other evidence suggested that there was no intent to abandon it).

were not narrowed in any material aspect compared with their broadening.”¹⁴ Pannu, 258 F.3d at 1372, 59 USPQ2d at 1600-01. The Federal Circuit added that “[f]urthermore, ‘if the patentee is seeking to recover subject matter that had been surrendered during the initial prosecution this flexibility of analysis is eliminated, for the prosecution history establishes the substantiality of the change and estops its recapture.’ Anderson v. Int’l Eng’g & Mfg., Inc., 160 F.3d 1345, 1349, 48 USPQ2d 1631, 1634 (Fed. Cir. 1998).” Pannu, 258 F.3d at 1372, 59 USPQ2d at 1601. We understand this language, consistent with the prior precedent of the Federal Circuit, to mean that, where a patentee is seeking to recover in a reissue claim subject matter broader than that surrendered during prosecution, the mere presence of narrowing limitations in the reissue claim is not necessarily sufficient to save the reissue claim from the recapture rule. In other words, the Federal Circuit rejected a per se rule that any narrowing limitations in a reissue claim that has also been broadened in an aspect related to surrendered subject matter escapes the effect of the recapture rule.

In summary, after considering the examiner’s request for rehearing in light of the cases addressing the reissue recapture rule, we reach the conclusion that the original panel did not err in the earlier decision in this appeal in refusing to apply a per se rule

¹⁴ We note that the district court in the Pannu case determined that the three times greater width limitation and coplanar limitation were contained in or similar to parallel terminology in originally filed claim 1 and remained in a dependent claim throughout prosecution of the patent and thus were not overlooked aspects of the original patent. Moreover, the change from substantially greater to three times greater was not a material alteration, according to the district court. Thus, the district court concluded that neither limitation materially narrowed the claim. Pannu v. Storz Instruments, Inc., 106 F. Supp. 2d 1304, 1308 (S.D. Fla. 2000).

that a reissue claim which omits a limitation relied upon to overcome a prior art rejection in prosecuting the patent is always impermissible under the recapture rule. Rather, the panel was correct in applying the fact-specific analysis set forth in Clement, as discussed above. Moreover, for the reasons set forth infra, applying this analysis to the facts of this case, we reach the same ultimate conclusion that was reached by the panel in the prior decision, namely, that the reissue claims in this case are not precluded by the reissue recapture rule.

The prosecution history of the patent

A copy of claim 1, as originally presented in the patent application (Application No. 08/335,992, filed November 8, 1994) which matured into appellants' original patent, appears in Appendix A to this decision. Original claim 4, which depended indirectly from claim 1, further recited "wherein said retaining structure includes a retaining member mounted in said bore outboard of said magnet for cooperation with said inner end surface to retain said magnet therebetween."

In a first Office action (Paper No. 2), the examiner, inter alia, rejected claims 4-6 and 17 under 35 U.S.C. § 112, second paragraph, as being indefinite, because "it is not clear as to the meaning of 'retaining member ... for cooperation with said inner end surface' since the retaining member is mounted in the bore outboard of the magnet" (page 2). Additionally, the examiner rejected claims 1 and 4, inter alia, under 35 U.S.C. § 103 as being unpatentable over Parsons (U.S. Pat. No. 4,663,998) in view of Clark (U.S. Pat. No. 3,007,504) and Miller (U.S. Pat. No. 2,806,396).

In an amendment filed August 31, 1995 (Paper No. 3), appellants added the following language to the end of the last paragraph of claim 1:

said retaining structure including a discrete retaining member friction fitted in said bore outboard of said magnet, said retaining member and said inner end surface cooperating to retain said magnet therebetween.

A copy of independent claim 1 as so amended is contained in Appendix A to this decision, with the added language shown in italics. According to appellants' remarks on page 4 of that amendment (Paper No. 3), appellants indicated that this amendatory language is clear and definite in reciting cooperation between the retaining member and the inner end surface of the bore to retain the magnet in place, thereby presumably responding to the indefiniteness rejection of claim 4, the subject matter thereof being substantially incorporated into independent claim 1. Additionally, appellants pointed out that:

[a] significant aspect of the invention is the provision of a discrete retaining member which is press-fitted in the bore outboard of the permanent magnet. This permits the use of various sized magnets which do not have to be precisely sized for press-fitting in the bore, thereby avoiding the stress occasioned by the press-fitting operation. It also permits the use of a straight bore which does not have to have special grooves or the like formed therein to accommodate a retaining member [Paper No. 3, page 5].

According to appellants, the above-cited language added to claim 1 more clearly brings out this distinguishing aspect of the invention, which is not disclosed or suggested by the cited references (Paper No. 3, page 5). With respect to claim 6, which depended

from claim 4 and was never the subject of a prior art rejection, appellants stated that the limitation therein that the retaining member is generally bowl-shaped, being convex toward the magnet "affords an additional reason for the allowance of claim 6, since this arrangement is not disclosed or suggested in the art of record" (Paper No. 3, page 6).

In a final rejection (Paper No. 4), the examiner repeated the rejection of claim 1 et al. under 35 U.S.C. § 103. The examiner also repeated the rejection of claims 4-6 and 17 under 35 U.S.C. § 112, second paragraph, but did not apply the rejection under 35 U.S.C. § 112, second paragraph, to claim 1.

In response to the final rejection, appellants filed a second amendment on January 22, 1996 (Paper No. 5) in which the language "said retaining member being generally bowl-shaped and convex toward said magnet,"¹⁵ was added to the last paragraph of claim 1. The claims were thus directed specifically to the embodiment of Figures 4 and 5. A copy of twice amended independent claim 1, with additions made in the second amendment shown in bold and the additions from the first amendment indicated in italics, is contained in Appendix A to this decision.

Appellants stated on page 3 of that amendment (Paper No. 5) that "[a]s thus amended, claim 1 is effectively an independent form of claim 6, which was indicated to be allowable." Appellants' amendment also canceled claims 4-6, 13, 17, 18 and 21.

¹⁵ This limitation was incorporated into claim 1 from claim 6, which had not been subject to a prior art rejection. The amendment also canceled claim 6.

The examiner allowed the patent application without further comment (see Paper No. 7) and the original patent thereon issued on November 26, 1996.

The prosecution history of this reissue application

On July 2, 1998, appellants filed this application for reissue of the original patent. The reissue application included original patent claims 1-14 without amendment and added reissue claims 15-22 thereto.

In a first Office action (Paper No. 2, page 3), the examiner rejected claims 15-22 under 35 U.S.C. § 251 as being an improper recapture of broadened subject matter in the application for the original patent upon which the present reissue is based (the rejection now before us). Additionally, the examiner rejected claim 22 under 35 U.S.C. § 251 as containing new matter not supported by appellants' original patent and under the first paragraph of 35 U.S.C. § 112 as containing subject matter which was not described in the specification of appellants' original patent application in such a way as to reasonably convey to one skilled in the art that the inventors, at the time the patent application was filed, had possession of the claimed invention. According to the examiner, the subject matter not supported by the original patent was the limitation "continuous, closed, non-reentrant outer periphery."

In response to the examiner's new matter rejections of claim 22, appellants filed an amendment (Paper No. 3) to claim 22 deleting the language "and having a continuous, closed, non-reentrant outer periphery" and adding the following limitation:

said retaining member having a continuous outer periphery such that any two points on the periphery can be joined by a straight line segment which does not extend outside the periphery.

In the final rejection (Paper No. 4) in this reissue application, the examiner repeated the recapture rejection but did not repeat the new matter rejections. Copies of reissue claims 15 and 22, the only independent reissue claims involved in this appeal, are contained in Appendix B to this decision, with deletions in comparison to patent claim 1 shown in strikeout and additions with respect to patent claim 1 highlighted by underlining. The italics and bold showing language that was added during prosecution of the patent application has also been retained in the reproduction of reissue claims 15 and 22.

Analysis

In accordance with the first step of the Clement test, we must compare the reissue claims with the patent claims to determine whether and in what “aspect” the reissue claims are broader than the patent claims. Such comparison reveals that each of claims 15 and 22 is broader than patent claim 1 in that the limitations that the body is “cylindrical” and has an “axis,” that the bore is axial and terminates in an inner end surface, that the magnet is a “permanent” magnet, that the bore is of “non-circular cross section,” that the retaining member is “generally bowl shaped and convex toward said magnet” and that the retaining member and inner end surface cooperate to retain the magnet therebetween have been omitted in the reissue claims. The language

“interference fitted” describing the fitting of the retaining member in the bore has also been omitted from the reissue claims. In our opinion, however, this is not in fact a broadening in this aspect, as the reissue claims do retain the limitation that the retaining member is “friction fitted” in the bore from patent claim 1. In that a friction fit is a specific type of interference fit, the additional recitation of the retaining member as being “interference fitted” in the bore did not actually impart any structural limitation to the claim.¹⁶ It thus follows that its omission does not constitute any broadening of the scope of the claim.

Having determined that the reissue claims have been broadened relative to patent claim 1, we must next determine whether those broadenings relate to surrendered subject matter.¹⁷ A review of the prosecution history outlined above reveals that appellants added the language "said retaining member being generally bowl-shaped and convex toward said magnet" to claim 1 in response to the final rejection in order to overcome the prior art rejection based on Parsons in view of Clark and Miller. We thus conclude that appellants, in adding that limitation, conceded that claim 1 prior to that amendment was not patentable, thereby surrendering the subject matter of that claim. Hence, the omission of this limitation in reissue claims 15 and 22 is in an aspect germane to the prior art rejection. The deliberate amendment of claim 1

¹⁶ Original panel determination (page 24) that has not been contested.

¹⁷ The second step of the test set forth in Clement.

in an effort to overcome the prior art rejection is, in our view, an admission that the scope of the claim before the amendment is unpatentable and establishes that subject matter as surrendered subject matter.

The next stage in the inquiry is to compare the rejected reissue claims to the surrendered subject matter to determine in what aspects the reissue claims are broader than the surrendered subject matter and in what aspects the reissue claims are narrower than the surrendered subject matter. The reissue claims are broader than the surrendered subject matter in that the limitations "cylindrical," the body having an axis, the bore being "axial" and terminating at an inner end surface," "permanent," "non-circular" and the retaining member and inner end surface cooperating to retain the magnet therebetween have been omitted. However, these omitted limitations clearly relate to features which were not argued by appellants as distinguishing over the applied prior art and appear to be fully met by Parsons. We thus conclude that these omissions are not germane to a prior art rejection. In fact, the omission of the limitation that the body has an axis is not deemed to be a material broadening, in that any three-dimensional object would meet this limitation.

Next, we must determine if the reissue claims are narrower than the surrendered subject matter. Reissue claim 15 has been narrowed relative to both the surrendered subject matter (claim 1 prior to the amendment after the final rejection) and patent claim 1 in that reissue claim 15 limits the shape of the retaining member as "substantially

covering said outer surface of said magnet.” Reissue claim 22 has likewise been narrowed relative to both the surrendered subject matter and patent claim 1 in that it limits the shape of the retaining member as “having a continuous outer periphery such that any two points on the periphery can be joined by a straight line segment which does not extend outside the periphery.”¹⁸ Since these limitations of claims 15 and 22 define the claimed subject over the applied prior art these limitations are germane to a prior art rejection.

As reissue claims 15 and 22 are both narrower than the surrendered subject matter in an aspect germane to the prior art rejection (i.e., the shape of the retaining member) and broader only in aspects unrelated to the rejection, we reach the same conclusion as set forth on pages 25-26 of the earlier decision of the Board (Paper No. 17) that reissue claims 15 and 22, and hence claims 16-21¹⁹ which depend from reissue claim 15, are narrower than the surrendered subject matter in an aspect germane to the prior art rejection and broader only in aspects unrelated to the rejection. The facts

¹⁸ Unlike the situation in Pannu, the reissue claims before us have been narrowed in the same aspect (i.e., the shape of the retaining member) in which they were broadened with regard to the patent claim 1.

¹⁹ As noted in the earlier decision in this appeal, the examiner's application of the reissue recapture rejection to reissue claim 18 seems illogical, in that reissue claim 18 includes the limitation that the retaining member is "generally bowl-shaped and convex toward said magnet" which is the subject of the examiner's rejection. With regard to footnote 39 on page 21 of the examiner's request, we acknowledge the examiner's invitation to the Board to enter a new ground of rejection of claim 18 under 35 U.S.C. § 251 on the basis that it does not cure the stated error, but we decline to do so.

before us therefore fall into category (3)(b) as described by Clement, 131 F.3d at 1470, 45 USPQ2d at 1165:

In both Mentor and Ball, the relevance of the prior art rejection to the aspects narrowed in the reissue claim was an important factor in our analysis. From the results and reasoning of those cases, the following principles flow: (1) if the reissue claim is as broad as or broader than the canceled or amended claim [the surrendered subject matter] in all aspects, the recapture rule bars the claim; (2) if it is narrower [than the surrendered subject matter] in all aspects, the recapture rule does not apply, but other rejections are possible; (3) if the reissue claim is broader [than the surrendered subject matter] in some aspects, but narrower [than the surrendered subject matter] in others, then: (a) if the reissue claim is as broad as or broader in an aspect germane to a prior art rejection, but narrower in another aspect completely unrelated to the rejection, the recapture rule bars the claim; (b) if the reissue claim is narrower in an aspect germane to [a] prior art rejection, and broader in an aspect unrelated to the rejection, the recapture rule does not bar the claim, but other rejections are possible.

Thus, in accordance with the principles set forth in Clement, the recapture rule does not bar the reissue claims in this case.²⁰

The prosecution history of the patent application in this case does not persuade us that appellants surrendered anything narrower than the subject matter of claim 1 prior to the amendment after final adding the limitation "said retaining member being generally bowl-shaped and convex toward said magnet." See Festo, 122 S.Ct. at 1838,

²⁰ The reissue claims before us are therefore unlike those at issue in Clement, which were both broader and narrower in areas relevant to the prior art rejections and thus did not fall into any of Clement's categories (1), (2), (3)(a) and (3)(b). See Clement, 131 F.3d at 1470, 45 USPQ2d at 1165 ("In [Clement's] case, reissue claim 49 [was] both broader and narrower in areas relevant to the prior art rejections."); id. at 1471, 45 USPQ2d at 1166 ("On balance, [Clement's] reissue claim 49 is broader than it is narrower in a manner directly pertinent to the subject matter that Clement surrendered throughout the prosecution. Even with the additional limitations, [Clement's] claims 50-52 are also broader than they are narrower in a manner directly pertinent to the subject matter that Clement surrendered during prosecution.").

62 USPQ2d at 1711 (a patentee's decision to forego an appeal and submit an amended claim is taken as a concession that the invention as patented does not reach as far as the original claim). Finally, as recognized by Festo²¹, 122 S.Ct. at 1840-41, 62 USPQ2d at 1712-13, claim drafting is an imperfect art. While a narrowing amendment may demonstrate what the claim is not, it may still fail to capture precisely what the claim is. Id. at 1841, 62 USPQ2d at 1712. Moreover, an amendment does not show that an applicant suddenly had more foresight in the drafting of claims than an applicant whose application was granted without amendments having been submitted. Id. In this case, it appears to us that appellants made an error in limiting the shape of the retaining member more narrowly than was required to overcome the prior art rejection, thereby claiming less than he had a right to claim in the patent²², and, in our view, this is the type of error which can be corrected by reissue under 35 U.S.C. § 251. To hold otherwise would controvert the remedial nature of the statute.

²¹ While, as pointed out by the dissent, "[a] patentee's decision to narrow his claims through amendment may be presumed to be a general disclaimer of the territory between the original claim and the amended claim" (Festo, 122 S. Ct. at 1842, 62 USPQ2d at 1713) in the context of prosecution history estoppel when applying the doctrine of equivalents in an infringement action, we are aware of no case, and the dissent has not pointed to any case, which so defined "surrendered subject matter" in the context of the reissue recapture rule. Indeed, as discussed above, the precedent in the area of the reissue recapture rule repeatedly establishes that the narrowing of a claim by amendment constitutes surrender of the amended claim, that is, the claim prior to the amendment. Moreover, in light of the fact that the fourth paragraph of 35 U.S.C. § 251 permits enlargement of the scope of patent claims in reissue within two years of the issue date of the patent, it is quite apparent that the theory of disclaimer through narrowing amendments expressed in Festo cannot be applied to correction of patents through reissue consistent with 35 U.S.C. § 251.

²² See 35 U.S.C. § 251, ¶ 1.

Conclusion

For the foregoing reasons, it is our opinion that the original panel did not err in its earlier decision in concluding that reissue claims 15-22 are not precluded by the recapture rule. As should be apparent from our discussion above, the examiner's request for rehearing has been reviewed and the request granted to the extent of our reconsidering the decision of the earlier panel but denied with respect to changing the result therein. The examiner's rejection of reissue claims 15-22 under 35 U.S.C. § 251 remains REVERSED.

DENIED

GARY V. HARKCOM
Vice Chief Administrative Patent Judge

WILLIAM F. SMITH
Administrative Patent Judge

)
)
)
) BOARD OF PATENT
) APPEALS
) AND
) INTERFERENCES
)
)
)

APPENDIX A

Original independent claim 1 of the '992 application read as follows:

A bit holder comprising:

a cylindrical body having a distal end surface and an axis, said body having formed in said end surface an axial bore terminating at an inner end surface,

a permanent magnet received in said bore and having an outer surface, and

retaining structure in contact with the outer surface of said magnet and interference fitted in said bore to retain said magnet in said bore,

said bore having a portion of non-circular transverse cross section outboard of said retaining structure defining a bit-receiving socket.

Independent claim 1 after Amendment A in the '992 application (additions in italics) :

A bit holder comprising:

a cylindrical body having a distal end surface and an axis, said body having formed in said end surface an axial bore terminating at an inner end surface,

a permanent magnet received in said bore and having an outer surface, and

retaining structure in contact with the outer surface of said magnet and interference fitted in said bore to retain said magnet in said bore,

said bore having a portion of non-circular transverse cross section outboard of said retaining structure defining a bit-receiving socket,

said retaining structure including a discrete retaining member friction fitted in said bore outboard of said magnet,

said retaining member and said inner end surface cooperating to retain said magnet therebetween.

Independent claim 1 after Amendment B and issued as claim 1 of '426 patent (additions in bold):

A bit holder comprising:

a cylindrical body having a distal end surface and an axis, said body having formed in said end surface an axial bore terminating at an inner end surface,

a permanent magnet received in said bore and having an outer surface, and

retaining structure in contact with the outer surface of said magnet and interference fitted in said bore to retain said magnet in said bore,

said bore having a portion of non-circular transverse cross section outboard of said retaining structure defining a bit-receiving socket,

said retaining structure including a discrete retaining member friction fitted in said bore outboard of said magnet,

said retaining member being generally bowl-shaped and convex toward said magnet,

said retaining member and said inner end surface cooperating to retain said magnet therebetween.

APPENDIX B

New claim 15 of reissue application compared to issued claim 1 (deletions in strikeout; additions in underline):

A bit holder comprising:

a ~~eylindrical~~ body having a distal end surface ~~and an axis~~, said body having a bore formed in said end surface ~~an axial bore terminating at an inner end surface~~,

a ~~permanent~~ magnet received in said bore and having an outer surface, and

a discrete retaining structure in contact with the outer surface of said magnet and interference member friction fitted in said bore outboard of said magnet and substantially covering said outer surface of said magnet to retain said magnet in said bore,

~~said bore having a portion of non-circular transverse cross section outboard of said retaining structure member defining a bit-receiving socket;~~

~~said retaining structure including a discrete retaining member friction fitted in said bore outboard of said magnet;~~

~~said retaining member being generally bowl-shaped and convex toward said magnet;~~

~~said retaining member and said inner end surface cooperating to retain said magnet therebetween.~~

New claim 22 of reissue application compared to issued claim 1 (deletions in strikeout; additions in underline):

A bit holder comprising:

a ~~eylindrical~~ body having a distal end surface ~~and an axis~~, said body having a bore formed in said end surface ~~an axial bore terminating at an inner end surface~~,

a ~~permanent~~ magnet received in said bore and having an outer surface, and

a discrete retaining structure in contact with the outer surface of said magnet and interference member friction fitted in said bore outboard of said magnet to retain said magnet in said bore, said retaining member having a continuous outer periphery such that any two points on the periphery can be joined by a straight line segment which does not extend outside the periphery.

~~said bore having a portion of non-circular transverse cross section outboard of said retaining structure member defining a bit-receiving socket;~~

~~said retaining structure including a discrete retaining member friction fitted in said bore outboard of said magnet;~~

~~said retaining member being generally bowl-shaped and convex toward said magnet;~~

~~said retaining member and said inner end surface cooperating to retain said magnet therebetween.~~

BARRETT, Administrative Patent Judge, dissenting, with whom STONER, Chief Administrative Patent Judge, and PAWLIKOWSKI and NAGUMO, Administrative Patent Judges, join.

Introduction

I respectfully dissent because I see an inconsistency in the language of our reviewing court, the U.S. Court of Appeals for the Federal Circuit, regarding what constitutes "surrendered subject matter" that may not be recaptured under the reissue recapture doctrine. This inconsistency is better resolved by the Federal Circuit rather than by an expanded panel of the Board of Patent Appeals and Interferences. Since four of the five reissue recapture cases decided by the Federal Circuit have been inter partes cases, our ex parte decision will not prevent others from challenging the propriety of our decision in an inter partes context. I would reverse the original decision and sustain the examiner's rejection of claims 15-22 under 35 U.S.C. § 251 based on the reissue recapture doctrine and lack of "error."

The issue

The issue is what constitutes "surrendered (i.e., disclaimed) subject matter" that a patentee is estopped from recapturing through reissue under the reissue recapture rule. The particular question sought to be answered is this: if a limitation is added to a claim to overcome a prior art rejection and secure the issuance of a patent, may the

patentee broaden that limitation of the patent claim through reissue, assuming the reissue claim is not otherwise narrowed.

The majority's and examiner's positions

The original decision held that "surrendered subject matter" in a situation involving adding a limitation to overcome a prior art rejection, is the subject matter of the "canceled or amended claim," where a "canceled claim" is a claim which was canceled and replaced by a new claim with the limitation and an "amended claim" is the claim as it existed before it was amended to include that limitation.

The examiner's position in the request for rehearing is that "surrendered subject matter" is any reissue "claim omitting the specific limitation which the record shows was added and/or argued to secure allowance" (page 14) and the fact "that an applicant seeking reissue committed an error in judgment by presenting and arguing a limitation more narrow than was needed in order to secure allowance is not acceptable as being the sort of error for which reissue is available" (page 14). Thus, the examiner concludes that a limitation added and/or argued to overcome a patentability rejection can never be removed.

The majority in this decision on rehearing adheres to the position in the original decision. The majority states that the examiner's position represents a per se rule and that the original panel did not err in not applying a per se rule. The majority finds that

although the reissue claims are broader than the original patent claim in the removal of a claim limitation relating to the shape of the retaining member, they are narrower than the claim that was amended during the initial application in the same aspect of the invention (the shape of the retaining member) and, thus, appellants are not trying to recapture the surrendered subject matter of the canceled or amended claim.

Summary

"Surrendered subject matter" refers to scope of the subject matter that applicant has admitted was not patentable. It is clear that deliberately canceling or amending a claim to overcome prior art is presumptively evidence that the scope of subject matter as broad as or broader than the canceled or amended claim has been surrendered. Most reissue recapture cases can be analyzed under this definition of "surrendered subject matter" because they involve the classic recapture situation of a patentee trying to regain through reissue the subject matter of the canceled or amended claim by removing a limitation that was added to overcome a prior art rejection (usually also adding other limitations that confound the analysis).

The position of this dissent is that "surrendered subject matter" that may not be recaptured through reissue is not limited to the scope of subject matter as broad as or broader than the canceled or amended claims, but is presumed to include subject matter broader than the patent claims in a manner directly related to (1) limitations

added to the claims by amendment (either by amending an existing claim or canceling a claim and replacing it with a new claim with that limitation) to overcome a patentability rejection, or (2) limitations argued to overcome a patentability rejection without amendment of a claim. This prohibition on recapture applies to any narrowing amendment or argument made to satisfy a Patent Act requirement, not just amendments or arguments to avoid prior art. While reissue "error" is liberally construed, amendments and arguments deliberately made to overcome a patentability rejection in order to secure a patent presumptively constitute a "surrender" of subject matter, which is not correctable "error" under 35 U.S.C. § 251. It does not matter whether the examiner was right or wrong in making the rejection. Not only would allowing broadening a limitation added to overcome a patentability rejection impermissibly give the patentee a second chance to prosecute de novo his original application, it would also make members of the public who properly relied on prosecution history, become patent infringers when they do so.

Under this definition of "surrendered subject matter," it is clear that the reissue claims in the present case seek to recapture subject matter surrendered to secure the patent (i.e., subject matter broader than the limitation added by amendment) because they now embrace retaining member shapes intentionally surrendered as a result of amendments made to the claims in order to secure allowance of the claims of the original patent. I would reverse the original decision and sustain the examiner's

rejection of claims 15-22 under 35 U.S.C. § 251 based on the reissue recapture doctrine and lack of "error."

The reissue recapture rule and "error" under 35 U.S.C. § 251

The reissue statute is "based on fundamental principles of equity and fairness, and should be construed liberally." In re Weiler, 790 F.2d 1576, 1579, 229 USPQ 673, 675 (Fed. Cir. 1986). "An attorney's failure to appreciate the full scope of the invention is one of the most common sources of defects in patents." In re Wilder, 736 F.2d 1516, 1519, 222 USPQ 369, 371 (Fed. Cir. 1984). However, "not every event or circumstance that might be labeled 'error' is correctable by reissue." Weiler, 790 F.2d at 1579, 229 USPQ at 675. Indeed, the reissue procedure does not give the patentee the right "to prosecute de novo his original application." Id. at 1582, 229 USPQ at 677.

The recapture rule prevents a patentee from regaining through reissue the subject matter that was surrendered in an effort to obtain allowance of the original claims. In re Clement, 131 F.3d 1464, 1468, 45 USPQ2d 1161, 1164 (Fed. Cir. 1997). As stated in Mentor Corp. v. Coloplast, Inc., 998 F.2d 992, 995, 27 USPQ2d 1521, 1524 (Fed. Cir. 1993):

If a patentee tries to recapture what he or she previously surrendered in order to obtain allowance of original patent claims, that "deliberate withdrawal or amendment . . . cannot be said to involve the inadvertence or mistake contemplated by 35 U.S.C. § 251, and is not an error of the kind which will justify the granting of a reissue patent which includes the matter withdrawn." Haliczer v. United States, 356 F.2d 541, 545, 148 USPQ 565, 569 (Ct. Cl. 1966).

Deliberate surrender of subject matter to secure allowance of the claims "is not the type of correctable 'error' contemplated by the reissue statute." Hester Indus. Inc. v. Stein Inc., 142 F.3d 1472, 1480, 46 USPQ2d 1641, 1647 (Fed. Cir. 1998). While the scope of the claims of the original patent may be enlarged if a reissue patent is applied for within two years, 35 U.S.C. § 251, this does not permit recapture of subject matter surrendered during the initial prosecution. The question on appeal is what constitutes "surrendered subject matter."

Surrendered subject matter

"Surrendered subject matter" refers to the scope of the subject matter that applicant has admitted was not patentable. "Rarely is evidence of the patentee's intent in canceling a claim presented." Ball Corp. v. United States, 729 F.2d 1429, 1436, 221 USPQ 289, 294 (Fed. Cir. 1984). However, the applicant's intent may be inferred from actions in the prosecution history, as stated in Clement, 131 F.3d at 1469, 45 USPQ2d at 1164:

Although the recapture rule does not apply in the absence of evidence that the applicant's amendment was "an admission that the scope of that claim was not in fact patentable," Seattle Box Co. v. Industrial Crating & Packing, Inc., 731 F.2d 818, 826, 221 USPQ 568, 574 (Fed. Cir. 1984), "the court may draw inferences from changes in claim scope when other reliable evidence of the patentee's intent is not available," Ball, 729 F.2d at 1436, 221 USPQ at 294. Deliberately canceling or amending a claim in an effort to overcome a reference strongly suggests that the applicant admits that the scope of the claim before the cancellation or amendment is unpatentable, but it is not dispositive because other evidence in the prosecution history may indicate the contrary. See Mentor,

998 F.2d at 995-96, 27 USPQ2d at 1524-25; Ball, 729 F.2d at 1438, 221 USPQ at 296; Seattle Box Co., 731 F.2d at 826, 221 USPQ at 574 (declining to apply the recapture rule in the absence of evidence that the applicant's "amendment . . . was in any sense an admission that the scope of [the] claim was not patentable"); Haliczer, 356 F.2d at 545, 148 USPQ at 569 (acquiescence in the rejection and acceptance of a patent whose claims include the limitation added by the applicant to distinguish the claims from the prior art shows intentional withdrawal of subject matter); In re Willingham, 48 C.C.P.A. 727, 282 F.2d 353, 354, 357, 127 USPQ 211, 213, 215 (CCPA 1960) (no intent to surrender where the applicant canceled and replaced a claim without an intervening action by the examiner). Amending a claim "by the inclusion of an additional limitation [has] exactly the same effect as if the claim as originally presented had been canceled and replaced by a new claim including that limitation." In re Byers, 43 C.C.P.A. 803, 230 F.2d 451, 455, 109 USPQ 53, 55 (CCPA 1956). [Footnote omitted.]

There is no doubt that the "surrendered subject matter" in the reissue recapture rule includes at least the scope of subject matter as broad as or broader than the canceled or amended claim, either in whole or in a part amended to overcome a prior art rejection. Clement classified the differences between the reissue claims and the original patent claims as either: (1) an aspect germane to a prior art rejection; or (2) an aspect unrelated to the rejection. "[I]f the reissue claim is as broad as or broader than the canceled or amended claim in all aspects, the recapture rule bars the claim . . . [or] if the reissue claim is as broad as or broader [than the canceled or amended claim] in an aspect germane to a prior art rejection, but narrower in another aspect completely unrelated to the rejection, the recapture rule bars the claim." Clement, 131 F.3d at 1470, 45 USPQ2d at 1165. Most reissue recapture cases can be analyzed under the second (broader) test because they involve a patentee trying to eliminate a limitation which was added or argued to overcome a patentability rejection (usually also adding

other limitations that confound the analysis) to get back to the scope of the amended or canceled claim in that aspect. See, e.g., Mentor, 998 F.2d at 995-96, 27 USPQ2d at 1524-25 (Applicant amended the claim and argued that none of the references shows the transfer of adhesive from the outer surface to the inner surface as the sheath is rolled up and then unrolled. The reissue claim eliminated this limitation. "[T]he reissue claims are broader than the original patent claims in a manner directly pertinent to the subject matter surrendered during prosecution. Mentor thus attempted to reclaim what it earlier gave up."); Clement, 131 F.3d at 1470-71, 45 USPQ2d at 1165-66 (Reissue claim eliminated temperature, specific energy, and pH limitations, which had been added during prosecution to distinguish over the prior art, but was narrowed in the area of brightness, which was also related to a prior art rejection. "On balance, reissue claim 49 is broader than it is narrower [as compared to the amended claim] in a manner directly pertinent to the subject matter that Clement surrendered throughout the prosecution."); Hester, 142 F.3d at 1482-83, 46 USPQ2d at 1649-50 (Repeated arguments that "solely with steam" and "two sources of steam" limitations distinguished the original claims from the prior art "surrendered claim scope that does not include these limitations." Added limitations of "spiral conveyance path" and "high humidity steam" did not materially narrow the reissue claims to save them from the recapture rule.); Pannu v. Storz Instruments Inc., 258 F.3d 1366, 1372, 59 USPQ2d 1597, 1600-01 (Fed. Cir. 2001) (In prosecuting the patent, Pannu specifically limited the

shape of the haptics to a "continuous, substantially circular arc" to overcome a prior art rejection. Claim 1 of the reissue eliminated this limitation on the shape of the haptics, but added other limitations not related to the shape of the haptics. "On reissue, he is estopped from attempting to recapture the precise limitation he added to overcome prior art rejections."). Based on these cases, I agree with the examiner's conclusion that limitations added or argued to overcome a patentability rejection may not be completely removed. However, this does not address the present special fact situation where a limitation added to overcome a prior art rejection has been broadened rather than completely eliminated. Therefore, it is necessary to examine the nature of "surrendered subject matter" more closely.

The principles of prosecution history estoppel apply to reissue patents. See Festo Corp. v. Shoketsu Kinzoku Kogyo Kabushiki Co., 234 F.3d 558, 602, 56 USPQ2d 1865, 1899 (Fed. Cir. 2000) (Michel, J., concurring-in-part and dissenting-in-part), vacated and remanded, 122 S. Ct. 1831, 62 USPQ 1705 (2002):

[T]he law of prosecution history estoppel has developed with equal applicability to reissue patents and original patents whose claims were amended during prosecution. By at least 1879, the Supreme Court recognized that the process of obtaining a reissue patent precluded the patentee from recapturing that which he had disclaimed (i.e., surrendered), through the reissuance process.

See also Hester, 142 F.3d at 1481, 46 USPQ2d at 1649 ("Like the recapture rule, prosecution history estoppel prevents a patentee from regaining subject matter surrendered during prosecution in support of patentability."). Surrender can occur in

the same two ways. Compare id. at 1480-81, 46 USPQ2d at 1648 (For reissue recapture: "[A] surrender can occur by way of arguments or claim changes made during the prosecution of the original patent application.") with Loral Fairchild Corp. v. Sony Corp., 181 F.3d 1313, 1322, 50 USPQ2d 1865, 1870-71 (Fed. Cir. 1999) ("Prosecution history estoppel applies to matter surrendered as a result of amendments to overcome patentability rejections, and as a result of argument to secure allowance of a claim." (Internal citation omitted.)). Any decision on reissue recapture should be consistent with the principles of prosecution history estoppel.

"Surrendered subject matter" is defined in connection with prosecution history estoppel in Festo, 122 S. Ct. at 1838, 62 USPQ2d at 1711:

The doctrine of equivalents allows the patentee to claim those insubstantial alterations that were not captured in drafting the original patent claim but which could be created through trivial changes. When, however, the patentee originally claimed the subject matter alleged to infringe but then narrowed the claim in response to a rejection, he may not argue that the surrendered territory comprised unforeseen subject matter that should be deemed equivalent to the literal claims of the issued patent. On the contrary, "[b]y the amendment [the patentee] recognized and emphasized the difference between the two phrases[,] . . . and [t]he difference which [the patentee] thus disclaimed must be regarded as material." Exhibit Supply Co. v. Ace Patents Corp., 315 U.S. 126, 136-137, 62 S.Ct. 513, 86 L.Ed. 736 (1942).

And, id. at 1842, 62 USPQ2d at 1713:

A patentee's decision to narrow his claims through amendment may be presumed to be a general disclaimer of the territory between the original claim and the amended claim. Exhibit Supply, 315 U.S., at 136-137, 62 S.Ct. 513 ("By the amendment [the patentee] recognized and emphasized the difference between the two phrases and proclaimed his abandonment of all that is embraced in that difference").

(The term "amended claim" is used here in the sense of a claim after it is amended, rather than in the sense of a claim before it is amended as in the reissue recapture cases.) The same policy considerations that prevent a patentee from arguing equivalents within the surrendered territory should prohibit the patentee from expressly claiming subject matter within the surrendered territory in reissue. Thus, a narrowing amendment is presumed to surrender broader subject matter that could have been claimed to overcome the patentability rejection. Further, since "[a]rguments made to overcome prior art can equally evidence an admission sufficient to give rise to a finding of surrender," Hester 142 F.3d at 1481, 46 USPQ2d at 1648, arguments are presumed to surrender broader subject matter that could have been claimed instead. Accordingly, the "surrendered subject matter" that may not be recaptured through reissue should be presumed to include subject matter broader than the patent claims in a manner directly related to (1) limitations added to the claims by amendment (either by amending an existing claim or canceling a claim and replacing it with a new claim with that limitation) to overcome a patentability rejection, and (2) limitations argued to overcome a patentability rejection without amendment of a claim. This presumption places the burden of showing that the amendment did not surrender the subject matter sought to be claimed in the reissue on the patentee. Cf. Festo, 122 S. Ct. at 1842, 62 USPQ2d at 1713 ("Just as Warner-Jenkinson held that the patentee bears the burden of proving that an amendment was not made for a reason that would give rise to estoppel, we hold

here that the patentee should bear the burden of showing that the amendment does not surrender the particular equivalent in question.").

This definition is consistent with the statement that, under the recapture rule, "reissue claims . . . broader than the original patent claims in a manner directly pertinent to the subject matter surrendered during prosecution" (emphasis added) are impermissible. Mentor, 998 F.2d at 996, 27 USPQ2d at 1525, cited in Clement, 131 F.3d at 1468, 45 USPQ2d at 1164; Hester, 142 F.3d at 1480, 46 USPQ2d at 1648; Pannu, 258 F.3d at 1371, 59 USPQ2d at 1600. In determining in what "aspect" the reissue claims are broader than the patent claims, "[a]lthough the scope of the claim is the proper inquiry, claim language, including limitations, defines claim scope" (internal citations omitted). Clement, 131 F.3d at 1468; 45 USPQ2d at 1164. Thus, it is proper to look at which limitations are deleted from the patent claims, id., and which limitations are broadened. A limitation in the original patent claims, which was added by amendment or argued to overcome a patentability rejection during the original prosecution, is subject matter "pertinent to the subject matter surrendered during prosecution." If the reissue claim is broader than the original patent claim in this aspect, whether because the limitation is omitted or because the limitation is broader, this is an indication that the patentee is attempting to recapture subject matter surrendered to secure the patent. Since the test in Mentor is based on a comparison of the scope of the reissue claims to the scope of original patent claims, this indicates that

the "surrendered subject matter" includes subject matter broader than the original patent claims in an aspect related to the patentability rejection, and is not limited to subject matter as broad as or broader than the canceled or amended claims.

One uncertainty in the application of the reissue recapture rule is the effect of broadening and narrowing limitations. As stated in Mentor, 998 F.2d at 996, 27 USPQ2d at 1525:¹

Reissue claims that are broader in certain respects and narrower in others [than the original patent claims] may avoid the effect of the recapture rule. If a reissue claim is broader in a way that does not attempt to reclaim what was surrendered earlier, the recapture rule may not apply. However, in this case, the reissue claims are broader than the original patent claims in a manner directly pertinent to the subject matter surrendered during prosecution. Mentor thus attempted to reclaim what it earlier gave up. Moreover, the added limitations do not narrow the [original patent] claims in any material respect compared with their broadening.

(The phrases in brackets are implied from the third sentence and from the context.)

The last sentence suggests that broadening in an aspect germane to patentability may be offset by a material narrowing of the reissue claim in the same aspect. However, as stated in Anderson v. Int'l Eng'g & Mfg., Inc., 160 F.3d 1345, 1349, 48 USPQ2d 1631, 1634 (Fed. Cir. 1998):

In determining whether the scope of a claim has been enlarged, the reexamination practice has shared the body of precedent developed for reissue determinations. Thus this court has held that a change of words

¹ These statements indicate that the reissue recapture principles (1), (2), (3)(a), and (3)(b) in Clement, 131 F.3d at 1470, 45 USPQ2d at 1165, should be measured with respect to the original patent claims instead of the canceled or amended claim of the application.

does not always mean change of scope, and that the question of whether the claims have been materially or substantially enlarged must be determined upon the claim as a whole. See Mentor Corp. v. Coloplast, Inc., 998 F.2d 992, 996, 27 USPQ2d 1521, 1525 (Fed. Cir. 1993) ("Reissue claims that are broader in certain respects and narrower in others may avoid the effect of the recapture rule.") However, in Mentor the court explained that if the patentee is seeking to recover subject matter that had been surrendered during the initial prosecution this flexibility of analysis is eliminated, for the prosecution history establishes the substantiality of the change and estops its recapture. See In re Clement, 131 F.3d 1464, 1468, 45 USPQ2d 1161, 1164 (Fed. Cir. 1997).

Therefore, the overall scope of the reissue claims cannot recapture surrendered subject matter. Narrowing to avoid the recapture rule is further discussed in Hester, 142 F.3d at 1482-83, 46 USPQ2d at 1649-50:

Finally, because the recapture rule may be avoided in some circumstances, we consider whether the reissue claims were materially narrowed in other respects. See, e.g., Mentor, 998 F.2d at 996, 27 USPQ2d at 1525 ("Reissue claims that are broader in certain respects and narrower in others may avoid the effect of the recapture rule."); Clement, 131 F.3d at 1470, 45 USPQ2d at 1165. For example, in Ball the recapture rule was avoided because the reissue claims were sufficiently narrowed (described by the court as "fundamental narrowness") despite the broadened aspects of the claims. 729 F.2d at 1438, 221 USPQ at 296. In the context of a surrender by way of argument, this principle, in appropriate cases, may operate to overcome the recapture rule when the reissue claims are materially narrower in other overlooked aspects of the invention. The purpose of this exception to the recapture rule is to allow the patentee to obtain through reissue a scope of protection to which he is rightfully entitled for such overlooked aspects.

The statement that a reissue claim which is narrower in overlooked aspects may avoid the recapture rule is apparently meant to refer to situations where the patentee erred in not claiming a certain aspect of the disclosed invention. See In re Amos, 953 F.2d 613,

614, 21 USPQ2d 1271, 1272 (Fed. Cir. 1991) (The original claims recited a cam means to lift rollers out of engagement with the workpiece and "were not directed to the alternative of using a computer to control the lifting of the rollers."). However, if the scope resulting from the broadening and narrowing covers subject matter which was surrendered, then the recapture rule should still apply.

If the patentee were allowed to broaden the limitation added to overcome a patentability rejection, this would effectively amount to impermissible de novo prosecution of the application because it amounts to taking out the limitation to go back to the scope of the canceled or amended claim (or the claim that was argued) and then trying to see if a broader limitation would be successful in overcoming the rejection. The reissue procedure does not give the patentee "a second opportunity to prosecute de novo his original application." Weiler, 790 F.2d at 1582, 229 USPQ at 677. In addition, it would be unfair to the public because the broader reissue claim would cover subject matter which members of public who relied on prosecution history would have deemed surrendered. As stated in Mentor, 998 F.2d at 996, 27 USPQ2d at 1525:

Error under the reissue statute does not include a deliberate decision to surrender specific subject matter in order to overcome prior art, a decision which in light of subsequent developments in the marketplace might be regretted. It is precisely because the patentee amended his claims to overcome the prior art that a member of the public is entitled to occupy the space abandoned by the patent applicant. Thus, the reissue statute cannot be construed in such a way that competitors properly relying on prosecution history, become patent infringers when they do so. In this case, Mentor narrowed its claims for the purpose of obtaining allowance in the original prosecution and it is now precluded from recapturing what it earlier conceded.

See also Hester, 142 F.3d at 1481, 46 USPQ2d at 1648-49 (the same reasoning binds the patentee to deliberate assertions made in order to obtain allowance of the original patent claims over the prior art). While a patentee can file for a broadening reissue within two years, the public is entitled to rely on prosecution history to indicate those limitations which have been surrendered and cannot be regained through reissue.

The majority notes that 35 U.S.C. § 251, fourth paragraph, clearly places the public on notice that the scope of claims of a patent may be broadened in a reissued patent applied for within two years from the grant of a patent. Nevertheless, the public is entitled to rely on the law that any broadening within two years is subject to the reissue recapture rule.

Like the court in In re Doyle, 293 F.3d 1355, 1363-64, 63 USPQ2d 1161, 1168 (Fed. Cir. 2002), the majority here observes that the public is protected from the effect of broadening by the intervening rights provisions of 35 U.S.C. § 252, second paragraph. In Doyle, the court held that inadvertent failure to present a claim broad enough to read on—or link—two or more groups of claims subject to a restriction requirement, is an error correctable by reissue. By contrast, in the present situation, the patentee has gone back and undone those amendments deliberately presented during prosecution of the original patent to secure allowance. In such an instance, the defense of intervening rights is poor consolation for accused infringers who rely on prosecution history estoppel under the reissue recapture rule to practice surrendered

subject matter and for their attorneys who advise them. Such accused infringers must bear the substantial expenses related to the lawsuit or licensing of a reissue patent which should not have been granted. Moreover, intervening rights only apply where there has been "substantial preparation," which must be proved by costly court litigation, and is based on "such terms as the court deems equitable for the protection of investments made or business commenced before the grant of the reissue." Therefore, relief is expensive and uncertain. Intervening rights is not an excuse for allowing recapture.

The majority states that applicants who use a continuing application are not constrained by the reissue recapture rule and that imposing the per se rule urged by the examiner would push applicants to file continuing applications to pursue broader claims which does not afford the safeguards of the reissue statutes. Continuation practice and the policy interface between continuation practice and reissue are not at issue.

Patentability

The Supreme Court in Festo agreed with the Federal Circuit that prosecution history estoppel is not limited to amendments made to avoid the prior art, but "a narrowing amendment made to satisfy any requirement of the Patent Act may give rise to estoppel." Festo, 122 S. Ct. at 1839, 62 USPQ2d at 1711-12. There is no reason why this holding should not also apply in the context of reissue recapture.

Inconsistency with other cases

Admittedly, certain language in the cases more readily supports the majority's and appellants' position that "surrendered subject matter" is defined by the scope of the subject matter of the canceled or amended claims and that if a reissue claim is narrower than the canceled or amended claim, as a whole or in the aspect germane to the prior art rejection, the recapture rule does not apply. See Ball, 729 F.2d at 1436, 221 USPQ at 295 (The recapture rule does not bar the patentee from acquiring, through reissue, "claims that are narrower in scope than the canceled claims."); Clement, 131 F.2d at 1470, 45 USPQ2d at 1165 ("[I]f [the reissue claim] is narrower in all aspects [than the canceled or amended claim], the recapture rule does not apply, but other rejections are possible . . . [or] if the reissue claim is narrower in an aspect germane to prior art rejection [than the canceled or amended claim], and broader in an aspect unrelated to the rejection, the recapture rule does not bar the claim, but other rejections are possible."). Older cases expressly say that an added limitation may be broadened in reissue, see In re Richman, 409 F.2d 269, 274-75, 161 USPQ 359, 363 (CCPA 1969), although these cases are more generous than modern cases about correctable "error," and the issue of "surrendered subject matter" does not seem to have been raised in these cases.

Nevertheless, in my opinion, Mentor, Hester, and Pannu support the definition of "surrendered subject matter" as presumptively including the scope of subject matter

broader than the limitation added or argued to overcome a patentability rejection, consistent with the statements in Festo. The reissue recapture principles (1), (2), (3)(a), and (3)(b) in Clement, 131 F.3d at 1470, 45 USPQ2d at 1165, should be measured with respect to the claims of the original patent instead of the canceled or amended claim of the application that matured into the patent. Deliberately surrendered subject matter is not correctable "error" under 35 U.S.C. § 251; thus, amending too narrowly is not an "error." While the outcomes in Mentor, Hester, and Pannu can be rationalized as consistent with the classic recapture situation of the reissue claims entirely removing a limitation which was added or argued to overcome a prior art rejection, I see the language in those cases about reissue claims broader than patent claims in an aspect related to a patentability rejection being impermissible under the reissue recapture rule, as an obstacle to the majority's decision. I think the Federal Circuit should be the entity to clarify what is meant by "surrendered subject matter," which includes the question of "error" under § 251.

Application to facts

The prosecution history is summarized by the majority. The essential facts relate to claiming of the retaining member.

Application of the recapture rule is a three-step process. The first step is to "determine whether and in what 'aspect' the reissue claims are broader than the patent claims." Clement, 131 F.3d at 1468, 45 USPQ2d at 1164. Reissue claims 15 and 22

are broader than original patent claim 1 in the following ways: (1) the limitation of claim 1 that the body is a "cylindrical body" with an "axis" is omitted; (2) the limitation of claim 1 that the bore is an "axial bore terminating at an inner end surface" is omitted; (3) the limitation of claim 1 that the bore has a portion of "non-circular cross section" is omitted; (4) the limitation that the magnet is a "permanent" magnet is omitted; (5) the limitation of claim 1 that "said retaining member and said inner end surface [of the bore] cooperating to retain said magnet therebetween" is omitted; and (6) the limitation of claim 1 of "said retaining member being generally bowl-shaped and convex toward said magnet" has been replaced with the broader limitation "retaining member . . . substantially covering said outer surface of said magnet" in claim 15 and with the broader limitation "said retaining member having a continuous outer periphery such that any two points on the periphery can be joined by a straight line segment which does not extend outside the periphery" in claim 22. The limitations of claim 1 that the retaining structure is "interference fitted" in the bore and "friction fitted" in the bore have been changed to just "friction fitted" in the bore in reissue claims 15 and 22, which, I agree with the majority, does not constitute a broadening of the scope of the claim. Reissue claims 15 and 22 are not narrower than original patent claim 1 in any way.

"The second step is to determine whether the broader aspects of the reissue claims relate to surrendered subject matter." Id. at 1468-69, 45 USPQ2d at 1164. The omitted limitations in (1), (2), (3), and (4) were in claim 1 as originally filed in the application and, thus, were not added to overcome a prior art rejection; nor were the

limitations argued to distinguish over the prior art. Thus, these limitations do not relate to an aspect germane to a prior art rejection and are not presumed to be surrendered subject matter. The reissue recapture rule is not triggered by their removal. See Clement, 131 F.3d at 1470, 45 USPQ2d at 1165 (the reissue recapture rule only applies where a reissue claim is as broad as or broader in an aspect germane to a prior art rejection). Limitation (5) was added to claim 1 by amendment primarily to overcome an indefiniteness rejection and the majority does not consider this to relate to surrendered subject matter.² Limitation (6), "said retaining member being generally bowl-shaped and convex toward said magnet," was present in original dependent claim 6 in the patent application, which was not rejected over prior art. The limitation was added to original claim 1 and argued to define over the prior art and, thus, is an aspect related to surrendered subject matter.

The final step is to "determine whether the [reissue claims are] materially narrowed in other respects to avoid the recapture rule." Hester, 142 F.3d at 1482-83, 46 USPQ2d at 1649-50; Clement, 131 F.3d at 1470, 45 USPQ2d at 1165." Pannu, 258 F.3d at 1371, 59 USPQ2d at 1600. The limitation "said retaining member being generally bowl-shaped and convex toward said magnet" in patent claim 1, which was added to overcome a prior art rejection, has been replaced with the limitation "retaining member . . . substantially covering said outer surface of said magnet" in claim 15 and

² While I believe that an amendment to overcome any kind of patentability rejection can lead to reissue recapture by comparison to the prosecution history estoppel analysis of Festo, this issue has not been briefed and will not be addressed.

with the limitation "said retaining member having a continuous outer periphery such that any two points on the periphery can be joined by a straight line segment which does not extend outside the periphery" in claim 22. The majority characterizes these new limitations as broader descriptions of the shape of the retaining member. It does appear that the new reissue limitations are generic descriptions of shape and that the omitted limitation, "said retaining member being generally bowl-shaped and convex toward said magnet," is one species of shape. The majority finds that the reissue claims have been narrowed in the same aspect in which they were broadened (i.e., the shape of the retaining member) and, therefore, the reissue claims do not recapture the subject matter of the amended claim.

I agree that the majority's decision is not inconsistent with the tests set out under cases such as Ball and Clement, and that appellants were entitled to rely on Ball since it has never been overruled or qualified in this regard. However, under the Festo definition of "surrendered subject matter" as including subject matter broader than the limitation that was added or argued to overcome a patentability rejection, the reissue claims clearly try to recapture surrendered subject matter. Since the limitation "retaining member . . . substantially covering said outer surface of said magnet" in claim 15 and the limitation "said retaining member having a continuous outer periphery such that any two points on the periphery can be joined by a straight line segment which does not extend outside the periphery" in claim 22 are acknowledged to be broader than the limitation "said retaining member being generally bowl-shaped and

convex toward said magnet" in patent claim 1, and since the reissue claims are not narrower than patent claim 1 (as opposed to original application claim 1 before it was amended) in any aspect related to shape, the reissue claims recapture surrendered subject matter related to the shape of the retaining member. For example, reissue claims 15 and 22 cover flat or annular retaining members which were not covered under original patent claim 1.³ "It is precisely because the patentee amended his claims to overcome prior art that a member of the public is entitled to occupy the space abandoned by the patent applicant. Thus, the reissue statute cannot be construed in such a way that competitors, properly relying on prosecution history, become patent infringers when they do so." Mentor, 998 F.2d at 996, 27 USPQ2d at 1525. The public was entitled to rely on the prosecution history to determine that appellants had surrendered the right to claim any shape broader than "said retaining member being generally bowl-shaped and convex toward said magnet" in patent claim 1. The reissue claims are barred by the reissue recapture rule. Appellants' amendment in the original application to narrow claim 1 more than needed to overcome the prior art is not correctable "error" under the reissue statute. "Error under the reissue statute does not include a deliberate decision to surrender specific subject matter in order to overcome

³ Appellants also filed divisional Application 08/593,396 of the present application, which issued as U.S. Patent 5,603,248, and reissued as RE 36,797. A preliminary amendment filed concurrently with the filing of the divisional included an amendment reciting "said retaining structure including a discrete, flat, imperforate retaining member." This is evidence that appellants admitted the scope of the original claim 1 was unpatentable and that appellants were claiming a different shape of the retaining member. It is not apparent how the divisional shows that appellants were not admitting that a broader claim than patent claim 1 was not patentable.

prior art, a decision which in light of subsequent developments in the marketplace might be regretted." Mentor, 998 F.2d at 996, 27 USPQ2d at 1525.

I would reverse the original decision and sustain the examiner's rejection of claims 15-22 under 35 U.S.C. § 251 based on the reissue recapture doctrine and lack of correctable "error."

BRUCE H. STONER, JR.)	
Chief Administrative Patent Judge)	
)	
)	
)	
)	
LEE E. BARRETT)	
Administrative Patent Judge)	
)	
)	
)	
)	BOARD OF PATENT
)	APPEALS
BEVERLY A. PAWLIKOWSKI)	AND
Administrative Patent Judge)	INTERFERENCES
)	
)	
)	
MARK NAGUMO)	
Administrative Patent Judge)	

Appeal No. 2001-0790
Application No. 09/110,145

73

SEYFARTH SHAW
55 EAST MONROE STREET
SUITE 4200
CHICAGO, IL 60603-5803