

**UNITED STATES  
PATENT AND TRADEMARK OFFICE**



# Professional Responsibility and Practice Before the USPTO

William R. Covey

Deputy General Counsel for Enrollment and Discipline and  
Director Office of Enrollment and Discipline  
United States Patent and Trademark Office

UNITED STATES  
PATENT AND TRADEMARK OFFICE



# Proposed Annual Active Patent Practitioner Fee

- August 1, 2018: Notice of Public Hearing regarding proposed patent fee adjustments pursuant to AIA Section 10. (83 Fed. Reg. 37,487)
  - Patent Public Advisory Committee (PPAC) public hearing - September 6, 2018.
  - Notice of Proposed Rulemaking (NPRM) scheduled for late summer 2019.
- Discount for those who complete voluntary CLE.
- Discount for paying electronically.

	<u>Filed Electronically</u>	<u>Paper Filing</u>
<u>With CLE Certification</u>	\$240	\$310
<u>Without CLE Certification</u>	\$340	\$410

# Register of Patent Practitioners

<https://oedci.uspto.gov/OEDCI/>

**uspto** [About Us](#) [Jobs](#) [Contact Us](#)

## Office of Enrollment and Discipline

[USPTO Home](#) > [About Us](#) > [Organizational Offices](#) > [Office of the General Counsel](#) > [Office of Enrollment and Discipline \(OED\)](#)  
> [Patent Practitioner Home Page](#) >

 [Print](#)

**Persons Recognized to Practice in Patent Matters**  [Go](#)

## Patent Practitioner Home Page

The listings contain contact information for attorneys and agents with licenses to practice before the US Patent and Trademark Office.

Currently, there are **11749 active agents** and **34725 active attorneys**. All searches reflect current information available to OED.

Information concerning a practitioner's status as an attorney is based on records provided to the Office of Enrollment and Discipline and might not reflect the practitioner's status in a State Bar. Individuals interested in a practitioner's status in a State Bar should contact that State Bar for specific information.

 [Patent Practitioner Search](#)

 [Registered Practitioner Sign In Page \(OEDIS-CI\)](#)

# Law School Clinic Certification Program

- Allows students in a participating law school's clinic program to practice before the USPTO under the strict guidance of a Law School Faculty Clinic Supervisor.
- The OED Director grants participating law students limited recognition to practice before the USPTO.
- Signed into law on December 16, 2014.
- 62 law schools actively participate:
  - 26 trademark only,
  - 6 patent only,
  - 30 both.
- Added 32 new clinic programs in recent 2016-2017 expansion.
- For additional information:
  - <https://www.uspto.gov/learning-and-resources/ip-policy/public-information-about-practitioners/law-school-clinic-1>



# Patent Pro Bono Program

- Assists financially under-resourced independent inventors and small businesses.
  - Section 32 of the AIA calls on the USPTO to work with and support IP law associations to establish *pro bono* programs.
  - 50 state coverage achieved and maintained since August 2015.
- Promote small business growth and development.
- Help ensure that no deserving invention lacks patent protection because of a lack of money for IP counsel.
- Inventors and interested attorneys can navigate the USPTO website to find links to their regional program: <http://www.uspto.gov/probonopatents>.
- USPTO *Pro Bono* Contacts:
  - John Kirkpatrick - [john.kirkpatrick@uspto.gov](mailto:john.kirkpatrick@uspto.gov), 571-270-3343.
  - Grant Corboy – [grant.corboy@uspto.gov](mailto:grant.corboy@uspto.gov), 571-270-3102.
  - Tara Ho – [tara.ho@uspto.gov](mailto:tara.ho@uspto.gov), 571-272-9962.



# OED – Diversion Program

- A 2016 ABA Commission on Lawyer Assistance Programs and Hazelden Betty Ford Foundation published a study of 13,000 currently-practicing attorneys and found the following:
  - Between 21-36% qualify as problem drinkers
  - Approximately 28% struggle with some level of depression
  - 19% struggle with anxiety
  - 23% struggle with stress
  - Other difficulties include social alienation, work addiction, sleep deprivation, job dissatisfaction, and complaints of work-life conflict.
- USPTO announced diversion as two-year pilot program on November 3, 2017.

# OED Discipline: Grievances and Complaints

- An investigation of possible grounds for discipline may be initiated by the receipt of a grievance. *See* 37 C.F.R. § 11.22(a).
- Grievance: “a written submission from any source received by the OED Director that presents possible grounds for discipline of a specified practitioner.” 37 C.F.R. § 11.1.
- Common Sources of Information:
  - External to USPTO: Clients, Colleagues, Others.
  - Internally within USPTO: Patent Corps, Trademark Corps, Other.
- Duty to report professional misconduct:
  - 37 C.F.R. § 11.803.



# OED Discipline: Grievances and Complaints

- If investigation reveals that grounds for discipline exist, the matter may be referred to the Committee on Discipline to make a probable cause determination. *See* 37 C.F.R. § 11.32.
- If probable cause is found, OED Director may file a complaint under 37 C.F.R. § 11.34. *See* 37 C.F.R. § 11.32.
- 37 C.F.R. § 11.34(d) specifies that the timing for filing a complaint shall be within one year after the date on which the OED Director receives a grievance.
- 37 C.F.R. § 11.34(d) also states that no complaint may be filed more than 10 years after the date on which the misconduct occurred.

# Other Types of Discipline

- Reciprocal discipline. 37 C.F.R. § 11.24.
  - Based on discipline by a state or federal program or agency.
  - Usually conducted on documentary record only.
- Interim suspension based on conviction of a serious crime. 37 C.F.R. § 11.25.

# OED Discipline: Grievances

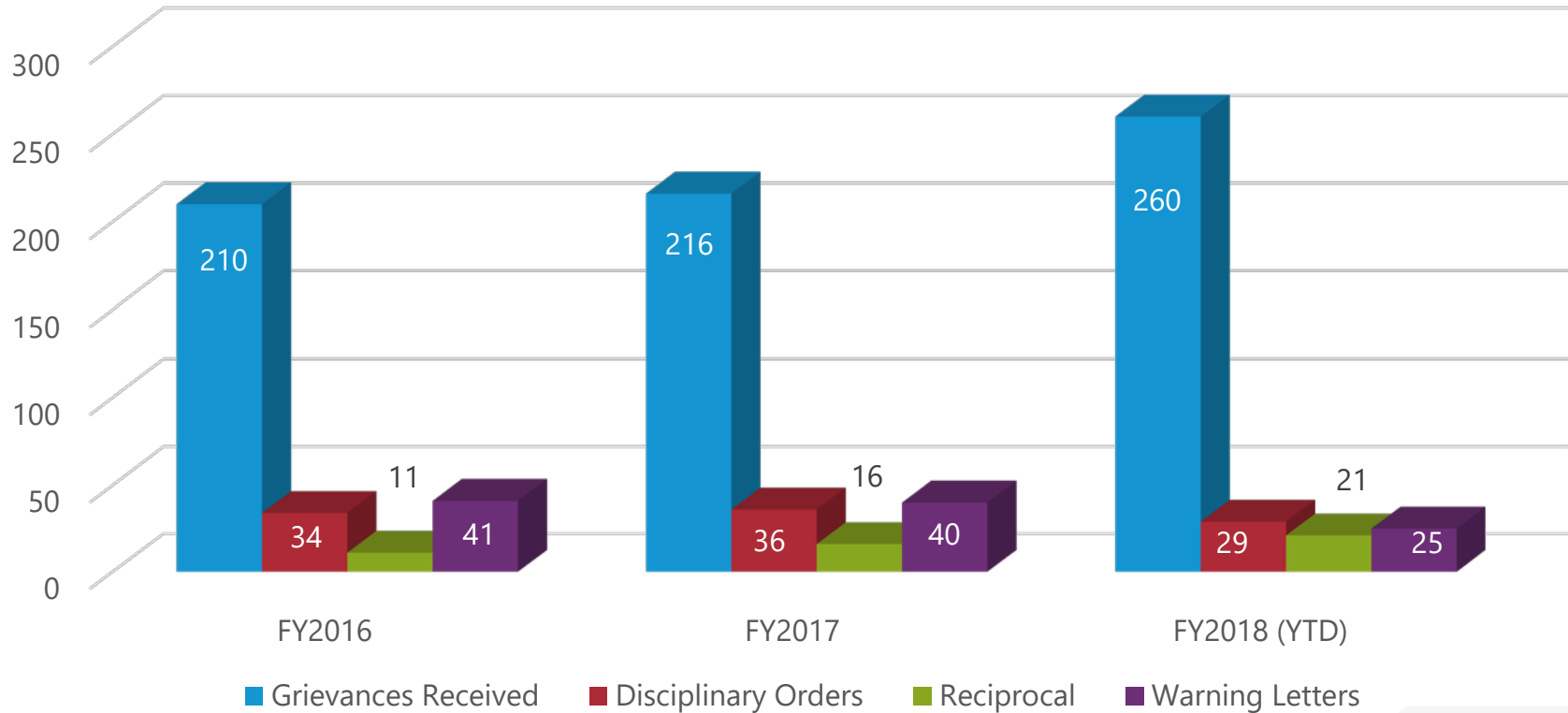

# Office of Enrollment and Discipline

## Discussions of Select Case Law

# Conflicts of Interest

- 1) Third-Party Referrers
- 2) Concurrent/Former Client Conflicts

# Conflicts of Interest – Third Parties

- ***In re Gray***, Proceeding No. D2017-02 (USPTO Feb. 22, 2017).
  - Exclusion on consent.
- ***In re Virga***, Proceeding No. D2017-14 (USPTO Mar. 16, 2017).
  - 5-year suspension
- ***In re Mikhailova***, Proceeding No. D2017-18 (USPTO Jun. 16, 2017).
  - 20 month suspension.
- ***In re Montgomery***, Proceeding No. D2018-02 (Jan. 10, 2018).
  - 4-year suspension.
- ***In re Lavenda***, Proceeding No. D2018-21 (Feb. 27, 2018).
  - Exclusion on consent.

# Conflict of Interest – Third Parties

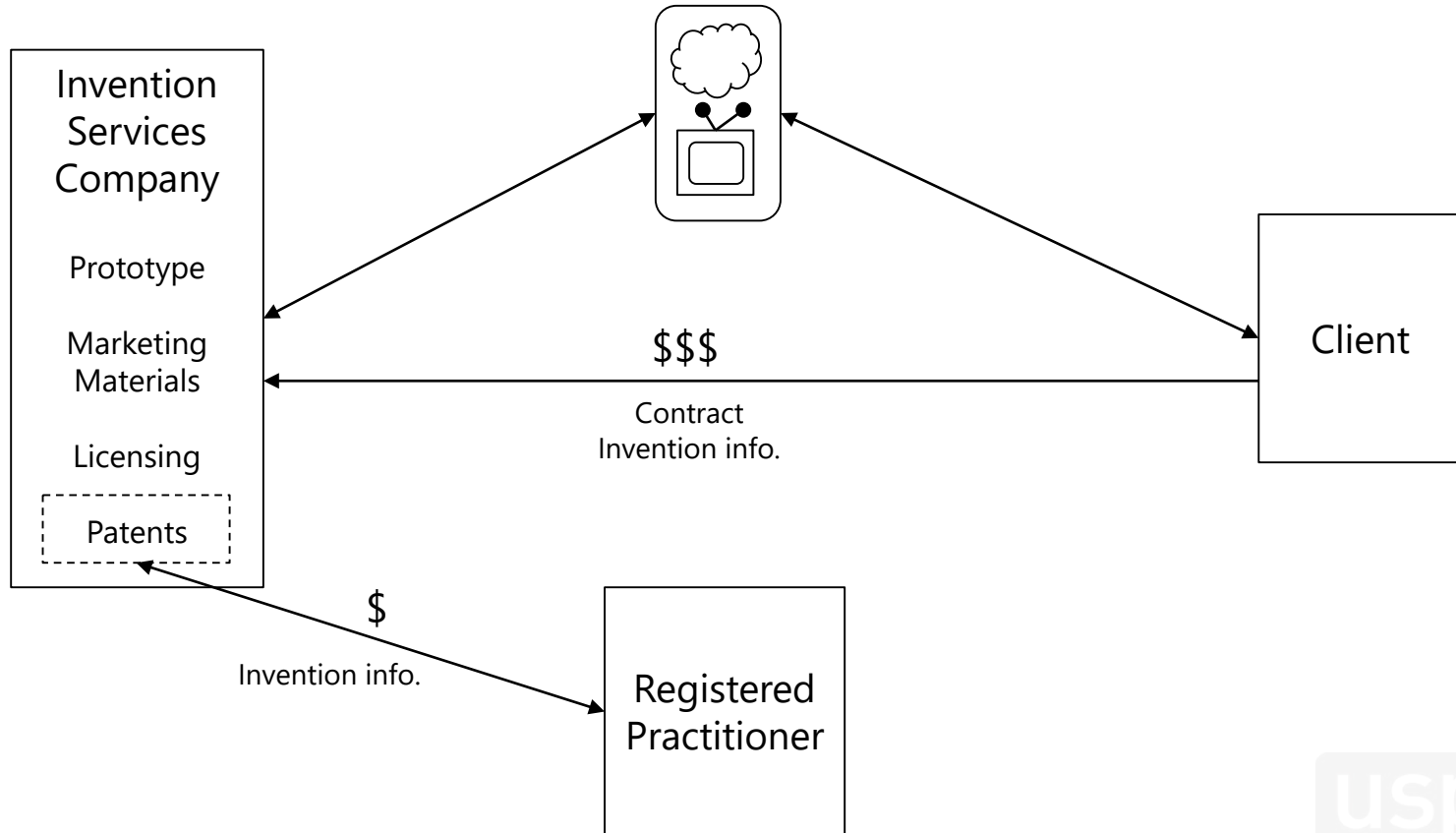

# Conflicts of Interest

## 37 C.F.R. § 11.107(a)

...a practitioner shall not represent a client if the representation involves a concurrent conflict of interest.

A concurrent conflict of interest exists if:

- (1) The representation of one client will be **directly adverse** to another client; or
- (2) There is a **significant risk** that the representation of one or more clients will be **materially limited** by the practitioner's responsibilities to another client, a former client or a third person or by a personal interest of the practitioner.



# Conflicts of Interest

## 37 C.F.R. § 11.107(b)

Notwithstanding the existence of a concurrent conflict of interest under paragraph (a) of this section, a practitioner may represent a client if:

- (1) The practitioner reasonably believes that the practitioner will be able to provide competent and diligent representation to each affected client;
- (2) The representation is not prohibited by law;
- (3) The representation does not involve the assertion of a claim by one client against another client represented by the practitioner in the same litigation or other proceeding before a tribunal; and
- (4) **Each affected client gives informed consent, confirmed in writing.**

# Conflicts of Interest

## 37 C.F.R. § 11.108(f)

A practitioner shall not accept compensation for representing a client from one other than the client unless:

- (1) The client gives **informed consent**;
- (2) There is no interference with the practitioner's **independence of professional judgment** or with the client-practitioner relationship; and
- (3) Information relating to representation of a client is protected as required by §11.106.

## 37 C.F.R. § 11.504(c)

A practitioner shall not permit a person who recommends, employs, or pays the practitioner to render legal services for another to direct or regulate the practitioner's **professional judgment** in rendering such legal services.

# Scope of Representation

## 37 C.F.R. § 11.102

(a) Subject to paragraphs (c) and (d) of this section, a practitioner shall abide by a client's decisions concerning the objectives of representation and, as required by §11.104, **shall consult with the client as to the means by which they are to be pursued.** A practitioner may take such action on behalf of the client as is impliedly authorized to carry out the representation. A practitioner shall abide by a client's decision whether to settle a matter.

\* \* \*

(c) A practitioner may limit the scope of the representation if the limitation is reasonable under the circumstances **and the client gives informed consent.**

# Conflicts of Interest

Where a non-practitioner third party refers inventors to registered practitioners to provide the patent legal services purchased by inventors from the third party, **the practitioner may not merely fill a purchase order. Instead, the practitioner must independently assess the suitability of the sought-after patent protection and communicate his or her assessment to the inventor**...By remaining passive and merely providing the patent legal services purchased by the referred inventor, a practitioner may be found to have formed a *de facto* partnership with the non-practitioner and also may be assisting the company to commit the unauthorized practice of law.

- ***In re Mikhailova***, Proceeding No. D2017-18 (USPTO June 16, 2017).

# Conflicts of Interest

...under circumstances where a non-practitioner third party refers inventors to registered practitioners to provide the patent legal services purchased by inventors from the third party, **the inventor would likely be unable to provide the requisite informed consent absent a meaningful discussion with the practitioner that fully informs the referred inventor of the actual and potential conflicts of interest arising from the fee arrangement between inventor, third party, and practitioner.**

Additionally, **the practitioner must communicate the scope of the representation and the basis or rate of the fee and expenses for which the client will be responsible**, see 37 C.F.R. § 11.105(b), and shall obtain informed consent whenever limiting the scope of the representation (e.g., such as when only preparing and filing an application and not prosecuting it), see 37 C.F.R. § 11.102(c).

- ***In re Mikhailova***, Proceeding No. D2017-18 (USPTO June 16, 2017).

# Conflicts of Interest

Under circumstances where a non-practitioner third party regularly refers inventors to registered practitioners to provide the patent legal services purchased by inventors from the third party, **practitioners may unwittingly violate the fee-sharing prohibition if the practitioner does not know the amount the inventor has paid to the third party for patent legal services.** If the entire amount received by the third party for the practitioner's compensation is not distributed to the practitioner and any undistributed compensation held by the third party is not returned to the inventor, then the practitioner has likely impermissibly shared fees with a non-practitioner. **Hence, a practitioner is reasonably expected to question carefully the inventor and the referring non-practitioner third party about the amounts being charged to the inventor for the patent legal services to ensure the entire amount is remitted to the practitioner.**

- *In re Mikhailova*, Proceeding No. D2017-18 (USPTO June 16, 2017).

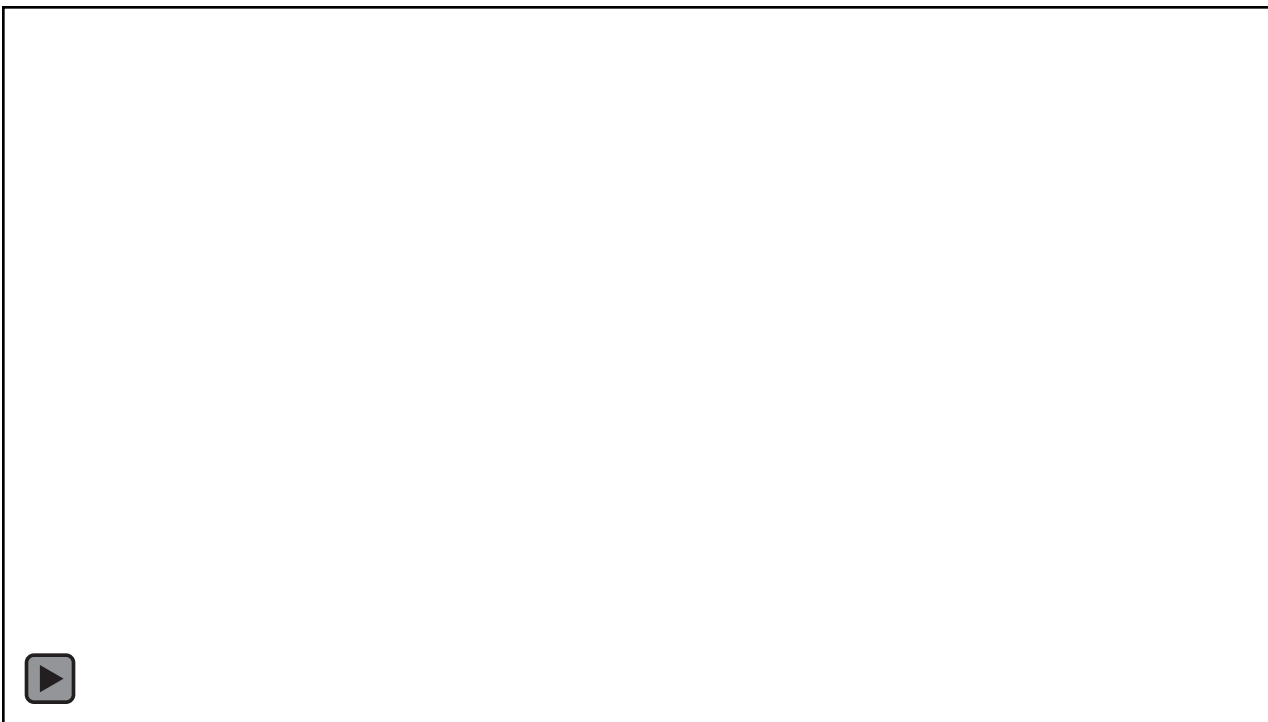

# Conflicts of Interest - Clients

- ***In re Radanovic***, Proceeding No. D2014-29 (USPTO Dec. 16, 2014).
  - Public Reprimand.
- ***In re Ramberg***, Proceeding No. D2017-12 (USPTO Feb. 14, 2017).
  - Public reprimand.
- ***In re Blackowicz***, Proceeding No. D2015-13 (USPTO May 11, 2015).
  - 30-day suspension.
- ***In re Newman***, Proceeding No. D2015-14 (USPTO Nov. 12, 2015).
  - 30-day suspension.



# Conflicts of Interest

37 C.F.R. § 11.109(a)

A practitioner who has formerly represented a client in a matter shall not thereafter represent another person in the same or a substantially related matter in which that person's interests are materially adverse to the interests of the former client **unless the former client gives informed consent, confirmed in writing.**

# Conflicts of Interest

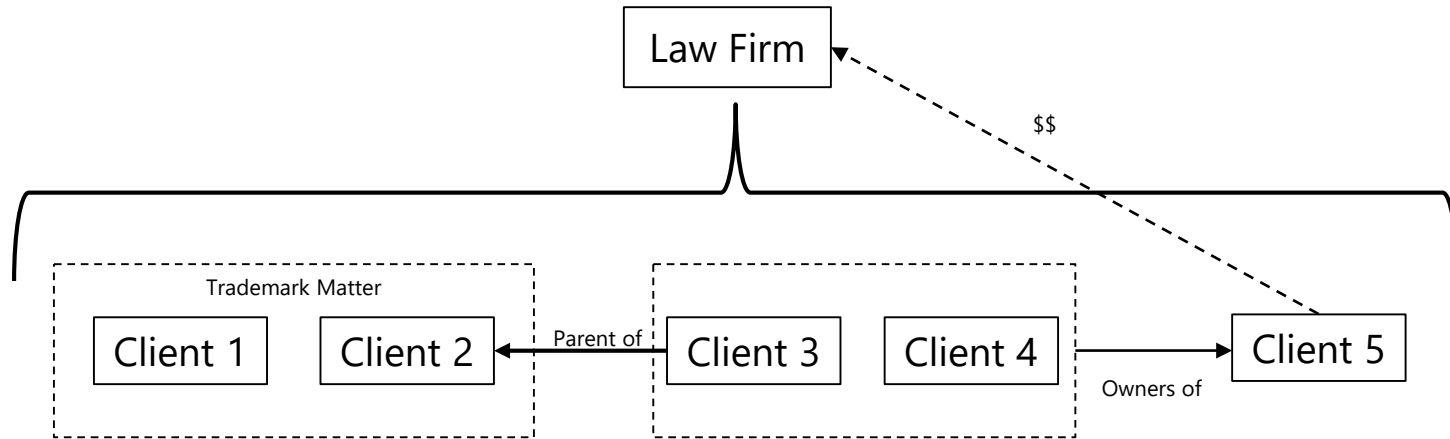

# Supervisory Practitioners

## 37 C.F.R. § 11.501 Responsibilities of partners, managers, and supervisory practitioners:

- (a) A practitioner who is a partner in a law firm, and a practitioner who individually or together with other practitioners possesses comparable managerial authority in a law firm, shall make **reasonable efforts** to ensure that the firm has in effect measures giving **reasonable assurance** that all practitioners in the firm conform to the USPTO Rules of Professional Conduct.
- (b) A practitioner having direct supervisory authority over another practitioner shall make reasonable efforts to ensure that the other practitioner **conforms to the USPTO Rules of Professional Conduct**.
- (c) A practitioner shall be responsible for another practitioner's violation of the USPTO Rules of Professional Conduct if:
- (1) The practitioner orders or, with knowledge of the specific conduct, **ratifies the conduct** involved; or
  - (2) The practitioner is a partner or has comparable managerial authority in the law firm in which the other practitioner practices, or has direct supervisory authority over the other practitioner, and **knows of the conduct at a time when its consequences can be avoided or mitigated but fails to take reasonable remedial action**.

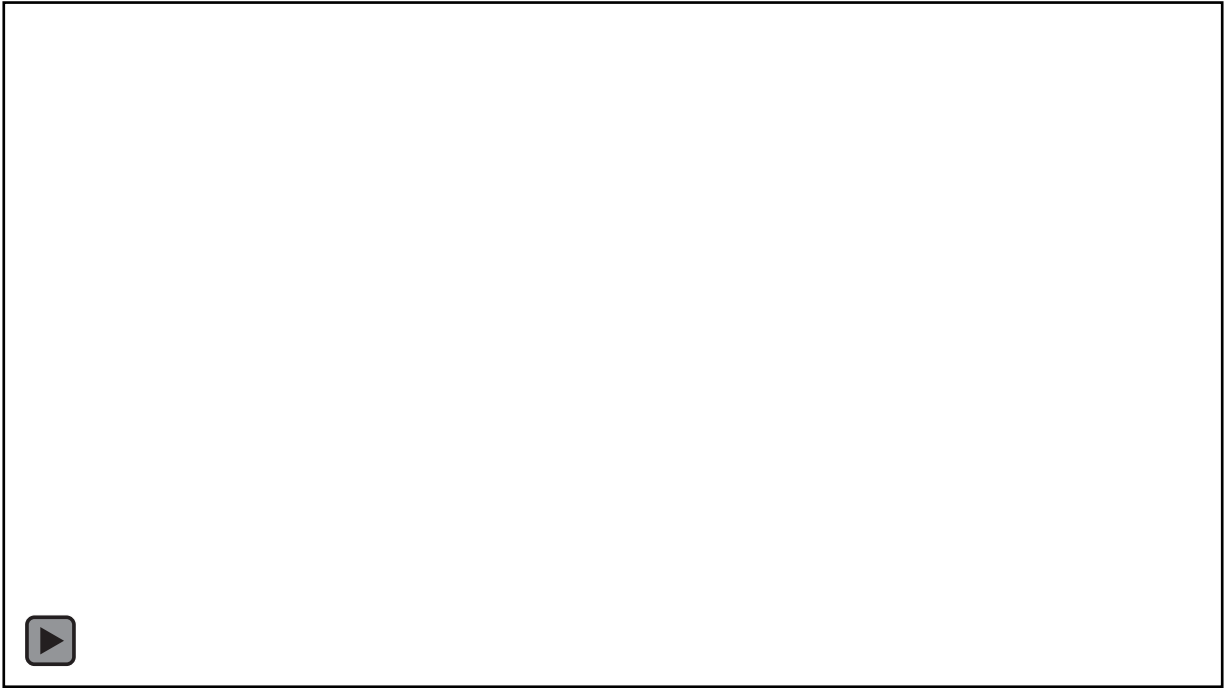

# Disreputable or Gross Misconduct

*In re Schroeder*, Proceeding No. D2014-08  
(USPTO May 18, 2015).

- Patent Attorney:
  - Submitted unprofessional remarks in two separate Office action responses.
  - Remarks were ultimately stricken from application files pursuant to 37 C.F.R. § 11.18(c)(1).
  - Order noted that behavior was outside of the ordinary standard of professional obligation and client's interests.
  - Aggravating factor: has not accepted responsibility or shown remorse for remarks.
- Default: 6-month suspension.
- Rule highlights:
  - 37 C.F.R. § 10.23(a) – Disreputable or gross misconduct.
  - 37 C.F.R. § 10.89(c)(5) – Discourteous conduct before the Office.
  - 37 C.F.R. § 10.23(b)(5) – Conduct prejudicial to the administration of justice.
  - 37 C.F.R. § 11.18 – Certification upon filing of papers.



# Neglect/Candor

*In re Kroll*, Proceeding No. D2014-14 (USPTO March 4, 2016).



# Neglect/Candor

*In re Kroll*, Proceeding No. D2014-14  
(USPTO March 4, 2016).

- Patent attorney:
  - Attorney routinely offered (and charged \$) to post client inventions for sale on his website.
  - Did not use modern docket management system.
  - Attorney failed to file client's application, but posted the invention for sale on his website.
  - Attorney filed application 20 months after posting on the website.
- Aggravating factors included prior disciplinary history.
- Received two-year suspension.
- Rule highlights:
  - 37 C.F.R. § 10.23(a) – Disreputable or gross misconduct.
  - 37 C.F.R. § 11.18(b) – Certification upon filing of papers.
  - 37 C.F.R. § 10.77(c) – Neglect.

# Neglect/Candor

*In re Kroll*, Proceeding No. D2014-14 (USPTO March 4, 2016).

- 37 C.F.R. § 11.18(b): By presenting to the Office...any paper, the party presenting such paper, whether a practitioner or non-practitioner, is certifying that—
  - (1) All statements made therein of the party's own knowledge are true, all statements made therein on information and belief are believed to be true...
  - (2) To the best of the party's knowledge, information and belief, **formed after an inquiry reasonable under the circumstances**,
    - (i) The paper is not being presented for any improper purpose, such as to harass someone or to cause unnecessary delay or needless increase in the cost of any proceeding before the Office;
    - (ii) The other legal contentions therein are warranted by existing law or by a nonfrivolous argument for the extension, modification, or reversal of existing law or the establishment of new law;
    - (iii) The allegations and other factual contentions have evidentiary support or, if specifically so identified, are likely to have evidentiary support after a reasonable opportunity for further investigation or discovery; and
    - (iv) The denials of factual contentions are warranted on the evidence, or if specifically so identified, are reasonably based on a lack of information or belief.



# Deceit/Conduct Prejudicial to the Administration of Justice

*In re Kroll*, Proceeding No. D2016-23 (USPTO March 4, 2016).

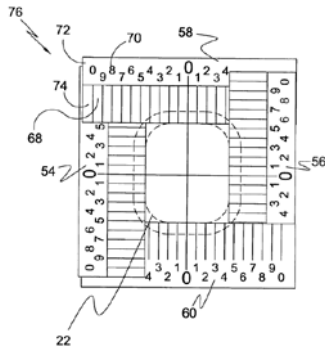
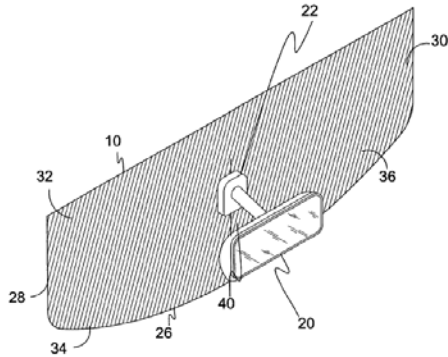

1st Application

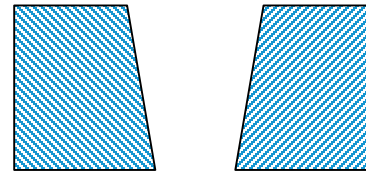
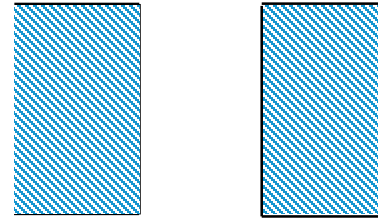

2nd Application

# Deceit/Conduct Prejudicial to the Administration of Justice

*In re Kroll*, Proceeding No. D2016-23 (USPTO March 4, 2016).

- Patent attorney:
  - Offered money back guarantee to obtain patent for client's invention.
  - Amended claims during prosecution of 1<sup>st</sup> application to add specific features without authorization from client.
    - 1<sup>st</sup> application issues as a patent.
  - Filed 2<sup>nd</sup> application on another aspect of clients invention. Again offers money back guarantee.
    - The prior patent presented an obstacle to broad protection in the 2<sup>nd</sup> application.
  - Prior to filing 2<sup>nd</sup> application, attorney inserts additional features into specification without informing client.
  - During prosecution, the additional features are added to claims to overcome rejection using prior patent without client authorization.
  - On multiple occasions, attorney offered to pay – and did pay – client not to file an ethics grievance.
- Aggravating factors included prior disciplinary history.
- Excluded from practice.

# Deceit/Conduct Prejudicial to the Administration of Justice

*In re Kroll*, Proceeding No. D2016-23 (USPTO March 4, 2016).

On the attempt to avoid ethical complaint via payment:

Respondent additionally violated his duty to the public, the legal system, and the legal profession by prejudicing the administration of justice through his efforts to conceal his client's grievances through quid pro quo arrangements. As noted above, his actions to avoid full restitution and to hide his malfeasance are contrary to the public's interest in promoting transparency regarding an attorney's professionalism; undermine the legal profession's ability to self-police its membership; and, frustrate the administration of justice by preventing the proper adjudication of ethical complaints.

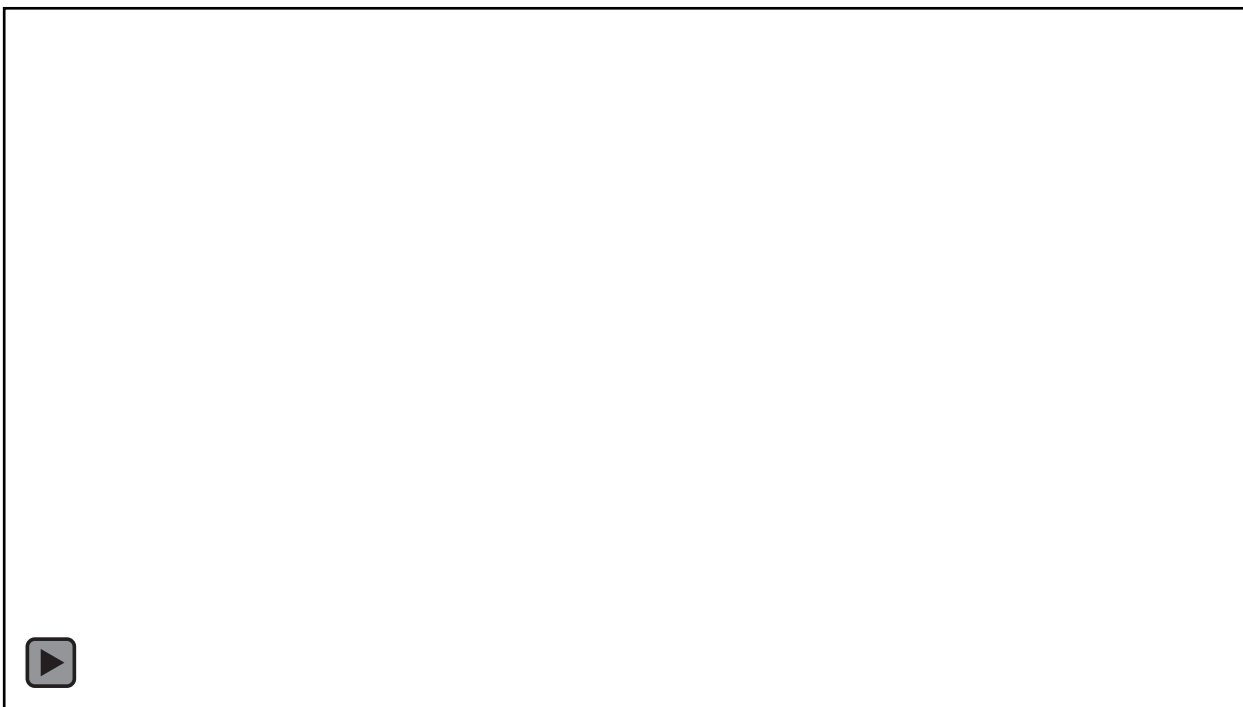

# Misrepresentation/UPL

*In re Swyers*, Proceeding No. D2016-20  
(USPTO January 26, 2017).

- Disciplinary complaint alleged:
  - TM attorney established The Trademark Company, PLLC.
  - Permitted non-attorneys to practice TM law for him with little to no supervision.
  - Multiple fraudulent or digitally manipulated TM specimens were filed with USPTO.
  - Failed to deposit client advance funds into a client trust account.
  - Failed to cooperate with OED investigation.
- Exclusion on consent.
- Rule highlights:
  - 37 C.F.R. § 10.23(b)(5) – Conduct prejudicial to the administration of justice.
  - 37 C.F.R. § 10.23(c)(2)(ii) – Giving false or misleading information to the Office
  - 37 C.F.R. § 10.47(a) & (c) – Aiding the unauthorized practice of law.

# Communication/Cooperation/UPL

***In re Terzo***, Proceeding No. D2016-35 (USPTO November 2, 2016).

- Exclusion on consent of registered patent attorney.
- Disciplinary complaint alleged:
  - Took over the representation of a suspended practitioner's trademark clients without informing the clients.
  - Did not consult with the clients prior to filing their applications.
  - Relied on a "Trademark Questionnaire" filled out by the clients.
    - Did not determine the accuracy of the information set forth in the questionnaire.
  - Directed non-practitioner assistants to provide clients with legal advice.
    - Directed one paralegal to prepare, sign his (Terzo's) name, and file TM applications without direct supervision.
    - Allowed paralegal to approve examiner's amendments.
    - Directed non-lawyer assistants to provide patent legal advice and legal services to clients.
  - Required advance payment for services; deposited payments into operating account before earning fees or incurring expenses.
  - Did not cooperate with the disciplinary investigation.

# Communication/Cooperation/UPL

*In re Terzo*, Proceeding No. D2016-35 (USPTO November 2, 2016).

- 37 C.F.R. § 11.104 Communication:

(a) A practitioner shall:

- (1) Promptly inform the client of any decision or circumstance with respect to which the client's informed consent is required by the USPTO Rules of Professional Conduct;
- (2) Reasonably consult with the client about the means by which the client's objectives are to be accomplished;
- (3) **Keep the client reasonably informed about the status of the matter;**
- (4) Promptly comply with reasonable requests for information from the client; and
- (5) Consult with the client about any relevant limitation on the practitioner's conduct when the practitioner knows that the client expects assistance not permitted by the USPTO Rules of Professional Conduct or other law.

(b) **A practitioner shall explain a matter to the extent reasonably necessary to permit the client to make informed decisions regarding the representation.**

# Communication/Cooperation/UPL

*In re Terzo*, Proceeding No. D2016-35 (USPTO November 2, 2016).

- 37 C.F.R. § 11.115 Safekeeping property:

(a) A practitioner shall hold property of clients or third persons that is in a practitioner's possession in connection with a representation **separate from the practitioner's own property...**

- 37 C.F.R. § 11.505 Unauthorized practice of law:

**A practitioner shall not practice law in a jurisdiction in violation of the regulation of the legal profession in that jurisdiction, or assist another in doing so.**

- 37 C.F.R. § 11.801 Registration, recognition, and disciplinary matters:

An applicant for registration or recognition to practice before the Office, or a practitioner in connection with an application for registration or recognition, or a practitioner in connection with a disciplinary or reinstatement matter, shall not:

(a) Knowingly make a false statement of material fact; or

(b) Fail to disclose a fact necessary to correct a misapprehension known by the person to have arisen in the matter, **fail to cooperate with the Office of Enrollment and Discipline in an investigation of any matter before it**, or knowingly fail to respond to a lawful demand or request for information from an admissions or disciplinary authority, except that the provisions of this section do not require disclosure of information otherwise protected by §11.106.



# Duty of Candor

***In re Tendler***, Proceeding No. D2013-17 (USPTO Jan. 8, 2014).

- Patent attorney filed Rule 131 declaration re: reduction to practice with USPTO.
- Soon after, attorney learned that the inventor did not review the declaration and that declaration contained inaccurate information.
- Respondent did not advise the Office in writing of the inaccurate information and did not fully correct the record in writing.
- District court held resultant patent unenforceable due to inequitable conduct, in part, because of false declaration. *Intellect Wireless v. HTC Corp.*, 910 F. Supp. 1056 (N.D. Ill. 2012). Federal Circuit upheld.
  - 1<sup>st</sup> requirement is to expressly advise PTO of existence of misrepresentation, stating specifically where it resides.
  - 2<sup>nd</sup> requirement is that PTO be advised of misrepresented facts, making it clear that further examination may be required if PTO action may be based on the misrepresentation.
  - It does not suffice to merely supply the Office with accurate facts without calling attention to the misrepresentation.
- 4 year suspension (eligible for reinstatement after 2 years).

# Decisions Imposing Public Discipline Available In FOIA Reading Room

- ▶ <http://e-foia.uspto.gov/Foia/OEDReadingRoom.jsp>
  - ▶ In the field labeled "Decision Type," select "Discipline" from the drop down menu.
    - To retrieve all discipline cases, click "Get Info" (not the "Retrieve All Decisions" link).
- ▶ Official Gazette for Patents
  - [http://www.uspto.gov/news/og/patent\\_og/index.jsp](http://www.uspto.gov/news/og/patent_og/index.jsp) Select a published issue from the list, and click on the "Notices" link in the menu on the left side of the web page.

# Contacting OED

For Informal Inquiries, Contact OED at  
571-272-4097

THANK YOU

