

Report to Congress  
January 2012

# Report on the Prior User Rights Defense

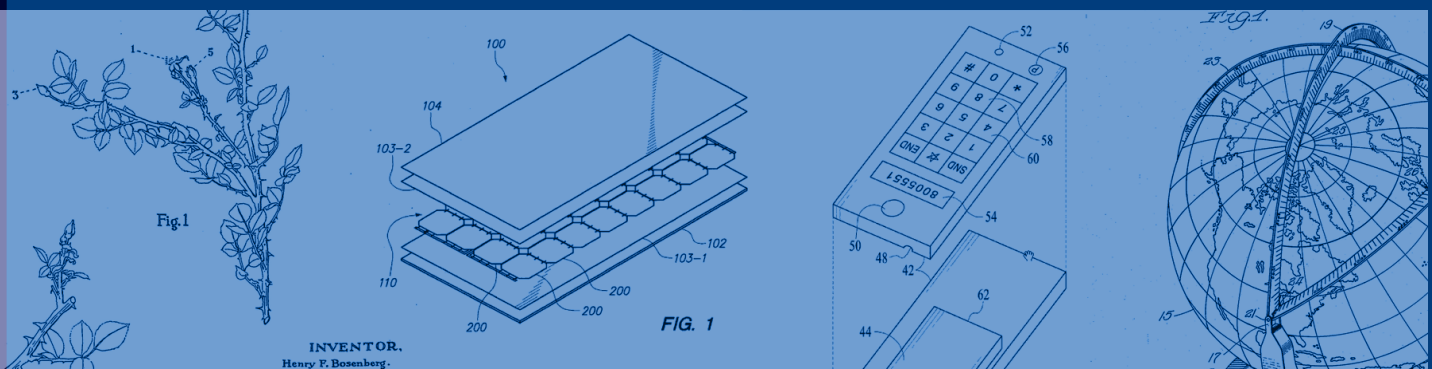

prepared by

The United States Patent and Trademark Office

in consultation with

The Office of the United States Trade Representative

The United States Department of Justice

The United States Department of State

**uspto**.GOV



**The United States Patent and Trademark Office**  
an agency of the Department of Commerce

**REPORT ON THE PRIOR USER RIGHTS DEFENSE**

---

**UNITED STATES PATENT AND TRADEMARK OFFICE**

**David J. Kappos**

Under Secretary of Commerce for Intellectual Property and  
Director of the United States Patent and Trademark Office

**Teresa Stanek Rea**

Deputy Under Secretary of Commerce for Intellectual Property and Deputy Director of the  
United States Patent and Trademark Office

Inquiries concerning this report should be directed to: Paul Salmon at (571) 272-9300 or  
Paul.Salmon@uspto.gov

The United States Patent and Trademark Office acknowledges and thanks the Office of the United States Trade Representative, the Department of Justice, and the Department of State for their collaboration and valuable contributions to this report. The Office also thanks the hearing participants and members of the public who submitted comments.

# REPORT ON PRIOR USER RIGHTS

## UNITED STATES PATENT AND TRADEMARK OFFICE

### CONTENTS

<i>Section Title</i>	<i>Page</i>
<b>EXECUTIVE SUMMARY</b> .....	1
<b>I. INTRODUCTION</b> .....	5
<b>II. BACKGROUND</b> .....	9
<b>III. DISCUSSION</b> .....	10
A. Comparison of Prior Use Provisions in Industrialized Countries .....	10
B. Impact of Prior User Rights on Innovation, Start-up Enterprises, Small Businesses, Individual Inventors and Universities .....	28
C. Analysis of Legal and Constitutional Issues with Placing Trade Secret Law in Patent Law ....	41
D. Analysis of Whether a First-to-File Patent System Creates a Need for Prior User Rights .....	47
<b>IV. CONCLUSION</b> .....	53
<b>Appendix A:</b> Prior Use Defense in the American Inventors Protection Act of 1999 .....	55
<b>Appendix B:</b> Prior Use Defense in the <i>Leahy-Smith America Invents Act</i> .....	56
<b>Appendix C:</b> List of Parties Providing Testimony and/or Comments .....	58
<b>Appendix D:</b> Comparison Chart of Studied Countries .....	60

## EXECUTIVE SUMMARY

The Leahy-Smith America Invents Act (AIA), signed into law on September 16, 2011, represents the most substantial overhaul of U.S. patent law in generations. Among the fundamental changes the AIA makes to the U.S. patent system—and a central feature of the new law—is the transition from a first-to-invent to a first-to-file system of awarding patents.

The AIA also expands the “prior user rights” defense to infringement and broadens the classes of patents that are eligible for the new limited prior user rights defense. Appropriate delimited prior user rights protect third parties who can demonstrate that they were commercially using the an invention for at least one year prior to the filing date of a patent application relative to such invention. U.S. law already provided a prior user rights defense that was limited to patents directed to methods of conducting business. The AIA, by contrast, extends the prior user rights defense to patents covering all technologies, not just business methods. At the same time, the AIA includes several limitations and exceptions to the prior user rights defense, including a prohibition against license, assignment or transfer of the defense, other than in connection with an assignment or transfer of the entire business to which the defense relates; the defense is geographically limited to cover only those sites where the invention was used before the critical date; and there is an explicit exception to the defense for patents owned by or assigned to universities or affiliated technology transfer organizations. These limitations and exceptions to the prior user rights defense address the equitable interests of patentees, universities and affiliated organizations.

In response to concerns expressed during the legislative debate about the impact of an expanded prior user rights defense on the patent system, and innovation more generally, Congress mandated the United States Patent and Trademark Office (USPTO) to produce a report detailing its findings and recommendations on the operation of prior user rights in the industrialized world. Specifically, Congress directed the USPTO to examine and report on the following issues:<sup>1</sup>

- (A) A comparison between patent laws of the United States and the laws of other industrialized countries, including members of the European Union and Japan, Canada, and Australia.
- (B) An analysis of the effect of prior user rights on innovation rates in the selected countries.
- (C) An analysis of the correlation, if any, between prior user rights and start-up enterprises and the ability to attract venture capital to start new companies.

---

<sup>1</sup> Leahy-Smith America Invents Act, Pub. L. No. 112-29, § 3(m), 125 Stat. 284, 292 (2011).

- (D) An analysis of the effect of prior user rights, if any, on small businesses, universities, and individual inventors.
- (E) An analysis of legal and constitutional issues, if any, that arise from placing trade secret law in patent law.
- (F) An analysis of whether the change to a first-to-file patent system creates a particular need for prior user rights.

Pursuant to this mandate, the USPTO held a public hearing and solicited comments from interested parties to complement its own independent research on the issue of prior user rights. Additionally, the USPTO obtained input from the Office of the United States Trade Representative (USTR), the Department of Justice (DOJ), and the Department of State (DOS). The USPTO received 29 comments from a broad spectrum of foreign and domestic stakeholders, including industry organizations, universities, bar associations, and individuals. Most of the comments supported the AIA's prior user rights defense, though several expressed concerns about the effect such a defense could have on, *inter alia*, patent valuation and the prompt disclosure of new innovations. In this respect, a number of comments discussed the interaction between patents and trade secrets as a business strategy for protecting inventions. While a few comments took a view that prior user rights may have the unintended consequence of promoting secrecy over disclosure in a manner that could be detrimental to the patent system, many others noted that the ability to maintain trade secrets is vital to American competitiveness and job growth, and that a limited prior user right defense is an appropriate complement to a first-to-file system.

On the basis of these comments, our own research, and input provided by USTR, DOJ, and DOS, the USPTO finds that:

1. The AIA strikes the right balance by limiting the prior user rights defense to those parties that can prove commercial use at least one year prior to the filing date of the patent application by clear and convincing evidence.
2. The scope of the prior user rights defense includes limitations on the type of continued activities, the transfer of the personal rights, and the enforcement of said right, such that the patentee's rights are not unjustly impinged and the university community may benefit, since the defense is not available in patent actions by universities.

3. There is not substantial evidence that prior user rights as established in the AIA will have a negative impact on innovation.
4. There is no substantial evidence showing that prior user rights as established in the AIA will have a disproportionately negative impact on venture-capital investments to small businesses and start-ups.
5. There is an insufficient basis to recommend a change to the scheme chosen by Congress with respect to the application of prior user rights to universities.
6. There is no substantial evidence that the limited prior user right defense as established by the AIA will have a negative impact on small businesses or independent inventors.
7. A prior use defense to patent infringement is both Constitutional and lawful and the defense is consistent with the Constitution and Supreme Court precedent recognizing that trade secret law and patent law can, and do, legally co-exist in the United States, and indeed have co-existed since our Constitution was created.
8. Trade secret protection is of considerable value to United States businesses and the United States economy, and as such, there are compelling economic and policy justifications for providing a prior user rights defense to patent infringement.
9. Providing limited prior user rights in a first-inventor-to-file system addresses the inherent inequity such a system creates between an earlier commercial user of the subject matter and a later patentee. A prior user rights defense is pro-manufacturing and pro-jobs, as it rewards businesses that put new technology promptly into commercial use, and provides protection for early commercial use when challenged by the later filing of patent applications by other entities.
10. Because the availability of a prior user rights defense to patent infringement is a fundamental aspect of many patent regimes throughout the industrialized world, there is a strong preference that United States businesses be afforded the same advantages in terms of prior use protections in the United States that their competitors enjoy abroad.

Accordingly, pursuant to the congressional mandate under AIA<sup>2</sup>, the USPTO recommends the following:

1. The prior user rights defense provisions set forth in the AIA are generally consistent with those of major trading partners and need not be altered at this time.
2. The prior user right defense under the AIA should be maintained with no change at the present time because there is no substantial evidence that it will have a negative impact on innovation, venture funding, small businesses, universities, or independent inventors.
3. The USPTO should reevaluate the economic impacts of prior user rights as part of its 2015 report to Congress on the implementation of the AIA, when better evidence as to these impacts might be available.
4. United States patent law should provide for a prior user rights defense as an appropriate balance between trade secret protection and patent law, which legally co-exist to provide competitive advantages for United States businesses.
5. United States patent law should provide for a prior user rights defense to patent infringement in order to address a systemic inequity inherent in a first-inventor-to-file system and to ensure United States businesses are (i) able to protect their investments in the event of a later issued patent, and (ii) placed on similar footing as competitors in other jurisdictions.

---

<sup>2</sup> *Id.*

## I. INTRODUCTION

On September 16, 2011, President Obama signed into law the AIA,<sup>3</sup> a landmark piece of legislation representing the most comprehensive overhaul of United States patent law in generations.<sup>4</sup> The AIA ensures that the United States patent system fulfills the Constitutional imperative to “promote the Progress of Science and useful Arts”<sup>5</sup> in light of 21<sup>st</sup> century economic and business challenges, while also maintaining American leadership in the global innovation marketplace.<sup>6</sup> To this end, the AIA streamlines our patent system and improves the quality of patents granted in the United States to minimize unnecessary litigation costs.<sup>7</sup>

For example, the AIA enhances protection available for non-patented innovations and trade secret assets. This is best illustrated in the expansion of the defense to patent infringement based on earlier invention and use, commonly referred to as “prior user rights” or, more appropriately, the “prior user rights defense.”<sup>8</sup> A “prior user rights defense” generally refers to a limited defense to patent infringement afforded to a party that was commercially using, or engaged in substantial preparations for commercial use of, an invention that was later patented by another party.<sup>9</sup> This defense acknowledges the fact that inventors may, for a variety of reasons, prefer not to seek patent protection.<sup>10</sup> By allowing the earlier user/inventor to continue uninterrupted commercial use of the invention while also allowing the later inventor to obtain a patent enforceable against all others, the prior user right embodies a balance between the equitable economic interests of the earlier user against the larger goal of the patent system.<sup>11</sup> This larger goal of the patent system is the enrichment of the fund of human knowledge.<sup>12</sup> In so doing, the prior user right also may further the aim of the AIA in reducing litigation and related costs.<sup>13</sup>

The prior user rights defense to patent infringement is a common fixture in patent systems of many countries around the world,<sup>14</sup> and is not without precedent in the United States.<sup>15</sup> Prior to the

---

<sup>3</sup> Leahy-Smith America Invents Act, Pub. L. No. 112-29, 125 Stat. 284 (2011).

<sup>4</sup> H.R. REP. NO. 112-98, at 38 (2011).

<sup>5</sup> U.S. CONST. art. I, § 8, cl. 8.

<sup>6</sup> See H.R. REP. NO. 112-98, at 38-40.

<sup>7</sup> *Id.* at 40.

<sup>8</sup> The terms “prior user rights” and “prior use defense” are used interchangeably in this Report.

<sup>9</sup> See generally Keith Kupferschmid, *Prior User Rights: The Inventor’s Lottery Ticket*, 21 AIPLA Q.J. 213, 216 (1993) (defining detailed requirements for satisfying the defense), and Gary L. Griswold & F. Andrew Ubel, *Prior User Right—A Necessary Part of a First-to-File System*, 26 J. MARSHALL L. REV. 567, 572 (1993).

<sup>10</sup> See, e.g., H.R. REP. NO. 112-98, at 44 (noting, in particular, the tendency of high-technology businesses not to file for patent protection on every innovation).

<sup>11</sup> See Kupferschmid, *supra* note 9, at 217, 229.

<sup>12</sup> *Id.*

<sup>13</sup> H.R. REP. NO. 112-98, at 40.

<sup>14</sup> See discussion *infra* Part III.C.



enactment of the AIA, for instance, section 273 of Title 35 provided for a limited prior use defense applicable to business method patents. Section 273 of Title 35 is available in Appendix A. Section 273 was enacted as part of the 1999 American Inventors Protection Act (AIPA)<sup>16</sup> in response to the decision by the Court of Appeals for the Federal Circuit (CAFC) in *State Street Bank & Trust Co. v. Signature Financial Group, Inc.*,<sup>17</sup> which affirmed that business methods are eligible subject matter for patenting.<sup>18</sup> In doing so, however, the decision itself created uncertainty for United States businesses as to whether they might now be liable for patent infringement for continued use of internal business processes once thought to be unpatentable.<sup>19</sup> The *State Street* decision also followed several years of debate in Congress and academic and legal circles about introducing a broad prior user rights defense into United States patent law.<sup>20</sup> The language of section 273 reflected this confluence of circumstances by, on the one hand, providing an explicit provision for a prior user rights defense, and on the other hand, narrowly circumscribing its applicability to patents covering methods of doing or conducting business.

---

<sup>15</sup> See Patent Act of 1836, ch. 357, § 6, 5 Stat. 117 (1836); Patent Act of 1839, ch. 88, § 7, 5 Stat. 353 (1839); and Patent Act of 1870, ch. 230, § 24, 16 Stat. 198 (1870). Some commentators further argue that existing U.S. patent law continues to provide for a prior user rights defense even in the absence of an explicit provision. See, e.g., Griswold & Ubel, *supra* note 9, at 591 and 572 n.20 (quoting Judge Pauline Newman of the U.S. Court of Appeals for the Federal Circuit as saying “I have not seen anyone who was a prior user who has been stopped upon raising the [35 U.S.C. §] 102(g) defense and from that viewpoint, it seems that the prior user right is alive and well . . . [I]f we stay with the current first-to-invent system, we would be changing direction if we felt that there should not be prior user right.”); accord Karl F. Jorda, *Patent and Trade Secret Complimentariness: An Unsuspected Synergy*, 48 WASHBURN L.J. 1, 27 (2008) (pointing out that there has never been a reported case in the United States where a patentee has enjoined a prior user/trade secret owner).

<sup>16</sup> 35 U.S.C. § 273 (2006). See App. A (section 273 of the AIPA is reproduced for reference).

<sup>17</sup> 149 F.3d 1368 (Fed. Cir. 1998), *cert. denied*, 525 U.S. 1093 (1999).

<sup>18</sup> *Id.* at 1375.

<sup>19</sup> H.R. Rep. 106-464, at 122 (1999) (“The 1998 opinion by the U.S. Court of Appeals for the Federal Circuit in *State Street Bank and Trust Co. v. Signature Financial Group*, which held that methods of doing business are patentable, has added to the urgency” of providing prior user rights vis-à-vis such patents.).

<sup>20</sup> ADVISORY COMM.’N ON PATENT LAW REFORM, 102ND CONG., REPORT TO THE SEC. OF COM. (Comm. Print 1992); Patent Harmonization Act of 1992, H.R. 4978, 102d Cong. § 3 (1992); Patent Harmonization Act of 1992, S. 2605, 102d Cong. § 3 (1992); Prior User Rights Act of 1994, S. 2272, 103d Cong. (1994); Prior Domestic Commercial Use Act of 1995, H.R. 2235, 104th Cong. (1995); Inventor Rights Protection and Patent Reform Act of 1996, H.R. 3460, 104th Cong. §§ 301-303 (1996) (also known as the “Moorhead-Schroeder Patent Reform Act”); Omnibus Patent Act of 1996, S. 1961, 104th Cong. §§ 401-403 (1997); Omnibus Patent Act of 1997, S. 507, 105th Cong. §§ 401-403 (1997); 21st Century Patent Improvement Act, H.R. 400, 105th Cong. §§ 301-303 (1997). Compare Robert L. Rohrback, *Prior User Rights: Roses or Thorns?*, 2 U. BALT. INTELL. PROP. L.J. 1, 11-28 (1993) with Gary L. Griswold et al., *Letter to the Editor: Prior User Rights: Neither A Rose Nor A Thorn*, 2 U. BALT. INTELL. PROP. L.J. 233, 233-34 (1994) (specifically rebutting Rohrback by arguing that prior user rights would more fully reconcile trade secret and patent law); and Frank E. Robbins, *The Rights of the First Inventor-Trade Secret User as Against Those of the Second Inventor-Patentee (Part I)*, 61 J. PAT. & TRADEMARK OFF. SOC’Y 574, 587-89 (1979) with Karl F. Jorda, *The Rights of the First Inventor-Trade Secret User as Against Those of the Second Inventor-Patentee (Part II)*, 61 J. PAT. & TRADEMARK OFF. SOC’Y 593, 604-05 (1979).

The AIA makes a number of significant changes to the existing prior user rights defense. Most notably perhaps, the AIA expands the defense to all technologies, not just to business methods.<sup>21</sup> More specifically, the defense is available to persons who independently commercially employed the invention in the United States in connection with an internal commercial use, an arm's length sale, or an arm's length transfer of a useful end result of the commercial use.<sup>22</sup> To be entitled to the defense, however, the prior user must establish that the relevant activities occurred more than one year before the earlier of (1) the filing date of the patent application; or (2) the date of public disclosure by the patentee during the patentee's grace period.<sup>23</sup>

Importantly, the AIA provides for several limitations and exceptions to the new prior user rights defense. For example, the defense is personal, and thus may not be licensed, assigned, or transferred, other than in connection with an assignment or transfer of the entire business to which the defense relates.<sup>24</sup> In addition, the applicability of the defense is geographically limited to cover only those sites where the invention was used before the critical date.<sup>25</sup> The AIA further provides an explicit exception to the defense for patents owned by or assigned to universities or affiliated technology transfer organizations.<sup>26</sup> This latter provision relates to concerns expressed by the higher education community that prior user rights may impair the ability of universities to license patents on upstream research results.<sup>27</sup> Appendix B features the prior user rights provision of the AIA.

The AIA will serve to protect trade secret owners and other alleged infringers with a defense against patent infringement. This means that, in applicable cases, keeping your invention as a trade secret, such as a process that is used to make a product that is not disclosed to the world, is less risky for the business community. If someone invents a manufacturing process that improves or optimizes the efficiency, cost, or quality of producing a particular product, the inventor has the choice of either keeping the details of the process as a trade secret or file for patent protection. Without a prior use defense, the risk of going down the trade secret path is that a competitor who independently arrives at the same invention may obtain a patent and sue for infringement even though the prior user invented the enhancements and had been using it commercially for a long time.

---

<sup>21</sup> § 5(a), 125 Stat. at 297. See App. B (section 273 under the AIA is reproduced for reference).

<sup>22</sup> *Id.*

<sup>23</sup> *Id.*

<sup>24</sup> *Id.* at 298.

<sup>25</sup> *Id.*

<sup>26</sup> *Id.* at 298-99.

<sup>27</sup> See *America Invents Act: Hearing on H.R. 1249 Before the Subcomm. on Intellectual Property, Competition, and the Internet of the House Comm. on the Judiciary*, 112th Cong. 97-98 (2011) (Statement of John C. Vaughn, Exec. Vice President, Ass'n of Am. Univs.); see also *Prior User Rights (Relative to Patents): Hearing Before the Subcomm. on Intellectual Property and Judicial Administration of the House Comm. on the Judiciary*, 103d Cong. 99-101 (1995) (Statement of Teri F. Willey, Purdue Research Found.).

As with the creation of the prior user rights defense in the AIPA, the limited expansion of the defense in the AIA also sparked debate among the patent and business communities. Proponents argue that the defense is necessary in a competitive economy and strikes the balance between trade secret and patent protection. Proponents likewise argue a prior user rights defense is necessary in a first-inventor-to-file regime to provide inventors who put inventions to practice first with the ability to continue using their innovations, even though they may not be entitled to a patent. Critics argue, however, that prior user rights undermine the purpose of the patent system by creating a strong incentive to protect innovations as trade secrets rather than disclose them and fuel technological growth in the United States.

Given the opposing views on the prior user rights defense, Congress mandated in section 3 of the AIA that the USPTO produce a report on the operation on prior user rights in industrialized countries in order to explore the implications of a prior use defense in the United States. In particular, Congress required the USPTO to study the following topics, in consultation with the Office of the U.S. Trade Representative (USTR), Department of State (DOS), and Department of Justice (DOJ):

- (A) A comparison between patent laws of the United States and the laws of other industrialized countries, including members of the European Union and Japan, Canada, and Australia.
- (B) An analysis of the effect of prior user rights on innovation rates in the selected countries.
- (C) An analysis of the correlation, if any, between prior user rights and start-up enterprises and the ability to attract venture capital to start new companies.
- (D) An analysis of the effect of prior user rights, if any, on small businesses, universities, and individual inventors.
- (E) An analysis of legal and constitutional issues, if any, that arise from placing trade secret law in patent law.
- (F) An analysis of whether the change to a first-to-file patent system creates a particular need for prior user rights.<sup>28</sup>

This Report addresses each of the topics identified by Congress and analyzes “prior user rights” in the context of changes made by the AIA. This Report first provides background in Section II on the scope of the study that the agency undertook to fulfill its Congressional mandate. Next, the Report provides an international comparison of prior user rights in Section III, Part A, and then explores the

---

<sup>28</sup> § 3(m), 125 Stat. at 292.

impact of prior user rights on various innovation activities, including their relationship to start-ups, universities, and independent inventors in Section III, Part B. The Report examines the relationship between trade secret protection and patent law in Section III, Part C, as well as the interaction between the prior use defense and the provisions of the AIA that create a first-to-file patent system in the United States in Section III, Part D. When appropriate, the Report also provides findings and recommendations based on the analysis set forth in each section.

## **II. BACKGROUND**

To fully appreciate the role of prior user rights in the international arena and better understand the impact of a prior user rights defense on innovation and businesses, the USPTO gathered information and perspectives through a solicitation of public comments via a Federal Register Notice posted October 7, 2011.<sup>29</sup> The Federal Register Notice was posted on the USPTO Web site and the distributed to various intellectual property law organizations for dissemination to their members. Interested members of the public were invited to give oral testimony at a hearing scheduled for October 25, 2011, and/or submit written comments on issues related to the operation of prior user rights. The Notice specifically requested the public to share their experiences and opinions with respect to prior user rights in foreign jurisdictions.<sup>30</sup> Mirroring the language of the AIA, the Notice also asked the public to provide information with respect to the effect of prior user rights on innovation rates, start-up enterprises, small businesses, universities, and individual inventors.<sup>31</sup> Additionally, the Notice requested any comments on the legal analyses pertaining to the placing trade secret law in patent law and the interaction between the prior use defense and adoption of a first-inventor-to-file system in the United States.<sup>32</sup>

On October 25, 2011, the USPTO held a public hearing on these issues at the USPTO in Alexandria, Virginia. Five witnesses provided testimony, including Alan Kasper, Immediate Past President of the American Intellectual Property Law Association; Gary Griswold, Consultant and Chair Emeritus of the Coalition for 21<sup>st</sup> Century Patent Reform; Thomas Kowalski, Shareholder, Vedder Price, P.S.; Dan Lang, Vice President Intellectual Property and Deputy General Counsel, CISCO Systems, Inc.; and MaCharri Vorndran-Jones, Intellectual Property Law Section, American Bar Association. Subsequently, the USPTO received a total of 29 written comments from large and small companies, independent inventors, leading patent practitioners, the university community, academics, patent law

---

<sup>29</sup> Notice of Public Hearing and Request for Comments on the Study of Prior User Rights, 76 Fed. Reg. 62,388 (Oct. 7, 2011).

<sup>30</sup> *Id.* at 62,389.

<sup>31</sup> *Id.*

<sup>32</sup> *Id.*

scholars, and professional organizations.<sup>33</sup> Appendix C provides a listing of entities that provided input to the USPTO through oral testimony and/or written comments.

To complement the public submissions and in order to ensure an appropriate foundation of information on which to base the analyses contained in this Report, the USPTO also conducted an extensive literature review and consulted with patent officials from foreign patent offices. In addition, as required by Congress, the USPTO consulted with the USTR, the DOS, and the DOJ in compiling this Report.<sup>34</sup>

This Report, along with the findings and recommendations contained herein, are based on public comments, literature reviews, and independent legal research. All of the information gathered for this Report afforded the USPTO the opportunity to fairly evaluate the operation and impact of a prior use defense to patent infringement.

### **III. DISCUSSION**

#### **A. Comparison of Prior Use Provisions in Industrialized Countries**

The first inquiry of this congressionally mandated study is a comparison between the patent laws of the United States and those of other industrialized countries (“international comparison”) regarding the availability and scope of prior user rights. The mandate expressly identifies the following industrialized countries: the European Union, Japan, Canada, and Australia. In addition to the identified countries, this Report also takes into consideration other industrialized (and emerging) countries and key trading partners of the United States: the Republic of Korea, Brazil, Mexico, the People’s Republic of China (“China”), and the Russian Federation.

At the outset, the European Union does not, *per se*, encompass a common set of patent laws.<sup>35</sup> Instead, the patent system in Europe is governed by the European Patent Convention (EPC), which is a treaty outside the umbrella of treaties forming the European Union. The EPC does not establish a prior user rights regime. Thus, each member state of the European Union has its own unique prior user rights laws.<sup>36</sup> Accordingly, this Report focuses on a sample set of countries from the European Union that

---

<sup>33</sup> *Infra* App. C (list of parties providing testimony and/or comments); *see also* Comments on the Study of Prior User Rights, [http://www.uspto.gov/aia\\_implementation/prior-user-rights-comments.jsp](http://www.uspto.gov/aia_implementation/prior-user-rights-comments.jsp) (last visited Dec. 7, 2011).

<sup>34</sup> § 3(m), 125 Stat. at 292.

<sup>35</sup> Most members of the European Union are also contracting members of the European Patent Convention. *See generally* European Patent Office, Member states of the European Patent Organisation, <http://www.epo.org/about-us/organisation/member-states.html> (last visited December 16, 2011). However, the European Patent Convention (establishing the European Patent Office) is not a treaty under the European Union. Further, the European Patent Convention does not currently establish a unitary patent system.

<sup>36</sup> *Id.*

reflects different dimensions of populations, trade, and domestic economies. This sample set from the European Union includes: Denmark, France, Germany, and the United Kingdom.

Eight of twenty-nine public comments contained a discussion of particular experiences with prior user right regimes in foreign jurisdictions. Four of the eight were from entities based in other countries, including two from Australia,<sup>37</sup> one from New Zealand,<sup>38</sup> and one from Germany.<sup>39</sup> Additionally, one comment was from an international organization of patent practitioners.<sup>40</sup> Each of these submissions expressed the belief that prior user rights are important to achieving an equitable balance of interests, particularly from the perspective of a first-to-file system, though the degree of actual experience detailed in these submissions in terms of asserting or objecting to prior user rights varied substantially. Two of the comments, for instance, noted that those entities and/or their members had very little or no practical experience.<sup>41</sup> The other three comments, however, indicated that although there may be little litigation on prior user rights in certain jurisdictions, clients are counseled with some regularity on their applicability in particular situations.<sup>42</sup>

The remaining three of the eight comments were submitted by U.S.-based entities—two by companies representing different technology sectors<sup>43</sup> and the other from an organization representing a

---

<sup>37</sup> See generally Comments from Telstra Corp., to USPTO, Prior User Rights (Nov. 8, 2011) [hereinafter “Comments of Telstra Corp.”], [http://www.uspto.gov/aia\\_implementation/pur-2011nov08-telstra\\_corp.pdf](http://www.uspto.gov/aia_implementation/pur-2011nov08-telstra_corp.pdf); and Comments from David Tadgell, Convenor for the International Patents Committee, Institute of Patent and Trade Mark Attorneys, to the USPTO, Comments on the Study of Prior User Rights (Nov. 10, 2011) [hereinafter “Comments of Inst. of Patent and Trade Mark Attorneys of Australia”], [http://www.uspto.gov/aia\\_implementation/pur-2011nov10-ipta.pdf](http://www.uspto.gov/aia_implementation/pur-2011nov10-ipta.pdf).

<sup>38</sup> See generally Comments from Tim Jackson, President, New Zealand Inst. of Patent Attys., Inc., to David Kappos et al., Undersecretary Dept. of Comm. for Intell’l Prop., and Director of the USPTO (Nov. 9, 2011) [hereinafter “Comments of New Zealand Inst. of Patent Attys., Inc.”], [http://www.uspto.gov/aia\\_implementation/pur-2011nov09-nzipa\\_inc.pdf](http://www.uspto.gov/aia_implementation/pur-2011nov09-nzipa_inc.pdf).

<sup>39</sup> Comments from Stephan Freischam, European Patent Attorney, Patentanwaelte Freischem, to Elizabeth Shaw, IP Research Specialist Supervisor, USPTO, Office of Policy and External Affairs, Prior User Rights (Nov. 8, 2011) [hereinafter “Comments of Freischem”], [http://www.uspto.gov/aia\\_implementation/pur-2011-stephan\\_freischem.pdf](http://www.uspto.gov/aia_implementation/pur-2011-stephan_freischem.pdf).

<sup>40</sup> Comments from the International Federation of Intell. Prop. Attorneys, to the U.S. Patent and Trademark Office (Nov. 16, 2011) [hereinafter “Comments from FICPI”], [http://www.uspto.gov/aia\\_implementation/pur-2011nov16-ficpi.pdf](http://www.uspto.gov/aia_implementation/pur-2011nov16-ficpi.pdf).

<sup>41</sup> Comments of Telstra Corp., *supra* note 37, at 1, and Comments of New Zealand Inst. of Patent Attys., Inc., *supra* note 38, at 1.

<sup>42</sup> Comments of Inst. of Patent and Trade Mark Attorneys of Australia, *supra* note 37, at 2; Comments of Freischem, *supra* note 39, at 2; and Comments of FICPI, *supra* note 40, at 2.

<sup>43</sup> Comments from Jason Albert, Associate General Counsel for Intell. Prop. Policy & Strategy, Microsoft Corp., to USPTO, Comments of Microsoft Corp. (Nov. 8, 2011) [hereinafter “Comments of Microsoft Corp.”], [http://www.uspto.gov/aia\\_implementation/pur-2011nov08-microsoft\\_corporation.pdf](http://www.uspto.gov/aia_implementation/pur-2011nov08-microsoft_corporation.pdf); and Comments from Leah Taylor, Vice-President for Intell’l Prop., Hospira Inc., to Elizabeth Shaw, IP Research Specialist Supervisor, USPTO, Office of Policy and External Affairs, Prior User Rights (Nov. 8, 2011) [hereinafter “Comments of Hospira, Inc.”], [http://www.uspto.gov/aia\\_implementation/pur-2011nov08-hospira\\_inc.pdf](http://www.uspto.gov/aia_implementation/pur-2011nov08-hospira_inc.pdf) (“a global specialty pharmaceutical and medication delivery company”).

range of U.S. patent owners and stakeholders.<sup>44</sup> Both of the companies were supportive of prior user rights as a general matter, though, as with several of the above-mentioned comments from international stakeholders, neither indicated a significant degree of practical experience with exercising them.<sup>45</sup> The comments of the organizations were generally critical of prior user rights and, while acknowledging that none of its members had ever utilized prior user rights, noted that many of the arguments advanced by proponents are not supported by empirical evidence or other data.<sup>46</sup>

Eight other submissions touched on international aspects of prior user rights, but did not directly identify any particular experiences in applying them. These submissions were from a range of stakeholders—individuals, companies, and coalitions—and generally focused on the need to adopt prior user rights in the United States in order to level the international playing field for U.S. innovators and promote job growth in America.<sup>47</sup> A few of the comments, in particular, noted that the absence of prior user rights in the United States could give an advantage to foreign competitors that may have cheaper labor costs or are subsidized by foreign governments.<sup>48</sup>

On balance, the public comments suggest that prior user rights are not problematic in other jurisdictions, and in fact, are a well-accepted practice. Only a few of the submissions detailed any actual experiences with prior user rights in foreign countries, and each of these was generally positive; none of the comments identified any first-hand, negative experiences. Moreover, several of the comments specifically noted that there has been little or no litigation of prior user rights in other countries, which suggests they are not creating any systemic issues.

---

<sup>44</sup> Comments from Brian Pomper, Executive Director, Innovation Alliance, to Elizabeth Shaw, IP Research Specialist Supervisor, USPTO, Office of Policy and External Affairs, Comments on the Study of Prior User Rights (Nov. 8, 2011) [hereinafter “Comments of Innovation Alliance”], [http://www.uspto.gov/aia\\_implementation/pur-2011nov08-hospira\\_inc.pdf](http://www.uspto.gov/aia_implementation/pur-2011nov08-hospira_inc.pdf).

<sup>45</sup> Comments of Microsoft Corp., *supra* note 43, at 2. *See generally* Comments of Hospira, Inc., *supra* note 43.

<sup>46</sup> Comments of Innovation Alliance, *supra* note 43, at 1.

<sup>47</sup> Comments from Robert Barr et al., Executive Director, Berkeley Center for Law and Tech., Univ. of Cal., Boalt Hall Law School, to David Kappos et al., Undersecretary Dept. of Comm. for Intell’l Prop. and Director of the USPTO, Prior User Rights for Venture Capital Backed Greentech Indus. 2-3 (Nov. 6, 2011) [hereinafter “Comments of Greentech”], [http://www.uspto.gov/aia\\_implementation/pur-2011nov06-berkeley-center.pdf](http://www.uspto.gov/aia_implementation/pur-2011nov06-berkeley-center.pdf); Comments from Thomas Kelley, Consulting Patent Counsel, Monsanto Co., to the USPTO, Prior User Rights 2 (Nov. 8, 2011) [hereinafter “Comments of Thomas Kelly”], [http://www.uspto.gov/aia\\_implementation/pur-2011nov08-thomas\\_kelley.pdf](http://www.uspto.gov/aia_implementation/pur-2011nov08-thomas_kelley.pdf); Thomas Kowalski, Shareholder, Vedder Price P.C., Comments at the Public Hearing on the Study of Prior User Rights 19 (Oct. 25, 2011) [hereinafter “Testimony of Thomas Kowalski”], [http://www.uspto.gov/aia\\_implementation/20111025-prior-user-rights-transcript.pdf](http://www.uspto.gov/aia_implementation/20111025-prior-user-rights-transcript.pdf); Comments from James F. Kurkowski, Chief Intell. Prop. Counsel, Space Exploration Techs. Corp., to the USPTO, Comments of Space Exploration Techs. Corp. 4-5 (Nov. 8, 2011) [hereinafter “Comments of Space Exploration Techs. Corp.”] [http://www.uspto.gov/aia\\_implementation/pur-2011nov08-space\\_exploration\\_tech\\_corp.pdf](http://www.uspto.gov/aia_implementation/pur-2011nov08-space_exploration_tech_corp.pdf); Comments from Dan Lang, Vice President Intellectual Property for Cisco Systems, Inc., to the USPTO, Written Comment on behalf of the Coalition for Patent Fairness 4-7 (Nov. 8, 2011) [hereinafter “Comments from Coalition for Patent Fairness”] [http://www.uspto.gov/aia\\_implementation/pur-2011oct25-cisco.pdf](http://www.uspto.gov/aia_implementation/pur-2011oct25-cisco.pdf).

<sup>48</sup> Comments of Greentech, *supra* note 47, at 1-2; *and* Comments of Space Exploration Techs. Corp., *supra* note 47, at 2.

Separate from the public’s anecdotal evidence on the use of prior user rights in foreign jurisdictions, the USPTO conducted an analysis of the prior user rights laws of the above-mentioned countries, focusing on the necessary requirements to assert the prior user rights defense and the scope of said prior user rights defense. A summary of the USPTO’s findings about prior user rights law in foreign countries is provided in Appendix D.

## **Analysis and Findings**

### **1. Requirements to Assert the Prior User Rights Defense**

For the most part, the requirements that a party must satisfy to qualify for a prior user rights defense include: (a) qualifying prior use activities; (b) qualifying prior user; (c) qualifying time period; and (d) qualifying locations. The following is a summary and comparison of the differing national requirements.

#### **a. Qualifying Prior Use Activities**

A primary inquiry for qualifying for the benefit of prior user rights laws is determining the type of activity that can legally be deemed as a prior use activity. With respect to the countries in this study, prior use ranges from prior commercial use, to mere possession of an invention.<sup>49</sup> In many instances, a hybrid form of the two is incorporated (e.g., use and substantial preparations for the same).<sup>50</sup> In addition, even within a single country, prior use may be defined differently based on the type of invention at issue. That is to say, an activity constituting prior use as to a product invention can sometimes fail to qualify as a prior use activity as to a process invention.<sup>51</sup> Of course, this requirement varies from country-to-country. Still, despite the differences, the overarching narrative regarding prior use is that the legally qualifying activity is dependent on the actions of a prior user and/or the type of invention at issue.

With regard to the level of activity by a party asserting prior user rights, prior use activities can be categorized as either: (i) pure use; (ii) pure possession; or (iii) use-possession hybrids. The jurisdictions with a pure “use” definition are Brazil and Canada. The only jurisdiction with a pure “possession”

---

<sup>49</sup> See generally Comments of FICPI, *supra* note 40, at 3 (noting that in some jurisdictions “the prior use covers the mere intellectual possession of the same invention, independently from the intention to effectively exploit such invention. In other jurisdictions . . . the ‘use’ is restricted to an effective industrial use.”).

<sup>50</sup> See generally *id.* (“Other jurisdictions have an in-between approach, where the use is extended to serious and effective preparation to such industrial use.”).

<sup>51</sup> See, e.g., Patents Act, 1990 (Austl.), § 119(5) [hereinafter “Australian Patent Law”] (defining exploitation differently based on the type of invention).



definition is France. The rest of the studied countries adopt a use-possession hybrid form of prior use. Even between these use-possession hybrid regimes, a main point of divergence is the threshold for determining “possession.”

Brazil’s patent laws limit prior use activity to pure use.<sup>52</sup> More specifically, prior use activity in Brazil is defined as “exploitation” of the patented subject matter.<sup>53</sup> Accordingly, non-use of the invention, or even marginal use (e.g., preparations for the eventual use thereof), may act as a *de facto* waiver of a party’s right to assert a prior user rights defense during litigation. Similarly, prior use in Canada is defined as “the purchase, construction, or acquisition” of a later patented invention.<sup>54</sup>

In contrast, prior use in France is limited to “possession of the invention.”<sup>55</sup> The particulars as to what constitutes “possession of the invention” are not fully settled.<sup>56</sup> Generally speaking, however, preparatory studies are insufficient to establish prior user rights, but preparations of an industrial/productive nature would suffice to show “possession of an invention.”<sup>57</sup>

The rest of the studied countries have a use-possession hybrid definition of prior use. For example, in Denmark, activities that constitute prior use include: (i) exploiting the invention commercially; and (ii) making substantial preparations for commercial exploitation of the same.<sup>58</sup>

---

<sup>52</sup> See Kenneth Félix Haczynski da Nóbrega, Head of the Intell’l Prop. Division, Ministry of External Relations, Submission in Response to WIPO Questionnaire on Exceptions and Limitations to Patent Rights, 9-11, <http://www.wipo.int/export/sites/www/scp/en/exceptions/submissions/brazil.pdf> (last visited Dec. 17, 2011); and Comments from FICPI, *supra* note 49, at 3.

<sup>53</sup> Law No. 9.279 of 14 May 1996, Sec. II, art. 45 (Brazil) [hereinafter “Brazilian Patent Law”] (“A person who in good faith, prior to the filing or priority date of a patent application, was exploiting the object thereof in this country, shall be assured the right to continue the exploitation, without onus, in the same manner and under the same conditions as before . . .”).

<sup>54</sup> Canada Patent Act, R.S.C., 1985, ch. P-4, § 56(1) (2006) [hereinafter “Canadian Patent Act”].

<sup>55</sup> Act No. 92-597 of July 1, 1992 of the Intell. Prop. C., Official Journal (France), July 3, 1992, art. L613-7, *amended by* Act No. 96-1106 of December 18, 1996 of the Intell. Prop. C., Art. 4, Official Journal, Dec. 19, 1996 (updates last consolidated by Act No. 2006-236 of Mar. 1, 2006 of the Intell. Prop. C., Official Journal, Mar. 2, 2006.) [hereinafter “French Intell’l Prop. Law”] (“Any person who, within the territory in which this Book applies, at the filing date or priority date of a patent was, in good faith, in possession of the invention which is the subject matter of the patent shall enjoy a personal right to work that invention despite the existence of the patent.”); *see also* Testimony of Thomas Kowalski, *supra* note 47, at 19 (noting that in France “mere possession of an invention prior to the patent application can be sufficient to defeat an infringement claim”).

<sup>56</sup> Compare Francois Pochart, *Prior User’s Rights in France*, UNION-IP (European Practitioners in Intell. Prop.) Congress Port. 7-12 (2008), with Daphne DeBeco, Official Representative, International and European Affairs Service, National Institute of Indus. Prop. (Fr.), Responses to WIPO Questionnaire on Exceptions and Limitations to Patent Rights, [http://www.wipo.int/export/sites/www/scp/en/exceptions/translation/france\\_en.pdf](http://www.wipo.int/export/sites/www/scp/en/exceptions/translation/france_en.pdf) (last visited Dec. 16, 2011) (indicating that “the invention must be *known completely*.”).

<sup>57</sup> *Id.*

<sup>58</sup> Law No. 91 of 28 January 2009, Consolidate Patents Act, §4(1) (Den.) [hereinafter “Danish Patents Act”] (“Any person who, at the time when the patent application was filed, was exploiting the invention commercially in this country may, notwithstanding the grant of a patent, continue such exploitation retaining its general character [...] Such a right of exploitation shall also, under similar conditions, be enjoyed by any person who had made substantial preparations for commercial exploitation of the invention in this country.”); *see generally* Flemming K. Mejl, Chief Technical Adviser, Danish Patent and Trademark Office, Response to WIPO Questionnaire on Exceptions and

Likewise, in Australia, prior use is defined as either: (i) exploiting the product, method, or process; or (ii) taking definite steps to do the same. Similar definitions are set out in the laws of Japan,<sup>59</sup> the Republic of Korea,<sup>60</sup> Mexico,<sup>61</sup> China,<sup>62</sup> and the Russian Federation.<sup>63</sup>

Some of these use-possession hybrid countries afford varying possession standards. For example, the United Kingdom has a very stringent possession standard. The United Kingdom defines prior use as “acts that would constitute infringement” of a patent or “effective and serious preparation” to do the same.<sup>64</sup> With regard to making “effective and serious preparation,” the United Kingdom’s case law suggests that mere possession of an invention, without proactive steps to manufacture or commercialize the same, is not enough activity to be deemed prior use.<sup>65</sup> In contrast, Germany has an easily satisfied possession standard. In Germany, activities that constitute prior use include “use of the invention” and making “necessary arrangements to do the same.”<sup>66</sup> With regard to the latter, a party asserting the defense must show actual possession of the invention.<sup>67</sup> Possession of the invention simply means that the asserting party must be knowledgeable of the invention and be able to intentionally exploit the invention.<sup>68</sup> This low threshold is circumscribed by the fact that prior use in Germany is limited to

---

Limitations to Patent Rights 8-9, <http://www.wipo.int/export/sites/www/scp/en/exceptions/submissions/denmark.pdf>.

<sup>59</sup> Patent Act, Act No. 121 of 1959, art. 79 (amended by Act No. 75 of June 29, 2005.) [hereinafter “Japanese Patent Act”] (where use is defined as “working the invention”, and possession is defined as making “preparing” for the same).

<sup>60</sup> Patent Act, Dec. 31, 1961, art. 103 (last amended by Act No. 9381, Jan. 30, 2009.) [hereinafter “Korean Patent Act”] (where use is defined as “working the invention”, and possession is defined as making “preparations” for the same).

<sup>61</sup> Indus. Prop. Law, Mexican Federation Official Diary, Art. 22.III, January 25, 2006 [hereinafter “Mexican IP Law”] (where use is defined simply as use, and possession is defined as making “necessary preparations” for the same).

<sup>62</sup> Patent Law of the People’s Republic of China, art. 69(2) (promulgated by the Standing Comm. Nat’l People’s Cong., Dec. 27, 2008, effective Oct. 1, 2009.) [hereinafter “Chinese Patent Law”] (where use is defined as “use/manufacture,” and possession is defined as “making necessary preparations” for the same).

<sup>63</sup> Patent Law, 2003 (Russ.), § IV, art. 12 [hereinafter “Russian Patent Law”] (where use is defined simply as use, and possession is defined as making “necessary preparations” for the same).

<sup>64</sup> Patents Act, 1977, c. 37, § 64 (Eng.) [hereinafter “U.K. Patent Act”] (“(1) Where a patent is granted for an invention, a person who in the United Kingdom before the priority date of the invention does in good faith an act which would constitute an infringement of the patent if it were in force, or makes in good faith effective and serious preparations to do such an act, shall have the rights conferred by subsection (2). . . .”).

<sup>65</sup> Andrew Webb, *Prior Use Under Section 64 of the UK Patents Act 1977*, UNION-IP, white paper ¶¶ 4.6-4.10 (European Practitioners in Intell. Prop.) Congress Port. (2008) (citing *Helitune Ltd. v. Stewart Hughes Ltd.*, [1991] F.S.R. 171, and *Lubrizol Corp., et al. v. Esso Petroleum Co., et al.*, [1998] R.P.C. 727 (CA)).

<sup>66</sup> Patent Act (F.R.G.), Dec. 16, 1980, BGBl. I at 1981, last amended by Gazette (F.R.G.), Jul. 31, 2009, BGBl. I at 2521, pt. 1, § 12 [hereinafter “German Patent Act”].

<sup>67</sup> Sabine Rojahn, *Right of Private Prior Use: Sec. 12 Patent Act*, UNION-IP (European Practitioners in Intell. Prop.) Congress Port., slides 5-8 (2008).

<sup>68</sup> *Id.*

business or enterprise activities of a defendant.<sup>69</sup> Thus, prior use in Germany must be independent of any third parties and solely in the interest of the party asserting a prior user rights defense.<sup>70</sup> The use of a third party to realize the invention is not considered a prior use activity.<sup>71</sup> However, production for others is permissible.<sup>72</sup>

In view of the above, the prior user rights defense of the AIA appears to adopt a use definition similar to most of the studied countries. Under the AIA, prior use activity is defined as commercial use, “either in connection with an internal commercial use or an actual arm’s length sale or other arm’s length commercial transfer of a useful end result of such commercial use.”<sup>73</sup> The statute also affirmatively sets forth several scenarios in which subject matter is explicitly considered as being “commercially used” and thus eligible for the prior user rights defense.<sup>74</sup> For example, one provision states that subject matter for which commercial marketing or use is subject to a premarketing regulatory review period during which safety or efficacy is established shall be deemed to be commercially used for purposes of the prior user right defense during the regulatory review period.<sup>75</sup> Additionally, a second provision provides that use of the subject matter by a “nonprofit research laboratory or other nonprofit entity, such as a university or hospital, for which the public is the intended beneficiary” will be considered a “commercial use” for purposes of the prior user right defense.<sup>76</sup>

It is noteworthy to briefly discuss in this study how in some jurisdictions, prior use may have different definitions based on statutory subject matter. These prior use definitions can be divided into three types: (i) activities related to product-inventions; (ii) activities related to product-by-process inventions; and (iii) activities related to process inventions. Of these, activities (i) and (ii) are usually coextensive.

For example, in Australia, the prior use standard is exploitation (and taking definitive step towards exploitation) of “the product, method or process in the patent area.”<sup>77</sup> Exploitation, per the Australian standard, is defined differently based on the subject matter of the invention.<sup>78</sup>

---

<sup>69</sup> German Patent Act, at § 12(1); *see also* German Patent and Trademark Office, Response to WIPO Questionnaire on Exceptions and Limitations to Patent Rights 8, <http://www.wipo.int/export/sites/www/scp/en/exceptions/submissions/germany.pdf> (last visited Dec. 21, 2011).

<sup>70</sup> Rojahn, *supra* note 67, at slide 10.

<sup>71</sup> *Id.*

<sup>72</sup> *Id.* at slide 17.

<sup>73</sup> § 5, 125 Stat. at 297 (to be codified at 35 U.S.C. § 273(a)).

<sup>74</sup> *Id.* (to be codified at 35 U.S.C. § 273(c)).

<sup>75</sup> *Id.* (to be codified at 35 U.S.C. § 273(c)(1)).

<sup>76</sup> *Id.* (to be codified at 35 U.S.C. § 273(c)(2)).

<sup>77</sup> Australian Patent Law, at § 119(5).

<sup>78</sup> *Id.*; *See also* Adam Wright, Assistant Director, International Policy and Cooperation, IP Australia, Response to WIPO Questionnaire on Exceptions and Limitations to Patent Rights 12-15,

Product-inventions and product-by-process inventions encompass a significant amount of activities under the rubric of *exploitation*.<sup>79</sup> One of the many activities under this nomenclature is offering to sell. In contrast, exploitation with respect to a pure process invention is limited to actual use only.<sup>80</sup> Thus, offering to sell a process invention does not trigger prior user rights. Similar to Australia, the countries of Japan<sup>81</sup> and the Republic of Korea<sup>82</sup> have different meanings based on the subject matter of an invention.<sup>83</sup> It should be noted, however, that most of the other studied countries do not have this piecemeal approach, and apply the same “use” standard across the board.

Unlike Australia, prior use activity under the AIA is not defined differently based on statutory subject matter. That is to say, the same “commercial use” standard is applied to all statutory subject matter, specifically defined in the AIA as, “subject matter consisting of a process, or consisting of a machine, manufacture, or composition of matter.”<sup>84</sup>

## **b. Qualifying Prior User**

A second inquiry for qualifying for the benefit of prior user right laws is “who” is a prior user. This inquiry focuses on ascertaining whether a prior user has to be the actual inventor, or alternatively, if a prior user may encompass someone who acquired the invention from another. In most countries, anyone who acquired an infringing invention, prior to the date of filing of the patent application, may assert a prior user rights defense. Most of these countries also have a requirement of good faith, discussed more fully below.

A requirement of invention in a prior user rights regime means that only an earlier inventor may assert prior user rights. Under such a system, prior user rights originally vest in a prior inventor. From that point, the right (or defense) can be transferred according to the legal standard of a particular country (discussed further below). The only country with a pure invention requirement appears to be Russia.<sup>85</sup>

---

<http://www.wipo.int/export/sites/www/scp/en/exceptions/submissions/australia.pdf> (last visited Dec. 16, 2011), and Comments of Inst. of Patent and Trade Mark Attorneys of Australia, *supra* note 37.

<sup>79</sup> Australian Patent Law, at § 119(5).

<sup>80</sup> *Id.*

<sup>81</sup> Japanese Patent Act, at art. 2(3).

<sup>82</sup> Korean Patent Act, at art. 103.

<sup>83</sup> Of note is that prior use in Japan also encompasses “providing [computer software] through an electric telecommunication line.” Japanese Patent Act art. 2(3); *see also* Yuichiro Nakaya & Gen Aida, Deputy Director & Assistant Director, Japan Patent Office, Response to WIPO Questionnaire on Exceptions and Limitations to Patent Rights 8-12, [http://www.wipo.int/export/sites/www/scp/en/exceptions/submissions/japan\\_rev.pdf](http://www.wipo.int/export/sites/www/scp/en/exceptions/submissions/japan_rev.pdf) (last visited Jan. 13, 2012).

<sup>84</sup> § 5, 125 Stat. at 297 (to be codified at 35 U.S.C. § 273(a)).

<sup>85</sup> Russian Patent Law, at art. 12.

According to Russia’s patent law, any person who, prior to the date of filing, had “conceived and was using in good faith” an invention may seek benefit of prior user rights.<sup>86</sup>

In contrast, those jurisdictions that permit acquisition in their prior user rights regime allow anyone who has acquired the invention, through a purchase or conveyance, may assert prior user rights. It is noteworthy to indicate that, with the exception of Russia, every country studied permits prior user rights-based acquisition.<sup>87</sup> For example, in the United Kingdom, a party claiming benefit of prior user rights need only *perform any act* that would otherwise constitute infringement.<sup>88</sup> Thus, the prior user right is not contingent on prior invention of the subject matter.<sup>89</sup>

In view of the above, it appears that the AIA also has a standard consistent with the large majority of the studied countries in permitting acquisition of prior user rights. More specifically, the AIA states that the prior user rights defense “may be asserted only by the person who performed or directed the performance of the commercial use [...], or by an entity that controls, is controlled by, or is in common control with such a person.”<sup>90</sup> In other words, the defense can be asserted by anyone that would be directly, or indirectly, liable of infringement to a patent holder of the same invention.<sup>91</sup> The AIA does not require that a prior user be an actual inventor.

Further, the presence of a good faith requirement helps determine whether a party may be disqualified from asserting prior user rights. All of the countries subject to this study have a good faith requirement in one form or another (i.e., statutorily, administratively, or jurisprudentially), with the exception of Mexico. Mexican law is silent on this issue of good faith, and the study did not find any administrative or judicial mention of good faith with respect to prior user rights. Good faith varies in definition, such that some countries’ laws articulate specific acts that defeat the prior user right, while others have a general statement of “good faith” requirement. The latter, thus, may encompass inequitable activities that extend beyond copying.

With respect to the narrowly tailored good faith requirements, Germany, Denmark, France, Australia, and Japan provide insight as to the variance between these articulated good faith definitions. For example, German patent law includes a provision where if a party enters into a non-disclosure agreement with an eventual patent holder, the party is expressly required to wait six months before

---

<sup>86</sup> *Id.*

<sup>87</sup> *See generally* U.K. Patent Act, at § 64; German Patent Act § 12; Danish Patents Act, at § 4(1); French Intell’l Prop. Law, at art. L613-7; Canadian Patent Act, at § 56(1); Brazilian Patent Law, at art. 45; Mexican IP Law, at Art. 22.III; Australian Patent Law, at § 119; Japanese Patent Act, at art. 79; Korean Patent Act, at art. 103; *and* Chinese Patent Law, at art. 69(2).

<sup>88</sup> U.K. Patent Act, at § 64.

<sup>89</sup> Webb, *supra* note 65, at ¶ 8.1.

<sup>90</sup> § 5, 125 Stat. at 298 (to be codified at 35 U.S.C. § 273(e)(1)(A)).

<sup>91</sup> *Id.* (to be codified at 35 U.S.C. § 273(a)).

asserting a prior use defense against the same patent holder, assuming the patent holder did not previously file a patent application.<sup>92</sup> Thus, how a party obtained knowledge of an invention (either from a patentee, third party, or independently) is of little value in Germany.<sup>93</sup> In fact, merely learning of a patent applicant's invention is not, *ipso facto*, sufficient grounds to support an allegation of bad faith.<sup>94</sup> A party would have to also show breach of contract and/or misappropriation, among other things.<sup>95</sup> Another example of a narrowly tailored good faith requirement is Denmark, where prior user rights will only exist "provided that the exploitation did not constitute *an evident abuse in relation to* the [patent] applicant or his legal predecessor."<sup>96</sup> In Australia, a person may not claim benefit of prior user rights if he/she "derive[d] their invention from the patent holder, or patentee's predecessor," unless that information was voluntarily made available by the patent holder.<sup>97</sup> Finally, in Japan good faith is defined as "*a lack of knowledge of the content of a patent application.*"<sup>98</sup> Thus, this sample set of good faith standards illustrate how varied good faith standards can be from one jurisdiction to another.<sup>99</sup>

In contrast, some countries have a general good faith requirement. These general requirements do not articulate a specific activity that would bar a party from asserting prior user rights. As a consequence, this general good faith requirement is much broader. For example, France's prior user rights law states that any person who satisfies the various elements for claiming benefit of prior user rights, and acted "in good faith," may assert such a right.<sup>100</sup> Specific activities that would constitute (or destroy) good faith are not articulated. Nonetheless, practitioners understand that this broad standard encompasses various inequitable activities, such as acquiring an invention in breach of a contractual obligation.<sup>101</sup> Other countries that have a generalized good faith requirement are the United Kingdom,<sup>102</sup> Brazil,<sup>103</sup> and the Russian Federation.<sup>104</sup>

---

<sup>92</sup> German Patent Act, at § 12(1) ("If the applicant or his predecessor in title, before applying for a patent, disclosed the invention to other persons and reserved his rights in the event of a patent being granted, said person learning of the invention as a result of such disclosure cannot invoke measures under the provisions of the first sentence, which he has taken within six months after the disclosure.").

<sup>93</sup> Rojahn, *supra* note 67, at slide 8.

<sup>94</sup> Rojahn, *supra* note 67, at slide 8.

<sup>95</sup> *Id.*

<sup>96</sup> Danish Patents Act, at § 4(1).

<sup>97</sup> Australian Patent Law, at § 119(3).

<sup>98</sup> Japanese Patent Act, at art. 79.

<sup>99</sup> Another narrowly defined good faith standard is that of Republic of Korea. Korean Patent Act, at art. 103 (good faith standard is defined as "a person without knowledge of the content of an invention").

<sup>100</sup> French Intell'l Prop. Law, at art. L613-7.

<sup>101</sup> Pochart, *supra* note 56, at 5.

<sup>102</sup> U.K. Patent Act, at §64(1).

<sup>103</sup> Brazilian Patent Law, at art. 45.

<sup>104</sup> Russian Patent Law, at art. 12.

Some countries do not specifically articulate a good faith requirement in their laws, but incorporate similar standards through some other vehicle. Canada, for example, does not articulate any good faith requirement. However, Canadian courts have interpreted its patent law to include some form of "good faith" requirement.<sup>105</sup> While Canadian courts may not prevent acquisition of prior user rights based merely on what might be considered "dishonorable" behavior, they have disallowed prior user rights when the prior use activity approaches fraud. As such, the Canadian prior user rights regime requires some level of "good faith," although it is based on case law rather than on a statutory requirement.

Likewise, China's prior user rights laws do not articulate a specific good faith requirement.<sup>106</sup> Nonetheless, there is at least a minimal good faith requirement in China imposed by the courts.<sup>107</sup> In particular, an alleged infringer cannot claim the prior user right defense on the basis of illegally obtained technology or designs.<sup>108</sup> Mexico is also another country that does not specifically articulate a good faith requirement in the law, and it is unclear whether Mexico imposes a good faith requirement.<sup>109</sup>

The AIA has both a general good faith requirement, and also an articulation of specific conduct that would defeat the prior user rights defense. The general articulation of the good faith requirement is that a prior user must be, "acting in good faith, [to] commercially [use] the subject matter in the United States."<sup>110</sup> In addition to this general requirement, the AIA goes on to further articulate a specific activity. More specifically, that "[a] person may not assert a defense under this section if the subject matter on which the defense is based was derived from the patentee or persons in privity with the patentee."<sup>111</sup> Thus, generally speaking, the AIA is consistent with the countries examined in this Report on two fronts, by including a generalized and an articulated good faith standard.

### c. Qualifying Time Period

A third inquiry in qualifying for the benefit of prior user right laws is "when" must prior use activity take place. By definition, the prior use activity must take place *before* a specific date related to the grant of a patent. Thus, this inquiry focuses on said specific date. In this regard, the temporal

---

<sup>105</sup> Gregor Binkley, *Prior User Rights in the Canadian Patent Act*, 18 C.I.P.R. 207, 226 (2001).

<sup>106</sup> Chinese Patent Law, at art. 69(2).

<sup>107</sup> Liu Xiaojun, *A Synopsis on Defenses to Patent Infringement*, China Intell. Prop., Mar. 6, 2011, available at [http://ipr.chinadaily.com.cn/2011-03/06/content\\_12124863.htm](http://ipr.chinadaily.com.cn/2011-03/06/content_12124863.htm). See also Judicial Interpretation of the Supreme People's Court on Several Issues concerning the Application of Law in the Trial of Patent Infringement Dispute Cases, art. 15 (promulgated by the Supreme Judicial Committee, Dece. 21, 2009, effective Jan. 1, 2010).

<sup>108</sup> *Id.*

<sup>109</sup> Mexican IP Law, at art. 22.III.

<sup>110</sup> § 5, 125 Stat. at 297 (to be codified at 35 U.S.C. § 273(a)).

<sup>111</sup> *Id.* (to be codified at 35 U.S.C. § 273(e)(2)).

requirement of all the studied countries is generally consistent, with some exceptions as noted below. For all the studied countries, the prior use activity must take place before the earliest effective filing date of the patent application.<sup>112</sup> For example, in the United Kingdom, the activity constituting prior use must take place before the priority date of an invention.<sup>113</sup> According to the *U.K. Patent Act*, the priority date of an invention is defined as the date that an application was filed, or the date that the earliest parent application was filed.<sup>114</sup>

Germany's prior user rights laws, however, have special provisions that directly affect this otherwise consistent temporal requirement. In Germany, prior use activity must take place at, or before, the date of filing.<sup>115</sup> Like the rest of the studied countries, a patentee can claim priority to a parent application.<sup>116</sup> However, this rule does not apply to nationals of a foreign country that does not have reciprocity laws.<sup>117</sup> Therefore, foreigners from said countries are limited to the actual filing date of an application. That is to say, a prior user need only beat a national filing date, as opposed to priority date related to a foreign application from a jurisdiction without reciprocal laws.

With respect to the AIA, the U.S. further builds upon the temporal requirement of the studied countries. In order to assert the prior user rights defense under the AIA, commercial use must have occurred at least one year before the earlier of either: "(A) the effective filing date of the claimed invention; or (B) the date on which the claimed invention was disclosed to the public in a manner that qualified for the exemption from the prior art under section 102(b)."<sup>118</sup> This makes the U.S. temporal approach significantly more restrictive than that for any other prior user rights system.

#### **d. Qualifying Locations**

The final inquiry in qualifying for the benefit of prior user rights laws is "where" prior use activity must take place. More specifically, prior user rights laws articulate a specific geographical or political area where prior use activities will be legally recognized as triggering the benefit of the same set of laws. Like the previous inquiry, most studied countries have consistent provisions regarding the

---

<sup>112</sup> See generally U.K. Patent Act, at § 64; German Patent Act § 12; Danish Patents Act, at § 4(1); French Intell'l Prop. Law, at art. L613-7; Canadian Patent Act, at § 56(1); Brazilian Patent Law, at art. 45; Mexican IP Law, at Art. 22.III; Australian Patent Law, at § 119; Japanese Patent Act, at art. 79; Korean Patent Act, at art. 103; and Chinese Patent Law, at art. 69(2).

<sup>113</sup> U.K. Patent Act, at § 64.

<sup>114</sup> U.K. Patent Act, at § 5.

<sup>115</sup> German Patent Act, at § 12(2).

<sup>116</sup> *Id.*

<sup>117</sup> *Id.*

<sup>118</sup> § 5, 125 Stat. at 297 (to be codified at 35 U.S.C. § 273(a)).



locality of prior use.<sup>119</sup> More specifically, the prior use must take place within the borders of each respective country. Thus, activities taking place within a foreign country are not taken into account in determining whether the prior use defense is available.

For example, in Japan, any activity constituting prior use must take place in Japan.<sup>120</sup> This territorial requirement may also span territories owned by a particular country. For example, like Japan, France requires prior use to take place within its borders as well.<sup>121</sup> Since France also encompasses territories outside continental Europe, this area includes overseas departments such as French Polynesia, the Wallis and Futuna Islands, the French territories of the Southern Hemisphere, Antarctic, New Caledonia, and Mayotte.<sup>122</sup>

Denmark, France, Germany, and the United Kingdom are all members of the European Union. Therefore, it should be noted that some scholars have indicated that limiting the territorial scope of prior user rights to within the national borders of member states may contravene European Competition Law.<sup>123</sup>

The AIA is in harmony with all studied countries, as it provides that only commercial use in the United States may provide the basis for a prior use defense.<sup>124</sup>

Thus, the USPTO finds that:

**Finding 1: The AIA strikes the right balance by limiting the prior user rights defense to those parties that can prove commercial use at least one year prior to the filing date of the patent application by clear and convincing evidence.**

## **2. Scope of Prior User Rights Defense**

The scope of the prior user rights defense varies somewhat from country to country. The following is a summary and comparison of the scope of the defense, which in general is fairly consistent across the vast majority of the jurisdictions studied. The scope of the prior use defense can generally be

---

<sup>119</sup> See generally: U.K. Patent Act, at § 64; German Patent Act § 12; Danish Patents Act, at § 4(1); French Intell’l Prop. Law, at art. L613-7; Canadian Patent Act, at § 56(1); Brazilian Patent Law, at art. 45; Mexican IP Law, at Art. 22.III; Australian Patent Law, at § 119; Japanese Patent Act, at art. 79; Korean Patent Act, at art. 103; and Chinese Patent Law, at art. 69(2).

<sup>120</sup> Japanese Patent Act art. 79.

<sup>121</sup> French Intell’l Prop. Law, at art. L613-7.

<sup>122</sup> Pochart, *supra* note 56, at slide 3.

<sup>123</sup> Webb, *supra* note 65 at ¶¶ 7.1-7.3 (noting that the territorial requirement in U.K. may contravene European Competition Law by discriminating between acts carried on in different states of the EU).

<sup>124</sup> § 5, 125 Stat. at 297 (to be codified at 35 U.S.C. § 273(a)).

characterized as: (a) breadth of the prior use activities encompassed by the defense; (b) transferability of the prior use defense; and (c) limitations on enforceability of the defense.

**a. Breadth of the Prior Use Activities Encompassed by the Defense**

The breadth of the prior user activities among all the studied countries is fairly consistent. Generally, the prior user right laws of these countries protect or allow for the continuation of activity that was commenced before the effective filing of patent. While this “right” may be somewhat nuanced in its characterization (as either a defense, a non-exclusive license, or an exemption from liability), the practical effect is mostly uniform throughout the jurisdictions studied. The breadth of protection afforded to a prior user can be classified into one of the following three categories: (i) commensurate scope; (ii) broader scope; or (iii) narrower scope.

A little more than half of the studied countries require that the prior user limit any continued activity to a scope commensurate with the previous activity that triggered the prior user rights. For example, in Denmark, those claiming prior user rights may continue exploiting the invention as long as said exploitation “retain[s] its general character.”<sup>125</sup> In Brazil, prior users may “continue the exploitation, without onus, in the same manner and under the same conditions as before.”<sup>126</sup> Similarly, prior user rights in the Russian Federation provide “a right to proceed with [...] prior use free of charge, provided that the scope of the activity [...] is not extended.”<sup>127</sup> The same appears to be true for Australia,<sup>128</sup> Canada,<sup>129</sup> Mexico,<sup>130</sup> and China.<sup>131</sup>

A second group of the studied countries provide a broader scope of prior use activities. To be more accurate, the “broadening” is actually an extension of the original prior use activities to include any equivalents or variants of the original activity. For example, the Republic of Korea provides for prior

---

<sup>125</sup> Law No. 91 of 28 January 2009, Consolidate Patents Act, §4(1) (Denmark); *See also* PATRICK VAN EECKE ET AL., MONITORING AND ANALYSIS OF TECH. TRANSFER AND INTELL. PROP. REGIMES AND THEIR USE: RESULTS OF A STUDY CARDED OUT ON BEHALF OF THE EUROPEAN COMMISSION 104-105 (DG Research 2009) (noting that Denmark explicitly limits the extent of the prior user rights).

<sup>126</sup> Law No. 9.279 of 14 May 1996, Sec. II, art. 45 (Brazil) [hereinafter “Brazilian Patent Law”] (“A person who in good faith, prior to the filing or priority date of a patent application, was exploiting the object thereof in this country, shall be assured the right to continue the exploitation, without onus, in the same manner and under the same conditions as before . . .”).

<sup>127</sup> Russian Patent Law, § IV, art. 12.

<sup>128</sup> Australian Patent Law at § 119(5).

<sup>129</sup> Canadian Patent Act at § 56(1) (articulating that prior users have “the right to use and sell to others the specific article, machine, manufacture or composition of matter *patented* and so purchased, constructed or acquired without being liable to the patentee or the legal representatives of the patentee for so doing”).

<sup>130</sup> Mexican IP Law, at art. 22.III.

<sup>131</sup> Chinese Patent Law art. 69(2).

user rights in the form of a “non-exclusive license.” The breadth of this non-exclusive license is limited to “the scope of the objective of the invention or the business related to the invention that the person is working or making preparations to work.”<sup>132</sup> The prior user may expand the business based on the prior user right, and may change the mode of operation to the extent that those skilled in the art are expected to employ the changed mode.<sup>133</sup> Japan also has a similar provision.<sup>134</sup>

France and the United Kingdom also provide a broader scope for prior use activities, but do so in a different fashion. The prior user rights laws of the United Kingdom do not explicitly broaden the scope of activities afforded to a prior user, but only allow the prior user to continue with the “infringing acts.”<sup>135</sup> However, the United Kingdom’s case law has interpreted this to mean that the prior user may expand a business activity based on his/her prior user right and may change the mode of operation if such a change does not affect the essence of the invention.<sup>136</sup>

Similarly, the French prior user rights statute does not place any explicit limits on the scope of the prior user right.<sup>137</sup> However, French Courts have interpreted this legislation to broaden the scope of the personal right, such that it includes subject matter identical to the patented invention, as well as any equivalents of the patented invention.<sup>138</sup> It should be noted, however, that unlike the United Kingdom’s case law precedent, France’s case law is non-binding, as it is based on a civil law tradition.

The final category regarding the breadth of prior use activities include laws that actually narrow the scope of permissible prior use activities when compared to the triggering prior use. Germany is the only studied country with such laws. As previously discussed, Germany has a hybrid use-possession prior use system, in which a party must show either use of the invention or “necessary arrangements” to use the invention. This triggering activity is not circumscribed any further. However, once the benefit of prior user rights is afforded, a prior user must limit any continued use of the invention to “the needs of his own business in his own workshops or the workshops of others.”<sup>139</sup> That is to say, the scope of prior user rights is narrowed to exclude non-commercial activity and even commercial activity that is not related to the specific needs of a business. In Germany, a party that intends to continue infringing use, based on a

---

<sup>132</sup> Korean Patent Act at art. 103.

<sup>133</sup> Hiroo Maeda, *Seven New Frameworks for Protection and Management of Knowledge*, INST. INTELL. PROP. BULL. 50, 55 (2006), available at [http://www.iip.or.jp/e/e\\_summary/pdf/detail2005/e17\\_07.pdf](http://www.iip.or.jp/e/e_summary/pdf/detail2005/e17_07.pdf).

<sup>134</sup> Japanese Patent Act at art.79 (noting that the non-exclusive license is provided “only to the extent of the invention and the purpose of such business worked or prepared”).

<sup>135</sup> U.K. Patent Act, at § 64.

<sup>136</sup> VAN EECKE, *supra* note 125, at 104 (noting that legal doctrine of the U.K. provides that a prior user may expand into other products).

<sup>137</sup> VAN EECKE, *supra* note 125, at 104.

<sup>138</sup> Pochart, *supra* note 56, at slide 12.

<sup>139</sup> Patent Act (Germany), Dec. 16, 1980, BGBl. I at 1981, last amended by Gazette (Germany), July 31, 2009, BGBl. I at 2521, pt. 1, § 12 [hereinafter “German Patent Act”].

claim of prior user right, bears the burden of showing a nexus between said continued infringing activity and some particular business need.

The breadth of permissible prior use activities under the AIA is of a broadening nature, which is similar in about half of the studied countries. The AIA specifies that the prior user rights defense, “extends only to the specific subject matter for which it has been established that a commercial use [...] occurred.”<sup>140</sup> However, the provision goes on to state that “the defense shall also extend to variations in the quantity or volume of use of the claimed subject matter, and to improvements in the claimed subject matter that do not infringe additional specifically claimed subject matter of the patent.”<sup>141</sup> In permitting the prior user rights defense to be invoked even where there are variations in the quantity or volume of the use, the AIA permits a greater breadth of prior use activities than in some other jurisdictions.

### **b. Transferability of the Prior Use Defense**

In most jurisdictions, the prior use defense is limited to prior users and may only be transferred or assigned along with some or all of a business entity utilizing the prior user right. Prior user rights generally cannot be licensed, and as such, are typically treated as a personal right. The limits on transfer and prohibition of licensing keeps the prior use defense an equitable defense rather than an affirmative right. Among the studied countries, transferability of the prior user rights defense can be classified as: (i) transferable; (ii) transferable only with a business; (iii) transferable with either a business or a production unit; or (iv) not transferable.

Only one of the studied countries appears to have an unqualified transferability requirement. Prior user rights in Australia can be transferred to “successors in title.”<sup>142</sup> More specifically, Australian law permits assignment of prior user rights. However, prior user rights cannot be licensed by the prior user. Assignees are considered as “successors in title” while licensees are not considered as such because assignees are subsequent owners of rights.<sup>143</sup> Australian law does not articulate that there needs to be a nexus between assignment and a business unit of the original holder of the prior user rights.

Most of the studied countries permit the transfer of prior user rights if done in conjunction with the transfer of the business originally holding such a right. For example, Denmark limits the transfer of prior user rights by requiring that the right “shall only be transferred to others together with the business

---

<sup>140</sup> § 5, 125 Stat. at 298 (to be codified at 35 U.S.C. § 273(e)(3)).

<sup>141</sup> *Id.*

<sup>142</sup> Australian Patent Law, at § 119(4).

<sup>143</sup> IP Australia Submission, at 12-15.

in which it has arisen or in which the exploitation was intended.”<sup>144</sup> Germany<sup>145</sup> and China<sup>146</sup> have similar laws in this respect.

Japan also limits transfer of prior user rights to an assignment in conjunction with a business. However, Japan also provides other avenues of transfer. Generally speaking, Japanese prior user rights may be transferred whenever the business involving “the working of” the relevant invention is also transferred. But in addition to this, the prior user right may be transferred where the consent of the patent holder is obtained or where the transfer occurs as a result of general succession (including inheritance).<sup>147</sup> The same is true for the Republic of Korea.<sup>148</sup>

The third category is transferability of the right alongside a business or a production unit of said business. More specifically, rather than limiting conveyance of said prior user right to an assignment in conjunction with a whole business, said conveyance may include an assignment in conjunction with the particular business unit that is responsible for the triggering prior use activity. This type of transfer is actually of a lower threshold than the preceding category. For example, French prior user rights can “be transferred together with the business, the enterprise or the part of the enterprise to which it belongs.”<sup>149</sup> Transfer of prior user rights is also similarly restricted in the Russian Federation, where the right of a prior user “may be transferred together with the production unit in which actual use or necessary preparations for said use have been made.”<sup>150</sup> Brazil<sup>151</sup> has laws similar to France and the Russian Federation.

The United Kingdom also has similar but perhaps even more restrictive provisions on transfer of prior user rights as compared to France, the Russian Federation and Brazil. Prior users may assign or transmit their right upon death to any person who acquires that part of the business.<sup>152</sup> Furthermore, the

---

<sup>144</sup> *Id.* at § 4(2).

<sup>145</sup> German Patent Act, at § 12.

<sup>146</sup> Chinese Patent Law, at art. 69(2).

<sup>147</sup> Japanese Patent Act, Article 94(1); *see also* Yuichiro Nakaya & Gen Aida, Deputy Director & Assistant Director, Japan Patent Office, Submission re WIPO Questionnaire on Exceptions and Limitations to Patent Rights, 8-9, [http://www.wipo.int/export/sites/www/scp/en/exceptions/submissions/japan\\_rev.pdf](http://www.wipo.int/export/sites/www/scp/en/exceptions/submissions/japan_rev.pdf) (last visited Dec. 21, 2011).

<sup>148</sup> Maeda, *supra* note 133, at 55; *see also* Hyun-suk Lim, Senior Deputy Director, Korean Intell’l Prop. Office, Submission re Questionnaire on Exceptions and Limitations to Patent Rights, 8-9, [http://www.wipo.int/export/sites/www/scp/en/exceptions/submissions/rep\\_of\\_korea.pdf](http://www.wipo.int/export/sites/www/scp/en/exceptions/submissions/rep_of_korea.pdf) (A prior user right in the Republic of Korea can be transferred together with the business, in the case of inheritance or other general succession, or with consent of the patent holder).

<sup>149</sup> French Intell’l Prop. Law, at art. L613-7.

<sup>150</sup> Russian Patent Law, at art. 12.

<sup>151</sup> Brazilian Patent Law at art. 45(2) (under Brazilian law prior user rights “may only be assigned together with the business or company, or part thereof that is directly related to the exploitation of the object of the patent, by transfer or leasing.”)

<sup>152</sup> U.K. Patent Act, at § 64.

United Kingdom allows a prior user in a partnership to authorize his partners to perform the prior use activities.<sup>153</sup>

The final category bars the transfer of the prior user right. While Mexican law does not appear to explicitly address transfer of prior user rights, it is understood in practice that prior user rights are not transferable.<sup>154</sup> As such, prior user rights appear to be a purely personal and non-transferable right in Mexico.<sup>155</sup>

Finally, it should be noted that Canada was not classified into any of the categories above. As previously stated, Canada's prior user right encompasses the purchase, construction, or acquisition of claimed subject matter.<sup>156</sup> Therefore, any party in a product supply chain, or business transaction, may also be able to assert the prior user rights defense. However, it is not clear whether the right may be transferred to (and asserted by) someone outside of this nexus. Canadian law appears silent on this issue and Canadian case law does not appear to provide a definitive conclusion, with some suggesting that it is logical that they can be "passed on to another."<sup>157</sup>

Like most of the studied countries, the prior user rights defense under the AIA may be transferred as long as it is in conjunction with a business unit. More specifically, the AIA specifies that prior user rights can only be transferred, except to the actual patent owner, as part of a good faith assignment or transfer of the entire enterprise or line of business to which the defense relates.<sup>158</sup> That is, the right to assert said defense may not "be licensed or assigned or transferred to another person except as an ancillary and subordinate part of a good-faith assignment or transfer for other reasons of the entire enterprise or line of business to which the defense relates."<sup>159</sup>

### **c. Limitations on Enforceability of the Defense**

Under section 273(e)(5) of the AIA, a prior user right defense to infringement may not be asserted if "the claimed invention with respect to which the defense is asserted was, at the time the invention was made, owned or subject to an obligation of assignment to either an institution of higher

---

<sup>153</sup> VAN EECKE, *supra* note 125, at 105; *see also* Hazel Craven, Senior Legal Adviser, UK Intell'l Prop. Office, Submission re WIPO Questionnaire on Exceptions and Limitations to Patent Rights, 16-18, <http://www.wipo.int/export/sites/www/scp/en/exceptions/submissions/uk.pdf>; *and* Webb, *supra* note 65, at ¶ 6.

<sup>154</sup> Mexican IP Law, Art. 22.

<sup>155</sup> Fabian R. Salazar, Divisional Director for Patents, Mexican Institute for Indus. Prop., Submission re WIPO Questionnaire on Exceptions and Limitations to Patent Rights, 10, <http://www.wipo.int/export/sites/www/scp/es/exceptions/submissions/mexico.pdf>.

<sup>156</sup> Canadian Patent Act at § 56(1).

<sup>157</sup> Binkley at 208.

<sup>158</sup> § 5, 125 Stat. at 298 (to be codified at 35 U.S.C. § 273(e)(1)(B)).

<sup>159</sup> *Id.*

education... or technology transfer organization whose primary purpose is to facilitate the commercialization of technologies developed by one or more such institutions of higher education.”<sup>160</sup>

After studying the prior user rights provisions on the various selected countries across the globe, there appears to be no limitations on enforceability in any of their laws. In this regard, it appears that the United States is rather unique in including a provision benefiting the academic sector.

Thus, the USPTO finds that:

**Finding 2: The scope of the prior user rights defense includes limitations on the type of continued activities, the transfer of the personal rights, and the enforcement of said right, such that the patentee’s rights are not unjustly impinged and the university community may benefit, since the defense is not available in patent actions by universities.**

On the basis of the above analysis and findings, the USPTO recommends as follows:

**Recommendation 1: The prior user rights defense provisions set forth in the AIA are generally consistent with those of major trading partners and need not be altered at this time.**

**B. Impact of Prior User Rights on Innovation, Start-up Enterprises, Small Businesses, Individual Inventors and Universities**

The American Invents Act mandates that the USPTO conduct a prior user rights study, requiring the Office to conduct several inquiries related to economic activity.<sup>161</sup> This section addresses:

- (a) The effect of prior user rights on innovation rates in the selected countries;
- (b) If there is any correlation between prior user rights and start-up enterprises and the ability to attract venture capital to start new companies; and
- (c) The effect of prior user rights, if any, on small businesses, universities, and individual inventors.

Economic thought on the relationship of property rights and the incentives to engage in creative efforts like invention is well developed. Traditionally, economists have viewed patent rights as a solution

---

<sup>160</sup> § 5, 125 Stat. at 298-299 (to be codified at 35 U.S.C. § 273(e)(5)).

<sup>161</sup> §§ 3(m)1.B.-C., 125 Stat. at 292.

to a basic failure in the market for ideas.<sup>162</sup> It has been recognized that ideas and creativity – and the inventions that the human mind may produce – have a character like that of a public good. Unlike a private good, a public good suffers from an excludability problem – meaning that it is difficult to exclude others from appropriating the economic benefits from the creator. As a result, without intervention, inventions would tend to be produced at a level lower than what is socially optimal since – without some kind of legal protection – some if not all of the economic value from creativity would flow to copiers, and not to the creator. As a result, creators would have little incentive to invest substantial amounts of time and capital in inventing because there would be little prospect of recouping research and development expenses. Patent rights work to solve this problem by providing a legal excludability for a limited time to the inventor, and by so doing work to provide the appropriate economic incentive to inventors to make the investments necessary for society to enjoy new technologies.

That said, the exclusivity provided by society to inventors is not complete. The Constitution enshrines the basic economics underlying the kind of right that society ought to offer to the inventor – that the exclusive right be “limited” and that it be tied to other ends associated with the “progress of science and the useful arts.” Prior user rights tend to work against the excludability function of patents, but it is not clear from existing research how much and to what extent that may be a problem, even apart from the fact that existing research does not address the precise form of prior user rights provided under the AIA.

From an economic perspective, the availability of a prior user rights defense may offer both advantages and disadvantages. In terms of private benefits and costs, a preexisting inventor with a secret use of a later patented invention would be benefited by not being prevented from practicing the invention. Conversely, a later patenting inventor would be disadvantaged by having, at the margin, fewer opportunities to profit from the patented invention.

The benefits and costs to society, however, are more speculative, and will include the impact that the availability of the defense has at least upon innovation rates, the types of innovations that are produced, the speed and quality of that innovation, and the costs to consumers of the innovations available in the marketplace. These various costs and benefits are very unclear, and there is only limited economic research dealing with any of these implications.

Any meaningful disadvantages associated with the availability of the defense would be driven by two related effects: prior user rights could discourage actual innovation in society due to the lower economic returns available to inventors, and the defense could discourage the choice of patenting in relation to trade secret protection. Accordingly, it is relevant to ask whether any economic research has

---

<sup>162</sup> See, e.g., Kenneth J. Arrow, *Economic Welfare and the Allocation of Resources for Inventions*, in *THE RATE AND DIRECTION OF INVENTIVE ACTIVITY: ECONOMIC AND SOCIAL FACTORS* 609-625 (Nat'l Bureau of Econ. Research 1962).



tried to determine how large these two effects are in the aggregate (in other words, what is the impact on innovation, disclosure, and follow-on innovation).

The remainder of this section includes a discussion of the three specific economic questions posed by Congress in light of these considerations, the public comments received, and the existing scholarly research and economic analysis available.

## **Analysis and Findings**

### **1. Prior User Rights and Innovation Rates**

This section considers the economic impact of prior user rights defense as it relates to innovation rates. First, it reviews the extent of prior user rights available under the AIA. Second, it discusses economic research related to the patent system and prior user rights, and their likely impacts on innovation. It concludes by analyzing the existing empirical research on the impact of prior user rights and presents findings.

As a threshold matter, this section discusses the economic impact of a prior user rights defense on innovation rates in selected countries (the United States, members of the European Union, Japan, Canada, and Australia).<sup>163</sup> As observed in comments to the Federal Register Notice from two associations of intellectual property attorneys, country-specific information is limited, with only occasional economic studies that focus on particular jurisdictions.<sup>164</sup>

Historically, prior user rights were included in the U.S. patent law between 1836 and 1952, and as noted in comments submitted to the Request For Information (RFI), no evidence has been generated that shows prior user rights weakening innovation rates or economic growth during that time.<sup>165</sup> In fact, industries were born and grew to prominence during that era, both those like petroleum in which secrecy tends to be a relatively more effective means of protecting innovation, and those like pharmaceuticals in which patenting is relatively more effective at allowing innovators to profit from the creation of new

---

<sup>163</sup> *Id.*

<sup>164</sup> Comments from William G. Barber, President, Am. Intell'l Prop. Ass'n, to Elizabeth Shaw, IP Research Specialist Supervisor, USPTO, Office of Policy and External Affairs, Prior User Rights 4 (Nov. 8, 2011) [hereinafter "Comments of AIPLA"], [http://www.uspto.gov/aia\\_implementation/pur-2011nov08-aipla.pdf](http://www.uspto.gov/aia_implementation/pur-2011nov08-aipla.pdf); Comments of FICPI, *supra* note 40, at 4. The analysis considers that the impact of such a defense will tend to be roughly similar across nations that share similar innovation systems, economic structures, and technological distributions. Because the OECD nations tend to share these same general characteristics, these impacts are addressed in general terms, not on a country-by-country basis.

<sup>165</sup> *See generally* Comments of Microsoft Corp., *supra* note 43, at 6.

technologies.<sup>166</sup> A narrower prior user right was established by the American Inventors Protection Act of 1999 in section 273.<sup>167</sup> Since that time, it appears that only one case has been reported in which this defense has been raised.<sup>168</sup>

*The Economics of Patent Rights and Innovation.* There is very limited economic research on the incentive effects of a prior user rights defense and its impact on innovation. One economist used theoretical models to investigate these impacts, concluding that "[w]hen nearly simultaneous, independent invention occurs, awarding one inventor a patent and the other the right to use the invention has very attractive properties. Competition is enhanced, innovation is rewarded with relatively little deadweight loss, and the private and social incentives to be the sole versus joint inventor are generally better aligned than in the absence of such rights."<sup>169</sup> Another theoretical treatment concludes that independent invention defenses reduce entry into patent races, and thus reduce wasteful duplication, thereby preserving limited societal resources for other investments.<sup>170</sup>

Public comment to the Federal Register Notice was not consistent concerning the innovation impacts of allowing a prior use defense. Some members of the public warned of reduced innovation rates as a result of the availability of the defense: An organization representing patent owners said that prior user rights could harm innovation rates by reducing the confidence innovators have in the system of patent rights.<sup>171</sup> The same organization speculated that prior user rights may reduce the incentive to disclose innovations, by providing a form of protection for firms that maintain their innovations as trade secrets.<sup>172</sup>

In addition to newness, other characteristics of technology may play a role in the benefit and costs associated with a prior user defense. In some technologies characterized by numerous incremental inventions, it may not be feasible to patent every invention that a company is developing and using.

---

<sup>166</sup> See generally Wesley M. Cohen et al., *Protecting Their Intellectual Assets: Appropriability Conditions and Why U.S. Manufacturing Firms Patent (or Not)* (Nat'l Bureau of Econ. Research, Working Paper No. 7552 (2000)), available at <http://www.nber.org/papers/w7552>.

<sup>167</sup> 35 U.S.C. § 273.

<sup>168</sup> *Seal-Flex, Inc. v. W.R. Dougherty and Assocs.*, 179 F. Supp. 2d 735, 741-42 (E.D. Mich. 2002) (refusing to address the prior user defense on the basis that it was untimely raised). Some cases covered § 273 in an ancillary manner. See generally *Bilski v. Kappos*, 130 S. Ct. 3218, 3228-29 (2010) (pointing out that the existence of section 273 suggests that business methods are not categorically excluded from patent-eligibility); *Aristocrat Techs. Austl. PTY Ltd. v. Int'l Game Tech.*, 543 F.3d 657, 662 (Fed. Cir. 2008) (dicta on § 273); *PB Farradyne, Inc. v. Peterson*, 2006 U.S. Dist. LEXIS 67281, \*12 (N.D. Cal. 2006) (plaintiff abandons § 273 claim); *Sabasta v. Buckaroos, Inc.*, 2009 U.S. Dist. LEXIS 12754, \*3-\*2 (2009) (S.D. Iowa) (plaintiff briefly asserts § 273); *Powertech Tech., Inc. v. Tessera, Inc.*, 660 F.3d 1301, (Fed. Cir. 2011) (briefly discussing 273 in dicta).

<sup>169</sup> Carl Shapiro, *Prior User Rights*, 96 AMERICA ECON. REV. 92, 95 (2006).

<sup>170</sup> Stephen M. Maurer & Suzanne Scotchmer, *The Independent Invention Defense in Intellectual Property*, 69 ECONOMICA 535 (2002).

<sup>171</sup> Comments of Innovation Alliance, *supra* note 44.

<sup>172</sup> *Id.*

Comments made to the Federal Register Notice from two information technology companies said that patent protection is not the most efficient tool in some high-technology fields,<sup>173</sup> and that the patent system was not intended to force such firms to defensively patent everything.<sup>174</sup> Similarly, a pharmaceutical delivery company wrote that prior user rights were useful to defend against patents that provided only minor improvements and were used primarily to block generic competitors.<sup>175</sup>

The extent of benefits and harm flowing from the availability in the U.S. of a prior user rights defense is, in the end, an empirical question best answered by comprehensive data on the true impacts revealed over time. Unfortunately, formal statistical study of prior user rights has been extremely limited, largely because the full effect of this type of policy change is inherently difficult to measure. As a policy matter, the introduction of prior user rights often comes along with several other policy changes (as is the present experience of the United States in the AIA). A formal effort to measure whether the introduction of prior user rights affected innovation would thus be confounded by other policies changing simultaneously, which almost certainly also have an impact on innovation rates. Similarly, cross-country comparisons cannot effectively identify the effect of prior user rights, because prior user rights regimes often differ between countries, and countries always differ in many other ways, particularly in how their innovation systems are organized and the ways in which they operate.<sup>176</sup>

There is, however, some qualitative evidence available. There have been prior user rights in the United States for business method patents since the enactment of a 1999 law, but by all accounts this particular defense does not appear to have had a significant impact, either in industrial practice or in patent litigation. Also, the prior user rights available historically in the U.S. did not appear to have a significant impact on innovation.<sup>177</sup> Moreover, many countries have prior user rights in some form,<sup>178</sup> but their use in practice has been very limited.<sup>179</sup> Thus, after considering the available evidence, the USPTO finds that:

**Finding 3: There is no substantial evidence that prior user rights as established in the AIA will have a negative impact on innovation.**

---

<sup>173</sup> Comments from Verizon Comm. Inc., and Google, Inc., to the USPTO, Comments of Verizon Comm. Inc., and Google, Inc. on the Study of Prior User Rights under the Leahy-Smith America Invents Act 3 (Nov. 8, 2011) [hereinafter “Comments from Google and Verizon”], [http://www.uspto.gov/aia\\_implementation/pur-2011nov08-google\\_verizon.pdf](http://www.uspto.gov/aia_implementation/pur-2011nov08-google_verizon.pdf).

<sup>174</sup> *Id.* at 6.

<sup>175</sup> Comments of Hospira Inc., *supra* note 43.

<sup>176</sup> NATIONAL INNOVATION SYSTEMS: A COMPARATIVE ANALYSIS (Richard Nelson ed. 1993).

<sup>177</sup> See *supra* notes 165-168 and accompanying text.

<sup>178</sup> See Kupferschmid, *supra* note 9, at 252.

<sup>179</sup> VAN EECKE, *supra* note 125, at 106.

## 2. Prior User Rights and New Company Venture Financing

In order to report possible correlations between the exercise of a prior user rights defense and the ability of new firms to attract venture capital, it is necessary to determine the drivers of venture-capital investment in the entrepreneurial economy. Anecdotal evidence, including comments submitted by several respondents to the RFI, suggests that patenting is often a critical element in venture investors' decision of whether to fund a technology start-up. As a tangible right covering an intangible asset, a patent can convey key information to potential investors. Patents may thereby provide both (i) information that investors may use to project potential commercialization success and returns on investment, and (ii) exclusivity rights that investors may use in estimating future market size.

Economic scholarship supports the patent-investment relationship. One particular economic study examined the relationship between venture funding and patenting rates across twenty industries and three decades<sup>180</sup>, finding that venture funding was seven times more likely to stimulate patenting than was corporate R&D. The impact of venture capital on patenting rates for seed and early stage start-ups was especially significant, increasing the relative impact of a venture-funded dollar by 45% when compared to broader set of venture-funded firms. Overall, the study revealed that venture-backed firms were more likely than those without venture funding to engage in patenting, to have their patents cited, and to find themselves in "frequent and protracted litigation of both patents and trade secrets." Additionally, a growing body of research over the last ten years has indicated that patents are both important as selection criteria for venture capitalists<sup>181</sup> and are related to increased valuations for start-ups.<sup>182</sup> While many of the studies have focused on high-technology venture capitalists (VCs), who may value patent protection more strongly than in other sectors, this emphasis still aligns with the anecdotal evidence relating patent importance in valuation.

The core questions related to whether the availability of prior user rights negatively affect a start-up's ability to attract venture capital include: determining if potential use of these prior user rights is likely to either increase risk to or uncertainty for the venture capital investor; and to decrease the projected returns on investment.

---

<sup>180</sup> See generally Samuel Kortum & Josh Lerner, *Assessing the Contribution of Venture Capital to Innovation*, 31 RAND J. ECON. 674 (2000).

<sup>181</sup> Daniel Hoenig & Joachim Henkel, *Property Rights or Quality Signals? The Role of Patents in Venture Capital Financing*, 6th Annual Conf. of the EPIP Ass'n: Fine-Tuning IPR debates (2011), [http://www.epip.eu/conferences/epip06/papers/Parallel Session Papers/HOENIG Daniel.pdf](http://www.epip.eu/conferences/epip06/papers/Parallel%20Session%20Papers/HOENIG%20Daniel.pdf).

<sup>182</sup> See Joel A.C. Baum & Brian S. Silverman, *Picking Winners or Building Them? Alliance, Intellectual, and Human Capital as Selection Criteria in Venture Financing and Performance of Biotechnology Startups*, 19 J. BUS. VENTURING 411 (2003); Ronald J. Mann & Thomas W. Sager, *Patents, Venture Capital, and Software Start-Ups*, 36 RES. POL'Y 193 (2004).

While economic literature squarely addressing these questions is lacking, several public comments to the Federal Register Notice addressed the import of prior user rights to VC investment. Several respondents, including a prior director of a technology-focused Federal research organization,<sup>183</sup> asserted that prior user rights would create incentives for businesses to protect innovations through trade secrets instead of seeking patents. The implication is that the potential for secret uses in a market would make it more difficult for investors to estimate markets and value invention,<sup>184</sup> thereby depressing the attractiveness of a later patenting start-up to venture-capital funding. However, opinion was mixed on this question: One response by a major technology association which represents large, medium and small companies<sup>185</sup> suggested that, without the prior user rights defense, the company which lost the “race to the USPTO” in a first-to-file environment would lose all investment returns for that project. By avoiding such a harsh result in the particular case, the prior use right could provide venture capitalists with increased investment certainty.

A search of the existing economic literature yielded no empirical study of the impact of prior user rights within the U.S. venture-capital investment context, so correlations *per se* are not available. However, relevant information can be gleaned from a) identifying assertion rates and impacts of prior user rights in other countries, and b) assessing the degree to which trade secrets are already included in normal decision making by venture capital firms when making their start-up investments.

According to a recent European Commission study on prior user rights,<sup>186</sup> “very few cases involving prior use rights are brought to court [in Europe],” and questions posed to their stakeholders suggested that “the impact of prior use rights on patent litigation seem to be low.” Europe shares with the U.S. many of the economic characteristics that ought to be relevant in assessing the impact of a prior user rights defense in the U.S.: It is highly innovative, supports a strong patent system, and possesses well-developed capital markets and a large and vibrant competitive environment. It is noteworthy, however, that Europe tends to have a less well-developed entrepreneurship, start-up, and venture-investing environment than does the U.S.

---

<sup>183</sup> Comments from Tony Tether, to David Kappos et al., Undersecretary Dep. of Comm. for Intell. Prop., and Director of the USPTO 4 (Nov. 4, 2011) [hereinafter “Comments of Tony Tether”], [http://www.uspto.gov/aia\\_implementation/pur-2011nov07-tony\\_tether.pdf](http://www.uspto.gov/aia_implementation/pur-2011nov07-tony_tether.pdf).

<sup>184</sup> See Ellen Jalkut & Michael J. Remington, *Prior User Rights Expansion: Congress, the Courts, and Constitutional Considerations*, 82 BNA PAT., TRADEMARK, & COPYRIGHT J., Sept. 2, 2011, at 9, available at [http://www.drinkerbiddle.com/files/Publication/cbeafa8f-1b3b-4787-9fb8-17739e59dca9/Presentation/PublicationAttachment/8ddaed5-a6e9-4c30-b7af-1b8ff12f0a7e/ITN\\_Remington\\_BNA.pdf](http://www.drinkerbiddle.com/files/Publication/cbeafa8f-1b3b-4787-9fb8-17739e59dca9/Presentation/PublicationAttachment/8ddaed5-a6e9-4c30-b7af-1b8ff12f0a7e/ITN_Remington_BNA.pdf).

<sup>185</sup> Comments from Brian Kahin, Senior Fellow, Computer & Comm. Indus. Ass’n, to the USPTO, Comments of the Computer & Commc’ns. Ind. Ass’n (Nov. 8, 2011) [hereinafter “Comments of the Computer & Commc’ns. Ind. Ass’n”] [http://www.uspto.gov/aia\\_implementation/pur-2011nov08-ccia.pdf](http://www.uspto.gov/aia_implementation/pur-2011nov08-ccia.pdf).

<sup>186</sup> See VAN EECKE, *supra* note 125.

While Europe’s experience with prior user rights may suggest that the U.S., too, will experience few impacts from the adoption of the defense, these data are not complete. Without the benefit of empirical evidence, it will not be possible to make determinations before U.S. companies have had a chance to exercise these rights, and legal precedent is developed as to when a prior use defense may validly be supported. Clarification of the extent of subject matter upon which a prior user rights defense can be exercised, specifically with regard to other commercial processes may ultimately help VC investors better estimate the risk of prior users actually affecting the return on their investments.

The best available evidence shows, however, that the U.S. venture-capital investment environment has grown and thrived in a context of uncertainty over property rights in innovation, especially as regards patents and trade secrets. In a survey conducted at Carnegie-Mellon University in the early 1990s by Wesley Cohen and coauthors, these researchers found that among U.S. manufacturing firms, the majority of industries studied considered secrecy as an effective means of appropriating returns from innovations.<sup>187</sup> The importance of secrecy to protecting innovation by U.S. companies since the early 1990s suggests that venture-capital firms have long experience estimating the risk in a competitive environment that contains a large number of trade secrets. Academic research conducted in 2008 reported on one experienced VC who said that:

[w]hen thinking about the life-cycle of a company, in many respects the value of the IP is really generally assessed at the early stage by the first stages of “professional” money. These early-stage [professional investors] will do a great deal of scrutiny of IP of all types, but especially of trade secrets and patents.<sup>188</sup>

Such research suggests that investors have experience navigating the complexities of patenting and secrecy used by innovators in making investment decisions. Moreover, if prior user rights are likely to be rarely exercised in the U.S. (as is suggested by the European experience), then it is reasonable to conclude that “switching” from patent to trade secret protection as a result of the availability of this defense may be limited in nature.

Thus, after considering the available evidence, the USPTO finds that:

**Finding 4: There is no substantial evidence that prior user rights as established in the AIA will have a disproportionately negative impact on venture-capital investments to small businesses and start-ups.**

---

<sup>187</sup> See Cohen, *supra* note 166.

<sup>188</sup> Stuart J.H. Graham et al., *High Technology Entrepreneurs and the Patent System: Results of the 2008 Berkeley Patent Survey*, 24 BERKELEY TECH. L.J. 1255, 1305 (2009) (quoting a venture-capital investor).

### 3. **Prior User Rights and Small Businesses, Universities, and Individual Inventors**

Due to inclusion of the America Invents Act university exception,<sup>189</sup> whereby the prior user rights defense cannot be asserted for inventions that were “made, owned, or subject to an obligation of assignment to either an institution of higher education ... or a technology transfer organization” which was primarily linked to higher education institutions, the potential impact of the defense on universities is more limited. Accordingly, this Report considers the impact of prior user rights upon universities separately from the impact on small businesses and inventors in the foregoing analysis.

#### a. **Impact on Universities**

Since the Bayh-Dole Act of 1980 changed the way in which universities and federally supported research laboratories interact with the patent system, a substantial body of economic research has developed investigating this relationship.<sup>190</sup> While this literature examines the impacts on university-sponsored invention and innovation in the wake of the increased opportunities for patenting, licensing, and commercialization of federally funded research ushered in by the Bayh-Dole Act, this research does not specifically deal with the relationship of U.S.-university patenting to the availability of a prior user right defense.

As mentioned previously, while prior user rights exist in all EU member states (except Cyprus),<sup>191</sup> reports show that there is a very low incidence of associated litigation. Furthermore, review of the scholarly literature did not reveal any study explicitly assessing the impact of prior user rights to institutions of higher education in Europe. It is not surprising that, given the low incidence of prior user rights cases generally, empirical studies on the impacts on a subset of innovative activity – the universities – from these countries is not readily available. Furthermore, public comments on the topic generally reflected a lack of data and anecdotal accounts of any negative impacts upon universities. For instance, a comment to the Federal Register Notice from one large multinational company explicitly indicated that the company was unaware of any “evidence that universities in [European] countries had been negatively impacted by prior user rights.”<sup>192</sup> Comments to the Federal Register Notice from a German patent attorney went further, noting a lack of negative effects, explaining that “small businesses, universities, and individual inventors in Germany are frequently SMEs, remote from the patent system,”

---

<sup>189</sup> § 5, 125 Stat. at 292, 297-299 (2011).

<sup>190</sup> See generally David C. Mowery & Bhaven N. Sampat, *The Bayh-Dole Act of 1980 and University Industry Technology Transfer: A Model for Other OECD Governments?*, 30 J. TECH. TRANSFER 115 (2005).

<sup>191</sup> VAN EECKE, *supra* note 125.

<sup>192</sup> Comments of Microsoft Corp., *supra* note 43.

and that prior user rights protected their “legitimate know-how [from being] taken away.”<sup>193</sup> Because many U.S. universities have a more direct involvement with the patent system, as often do their licensee start-up companies, this example from Germany may have less relevance to the U.S. case.

Commentary to the Federal Register Notice offered by several higher education associations<sup>194</sup> as well as a university-linked patent management organization,<sup>195</sup> expressed concerns about possible negative effects that a future strengthening of prior user rights could have upon innovation at universities in the US. These respondents recognized that prior user rights may be important in particular technology sectors, particularly those in which “complex products and manufacturing processes” may make it difficult to patent every component. However, they also expressed concern that extending prior user rights into the university arena could create disincentives for information disclosure and collaboration in the university environment (for instance, through peer-reviewed journals and conference presentations). Since innovations from universities tend to be basic research, early-stage, and highly risky, these responding associations expressed a concern that allowing prior use rights in the university environment could “expand the pool of trade secrets immune from assertion of patent rights,” thereby reducing the certainty over what a patent excludes and discouraging private companies from licensing university patents.<sup>196</sup>

Congress mandated that all university and university-associated technology transfer organizations’ patents will be exempted from the availability of a prior user rights defense (excepting non-Federally funded activities).<sup>197</sup> Accordingly, the associations’ joint comments assert that the Act “effectively balances the concerns and interests of universities and private sector companies ... while inhibiting the development of a massive pool of trade secrets immune from the assertion of patent rights, as well as ... products that could be derived from early disclosures.”<sup>198</sup> In summation, because prior user rights (and the university exclusion) have only recently been permitted to be widely available here in the U.S., there is insufficient evidence at this time to determine the impact on universities.<sup>199</sup>

---

<sup>193</sup> Comments of Freischem, *supra* note 39.

<sup>194</sup> Comments from Various Higher Educ. Ass’n to the USPTO, Higher Educ. Comments on Prior User Rights 2 (Nov. 8, 2011) [hereinafter “Comments of Various Higher Educ. Ass’n”], [http://www.uspto.gov/aia\\_implementation/pur-2011nov08-higher-education-associations.pdf](http://www.uspto.gov/aia_implementation/pur-2011nov08-higher-education-associations.pdf).

<sup>195</sup> Comments from Carl E. Gulbrandsen, Managing Director, Wis. Alumni Research Found., to Elizabeth Shaw, IP Research Specialist Supervisor, USPTO, Office of Policy and External Affairs, In the Matter of Notice of Public Hearing and Request for Comments on Study of Prior User Rights 5-6 (Nov. 3, 2011) [hereinafter “Comments of Wis. Alumni Research Found.”], [http://www.uspto.gov/aia\\_implementation/pur-2011nov04-wisconsin\\_alumni\\_research\\_foundation.pdf](http://www.uspto.gov/aia_implementation/pur-2011nov04-wisconsin_alumni_research_foundation.pdf).

<sup>196</sup> Comments of Various Higher Educ. Ass’n, *supra* note 194.

<sup>197</sup> § 5, 125 Stat. at 292, 297-299.

<sup>198</sup> Comments of Various Higher Educ. Ass’n, *supra* note 194.

<sup>199</sup> *See* Comments of AIPLA, *supra* note 164.



Thus, after considering the available evidence, the USPTO finds:

**Finding 5: There is an insufficient basis to recommend a change to the scheme chosen by Congress with respect to the application of prior user rights to universities.**

**b. Impact on Small Business and Individual Inventors**

It is noteworthy that, as observed elsewhere in this study, evidence suggests that where prior user rights are available around the world, they are rarely used. These rights are rarely litigated in Europe,<sup>200</sup> in other countries where available around the world,<sup>201</sup> or under the business method version of prior user rights in the United States.<sup>202</sup> Indeed, in the case of business method patents in the United States, the prior user defense appears never to have been successfully raised since the enactment of the defense.<sup>203</sup> Since business methods are particularly prone to prior and independent invention,<sup>204</sup> such evidence of non-assertion may be particularly persuasive.

While scholarly research on the relationship of prior user rights defenses to small-business and independent-inventor incentives and performance is very limited, a few articles have been written. The scholarship is contradictory, however; some legal scholars raise a concern that small businesses may be harmed by the availability of a prior user rights defense, but other commentary suggests the contrary. One scholar has noted that it may be impossible to tell whether a possible infringer has prior user rights without expensive litigation that small businesses and independent inventors cannot afford.<sup>205</sup> Another suggested that small businesses would be unable to take advantage of the defense; small entities may have little or no manufacturing capabilities, and adopt licensing-only approaches, and thus are relatively unable to assert prior user rights.<sup>206</sup>

---

<sup>200</sup> VAN EECKE, *supra* note 125, at 106.

<sup>201</sup> Kupferschmid, *supra* note 9, at 226.

<sup>202</sup> Comments from Paul Morgan, PTO Requested Comments on the AIA “Prior Commercial Use” Defense Legislation (Oct. 13, 2011) [hereinafter “Comments of Paul Morgan”], [http://www.uspto.gov/aia\\_implementation/pur-2011oct13-paul\\_morgan.pdf](http://www.uspto.gov/aia_implementation/pur-2011oct13-paul_morgan.pdf).

<sup>203</sup> *Id.*

<sup>204</sup> See generally, Rochelle Cooper Dreyfuss, *Are Business Method Patents Bad for Business?*, 16 SANTA CLARA COMPUTER & HIGH TECH. L.J. 263 (2000).

<sup>205</sup> Edward L. MacCordy, *The Threat of Proposed Patent Law Changes to the Research University*, 20 J.C. & U.L. 295, 303 (1994).

<sup>206</sup> Chris P Konkol, *Prior-Invention Rights: The Excluded Middle*, 77 J. PAT. & TRADEMARK OFF. SOC’Y 666, 670 (1995); Kupferschmid, *supra* note 9, at 234.

On the other hand, other scholarship has noted potential benefits to small businesses flowing from the defense. For example, some entities may license their rights to manufacturing or marketing firms, which themselves may qualify for prior user rights. If the licensing entity fails to obtain a patent—for example, because after the license it is discovered another entity filed first—its licensees may be able to continue to use the licensed technology, through prior user rights.<sup>207</sup>

In addition, not all small entities will adopt patent-oriented innovation strategies. Some companies invest in production facilities immediately, and given limited funding, may not be able to both pursue a growth strategy and patent their innovations simultaneously. Prior user rights may be a useful defense to these small entities. Indeed, to the extent that prior user rights disproportionately affect small entities, they may benefit due to their greater difficulty in patenting, especially in light of the fact that small firms might not have the resources to pay for litigation to enforce their patents.

Public comments to the Federal Register Notice on the impact of prior user rights legislation upon small businesses and inventors were diverse and did not present a coherent answer to the questions presented by Congress. Some comments supported the position that prior use rights do not have a harmful effect on small businesses and independent inventors, and others suggested that harsh economic effects may flow from the availability of the defense.

Joint comments submitted by six higher education associations<sup>208</sup> suggested that complex manufacturing and products may require hundreds (or thousands) of potentially patentable components, and that prior user rights in the commercial world could help innovators defend against a patent acquisition company. Such a company may pursue a strategy of not manufacturing, but instead attempting to extract profits from companies. In this way, a manufacturer could be forced to stop all production if it chose to leave a small component of an otherwise complex product unpatented.<sup>209</sup> A small business manufacturer could be affected by such an outcome. More commonly, however, small businesses will be component suppliers to larger manufacturers, and such an outcome would stop production at the larger company, thus affecting the small component supplier as well. Two major technology companies, each of which purchase components from many small businesses, stated that it simply was not feasible to patent every component and process involved in highly complex technology sectors, and that these large producers should not be penalized if another entity patented a portion of the processes they were previously using.<sup>210</sup>

---

<sup>207</sup> Kupferschmid, *supra* note 9, at 234.

<sup>208</sup> Comments of Various Higher Educ. Ass'n, *supra* note 194.

<sup>209</sup> *Id.*

<sup>210</sup> Comments of Verizon Communications Inc. and Google Inc., *supra* note 173.

Furthermore, a major communications association asserted that any lack of prior user rights in a first-to-file system, would “compel firms to aggressively seek patents on minor improvements despite the very limited public benefit.”<sup>211</sup> In such a defensive “race to patent,” even small innovations could increase patent filings with negative impacts on all innovators who wish to use a timely patent system, while decreasing the quality of the patents requested.

A group of green technology companies stated that they often maintain key innovations as trade secrets in order to defend their competitiveness, because it can be very difficult to detect if others use their patented processes (especially in an international manufacturing environment).<sup>212</sup> In this situation, they suggested that prior user rights would not create incentives to increasingly rely on trade secrets; instead it would decrease the risk of an external patent affecting the processes already in use. Similar sentiments came from a space transportation company, which relies on trade secrets in order to protect innovations from being copied outside of the U.S.<sup>213</sup> Additionally, both testimony<sup>214</sup> and submitted comments<sup>215</sup> from individuals in the IP law arena suggested that the prior user rights being available outside, but not inside, the U.S. could lead to the exporting of manufacturing. The degree to which such exporting affects large versus small companies was not explored.

Other comments collected during the Federal Register Notice and public hearing process suggested that small businesses and independent inventors would be harmed by the availability of the defense in the U.S. Comments from an independent inventor stated that most start-ups and inventors will not meet the America Invents Act requirement to have used their innovation commercially for at least one year.<sup>216</sup> Because inventors often sell their technology directly to larger companies, they will not meet the commercial practice requirement. Furthermore, very early stage start-ups will not have existed long enough to meet the one year requirement.<sup>217</sup> Accordingly, large companies will be advantaged, and have a competitive, low-cost benefit in the Act for which many small, fast-moving, innovative companies would not qualify. Even if true, it is not clear how this result would tend to undermine the performance of small companies, or to leave them in a position worse off than the one they held prior to the signing of the Act.

---

<sup>211</sup> Comments of the Computer & Commc’ns. Ind. Ass’n, *supra* note 185.

<sup>212</sup> Comments of Greentech, *supra* note 47.

<sup>213</sup> Comments of Space Exploration Techs. Corp., *supra* note 47.

<sup>214</sup> Testimony of Thomas Kowalski, *supra* note 47; Gary Griswold, Consultant and Chair Emeritus of the Coalition for 21st Century Patent Reform, Comments at the Public Hearing on the Study of Prior User Rights 12-13 (Oct. 25, 2011) [hereinafter “Testimony of Gary Griswold”], [http://www.uspto.gov/aia\\_implementation/20111025-prior-user-rights-transcript.pdf](http://www.uspto.gov/aia_implementation/20111025-prior-user-rights-transcript.pdf).

<sup>215</sup> Comments of the Computer & Commc’ns. Ind. Ass’n, *supra* note 185.

<sup>216</sup> § 5, 125 Stat. at 297-299.

<sup>217</sup> Comments from Neil Thomas, to the USPTO, Prior User Rights 1 (Nov. 8, 2011) [hereinafter “Comments of Neil Thomas”], [http://www.uspto.gov/aia\\_implementation/pur-2011nov08-neil\\_thomas.pdf](http://www.uspto.gov/aia_implementation/pur-2011nov08-neil_thomas.pdf).

The director of a major federally funded lab echoed the assertion, reported elsewhere in this document, that “small innovative firms produce proportionately more, higher quality patents than large firms and they rely more heavily on patents to protect their innovations.”<sup>218</sup> Claiming that the defense increases uncertainty over patent value and exclusivity,<sup>219</sup> it was suggested that prior use rights will have a disproportionate impact upon the economic performance of small businesses.

As a result of these differences of opinion, there did not appear to be agreement among the comments. As was the case in the university context, because prior user rights have only recently been made widely available, other respondents stated that there is insufficient evidence at this time to determine the impact on small business and innovators.<sup>220</sup>

Accordingly, after considering the available evidence, USPTO finds that:

**Finding 6: There is no substantial evidence that the prior user right defense established by the AIA will have a negative impact on small businesses or independent inventors.**

On the basis of the above analysis and findings, the USPTO recommends:

**Recommendation 2: The prior user right defense under the AIA should be maintained with no change at the present time because there is no substantial evidence that it will have a negative impact on innovation, venture funding, small businesses, universities, or independent inventors.**

**Recommendation 3: The USPTO should reevaluate the economic impacts of prior user rights as part of its 2015 report to Congress on the implementation of the AIA, when better evidence as to these impacts might be available.**<sup>221</sup>

### **C. Analysis of Legal and Constitutional Issues with Placing Trade Secret Law in Patent Law**

The patent grant is derived from the Constitution, which authorizes Congress to secure to inventors the exclusive right to their discoveries.<sup>222</sup> Patent protection encourages individuals to apply their creative genius to producing new inventions by rewarding inventors exclusive control over their

---

<sup>218</sup> See Comments of Tony Tether, *supra* note 183.

<sup>219</sup> Jalkut, *supra* note 184.

<sup>220</sup> Comments of AIPLA, *supra* note 164.

<sup>221</sup> § 26, 125 Stat. at 338.

<sup>222</sup> U.S. CONST. art. I, § 8, cl. 8.

inventions for a limited time. In exchange for these exclusive rights, the patent holder is required to disclose to the world how that invention is made and used.<sup>223</sup> Because a prior use defense is viewed as an exception to the right of an inventor to exclude others from making and using the claimed invention, some have questioned the legal basis for such a defense. This section will offer an analysis of the legality of a prior use defense in United States patent law along with an analysis of the relationship between trade secret law and patent law.

In response to the Federal Register Notice requesting comments on the operation and impact of the prior user rights defense on patent infringement, the vast majority of respondents supported a prior use defense in United States patent law and did not address the legality of the prior use provision in the AIA. Of those who did address the legality of the provision, the majority did not express any concerns.<sup>224</sup>

In the majority view, there are no constitutional issues associated with adopting a prior user rights defense. The majority asserted that the Supreme Court previously addressed the compatibility of trade secret and patent laws in *Kewanee Oil Co. v. Bicron Corp.*, sanctioning the co-existence of two.<sup>225</sup> The majority also asserted that the prior use defense has existed in the United States prior to the 1952 Patent Act, and was not deemed unconstitutional or even challenged based on constitutionality.<sup>226</sup> Additionally, some companies indicated that they should not be forced to disclose discoveries, which, even if patented, could be copied by others.<sup>227</sup>

---

<sup>223</sup> Rebecca S. Eisenberg, *Patents and the Progress of Science: Exclusive Rights and Experimental Use*, 56 U. CHI. L. REV. 1017, 1022 (1989).

<sup>224</sup> See, e.g., Comments of AIPLA, *supra* note 164, at 4 (“AIPLA does not believe that there are any legal or constitutional issues raised by the proposal to implement a prior inventor rights system, with the appropriate limitations as presently exist.”); Testimony of Thomas Kowalski, *supra* note 47, at 15 (“The extent of the exclusivity of patent rights is among other things within Congress’s discretion. . . . I do not see the prior user rights defense as granting any rights but only defining contours of the exclusivity granted by a patent.”); Comments of the Computer & Commc’ns. Ind. Ass’n, *supra* note 185, at 3 (“Most arguments against prior user rights focus on the public disclosure function of the patent system—the principle that the patentee receives a limited monopoly in return for disclosing new knowledge to the public. Prior user rights do not change this basic *quid pro quo*.”); See generally Comments at the Public Hearing on the Study of Prior User Rights (Oct. 25, 2011), [http://www.uspto.gov/aia\\_implementation/20111025-prior-user-rights-transcript.pdf](http://www.uspto.gov/aia_implementation/20111025-prior-user-rights-transcript.pdf); and Comments on the Study of Prior User Rights, *supra* note 33.

<sup>225</sup> Comments of AIPLA, *supra* note 164, at 4 (noting that the “U.S. Supreme Court addressed the compatibility of trade secret and patent laws in *Kewanee Oil Co. v. Bicron Corp.*, 416 U.S. 470 (1974), based upon the common goal of encouraging the development of new inventions.”).

<sup>226</sup> Testimony of Thomas Kowalski, *supra* note 47 at 15-17 (noting that: (i) Congress has the power to define the right of exclusivity of a patent, and (ii) that a prior user rights defense existed in the U.S. prior to the 1952 Patent Act).

<sup>227</sup> See, e.g., Comments from Google and Verizon, *supra* 173, at 3-6 (“[T]he courts and the PTO have long recognized that innovation is best served by giving companies the freedom ‘to choose . . . the most commercially sound approach to commercially exploiting’ their innovations.”); Comments of Space Exploration Techs. Corp., *supra* note 47, at 2 (“At SpaceX, we believe that we must protect many of our innovations as trade secrets. . . . Due to well-known difficulties associated with enforcing patent rights in certain foreign jurisdictions, patents alone

A minority of respondents asserted that the prior user rights defense may be unconstitutional.<sup>228</sup> According to the minority view, the prior user right defense impedes the goal of the Constitution, “to promote the progress of science and the useful arts”<sup>229</sup> by encouraging inventors to keep their ideas secret.<sup>230</sup> Further, the minority also raised concerns about protecting trade secrets at the expense of patent rights.<sup>231</sup>

## **Analysis and Findings**

### **1. Constitutional Analysis of Prior User Rights**

Prior user rights are not unconstitutional. Instead, they comport with the Patent Clause of the Constitution, are consistent with the Patent Statute, and are supported by public policy considerations. Each is discussed, in turn. The Patent Clause<sup>232</sup> was “written against the backdrop” of the abuses of monopoly power; thus, Congress’s ability to grant patents was intended to be limited.<sup>233</sup> The Patent Clause is aimed at rewarding exclusivity on those who create new inventions, but it does not prevent protecting prior users from liability for infringement to one who elects to secure a later patent. The Patent Clause is silent regarding prior users.

Accordingly, after the framers established the Patent Clause, later Congresses created prior user rights in the United States. The prior user right defense has existed in United States patent laws for over a hundred years, between 1839 and 1952 and then again after 1999.<sup>234</sup> Section 7 of the 1839 Patent Act stated that any person who constructed or purchased a new invention prior to the patent application for that invention had the right to use and sell that invention without liability to the patent holder.<sup>235</sup> This

---

cannot adequately protect our technology. Moreover, patent specifications provide a roadmap to our unique technological advancements.”).

<sup>228</sup> See generally Comments on the Study of Prior User Rights, *supra* note 33.

<sup>229</sup> See, e.g., Comments of Wis. Alumni Research Found, *supra* note 195, at 2-5.

<sup>230</sup> See *id.* and Comments of Neil Thomas, *supra* note 217, at 2 (“The prior user rights provision seems to fly directly in the face of Art 1, Sec. 8, because the whole intent of the Founding Fathers was to encourage disclosure to society of new ‘discoveries’ by granting exclusive rights [...].”).

<sup>231</sup> See, e.g., Comments of Tony Tether, *supra* note 183, at 2 (“There is something fundamentally unfair about allowing something that is secret to erode a patent right.”).

<sup>232</sup> U.S. CONST. art. I, § 8, cl. 8.

<sup>233</sup> *Graham v. John Deere Co.*, 383 U.S. 1, 5-6 (1966).

<sup>234</sup> See *Eldred v. Ashcroft*, 537 U.S. 186, 199-205 (2002) (considering the history of copyright terms in evaluating the constitutionality of copyright law).

<sup>235</sup> Act of 1839, ch. 88, § 7, 5 Stat. 353, 354 (repealed 1952) (“That every person or corporation who has, or shall have purchased or constructed any newly-invented machine, manufacture, or composition of matter, prior to the application by the inventor or discoverer of a patent, shall be held to possess the right to use and vend to others to be used, the specific machine, manufacture, or composition of matter, so made or purchased, without liability therefore to the inventor, or any other person interested in such invention; and no patent shall be held invalid by reason of

provision was revised from time-to-time and was ultimately repealed in 1952 as “unnecessary and redundant.”<sup>236</sup> In 1999, in the wake of a Federal Circuit decision that confirmed the patentability of business methods,<sup>237</sup> a prior use defense was added solely to protect prior users of business methods.<sup>238</sup>

Further, Congress has imposed numerous other limits on a patent holder’s monopoly, such as limiting the term of the patent monopoly, granting the power of eminent domain over patents, imposing limitations to prevent patent misuse, and restricting the scope of reissued patents, to name a few. The prior user right defense is another limitation on patent rights.

Finally, policy considerations support a prior user rights defense. In analyzing the constitutionality of the prior use defense it is imperative to evaluate whether such a defense would be considered a “rational exercise” of Congress’s legislative authority.<sup>239</sup> Testimony in the Congressional Record suggests that the prior use defense was intended to protect jobs by allowing companies who invented a manufacturing process to continue using that process.<sup>240</sup> Additionally, there is testimony that the prior use defense would relieve manufacturers of the burden of seeking patent protection for every manufacturing process they use, which could number in the hundreds or thousands.<sup>241</sup> There is also testimony that companies should not be forced to seek patent protection if the risks of copying due to disclosure in a patent outweigh the benefits of United States patent protection.<sup>242</sup> Finally, there is testimony that a prior use defense would put the United States on equal footing with foreign countries, most of whom have a prior use defense.<sup>243</sup>

---

such purchase, sale, or use prior to the application for a patent as aforesaid, except on proof of abandonment of such invention to the public, or that such purchase, sale, or prior use has been for more than two years prior to such application for a patent.”); *see also McClurg v. Kingsland*, 42 U.S. 202, 208-09 (1843) (“The object of this provision is evidently twofold; first, to protect the person who has used the thing patented, by having purchased, constructed, or made the machine, etc., to which the invention is applied, from any liability to the patentee or his assignee. Second, to protect the rights, granted to the patentee, against any infringement by any other persons. . . . [I]t puts the person who has had such prior use on the same footing as if he had a special license from the inventor to use his invention; which, if given before the application for a patent, would justify the continued use after it issued without liability.”).

<sup>236</sup> H.R. REP. NO. 1923, 82d Cong., Table 3, at 72 (1952).

<sup>237</sup> *See generally State Street Bank & Trust Co.*, 149 F.3d at 1368.

<sup>238</sup> American Inventor Protection Act of 1999, 35 U.S.C. § 273 (repealed and replaced by Leahy-Smith America Invents Act, § 5, 125 Stat. at 297-299).

<sup>239</sup> *See, e.g., Eldred*, 537 U.S. at 204-208.

<sup>240</sup> Cong. Rec. H4483 (daily ed. June 23, 2011) (statement of Rep. Lamar Smith).

<sup>241</sup> *Id.*

<sup>242</sup> *Id.* at 4492 (daily ed. June 23, 2011) (statements of Reps. Lamar Smith and Zoe Lofgren); Cong. Rec. S5426-27, 5430, 5540 (daily ed. Sept. 8, 2011) (statements of Sens. Roy Blunt, Patrick Leahy, Jon Kyle).

<sup>243</sup> Cong. Rec. H4483 (statement of Rep. Lamar Smith). *See also Eldred*, 537 U.S. at 205-206 (citing as a legitimate purpose the goal of Congress to harmonize United States copyright laws with European copyright laws “so that American authors would receive the same copyright protection in Europe as their European counterparts”).

Thus, the USPTO finds that:

**Finding 7: A prior use defense to patent infringement is Constitutional and lawful and the defense is consistent with the Constitution and Supreme Court precedent recognizing that trade secret law and patent law can and do legally co-exist in the United States, and indeed have co-existed since our Constitution was created.**

## **2. The Relationship between Trade Secret Protection and Patent Law**

Somewhat related to the issue of the legality of the interplay between trade secret protection and patent law is whether a prior use defense to patent litigation strikes the appropriate balance between the two forms of intellectual property protection. One of the goals of the patent system is to enrich the fund of human knowledge through the timely disclosure of new technologies; trade secrets, by their very nature, do not accomplish this goal.<sup>244</sup> Some of the comments contend that providing prior user rights thwarts the aims of the patent system by favoring secrecy over disclosure.<sup>245</sup> The comments further argued that the grant of “co-exclusive rights” between the prior user and the patentee erodes the value of patents.<sup>246</sup> The problem, however, as pointed out in many of the comments, is that the patent system may not provide the right economic or strategic fit for each class of innovator or for each type of invention.<sup>247</sup>

Several of the comments noted that it is not economically feasible for certain businesses, particularly small- and medium-sized enterprises, to seek patent protection for every innovation they make.<sup>248</sup> For this class of innovators, a trade secret may be a cheaper alternative to a patent, one that

---

<sup>244</sup> See Kupferschmid, *supra* note 9, at 231 (addressing the argument that favoring trade secrets undermines the disclosure inducement theory underlying the patent system).

<sup>245</sup> See Comments of Wis. Alumni Research Found., *supra* note 195, at 2-3; Comments from P. Martin Simpson, Jr., Managing Counsel, Regents of the Univ. of Cal., to Elizabeth Shaw, IP Research Specialist Supervisor, USPTO, Office of Policy and External Affairs, Prior User Rights Written Comments 1 (Nov. 7, 2011), [http://www.uspto.gov/aia\\_implementation/pur-2011nov07-university\\_of\\_ca.pdf](http://www.uspto.gov/aia_implementation/pur-2011nov07-university_of_ca.pdf); Comments of Tony Tether, *supra* note 183, at 3; Comments of Various Higher Educ. Ass’n, *supra* note 194, at 2.

<sup>246</sup> Comments of Wis. Alumni Research Found., *supra* note 195, at 3; *see also* Comments of Various Higher Educ. Ass’n, *supra* note 194, at 1 (arguing that prior user rights reduce certainty of patent rights, which impacts the ability of universities to license patents).

<sup>247</sup> See Comments from Google and Verizon, *supra* 173, at 9-10 (noting that due to circumstances in the high technology area, choosing trade secret protection over patent protection may make more economic sense); Comments from Coalition for Patent Fairness, *supra* note 47, at 2 (arguing that not every business has the resources to patent every development); Comments of Greentech, *supra* note 47, at 1-2 (explaining that because many innovations in this area tend to be manufacturing processes, reliance on trade secrets over patents is an important strategic tool).

<sup>248</sup> See, e.g., Comments of the Computer & Commc’ns. Ind. Ass’n, *supra* note 185, at 3-4 (noting the substantial investment required to prepare and file patent applications, and the economic consequences of pursuing an ideal of public disclosure over other forms of protection).



provides a simpler means of protection and policing of a new technology.<sup>249</sup> By forgoing patent protection in favor of a trade secret, these entities can more efficiently allocate scarce resources to growth of other parts of the enterprise.<sup>250</sup>

Other comments noted that in certain industries, innovation tends to be incremental rather than pioneering, such as in the electronics and communications areas.<sup>251</sup> These comments pointed out that in such cases, the more economically rational and pro-competitive solution may be to protect advances as trade secrets, rather than through patent protection.<sup>252</sup> Moreover, forcing such minor advances into the patent system could, as observed by some comments, create a host of other problems, such as taxing USPTO resources and flooding the patent system with patents of dubious quality.<sup>253</sup>

As to the relationship between patents and trade secrets, the Supreme Court in *Kewanee Oil v. Bicorn Corp.*<sup>254</sup> recognized that trade secrets and patents can legally co-exist and that both trade secrets and patents have value. Additionally, in *Kewanee*, the Supreme Court recognized that trade secrets will not impede scientific progress (the goal of Article I, Section 8, Clause 8) because the ideas protected by trade secrets will likely be discovered by others in a similar time frame, stating that “[n]or does society face much risk that scientific or technological progress will be impeded by the rare inventor with a patentable invention who chooses trade secret protection over patent protection [...] [I]f a particular person had not made a discovery others would have, and in probably a relatively short period of time.”<sup>255</sup> In *Kewanee*, the Supreme Court also noted that trade secrets can be put into public use and thereby disclosed to those who can independently discover the idea.<sup>256</sup>

A related issue is the consequence that, by filing a patent application, the technology is disclosed to competitors in other countries where the innovator may not, for lack of resources, have sought patent protection, or where patents are difficult to enforce.<sup>257</sup> Several comments pointed out that this can have

---

<sup>249</sup> *Id.* at 1-2; *see also* Comments of Space Exploration Techs. Corp., *supra* note 47, at 2 (noting difficulties in policing enforcement in foreign jurisdictions).

<sup>250</sup> *See* Comments from Coalition for Patent Fairness, *supra* note 47, at 2 (suggesting that the choice to file patent applications comes at a cost of decreased funding for basic research). Cost savings from choosing trade secret over patent protection can also contribute to a company’s competitiveness in the field. *See* Comments of Space Exploration Techs. Corp., *supra* note 47, at 3-4.

<sup>251</sup> *See* Comments from Google and Verizon, *supra* 173, at 2, 3, 9 (noting the rapid pace and incremental nature of innovation in the high technology sector); Comments of the Computer & Commc’ns. Ind. Ass’n, *supra* note 185, at 3-4 (arguing that the faster and more continuous the pace of innovation, the more pressure would be placed on a company to file for patent protection, in the absence of prior user rights).

<sup>252</sup> *See, e.g.*, Comments from Google and Verizon, *supra* 173, at 1-2.

<sup>253</sup> Comments of the Computer & Commc’ns. Ind. Ass’n, *supra* note 185, at 4-5.

<sup>254</sup> 416 U.S. 470, 493 (1974).

<sup>255</sup> *See id.* at 491.

<sup>256</sup> *Id.*

<sup>257</sup> *See* Comments of Greentech, *supra* note 47, at 2, *and* Comments of Space Exploration Techs. Corp., *supra* note 47, at 2.

drastic effects on American businesses and jobs. A representative from a small United States company commented that the company's use of trade secret protection enables it to provide services at a price level that its Chinese competitors admitted they cannot match.<sup>258</sup> Several representatives of "green" technology companies based in the United States noted that disclosure of new technologies via a patent application would allow foreign competitors to copy the innovation, using cheaper labor and with the assistance of foreign government subsidies, to undercut their businesses, at the expense of "creating much-needed jobs for American workers."<sup>259</sup>

Thus, the USPTO finds that:

**Finding 8: Trade secret protection is of considerable value to United States businesses and the United States economy, and as such, there are compelling economic and policy justifications for providing a prior user rights defense to patent infringement.**

On the basis of the above analysis and findings, the USPTO recommends as follows:

**Recommendation 4: United States patent law should provide for a prior user rights defense as an appropriate balance between trade secret protection and patent protection, which legally co-exist to provide competitive advantages for United States businesses.**

#### **D. Analysis of Whether a First-to-File Patent System Creates a Need for Prior User Rights**

One of the most fundamental changes under the AIA is in the way that entitlement to a patent is determined. The United States has historically awarded a patent to the first person to have invented the subject matter, commonly referred to as the "first-to-invent" standard. According to this approach, if two inventors file patent applications for the same invention, the patent is awarded to the first person to have conceived of the invention and to have reduced it to practice.<sup>260</sup>

Since 1998, the United States has been the only country in the world to use the first-to-invent standard.<sup>261</sup> Every other patent-granting country awards a patent to the first inventor to have filed an application for the subject matter. This approach, known as "first-to-file," relies on application filing

---

<sup>258</sup> Comments of Space Exploration Techs. Corp., *supra* note 47, at 3-4.

<sup>259</sup> Comments of Greentech, *supra* note 47, at 1-2.

<sup>260</sup> 35 U.S.C. § 102(g) (2006).

<sup>261</sup> The Philippines, the last country other than the United States to have a first-to-invent system, changed its law in 1998.

dates, rather than dates of invention and reduction to practice, to determine priority as between competing applicants. Hence, the entity who files first has the right to the patent.<sup>262</sup> Section 3 of the AIA transitions the United States to a first-inventor-to-file patent system from a first-to-invent system and establishes derivation proceedings in place of interference proceedings.

In transitioning from a first-to-invent to first-inventor-to-file system, the AIA makes a number of ancillary changes to United States patent law, either as a direct result of, or consequential to, implementation of the first-inventor-to-file standard. One significant amendment in this respect is the expansion of the prior user rights defense set forth in the newly enacted section 273 of title 35.<sup>263</sup>

The switch from first-to-invent to first-inventor-to-file is cited in the legislative history of the AIA as the main impetus behind the changes to section 273.<sup>264</sup> One of the direct results of adopting a first-inventor-to-file regime is the elimination of section 102(g)(2) of the current law.<sup>265</sup> Section 102(g)(2) is the basis for the first-to-invent principle in current law and provides that an applicant is entitled to a patent unless “before the applicant’s invention thereof, the invention was made . . . by another who had not abandoned, suppressed, or concealed it.”<sup>266</sup> Under this provision, a prior user who did not abandon, suppress, or conceal the invention can invalidate the later patent of another and thereby escape liability for infringement.<sup>267</sup>

---

<sup>262</sup> See H.R. REP. NO. 112-98, at 40.

<sup>263</sup> 157 Cong. Rec. S5402, S5429-30 (Sept. 8, 2011) (Statement of Sen. Kyl) (noting that the expansion of prior user rights was “perhaps the most important” consequential change in view of the transition to first-inventor-to-file; see also 157 Cong. Rec. E1219, E1219 (June 28, 2011) (Extended Remarks of Rep. Smith) (“One key part of the transition [...] is the necessary inclusion of prior user rights under the new first-inventor-to-file system. The inclusion of prior user rights is essential to ensure that those who have invented and used a technology but choose not to disclose that technology [...] are provided a defense against someone who later patents the technology.”).

<sup>264</sup> *Supra* note 263; see also 157 Cong. Rec. H4480, H4483 (June 23, 2011) (Statement of Rep. Smith) (“Prior-user rights are important as part of our change to a first-to-file system.”); and *id.* at H4492 (Statement of Rep. Lofgren) (“[Y]ou cannot have first-to-file without robust prior-user rights.”).

<sup>265</sup> Pub. L. No. 112-29, § 3, 125 Stat 284, 285-87 (2011) (replacing existing Section 102, including Section 102(g), with new provisions for determining novelty and non-obviousness based on filing dates instead of dates of “invention.”); see also 157 Cong. Rec. S5402, S5426 (Sept. 8, 2011) (Statement of Sen. Blunt) (noting the elimination of the “prior invention bar to patentability under section 102(g)(2)”).

<sup>266</sup> 35 U.S.C. § 102(g)(2).

<sup>267</sup> See, e.g., *Dunlop Holdings Ltd. v. Ram Golf Corp.*, 524 F.2d 33 (7th Cir. 1975). Although it is beyond the scope of this Report, it should be noted that there appears to be some ambiguity in the case law regarding the conditions under which a non-informing prior use by another may create patent-invalidating prior art under the existing statute. Compare *W.L. Gore & Assocs., Inc. v. Garlock, Inc.*, 721 F.2d 1540 (Fed. Cir. 1983) (non-informing use by a third party held not to invalidate the patent to another). The commentary on the subject is illustrative of the ambiguity. Compare *Griswold & Ubel*, *supra* note 9, at 572, n.20 (arguing that *Gore* was decided on grounds other than § 102(g)); and *Jorda*, *supra* note 15, at 28 (arguing that *Gore* only stands for the proposition that third party trade secrets are not invalidating prior art, which is entirely different from “a holding that the trade secret holder is an infringer vis-à-vis the patentee”); with Wendy H. Schacht & John R. Thomas, *Patent Reform in the 112th Congress: Innovation Issues*, Congressional Research Service Report for Congress, at 12 (June 30, 2011) (arguing that under the “settled patent law principle” announced in *Gore*, “[i]f an earlier inventor made secret commercial use of an

In a first-inventor-to-file regime, earlier invention is not a defense. As a result, the patent may be given to the first inventor to file an application for the invention. This raises the possibility, in the absence of a defense mechanism analogous to section 102(g)(2), that a party that earlier invented and commercially used the subject matter without disclosing it could be liable for infringement as against another party that later obtained a patent on it.

### **Analysis and Findings**

Because the intersection of the first-inventor-to-file standard and prior user rights has been the subject of over two decades of legislative and academic debate in the United States, there is a wealth of commentary on the issue.<sup>268</sup> Most recently, in response to the Federal Register Notice requesting comments on the operation of prior user rights, the USPTO received twenty-nine comments, including both written submissions and oral testimony, which addressed the interaction between the first-inventor-to-file standard and prior user rights. All of these comments expressed views about including prior user rights in a first-inventor-to-file system, some went even further and explicitly noted that prior user rights were either “essential,” “critical,” or otherwise necessary in such a system to balance various interests. Seven of the comments received, including from representatives of technology transfer offices or other entities involved in commercialization of upstream research, expressed negative views about prior user rights as a general matter, without specifying linkage to first-inventor-to-file. Some of the comments merely expressed skepticism or concern; others argued that prior user rights should not be permitted for a variety of reasons.

Despite the diversity of viewpoints expressed, the comments reveal a common analytical framework for considering the issue whether a first-inventor-to-file system creates a need for prior user rights. All of the responsive comments, like much of the extant literature on the subject, contain arguments either for or against prior user rights that can fairly be characterized as falling under one of the following headings: (i) fairness to the party who has expended effort and resources in using the later patented technology; and (ii) harmonization of patent systems.

#### **1. Balancing interests of the prior user and the patentee**

---

invention, and another person independently invented the same technology later and obtained patent protection, then the trade secret holder could face liability for patent infringement”).

<sup>268</sup>See *supra* note 20.

The reason most frequently cited in support of prior user rights in a first-inventor-to-file regime is ensuring “fairness” -- appropriately balancing the equitable interests of the prior user and the patentee.<sup>269</sup> As noted above, a first-inventor-to-file system creates the potential for inequity if an earlier inventor commercializes a new technology without disclosing it, but another later obtains a patent on it. In such a situation, the earlier inventor may be subject to liability for infringement, which could entail a substantial loss of investment, loss of jobs, and erosion of U.S manufacturing. A prior user rights defense addresses this issue by allowing the earlier inventor to continue using the invention without liability, subject to certain conditions, while the patentee still enjoys exclusive rights as against everyone except the prior user.<sup>270</sup>

“Fairness” has been a common theme in the history of United States patent law.<sup>271</sup> Prior user rights have been specifically provided in the United States in the past as a means to balance respective interests.<sup>272</sup> The prior use defense applicable only to business methods, for instance, was enacted to protect businesses against infringement claims for using processes thought to be unpatentable before the decision in *State Street*.<sup>273</sup> Moreover, since 1952, United States patent law has provided a prior invention defense by virtue of section 102(g)(2), the elimination of which under the AIA creates a need for a similar defense applicable in a first-inventor-to-file environment to ensure a continued and similar balancing of interests under the new law.<sup>274</sup>

This same notion of “fairness” also underlies the provision of prior user rights in other jurisdictions.<sup>275</sup> A number of comments received were from, or on behalf of, foreign practitioners having experience with, or knowledge of, prior user rights in their home countries, *e.g.*, Japan, Germany and Australia. Several of these comments highlight the same basic dilemma created by a first-inventor-to-file regime, *i.e.*, that of an earlier commercial user and a later patentee of the same subject matter, as the motivating factor behind the establishment of prior user rights in those countries.<sup>276</sup> One German

---

<sup>269</sup> See, *e.g.*, H.R. Rep. 112-98 at 87 (Letter from Secretary of Commerce Gary Locke to House Judiciary Committee Chairman Lamar Smith (May 31, 2011)) (providing a prior user rights defense is a “matter of fairness”); *see generally*, Kupferschmid, *supra* note 9 at 217, 229 (citing “fairness” as argument number one for and against prior user rights out a litany of arguments summarized in the article).

<sup>270</sup> Comments of Microsoft Corp., at 5.

<sup>271</sup> See Kyla Harriel, *Prior User Rights in a First-to-Invent Patent System: Why Not?*, 36 IDEA 543, 553-55 (1996) (noting the relationship between prior user rights and notions of “economic justice” that underlie U.S. law as it relates to rewarding innovation and creativity).

<sup>272</sup> See Kupferschmid, *supra* note 9, at 217, 229.

<sup>273</sup> See *supra* note 20.

<sup>274</sup> See *id.* and Comments of Microsoft Corp., *supra* note 43, at 6.

<sup>275</sup> VAN EECHE *supra* note 125, at 23-24 (noting that prior user rights “are almost unanimously recognized in the [European Union] as being just and desirable on the grounds of both fairness and efficiency”).

<sup>276</sup> See, *e.g.*, Comments from Freischem, *supra* note 39, at 3 (Germany); Comments of Telstra Corp., *supra* note 37, at 3(Australia); and Comments from Dr. Shoichi Okuyama, President, Japan Patent Attorneys Ass’n, to Mary Critharis et al., Senior Patent Counsel, USPTO, Office of Policy and External Affairs, Submission to the Request for

practitioner even noted that first-inventor-to-file is the “source” of prior user rights and that the potential inequity it causes makes prior user rights “essential” in such a system.<sup>277</sup>

Unfortunately, there is very little empirical data on the frequency of use of the prior user rights upon which to base a conclusion that providing them in a first-inventor-to-file regime is quantitatively essential. Many of the comments and the few studies on the subject note that there have been only a relative handful of litigation outcomes involving the prior user rights defense, either in the United States or abroad.<sup>278</sup> Some of the comments, however, explain that litigation outcomes only tell part of the story. The prior user rights defense frequently leads to pre-litigation settlements between the prior user and the patentee that are not – and in fact, could not be – revealed in empirical studies given the confidential nature of the settlements, or because the lack of pre-trial discovery in some jurisdictions prevents uncovering prior uses, limiting application of the defense.<sup>279</sup>

Thus, the USPTO finds that:

**Finding 9: Providing limited prior user rights in a first-inventor-to-file system addresses the inherent inequity such a system creates between an earlier commercial user of the subject matter and a later patentee. A prior user rights defense is pro-manufacturing and pro-jobs, as it rewards businesses that put new technology promptly into commercial use, and provides protection for early commercial use when challenged by the later filing of patent applications by other entities.**

---

Comments on the Study of Prior User Rights 1 (Nov. 7, 2011) [hereinafter “Comments from Japan Patent Attorneys Ass’n”] [http://www.uspto.gov/aia\\_implementation/pur-2011nov08-jpaa.pdf](http://www.uspto.gov/aia_implementation/pur-2011nov08-jpaa.pdf).

<sup>277</sup> Comments from Freischem, *supra* note 39, at 3.

<sup>278</sup> See Lise Osterborg, *Towards a Harmonized Prior User Right Within a Common Market System*, 12 INT’L REV. INDUS. PROP. & COPYRIGHT 447, 456-59 (1981) (noting the dearth of reported prior user rights cases in France, England, Italy and the Netherlands); John Neukom, *A Prior Use Right for the Community Patent Convention*, 12 EUR. INTELL. PROP. REV. 165, 166 (1990) (few reported cases in West Germany); Comments of Microsoft Corp., *supra* note 43, at 4 (since 1977, there appear to be only 5 reported cases in the U.K.); and Comments of FICPI, *supra* note 2 (few reported cases in Europe and Brazil); *but see* Maeda, *supra* note 133, at 52 (reporting survey results suggesting frequent reliance on prior user rights by Japanese companies to avoid infringement litigation). A recent study on usage of the Section 102(g)(2) prior inventor defense in the U.S. suggests, by analogy, that prior user rights may be asserted with some frequency under the new regime provided in the AIA. Comments from Lex Machina, Inc., to the USPTO, U.S. Prior User Rights / Inventorship Study 1 (Nov. 7, 2011), [http://www.uspto.gov/aia\\_implementation/pur-2011nov08-lex\\_machina.pdf](http://www.uspto.gov/aia_implementation/pur-2011nov08-lex_machina.pdf) (noting surprisingly high usage of Section 102(g)(2) in reported cases).

<sup>279</sup> Comments from Freischem, *supra* note 39, at 1-2; Comments of FICPI, *supra* note 40, at 2; Comments from Comments of Microsoft Corp., *supra* note 43, at 4 (referencing findings of the European Union report cited *supra*, note 275, including that settlement prior to litigation helped explain the low rate of reported usage of prior user rights in Europe); *see also* Comments from Coalition for Patent Fairness, at 4-5 (suggesting that lack of discovery in foreign jurisdictions limits application of the defense).

## 2. Harmonization of Patent Laws

Several of the comments pointed out that the lack of a prior user rights regime in a first-inventor-to-file system in the United States would put United States businesses at a disadvantage in comparison with its competitive trading partners, such as Europe, Canada, Japan, Korea, and Australia. Because these countries have prior use protections in their patent laws, this disharmony could disadvantage United States enterprises by making them liable for infringement in the United States as against a foreign-based United States patent holder, but unable to assert a foreign patent against a foreign entity in a jurisdiction that provides prior user rights.<sup>280</sup> Some comments further stated that this imbalance could lead to strategic decisions to locate businesses or components thereof, and the jobs that go along with them, outside the United States to prevent disruptions to operations or interference with the use of assets.<sup>281</sup>

Previous studies suggest that the magnitude of the potential imbalance is significant. One comment referenced a 1994 study that found that foreign countries representing about 85% of GDP outside the United States provided prior user rights.<sup>282</sup> Another study pointed out that United States interests were particularly at risk given the high percentage of United States patents awarded to foreign inventors.<sup>283</sup>

Thus, the USPTO finds that:

**Finding 10: Because the availability of a prior user rights defense to patent infringement is a fundamental aspect of many patent regimes throughout the world, there is a strong preference that United States businesses be afforded the same advantages in terms of prior use protections in the United States that their competitors enjoy abroad.**

On the basis of the above analysis and findings, the USPTO recommends as follows:

---

<sup>280</sup> Kupferschmid, *supra* note 9, at 221.

<sup>281</sup> Testimony of Gary Griswold, *supra* note 214, at 12-13; *see also*, Griswold & Ubel, *supra* note 9, at 577 (suggesting that lack of prior user rights in the United States may affect investment in U.S.-based assets); *and* Comments of Microsoft Corp., *supra* note 270, at 5 (noting that prior user rights permit the prior inventor/user to continue existing activities).

<sup>282</sup> Testimony of Gary Griswold, *supra* note 281.

<sup>283</sup> *See* Griswold & Ubel, *supra* note 9, at 568 (asserting that about 45% of U.S. patents granted in 1993 were foreign-owned). In terms of more recent available data, in Fiscal Year 2011, the USPTO issued 124,252 patents to residents of foreign countries out of a total of 244,430 patents issued in the same time period, suggesting that a little over 50% of patents issued in FY 2011 are foreign owned. *See* U.S. Patent and Trademark Office Performance and Accountability Report Fiscal Year 2011, at 163, 165, and 168 (2011), *available at* <http://www.uspto.gov/about/stratplan/ar/2011/USPTOFY2011PAR.pdf>.

**Recommendation 5: United States patent law should provide for a prior user rights defense to patent infringement in order to address a systemic inequity inherent in a first-inventor-to-file system and to ensure United States businesses are (1) able to protect their investments in the event of a later issued patent, and (2) placed on similar footing as competitors in other jurisdictions.**

#### **IV. CONCLUSION**

The availability of a prior use defense for alleged patent infringement is a fundamental aspect of many patent regimes throughout the industrialized world and the characteristics of the prior use defense in these countries are fairly consistent from country-to-country. The policy reasons for adopting a prior use defense are also fairly universal – prior user rights remedy the unfairness in holding a prior commercial user liable for patent infringement.

The recently enacted AIA incorporates a carefully crafted prior use defense consistent with the prior use defense found in many industrialized countries of the world, with certain unique features so that the only parties who can prove commercial use at least one year prior to the filing date of the patent application can obtain the defense. The scope of the defense is limited in the type activities that may be continued in relation to the original prior use activities so that the patentee's rights are not unjustly impinged. The prior user rights defense as set forth in the AIA is narrowly tailored and not expected to be asserted frequently in patent litigation. There is no substantial evidence that prior user rights will negatively impact innovation, start-up enterprises, venture capital, small businesses, universities or individual inventors. The USPTO should, however, reevaluate the economic impacts of prior user rights as part of its 2015 report to Congress on the implementation of the AIA when better evidence as to these impacts might be available.

A prior use defense to patent infringement, and specifically the one set forth in the AIA, is neither unconstitutional nor unlawful, as the defense is consistent with the Constitution and Supreme Court precedent recognizing that trade secret law and patent law can and do legally co-exist in the United States as they have for hundreds of years. Trade secret protection is of considerable value to United States businesses and the United States economy, and as such, there are compelling economic and policy justifications for providing a prior user rights defense to patent infringement. Providing suitably limited prior user rights in a first-inventor-to-file system is an appropriate response to an inherent inequity such a system creates as between an earlier commercial user of the subject matter and a later patentee. There is a strong preference that United States businesses be afforded the same advantages in terms of prior use protections in the United States that their competitors enjoy abroad.



***Appendix A: Prior Use Defense in the American Inventors Protection Act of 1999***<sup>284</sup>

**Defense to infringement based on earlier inventor.**

- (a) DEFINITIONS— For purposes of this section—
- (1) the terms “commercially used” and “commercial use” mean use of a method in the United States, so long as such use is in connection with an internal commercial use or an actual arm’s-length sale or other arm’s-length commercial transfer of a useful end result, whether or not the subject matter at issue is accessible to or otherwise known to the public, except that the subject matter for which commercial marketing or use is subject to a premarketing regulatory review period during which the safety or efficacy of the subject matter is established, including any period specified in section 156(g), shall be deemed “commercially used” and in “commercial use” during such regulatory review period;
- (2) in the case of activities performed by a nonprofit research laboratory, or nonprofit entity such as a university, research center, or hospital, a use for which the public is the intended beneficiary shall be considered to be a use described in paragraph (1), except that the use—
- (A) may be asserted as a defense under this section only for continued use by and in the laboratory or nonprofit entity; and
- (B) may not be asserted as a defense with respect to any subsequent commercialization or use outside such laboratory or nonprofit entity;
- (3) the term “method” means a method of doing or conducting business; and
- (4) the “effective filing date” of a patent is the earlier of the actual filing date of the application for the patent or the filing date of any earlier United States, foreign, or international application to which the subject matter at issue is entitled under section 119, 120, or 365 of this title.
- (b) DEFENSE TO INFRINGEMENT—
- (1) IN GENERAL— It shall be a defense to an action for infringement under section 271 of this title with respect to any subject matter that would otherwise infringe one or more claims for a method in the patent being asserted against a person, if such person had, acting in good faith, actually reduced the subject matter to practice at least 1 year before the effective filing date of such patent, and commercially used the subject matter before the effective filing date of such patent.

[...]

---

<sup>284</sup> American Inventor Protection Act of 1999, 35 U.S.C. § 273 (1999) (repealed and replaced by the Leahy-Smith America Invents Act, Pub. L. No. 112-29, § 5, 125 Stat. 284, 297-99 (2011)).

- (2) **LIMITATIONS AND QUALIFICATIONS OF DEFENSE**— The defense to infringement under this section is subject to the following:
- (A) **PATENT**— A person may not assert the defense under this section unless the invention for which the defense is asserted is for a method.
  - (B) **DERIVATION**— A person may not assert the defense under this section if the subject matter on which the defense is based was derived from the patentee or persons in privity with the patentee.
  - (C) **NOT A GENERAL LICENSE**— The defense asserted by a person under this section is not a general license under all claims of the patent at issue, but extends only to the specific subject matter claimed in the patent with respect to which the person can assert a defense under this chapter, except that the defense shall also extend to variations in the quantity or volume of use of the claimed subject matter, and to improvements in the claimed subject matter that do not infringe additional specifically claimed subject matter of the patent.
- [...]
- (6) **PERSONAL DEFENSE**— The defense under this section may be asserted only by the person who performed the acts necessary to establish the defense and, except for any transfer to the patent owner, the right to assert the defense shall not be licensed or assigned or transferred to another person except as an ancillary and subordinate part of a good faith assignment or transfer for other reasons of the entire enterprise or line of business to which the defense relates.

**Appendix B: Prior Use Defense in the *Leahy-Smith America Invents Act*<sup>285</sup>**

**Defense to infringement based on prior commercial use**

- (a) IN GENERAL—A person shall be entitled to a defense under section 282(b) with respect to subject matter consisting of a process, or consisting of a machine, manufacture, or composition of matter used in a manufacturing or other commercial process, that would otherwise infringe a claimed invention being asserted against the person if—
  - (1) such person, acting in good faith, commercially used the subject matter in the United States, either in connection with an internal commercial use or an actual arm’s length sale or other arm’s length commercial transfer of a useful end result of such commercial use; and
  - (2) such commercial use occurred at least 1 year before the earlier of either—
    - (A) the effective filing date of the claimed invention; or
    - (B) the date on which the claimed invention was disclosed to the public in a manner that qualified for the exception from prior art under section 102(b).

[...]

(e) LIMITATIONS AND EXCEPTIONS—

(1) PERSONAL DEFENSE—

- (A) IN GENERAL—A defense under this section may be asserted only by the person who performed or directed the performance of the commercial use described in subsection (a), or by an entity that controls, is controlled by, or is under common control with such person.
- (B) TRANSFER OF RIGHT—Except for any transfer to the patent owner, the right to assert a defense under this section shall not be licensed or assigned or transferred to another person except as an ancillary and subordinate part of a good-faith assignment or transfer for other reasons of the entire enterprise or line of business to which the defense relates.
- (C) RESTRICTION ON SITES—A defense under this section, when acquired by a person as part of an assignment or transfer described in subparagraph (B), may only be asserted for uses at sites where the subject matter that would otherwise infringe a claimed invention is in use before the later of the effective filing date of the claimed invention or the date of the assignment or transfer of such enterprise or line of business.

---

<sup>285</sup> Leahy-Smith America Invents Act, Pub. L. No. 112-29, § 5, 125 Stat. 284, 297-99 (2011).

- (2) DERIVATION—A person may not assert a defense under this section if the subject matter on which the defense is based was derived from the patentee or persons in privity with the patentee.
- (3) NOT A GENERAL LICENSE—The defense asserted by a person under this section is not a general license under all claims of the patent at issue, but extends only to the specific subject matter for which it has been established that a commercial use that qualifies under this section occurred, except that the defense shall also extend to variations in the quantity or volume of use of the claimed subject matter, and to improvements in the claimed subject matter that do not infringe additional specifically claimed subject matter of the patent.

[...]

- (5) UNIVERSITY EXCEPTION—
  - (A) IN GENERAL—A person commercially using subject matter to which subsection (a) applies may not assert a defense under this section if the claimed invention with respect to which the defense is asserted was, at the time the invention was made, owned or subject to an obligation of assignment to either an institution of higher education (as defined in section 101(a) of the Higher Education Act of 1965 (20 U.S.C. 1001(a)), or a technology transfer organization whose primary purpose is to facilitate the commercialization of technologies developed by one or more such institutions of higher education.
  - (B) EXCEPTION—Subparagraph (A) shall not apply if any of the activities required to reduce to practice the subject matter of the claimed invention could not have been undertaken using funds provided by the Federal Government.

## Appendix C: List of Parties Providing Testimony and/or Comments<sup>286</sup>

### **Individuals Providing Testimony**

Gary Griswold (on his own behalf)

Alan Kasper (AIPLA)

Thomas Kurkowski (on his own behalf)

Dan Lang (Cisco)

MaCharri Vorndran-Jones (ABA-IP Group)

### **Intellectual Property Organizations**

America Bar Association – IP Section

American Intellectual Property Association (AIPLA)

Coalition for Patent Fairness

Computer & Communications Industry Association (CCIA)

Institute of Patent and Trade Mark Attorneys of Australia

International Federation of Intellectual Property Attorneys (FICPI)

Japan Intellectual Property Association Innovation Alliance

Japan Patent Attorneys Association

New Zealand Institute of Patent Attorneys

### **Academic and Research Institutions**

Wisconsin Alumni Research Foundation

Berkeley Center for Law and Technology and Greentech Industries<sup>287</sup>

Regents of University of California Board

Higher Education Associations<sup>288</sup>

---

<sup>286</sup> See Notice of Public Hearing and Request for Comments on the Study of Prior User Rights, 76 Fed. Reg. 62,388 (Oct. 7, 2011).

<sup>287</sup> Greentech Industries consists of: Soraa, Inc.; Sakti3, Inc.; EchoFirst, Inc.; Solaria Corp.; Stion Corp.; Topanga Techs., Inc.

**Companies**

Belz Consulting

Cisco

Google and Verizon (Joint Comments)

Hospira, Inc.

Lex Machina

Microsoft Corp.

Space Exploration Technologies Corp.

Telstra Corporation

**Individuals**

Stephan Freischem

Asamichi Kato

Thomas E. Kelley

Thomas Kowalski

Paul Morgan

Tony Tether

Neil Thomas

---

<sup>288</sup> Higher Education Associations consists of: Association of American Universities, American Council on Education, Association of American Medical Colleges, Association of Public and Land-grant Universities, Association of University Technology Managers, Council on Governmental Relations.

### Appendix D: Comparison Chart of Studied Countries

	Prior Use Activities	Definition of Prior User	Scope of Prior User Activities	Transfer
<b>Australia</b>	Exploitation or definitive steps toward exploitation	Acquisition ok Requires good faith	Scope may not be extended from prior use	Freely assignable
<b>Brazil</b>	Exploitation of the patented subject matter	Acquisition ok Requires good faith	In same manner under same conditions	Only together with business, or part of business to which it belongs
<b>Canada</b>	Purchase, construction or acquisition of a later patented invention	Acquisition ok Requires good faith	Scope may not be extended from prior use	Encompasses purchase, construction or acquisition – transfer unclear
<b>China</b>	Use/manufacture or making necessary preparations for same	Acquisition ok Requires good faith	Scope may not be extended from prior use	Only together with business
<b>Denmark</b>	Exploiting the invention commercially or substantial preparations	Acquisition ok Requires good faith	Prior User Right exploitation must retain its general character	Only together with business
<b>France</b>	Possession of the invention (preparations of an industrial/productive nature)	Acquisition ok Requires good faith	Any equivalents of the patented invention	Only together with business, or part of business to which it belongs
<b>Germany</b>	Use or necessary arrangements to do the same	no	Limited to the particular needs of the business	Only together with business
<b>Japan</b>	Working the invention or preparing for the same	Acquisition ok Requires good faith	Extent of invention on purpose of such business	Only together with business, or with patent owner's consent or by succession
<b>Republic of Korea</b>	Working the invention or preparing for the same	Acquisition ok Requires good faith	Scope of the objective of the invention or the related business	Only together with business or with patent owner's consent or by succession
<b>Mexico</b>	Use or necessary preparations for the same	Acquisition ok No good faith requirement in law	Scope may not be extended from prior use	Prior user rights are not transferable
<b>Russian Federation</b>	Use or necessary preparations for the same	Requires conception; requires good faith	Scope may not be extended from prior use	Only together with business, or part of business to which it belongs
<b>United Kingdom</b>	Acts that would constitute infringement or effective and serious preparation	Acquisition ok Requires good faith	Does not affect the essence of the invention	Only together with business, or part of business to which it belongs
<b>United States</b>	One full year of commercial use	Requires reduction to practice Requires good faith	Scope that might otherwise be considered infringing use	Only together with the entire enterprise or line of business



The United States Patent and Trademark Office