

## E05B

### LOCKS; ACCESSORIES THEREFOR; HANDCUFFS

#### Definition statement

*This place covers:*

Locks for swingable, slidable, or otherwise movable wings, e.g. doors or windows, for restricting access, which are usually, but not necessarily always, unlocked by means of a key or equivalent means, e.g. combination means, electrical means, etc. It also covers handles or knobs for wings, including handles for wings which do not operate the locking mechanism. It additionally covers latching or locking means for other movable structures such as drawers, lids of chests, vehicle doors, vehicle lids for luggage or engine compartments, to which the locking means covered by this subclass may be applied. It further covers devices for locking clothing, locks specially adapted for bicycles, locks for locking portable objects against unauthorised removal and handcuffs.

#### Relationships with other classification places

- Bolts or fastening devices for wings, specially for doors or windows: [E05C](#);
- Hinges or other suspension devices for door, windows or wings: [E05D](#);
- Devices for moving wings into open or closed positions: [E05F](#);
- Safes or strong-rooms: [E05G](#);
- Door, windows, shutters, roller blinds, gate: [E06B](#)
- Individual entry or exist registers: [G07C 9/00](#)

#### References

##### Limiting references

*This place does not cover:*

Buckles; Similar fasteners for interconnecting straps or the like	<a href="#">A44B 11/00</a>
Devices for fastening or securing constructional elements or machine parts together	<a href="#">F16B</a>
Electronic locks	<a href="#">G07C 9/00</a>

##### Application-oriented references

*Examples of places where the subject matter of this place is covered when specially adapted, used for a particular purpose, or incorporated in a larger system:*

Door latches for dish washers	<a href="#">A47L 15/4259</a>
Locking devices for vehicle seats, e.g. for back rests or for locking a seat relative to the floor	<a href="#">B60N 2/00</a>
Locking devices for container closures	<a href="#">B65D 55/02</a>
Locking or fastening means for lids or covers of refuse receptacles	<a href="#">B65F 1/1615</a>
Locks for washing machines	<a href="#">D06F 39/14</a>
Locking of doors, covers, guards acting in conjunction with the control or operation of a machine	<a href="#">F16P 3/08</a>
Latches for doors specially adapted for stoves	<a href="#">F24C 15/022</a>

## Glossary of terms

In this place, the following terms or expressions are used with the meaning indicated:

Bolt	means a sliding, pivoted, or otherwise movable member such as is normally carried by a door to hold it shut by engagement with a keeper on the frame. It may be operated by hand directly or through mechanism or by a key; it may be a latch (see below);
Frame	means any member to which a wing may be held by a fastening device. It does not include a framework forming part of the wing, but it may be another wing.
Hasp	means a member hinged to the frame or wing so that it can be moved towards the face of the wing or frame and secured thereto, e.g. by a turn-button, by a padlock and staple.
Latch	means a bolt arranged to be moved to the releasing position against the force of a spring, or some other returning force, when a wing meets the frame on closing, so that it does not have to be operated by hand to secure the wing, but only to open it.
Lock	means primarily a device for releasing or securing any member, which requires a key or a permutation mechanism for release. In groups <a href="#">E05B 1/00- E05B 9/00</a> , <a href="#">E05B 13/00- E05B 17/00</a> , <a href="#">E05B 39/00- E05B 47/00</a> , <a href="#">E05B 51/00</a> , <a href="#">E05B 53/00</a> , <a href="#">E05B 63/00</a> and <a href="#">E05B 65/00</a> however, the term "lock" may include other fastening devices.
Wing	is a general term for swingable, slidable, or otherwise movable doors or windows. This term also includes other movable structures such as drawers, lids of chests, car boots, or car bonnets, to which the operating, mounting, latching, or locking means covered by this class may be applied.

## E05B 1/00

**Knobs or handles for wings; Knobs, handles, or press buttons for locks or latches on wings ([E05B 5/00](#), [E05B 7/00](#) take precedence)**

### Definition statement

*This place covers:*

Knobs, handles or push-buttons for wings. The handles can be movable or non-movable

### References

#### Limiting references

*This place does not cover:*

Handles completely let into the surface of the wing	<a href="#">E05B 5/00</a>
Handles pivoted about an axis parallel to the wing	<a href="#">E05B 7/00</a>

#### Application-oriented references

*Examples of places where the subject matter of this place is covered when specially adapted, used for a particular purpose, or incorporated in a larger system:*

Handles for vehicles	<a href="#">E05B 85/10</a> - <a href="#">E05B 85/18</a>
----------------------	---

Knobs or handles for furniture	<a href="#">A47B 95/02</a>
Straps provided with handles for bundling articles	<a href="#">B65D 63/18</a>
Controlling members for hand actuation, e.g. handles	<a href="#">G05G 1/00</a>

### **Informative references**

Attention is drawn to the following places, which may be of interest for search:

Handles for suitcases or travelling bags	<a href="#">A45C 13/26</a>
Handles for carrying purposes	<a href="#">A45F 5/10</a>
Methods or apparatus for disinfecting materials	<a href="#">A61L 2/00</a>
Handles for hand implements, e.g. for tools	<a href="#">B21G 1/00</a>
Handgrips or straps for passengers in vehicles	<a href="#">B60N 3/02</a>
Handles for containers	<a href="#">B65D 25/28</a>
Handles for sacks or bags	<a href="#">B65D 33/06</a>
Details of refrigerator doors	<a href="#">F25D 23/028</a>

## **E05B 3/00**

**Fastening {knobs or} handles to lock or latch parts {(E05B 79/06 takes precedence)}**

### **Definition statement**

*This place covers:*

Fastening the knob or handle to lock or latch parts, in particular to the lock spindle, as well as fastening the spindle to the lock follower.

### **References**

#### **Limiting references**

*This place does not cover:*

Mounting handles to a vehicle wing	<a href="#">E05B 79/06</a>
------------------------------------	----------------------------

### **Informative references**

Attention is drawn to the following places, which may be of interest for search:

Mounting of handles which do not operate the bolt	<a href="#">E05B 1/0015</a>
Fastening locks or fasteners or parts thereof to the wing	<a href="#">E05B 9/08</a>

## E05B 5/00

Handles completely let into the surface of the wing {(E05B 85/10 takes precedence)}

### Definition statement

*This place covers:*

Handles which are flush when mounted to a wing and pop-out handles.

### References

#### Limiting references

*This place does not cover:*

Handles for vehicles	<a href="#">E05B 85/10</a> - <a href="#">E05B 85/18</a>
----------------------	---

#### Informative references

*Attention is drawn to the following places, which may be of interest for search:*

Handles combined with bolt movement	<a href="#">E05C 1/00</a> , <a href="#">E05C 3/00</a>
-------------------------------------	---

## E05B 7/00

Handles pivoted about an axis parallel to the wing ([E05B 5/00](#), {[E05B 85/14](#)} take precedence; {combined with bolt movement [E05C 1/00](#), [E05C 3/00](#)})

### Definition statement

*This place covers:*

Handles pivoted about an axis parallel to the wing

### References

#### Limiting references

*This place does not cover:*

Handles for vehicles	<a href="#">E05B 85/10</a> - <a href="#">E05B 85/18</a>
----------------------	---

#### Informative references

*Attention is drawn to the following places, which may be of interest for search:*

Handles combined with bolt movement	<a href="#">E05C 1/00</a> , <a href="#">E05C 3/00</a>
-------------------------------------	---

## E05B 9/00

**Lock casings or latch-mechanism casings {; Fastening locks or fasteners or parts thereof to the wing} (padlock casings [E05B 67/02](#); for vehicles [E05B 79/04](#), [E05B 85/02](#))**

### Definition statement

*This place covers:*

Lock or latch mechanism casings of latch bolt locks, of dead bolt locks and of cylinder locks;

Face plates;

Fastening of locks or parts thereof to the wing;

Coupling devices for the two halves of a double cylinder lock.

This group has the following structure:

Faceplates or front plates	<a href="#">E05B 9/002</a>
Casing of latch bolt or dead bolt locks	<a href="#">E05B 9/02</a>
Casing of cylinder locks	<a href="#">E05B 9/04</a>
Fastening locks or fasteners or parts thereof, e.g. the casings of latch bolt or dead bolt locks to the wing	<a href="#">E05B 9/08</a>
Fastening of lock cylinders to the wing	<a href="#">E05B 9/084</a>
Fastening plugs or cores to an outer stator	<a href="#">E05B 9/086</a>
Coupling devices for the two halves of double cylinder locks	<a href="#">E05B 9/10</a>

### References

#### Limiting references

*This place does not cover:*

Padlock casings	<a href="#">E05B 67/02</a>
Mounting of lock casings to the vehicles	<a href="#">E05B 79/04</a>
Mounting of lock casings to vehicles	<a href="#">E05B 85/02</a>

#### Informative references

*Attention is drawn to the following places, which may be of interest for search:*

Handles which do not operate the bolt	<a href="#">E05B 1/0015</a>
Fastening locks for glass wings	<a href="#">E05B 65/0025</a>

## E05B 11/00

Devices preventing keys from being removed from the lock {; Devices preventing falling or pushing out of keys (preventing turning of the key [E05B 13/00](#); keyhole guards [E05B 17/14](#); [E05B 35/086](#) takes precedence)}

### References

#### Limiting references

*This place does not cover:*

Using a pair of interlocked keys	<a href="#">E05B 35/086</a>
----------------------------------	-----------------------------

#### Informative references

*Attention is drawn to the following places, which may be of interest for search:*

Preventing turning of the key	<a href="#">E05B 13/00</a>
Keyholes guards	<a href="#">E05B 17/14</a>

## E05B 13/00

Devices preventing the key or the handle or both from being used {(covers or guards for keyholes [E05B 17/14](#))}

### Definition statement

*This place covers:*

Covers preventing access to the handle or key;

Devices for locking the handle;

Devices for disconnecting the handle;

### References

#### Limiting references

*This place does not cover:*

Electrically locking the handle	<a href="#">E05B 47/0657</a>
Electrically disconnecting the handle	<a href="#">E05B 47/0676</a>
Disconnecting the handle in a lock in which a sliding latch is used as a locking bolt	<a href="#">E05B 55/06</a>

#### Informative references

*Attention is drawn to the following places, which may be of interest for search:*

Closures or guards for keyholes	<a href="#">E05B 17/14</a>
---------------------------------	----------------------------

## E05B 15/00

### Other details of locks; Parts for engagement by bolts of fastening devices

#### Definition statement

*This place covers:*

Other details and parts of locks according to the following structure:

Devices for aligning wing and frame; Anti-rattling devices	<a href="#">E05B 15/0006</a>
Followers; bearings therefor	<a href="#">E05B 15/0013</a>
Energy storage by movement of the wing	<a href="#">E05B 15/002</a>
Adaptors cooperating with and acting on keys inserted in an existing lock	<a href="#">E05B 15/0026</a>
Spindles for handles, i.e. square spindles	<a href="#">E05B 15/0033</a>
Lost motion connections	<a href="#">E05B 15/004</a>
Ratchet mechanisms	<a href="#">E05B 15/0046</a>
Means providing a stable position for lock parts	<a href="#">E05B 15/0053</a>
Toggle levers	<a href="#">E05B 15/0086</a>
Gravity actuated lock parts	<a href="#">E05B 15/0093</a>
Escutcheon plates	<a href="#">E05B 15/02</a>
Striking plates, keepers	<a href="#">E05B 15/0205</a>
Spring arrangement in locks	<a href="#">E05B 15/04</a>
Lock wards	<a href="#">E05B 15/06</a>
Key guides	<a href="#">E05B 15/08</a>
Bolts of locks	<a href="#">E05B 15/10</a>
Tumblers	<a href="#">E05B 15/14</a>
Use of special materials for parts of the locks	<a href="#">E05B 15/16</a>

#### Relationships with other classification places

- Bolts or fastening devices for wings, specially for doors or windows: [E05C](#).

#### References

##### Informative references

*Attention is drawn to the following places, which may be of interest for search:*

Spring biasing means for moving the handle	<a href="#">E05B 3/065</a>
Wound springs	<a href="#">E05B 2015/0403</a>
Modifying spring characteristic or tension	<a href="#">E05B 2015/0431</a>
Attachments or mountings; Mounting of springs	<a href="#">E05B 2015/0437</a>
Units of springs; Two or more springs working together	<a href="#">E05B 2015/0448</a>
Folded springs	<a href="#">E05B 2015/0451</a>
Torsion springs of bar type	<a href="#">E05B 2015/0455</a>
Leaf springs; Non-wound wire springs	<a href="#">E05B 2015/0458</a>

## Informative references

Ring springs	<a href="#">E05B 2015/0462</a>
Cup- or dished-disc springs	<a href="#">E05B 2015/0465</a>
Made of one piece with a lock part	<a href="#">E05B 2015/0468</a>
Made of rubber, plastics or the like	<a href="#">E05B 2015/0472</a>
Heavy springs which cannot be operated by hand	<a href="#">E05B 2015/0482</a>
A single spring working on more than one part	<a href="#">E05B 2015/0486</a>
Overcenter springs	<a href="#">E05B 2015/0493</a>
Springs actuated by cams or the like	<a href="#">E05B 2015/0496</a>
For the whole lock	<a href="#">E05B 2015/1642</a>
For bolts	<a href="#">E05B 2015/165</a>
For escutcheons	<a href="#">E05B 2015/1657</a>
For lock housing	<a href="#">E05B 2015/1664</a>
For strikers	<a href="#">E05B 2015/1671</a>
For handle bearings	<a href="#">E05B 2015/1678</a>
Using special materials for keys	<a href="#">E05B 19/26</a>
Electric strikers	<a href="#">E05B 47/0046</a>
Gravity mechanisms for brief or suitcases	<a href="#">E05B 65/5292</a>
Staples for padlocks	<a href="#">E05B 67/383</a>
Gravity arrangements related to vehicle accidents	<a href="#">E05B 77/06</a> , <a href="#">E05B 77/12</a>
Anti-rattling means in vehicles	<a href="#">E05B 77/36</a>
Strikers for vehicles	<a href="#">E05B 85/04</a>
Bolts or detents for vehicle locks	<a href="#">E05B 85/20</a>
Fastening devices for wings other than locks or associated with locks	<a href="#">E05C</a>
Strikers for espagnolette locks	<a href="#">E05C 9/1808</a>
Securing part is formed by a spring, e.g. snaps	<a href="#">E05C 19/06</a>
Toggle fasteners	<a href="#">E05C 19/14</a>
Finger plates	<a href="#">E06B 7/285</a>

**E05B 15/16****Use of special materials for parts of locks****References****References out of a residual place**

*Examples of places in relation to which this place is residual:*

Use of special materials for handles	<a href="#">E05B 1/00</a>
--------------------------------------	---------------------------

**Informative references**

*Attention is drawn to the following places, which may be of interest for search:*

For reducing friction	<a href="#">E05B 17/007</a>
-----------------------	-----------------------------



For keys	<a href="#">E05B 19/26</a>
----------	----------------------------

## E05B 17/00

Accessories in connection with locks (buffers [E05F 5/00](#); means for preventing rattling of wings [E05F 7/04](#); means for taking the weight of the wing [E05F 7/06](#))

### Definition statement

*This place covers:*

Accessories in connection with locks according to the following structure:

Lock assembling or manufacturing	<a href="#">E05B 17/0004</a>
Defrosting, heating devices	<a href="#">E05B 17/0016</a>
Weather or dirt protection	<a href="#">E05B 17/002</a>
Devices for forcing the wing against its seat or to initiate opening of the wing	<a href="#">E05B 17/0025</a>
Damping means	<a href="#">E05B 17/0041</a>
Silencing devices, noise reduction	<a href="#">E05B 17/0045</a>
Preventing accidental lock-out	<a href="#">E05B 17/005</a>
Fraction or shear lines	<a href="#">E05B 17/0054</a>
Insulating, e.g. for limiting heat transfer	<a href="#">E05B 17/0075</a>
Devices for coupling the turning cylinder with the bolt operating member	<a href="#">E05B 17/04</a>
Templates or apparatus for installing locks	<a href="#">E05B 17/06</a>
Lubricating devices	<a href="#">E05B 17/08</a>
Illuminating devices	<a href="#">E05B 17/10</a>
Devices for removing key stuck in the lock	<a href="#">E05B 17/12</a>
Closures or guards for keyholes	<a href="#">E05B 17/14</a> - <a href="#">E05B 17/188</a>
Means independent of the locking mechanism for preventing unauthorised opening, e.g. by attack	<a href="#">E05B 17/20</a>
Means for operating or controlling locking mechanisms, e.g. switches, indicators	<a href="#">E05B 17/22</a>

### Relationships with other classification places

- Bolts or fastening devices for wings, specially for doors or windows: [E05C](#).

### References

#### Limiting references

*This place does not cover:*

Preventing dirt into the striker	<a href="#">E05B 15/029</a>
Illuminating devices attached to key rings	<a href="#">E05B 17/103</a>
With means carried by the lock for interlocking with the keeper	<a href="#">E05B 63/12</a>
Additional locking for safes responsive to attack	<a href="#">E05B 65/0082</a>

## Limiting references

Weather protection for vehicles	<a href="#">E05B 77/34</a>
Noise prevention, anti-rattling means in vehicles	<a href="#">E05B 77/36</a>
Cushion elements in vehicles	<a href="#">E05B 77/38</a>
Vehicle locks elements covered by a silencing coating	<a href="#">E05B 77/40</a>
Means for damping the movement of vehicle lock parts	<a href="#">E05B 77/42</a>
Burglar prevention in vehicles, e.g. by opening by unauthorised tool	<a href="#">E05B 77/44</a>
For assisting closing vehicle doors	<a href="#">E05B 81/20</a>
Making locksmith's goods of sheet metal, e.g. handles	<a href="#">B21D 53/38</a>
Drill jibs for work pieces	<a href="#">B23B 47/28</a>
Assembling in general	<a href="#">B23P 21/00</a>
Slotted or mortise work	<a href="#">B27F 5/12</a>
Using toothed wheels between lock cylinder and operating bars in espagnolette locks	<a href="#">E05C 9/023</a>
Templates for hinges	<a href="#">E05D 11/0009</a>
Anti-tampering devices for hinges	<a href="#">E05D 11/0018</a>
Stops or buffers preventing slamming of the wings	<a href="#">E05F 5/02</a>
Means for taking the weight of the wing	<a href="#">E05F 7/06</a>

**Informative references**

Attention is drawn to the following places, which may be of interest for search:

Devices for holding pieces while being painted	<a href="#">B05B 13/0292</a>
Means for preventing rattling of the wing	<a href="#">E05F 7/04</a>
Switches associated with locking means of the closing member	<a href="#">H01H 3/163</a>

**E05B 19/00**

**Keys; Accessories therefor** (key modifications or attachments preventing removal from the lock [E05B 11/005](#); key rings [A44B 15/00](#); key cases [A45C 11/32](#); key holders [A47G 29/10](#);) making keys, see the relevant places, e.g. [B21D 53/42](#); milling grooves in keys [B23C 3/35](#))

**Definition statement**

This place covers:

Keys for locks and accessories therefor and it has the following structure:

Key safes, i.e. lockable container for safe storage of one or a few keys	<a href="#">E05B 19/0005</a>
Key decoders	<a href="#">E05B 19/0011</a>
Key profiles	<a href="#">E05B 19/0017</a>
Construction of the key head, attaching the head to the shank	<a href="#">E05B 19/04</a>
Double or multiple keys	<a href="#">E05B 19/14</a>
Keys adjustable before use	<a href="#">E05B 19/18</a>

## Definition statement

Skeleton keys; devices for picking up locks	<a href="#">E05B 19/20</a>
Keys indicating whether the last operation was locking or unlocking	<a href="#">E05B 19/22</a>
Key distinguishing marks	<a href="#">E05B 19/24</a>
Use of special materials for keys	<a href="#">E05B 19/26</a>

**Relationships with other classification places**

- Individual entry or exist registers [G07C 9/00](#).

**References****Limiting references**

*This place does not cover:*

Key modifications or attachments preventing removal from the lock	<a href="#">E05B 11/005</a>
Key rings	<a href="#">A44B 15/00</a>
Key cases; e.g. purses for keys or small cases for extendable/retractable storage of several keys or shanks (however for single keys/shanks <a href="#">E05B 19/0082</a> , <a href="#">E05B 19/043</a> , <a href="#">E05B 19/046</a> )	<a href="#">A45C 11/32</a>
Key holders; boards or cabinets for key storage	<a href="#">A47G 29/10</a>
Rescue tools with forcing action	<a href="#">A62B 3/005</a>
Making keys	<a href="#">B21D 53/42</a>
Milling grooves in keys	<a href="#">B23C 3/35</a>

**Informative references**

*Attention is drawn to the following places, which may be of interest for search:*

Illuminating devices on keys	<a href="#">E05B 17/103</a>
Locks for use with special keys	<a href="#">E05B 35/00</a>
Keys with magnets	<a href="#">E05B 47/0045</a>
Mechanical keys for electric permutation locks	<a href="#">E05B 49/00</a>
Key manufacturing	<a href="#">B23P 15/005</a>
Non-mechanical keys for electronic locks	<a href="#">G07C 9/00944</a>

**E05B 21/00**

**Locks with lamelliform tumblers {which are not set by the insertion of the key and} in which the tumblers do not follow the movement of the bolt {e.g. Chubb-locks}**

**Definition statement**

*This place covers:*

Locks with plate tumblers wherein, when the correct key is inserted into the lock, the tumblers are not immediately moved to their unlocked positions. Only when the key is thereafter turned, the tumblers are moved to their unlocked positions. The movement of the tumblers does not follow the movement

Definition statement

of the bolt, which means that the tumblers usually are mounted to the lock housing. This group has the following structure:

Chubb locks	<a href="#">E05B 21/00</a>
Cylinder locks, e.g. Protector locks	<a href="#">E05B 21/06</a>
Cylinder locks of the sliding-plate tumble type	<a href="#">E05B 21/063</a>
Cylinder locks of the rotary-disc tumbler type	<a href="#">E05B 21/066</a>

EP 0 903 455 A2

FIG.1

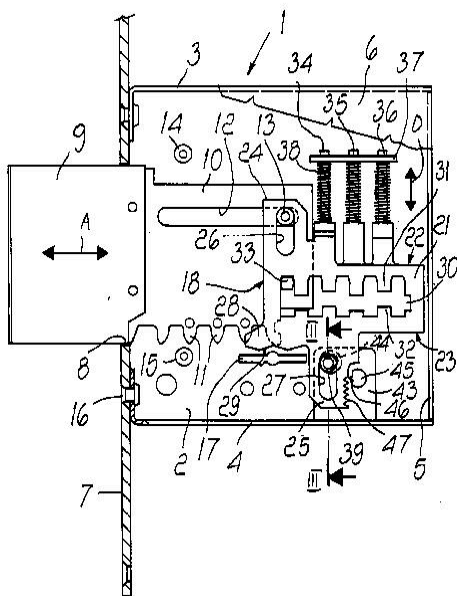

EP0903455

**Special rules of classification**

[E05B 21/00](#) should contain locks with tumblers moved by rotation of the key in which, when the key is turned, the movement of the tumblers is independent of the movement of the bolt, e.g. the tumblers are guided in the lock casing for movement in a direction perpendicularly to the movement direction of the bolt.

**E05B 21/06****Cylinder locks, e.g. protector locks****Definition statement**

*This place covers:*

Cylinder locks wherein the tumblers are not set by pushing the key in.

*Fig. 1*

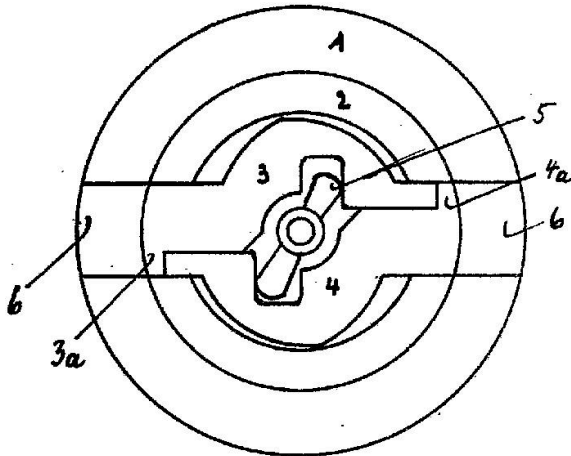

DE560425

**E05B 21/066**

{of the rotary-disc tumbler type (tumblers which are set by inserting the key [E05B 29/0013](#))}

**Definition statement**

*This place covers:*

Cylinder locks with rotary-disc tumblers wherein the tumblers are not set by pushing the key in.

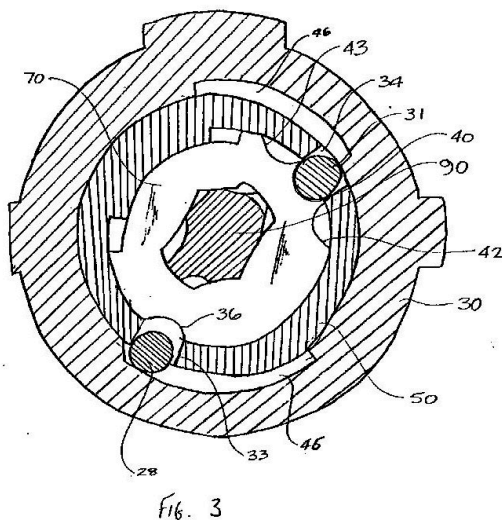

*Fig. 3*

EP0978608

**Special rules of classification**

Cylinder locks with rotary tumblers, such that when the key is inserted into the lock the tumblers are set should be classified in [E05B 29/0013](#).

**E05B 23/00**

**Locks with lamelliform tumblers {which are not set by the insertion of the key and} in which the tumblers follow the movement of the bolt**

**Definition statement**

*This place covers:*

Locks, other than cylinder locks, wherein when the key is turned to move the bolt the tumblers follow the movement of the bolt, e.g. the tumblers are pivotally mounted on the bolt.

N° 768.524 Société Anonyme Pl. unique  
Etablissements E. Maquennehen & Imbert

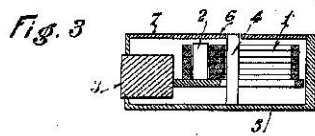
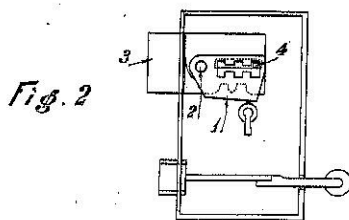
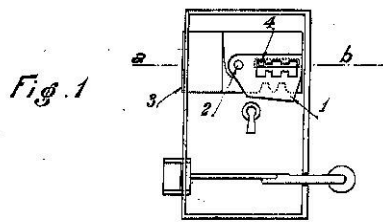

FR768524

## E05B 27/00

**Cylinder locks {or other locks} with tumbler pins or balls that are set by pushing the key in**

### Definition statement

*This place covers:*

Cylinder locks with tumbler pins or balls which are set by pushing the key in and parts thereof, i.e. rotors, stators and tumblers.

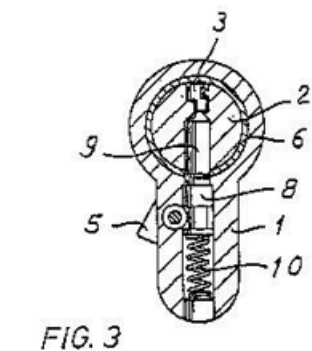
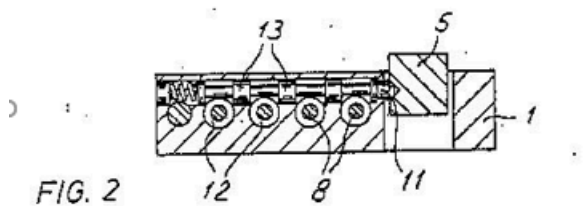
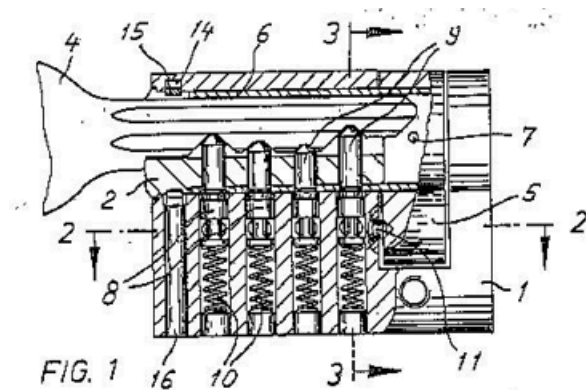

### References

#### Informative references

Attention is drawn to the following places, which may be of interest for search:

Casing of cylinder locks	<a href="#">E05B 9/04</a>
Fastening of lock cylinders to the wing	<a href="#">E05B 9/084</a>
Fastening plugs or cores to an outer stator	<a href="#">E05B 9/086</a>
Coupling devices for the two halves of double cylinder locks	<a href="#">E05B 9/10</a>
Cylinder locks with magnetic tumblers	<a href="#">E05B 47/0044</a>
Cylinder locks with electromagnetic control	<a href="#">E05B 47/0611</a>

Lock cylinder arrangements vehicles	<a href="#">E05B 85/06</a>
-------------------------------------	----------------------------

## E05B 29/00

Cylinder locks {and other locks} with plate tumblers which are set by pushing the key in {(fastening of cylinders, rotors, plugs or cores [E05B 9/084](#); with magnetic tumblers [E05B 47/0044](#); with electromagnetic control [E05B 47/0611](#))}

### Definition statement

*This place covers:*

Cylinder locks with plate tumblers which are set by pushing the key in. The plate tumblers can slide, rotate or float, e.g. slide and rotate.

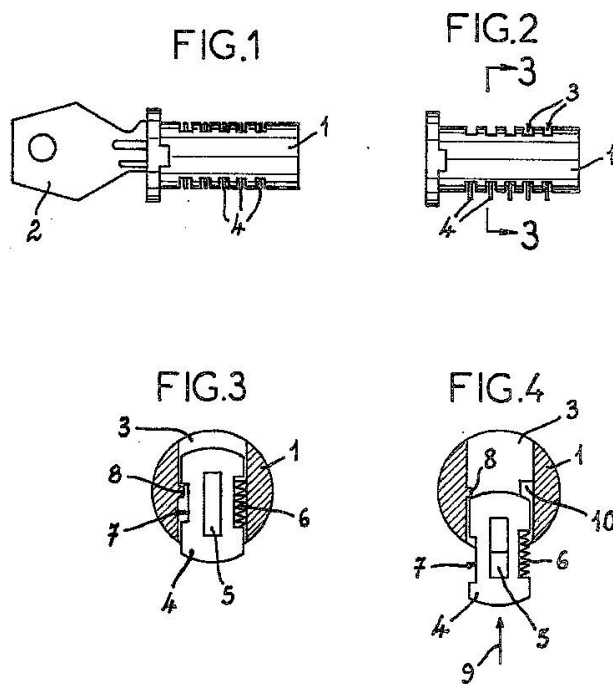

FR768524

### References

#### Limiting references

*This place does not cover:*

Lock cylinder arrangements vehicles	<a href="#">E05B 85/06</a>
-------------------------------------	----------------------------

#### Informative references

*Attention is drawn to the following places, which may be of interest for search:*

Casing of cylinder locks	<a href="#">E05B 9/04</a>
Fastening of lock cylinders to the wing	<a href="#">E05B 9/084</a>
Fastening plugs or cores to an outer stator	<a href="#">E05B 9/086</a>
Coupling devices for the two halves of double cylinder locks	<a href="#">E05B 9/10</a>
Cylinder locks with magnetic tumblers	<a href="#">E05B 47/0044</a>
Cylinder locks with electromagnetic control	<a href="#">E05B 47/0611</a>



**E05B 29/0013**

{with rotating plate tumblers ([E05B 29/0033](#) takes precedence; plate tumblers which are not set by inserting the key [E05B 21/06](#))}

**Definition statement**

*This place covers:*

Cylinder locks with rotary tumblers, wherein, when the key is inserted into the lock the tumblers are set to the right combination.

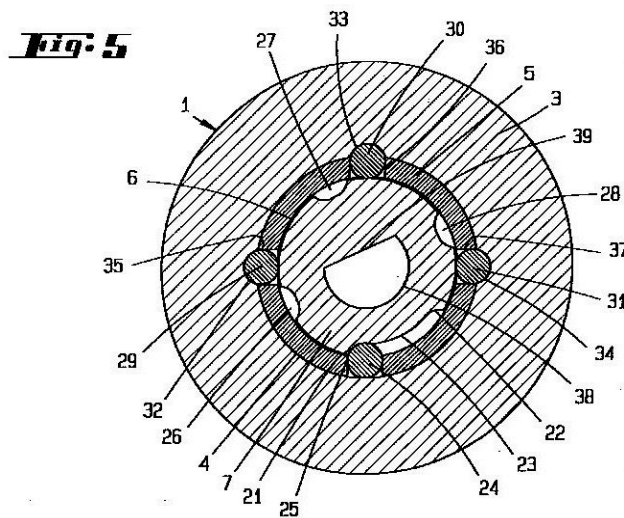

EP 0 622 508 A1

EP0622508

**Special rules of classification**

Cylinder locks with rotary tumblers, wherein, when the key is inserted into the lock the tumblers are not set, e.g. do not move, and when during rotation of the key the tumblers are set to the right combination should be classified in [E05B 21/066](#).

## E05B 31/00

### Cylinder locks with both tumbler pins or balls and plate tumblers

#### Definition statement

*This place covers:*

Cylinder locks with both tumbler pins or balls and plate tumblers which are set by pushing the key in.

2758847

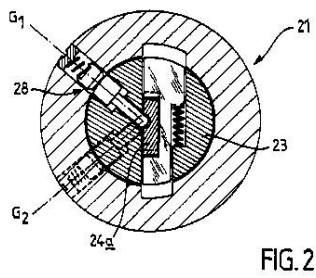
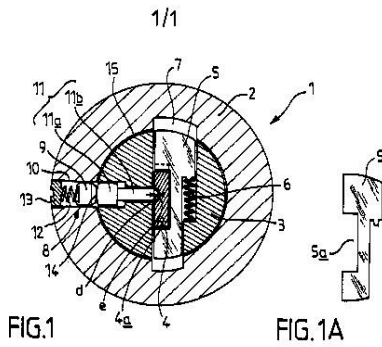

FR2758847

**E05B 33/00****Cylinder locks in which the bolt is moved by means other than the key****Definition statement**

*This place covers:*

Cylinder locks with tumblers which are set by pushing the key in and wherein the rotor is moved by means other than the key.

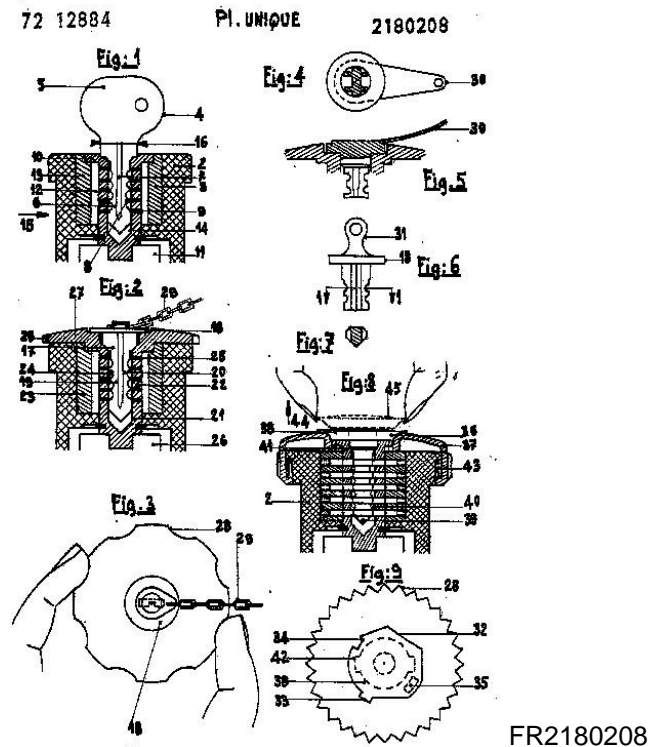
**References****Informative references**

*Attention is drawn to the following places, which may be of interest for search:*

Cylinder locks operated by handles, e.g. by knobs	<a href="#">E05B 2009/046</a>
Cylinder locks with electromagnetic control operated by handles, e.g. knobs	<a href="#">E05B 47/0615</a>

**E05B 35/00****Locks for use with special keys or a plurality of keys {; keys therefor}****Definition statement**

*This place covers:*

This group has the following structure:

With key identifying function	<a href="#">E05B 35/001</a>
For flexible keys	<a href="#">E05B 35/002</a>

## Definition statement

For keys with movable bits	<a href="#">E05B 35/003</a>
For rack- or pinion-like keys	<a href="#">E05B 35/006</a>
The key being a perforated card or the like	<a href="#">E05B 35/007</a>
For simple tool-like keys	<a href="#">E05B 35/008</a>
Which can be shifted laterally or rotated about an axis perpendicular to the key axis	<a href="#">E05B 35/02</a>
For screw keys	<a href="#">E05B 35/06</a>
Operable by a plurality of key	<a href="#">E05B 35/08</a>
With master and pass keys	<a href="#">E05B 35/10</a>
Requiring the use of two keys	<a href="#">E05B 35/12</a>
With keys that different parts operate separate mechanisms	<a href="#">E05B 35/14</a>

## References

### Limiting references

*This place does not cover:*

Keys adjustable before use	<a href="#">E05B 19/18</a>
Mechanical locks operated by cards having magnets	<a href="#">E05B 47/0043</a>
Keys with magnets	<a href="#">E05B 47/0045</a>
Mechanical keys for electric permutation locks	<a href="#">E05B 49/00</a>
Non-mechanical keys for electronic locks	<a href="#">G07C 9/00944</a>

### Informative references

*Attention is drawn to the following places, which may be of interest for search:*

Key; accessories therefor	<a href="#">E05B 19/00</a>
Cylinder locks with tumbler pins or balls	<a href="#">E05B 27/00</a>
Cylinder locks with plate tumblers	<a href="#">E05B 29/00</a>

## E05B 37/00

Permutation {or combination} locks ({handles with combination locks [E05B 13/103](#); keyhole guards with combination locks [E05B 17/145](#);} electric permutation locks [E05B 49/00](#)); Puzzle locks

### Definition statement

*This place covers:*

Mechanical combination locks, padlocks with combination locks and puzzle locks.

### Relationships with other classification places

- Individual entry or exist registers [G07C 9/00](#).

## References

### Limiting references

*This place does not cover:*

Handles with combination locks	<a href="#">E05B 13/103</a>
Keyhole guards with combination locks	<a href="#">E05B 17/145</a>
Electric permutation locks	<a href="#">E05B 49/00</a>

### Application-oriented references

*Examples of places where the subject matter of this place is covered when specially adapted, used for a particular purpose, or incorporated in a larger system:*

Permutation locks for container closures	<a href="#">B65D 55/145</a>
--	-----------------------------

### Informative references

*Attention is drawn to the following places, which may be of interest for search:*

Alarms for combination locks	<a href="#">E05B 45/061</a>
Electronic permutation locks	<a href="#">G07C 9/00</a>
Combination switches	<a href="#">H01H 27/10</a>

## E05B 39/00

**Locks giving indication of {authorised} or unauthorised unlocking {(with key identification means [E05B 35/001](#); alarm locks [E05B 45/00](#))}**

### Definition statement

*This place covers:*

Locks with means giving indication of authorised or unauthorised unlocking and also locks with non-electronic counting or registering devices.

### Relationships with other classification places

- Means for indicating unauthorised opening of container closures [B65D](#)
- Registering indicating or recording the time [G07C 1/00](#);
- Seals [G09F 3/00](#);

## References

### Limiting references

*This place does not cover:*

Closures for postal containers with special means for indicating unauthorised opening	<a href="#">B65D 27/30</a>
Locking devices for container closures with means for indicating unauthorised opening	<a href="#">B65D 55/02</a>
Time recording locks (electronically)	<a href="#">G07C 1/32</a>
Security seals	<a href="#">G09F 3/03</a>

**Informative references**

Attention is drawn to the following places, which may be of interest for search:

Locks with key identification function	<a href="#">E05B 35/001</a>
Alarm locks	<a href="#">E05B 45/00</a>
Vehicle locks with means for sealing	<a href="#">E05B 83/14</a>

**Special rules of classification**

As a general rule, if the means for giving indication for unauthorised opening has to be broken and cannot be reused without being replaced, it is not considered as a lock in the sense of [E05B](#), but as a seal in the sense of [G09F 3/00](#).

**E05B 39/02**

**with destructible seal closures or paper closures**

**References****Informative references**

Attention is drawn to the following places, which may be of interest for search:

Seals per se	<a href="#">G09F 3/00</a>
--------------	---------------------------

**E05B 41/00**

**Locks with visible indication as to whether the lock is locked or unlocked  
{(indicator lights [E05B 17/10](#))}**

**References****Informative references**

Attention is drawn to the following places, which may be of interest for search:

Illuminating devices	<a href="#">E05B 17/10</a>
Switches, indicators	<a href="#">E05B 17/22</a>

**E05B 43/00**

**Time locks**

**Definition statement**

*This place covers:*

Time locks, e.g. with delaying means and timers devices controlling electrically operated locks.

**Relationships with other classification places**

- Mechanically driven clocks or watches [G04B 23/00](#)
- Registering indicating or recording the time [G07C 1/00](#);
- Time medicine dispensers [A61G 7/00](#);

## References

### Informative references

Attention is drawn to the following places, which may be of interest for search:

Electrically operated locks	<a href="#">E05B 47/00</a>
Electric permutation locks	<a href="#">E05B 49/00</a>
Medicine programmed dispensers	<a href="#">A61J 7/04</a>
Clocks or clock mechanisms with attached or built-in means operating any device at preselected times or after preselected time-intervals	<a href="#">G04B 23/00</a>
Time recording locks	<a href="#">G07C 1/32</a>

## E05B 45/00

### Alarm locks

#### Definition statement

This place covers:

Locks provided with mechanical or electrically operated alarms, including chain, cables or padlock with alarms.

#### Relationships with other classification places

- Alarms systems [G08B](#)
- Vehicle fittings preventing or indicating unauthorised use or theft [B60R 25/00](#);
- Appliances indicating unauthorised use or theft of cycles [B62H 5/00](#);
- Safe or strong rooms [E05G 1/00](#);

## References

### Informative references

Attention is drawn to the following places, which may be of interest for search:

Electric operated locks	<a href="#">E05B 47/00</a>
Electric permutation locks	<a href="#">E05B 49/00</a>
Vehicle theft alarms	<a href="#">B60R 25/10</a>
Bicycle theft alarms	<a href="#">B62H 5/20</a>
Safe or strong rooms with alarms	<a href="#">E05G 1/10</a>
Detonating alarm devices in general	<a href="#">G08B 3/14</a>
Alarm devices(other than the lock itself) actuated by tampering with fastenings in general	<a href="#">G08B 13/06</a>

## E05B 47/00

**Operating or controlling locks or other fastening devices by electric or magnetic means (electric permutation locks [E05B 49/00](#))**

### Definition statement

*This place covers:*

Locks or other fastening devices comprising electric or magnetic means for operation or control the lock functions. It has the following main structure:

### References

#### Limiting references

*This place does not cover:*

Electric permutation locks	<a href="#">E05B 49/00</a>
----------------------------	----------------------------

#### Application-oriented references

*Examples of places where the subject matter of this place is covered when specially adapted, used for a particular purpose, or incorporated in a larger system:*

Power-actuated vehicle locks	<a href="#">E05B 81/00</a>
------------------------------	----------------------------

#### Informative references

*Attention is drawn to the following places, which may be of interest for search:*

Motor-operated	<a href="#">E05B 17/0029</a>
Electrically-operated	<a href="#">E05B 17/147</a>
Devices for holding wings in open position or limiting movement of wings by magnetic or electromagnetic attraction	<a href="#">E05C 17/56</a>
Device holding the wing by magnetic or electromagnetic attraction	<a href="#">E05C 19/16</a>
Key switches	<a href="#">H01H 27/00</a>

## E05B 49/00

**Electric permutation locks; Circuits therefor {; Mechanical aspects of electronic locks; Mechanical keys therefor (arrangements for sensing or reading record carriers [G06K 7/00](#); mechanisms including electronic locks actuated by nonmechanical keys such as passive and active electrical keys and other data carriers [G07C 9/00](#), [G07F 7/00](#); electronic switching [H03K 17/00](#))}**

### Definition statement

*This place covers:*

Electric permutation locks and mechanical keys therefor. It has the following main structure:

Keys with mechanical characteristics	<a href="#">E05B 49/002</a>
Keys actuating mechanical switches	<a href="#">E05B 49/004</a>
Keys actuating opto-electronic devices	<a href="#">E05B 49/006</a>



### Relationships with other classification places

- Methods of sensing or reading record carriers [G06K 7/00](#);
- Recognition of data, record carriers [G07F 7/00](#);
- Mechanisms including electronic locks actuated by non mechanical keys such as passive and active electrical keys: [G07C 9/00](#)
- Mechanism actuated by coded cards: [G07F 7/00](#)
- Electronic switching or gating: [H03K 17/00](#)

### References

#### Limiting references

*This place does not cover:*

Electric operated or controlled locks	<a href="#">E05B 47/00</a>
Electronic locks actuated by non mechanical keys	<a href="#">G07C 9/00</a>
Non-mechanical keys for electronic locks	<a href="#">G07C 9/00944</a>

#### Application-oriented references

*Examples of places where the subject matter of this place is covered when specially adapted, used for a particular purpose, or incorporated in a larger system:*

Key operated switches	<a href="#">H01H 27/00</a>
-----------------------	----------------------------

## E05B 51/00

### Operating or controlling locks or other fastening devices by other non-mechanical means

#### Definition statement

*This place covers:*

Operating or controlling locks or other fastening devices by other non-purely mechanical means, such as e.g. by bimetallic or memory-shaped elements, or by pneumatic or hydraulic means.

### References

#### Limiting references

*This place does not cover:*

Opening a panic door under force or pressure on the surface of the door	<a href="#">E05B 65/102</a>
Locking several vehicle wings simultaneously by pneumatic or hydraulic means	<a href="#">E05B 77/50</a>
Pneumatic or hydraulic driven locks for vehicles and actuators or circuits therefor	<a href="#">E05B 81/10</a>
Hydraulic power locks for wing closers	<a href="#">E05F 3/223</a>
Power operated mechanism for wings with pressure medium	<a href="#">E05F 15/50</a>

**Informative references**

Attention is drawn to the following places, which may be of interest for search:

Thermo-electric actuators	<a href="#">E05B 47/0009</a>
---------------------------	------------------------------

**E05B 53/00****Operation or control of locks by mechanical transmissions, e.g. from a distance****Definition statement**

*This place covers:*

Locks operated by mechanical transmission including foot-operated locks and locks operated by flexible means, e.g. cables or Bowden cables.

**Relationships with other classification places**

- Bolts or fastening devices for wings, specially for doors or windows: [E05C](#);
- Devices for moving wings into open or closed positions: [E05F](#);

**References****Limiting references**

*This place does not cover:*

Flexible connections between lock parts in vehicles	<a href="#">E05B 79/20</a>
Mechanical operating mechanisms for wings	<a href="#">E05F 9/00</a> , <a href="#">E05F 11/00</a>

**Application-oriented references**

*Examples of places where the subject matter of this place is covered when specially adapted, used for a particular purpose, or incorporated in a larger system:*

Means for transmitting linear movement in a flexible sheathing, e.g. Bowden mechanisms	<a href="#">F16C 1/10</a>
--	---------------------------

**Informative references**

Attention is drawn to the following places, which may be of interest for search:

For simultaneously actuated bolts	<a href="#">E05B 63/14</a>
For car boot lids or bonnets	<a href="#">E05B 83/24</a>
For fuel inlet covers	<a href="#">E05B 83/34</a>

## E05B 55/00

### Locks in which a sliding latch is used also as a locking bolt

#### Definition statement

*This place covers:*

Locks in which a sliding latch is used also as a locking bolt, e.g. cylindrical or tubular locks. It includes also locks in which the handle can be disconnected or locks in which the bolt is secured by the action of a trigger member cooperating with the frame.

#### References

##### Limiting references

*This place does not cover:*

Electrically disconnecting the handle	<a href="#">E05B 47/0676</a>
A latch bolt being initially retained in an intermediate position and subsequently projected to its full extend when the wing is closed	<a href="#">E05B 63/202</a>

##### Informative references

*Attention is drawn to the following places, which may be of interest for search:*

Devices for disconnecting the handle	<a href="#">E05B 13/005</a> , <a href="#">E05B 13/101</a>
Cylindrical or tubular latches	<a href="#">E05C 1/163</a>

## E05B 57/00

### Locks in which a pivoted latch is used also as locking means

#### Definition statement

*This place covers:*

Locks in which a pivoted latch is also can be dead locked.

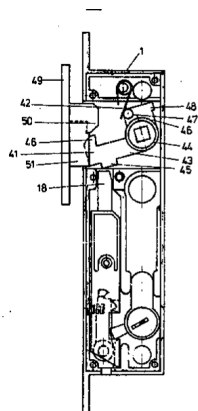

AU556425

## E05B 59/00

### Locks with latches separate from the lock-bolts or with a plurality of latches or lock-bolts

#### Definition statement

*This place covers:*

Locks with latches in addition to lock-bolts or dead bolts.

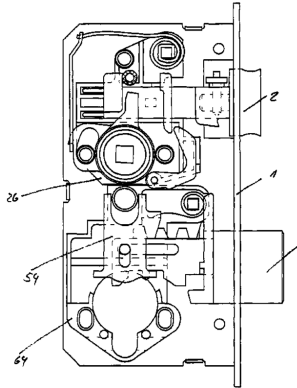

EP0792980

#### Relationships with other classification places

- Bolts or fastening devices for wings, specially for doors or windows: [E05C](#).

#### References

##### Informative references

Attention is drawn to the following places, which may be of interest for search:

Bolts with multiple head	<a href="#">E05B 15/108</a>
Locks in which a sliding latch is used also as a locking bolt	<a href="#">E05B 55/00</a>
Other locks with provision for latching	<a href="#">E05B 61/00</a>
Locks with a rotary bolt without provision of latching	<a href="#">E05B 63/0013</a>
Locks with a pivoting bolt without provision of latching	<a href="#">E05B 63/0017</a>
Mortise locks	<a href="#">E05B 63/08</a>
Locks with several bolts	<a href="#">E05B 63/14</a>
Automatic locks	<a href="#">E05B 63/20</a>
Espagnolette locks	<a href="#">E05C 9/00</a>

## E05B 61/00

### Other locks with provision for latching

#### Definition statement

*This place covers:*

Locks which provision of latching not covered by the groups [E05B 55/00](#), [E05B 57/00](#) or [E05B 59/00](#).

## E05B 63/00

### Locks {or fastenings} with special structural characteristics

#### Definition statement

*This place covers:*

Locks or fastenings with special structural characteristics

#### Relationships with other classification places

Bolts or fastening devices for wings, specially for doors or windows: [E05C](#)

#### References

##### Application-oriented references

*Examples of places where the subject matter of this place is covered when specially adapted, used for a particular purpose, or incorporated in a larger system:*

Using bolts interlocking with notches for attaching vehicle seats to the vehicle chassis	<a href="#">B60N 2/01533</a>
Safety devices for wings opening about a vertical as well as a horizontal axis	<a href="#">E05D 15/526</a>

## E05B 63/14

Arrangement of several locks or locks with several bolts, e.g. arranged one behind the other ({locks having bolts with multiple head [E05B 15/108](#);} with provision for latching [E05B 59/00](#), [E05B 61/00](#))

#### References

##### Limiting references

*This place does not cover:*

Bolts with multiple head	<a href="#">E05B 15/108</a>
With provision for latching	<a href="#">E05B 59/00</a> , <a href="#">E05B 61/00</a>

##### Application-oriented references

*Examples of places where the subject matter of this place is covered when specially adapted, used for a particular purpose, or incorporated in a larger system:*

Locks for sliding wings having simultaneously pivoting double hook-like locking members	<a href="#">E05B 65/0858</a>
Bolts for vehicle locks rotating about an axis and being bifurcated	<a href="#">E05B 85/245</a>
Double bolts being bifurcated and spring actuated for wings, doors or windows	<a href="#">E05C 3/28</a> ; <a href="#">E05C 3/34</a>

##### Informative references

*Attention is drawn to the following places, which may be of interest for search:*

Locks for keys with several bits	<a href="#">E05B 35/14</a>
----------------------------------	----------------------------

Arrangements of simultaneously actuated bolts or other securing devices at well-separated positions on the same wing	<a href="#">E05C 9/00</a>
--	---------------------------

## E05B 63/24

Arrangements in which the fastening members which engage one another are mounted respectively on the wing and the frame and are both movable, e.g. for release by moving either of them ({operating or controlling locks using electric or magnetic means in the striker or on the frame [E05B 47/0046](#), adaptation of locks locking the bolt by an electromagnet in the striker [E05B 47/0696](#), locks with means carried by the bolt for interlocking with the keeper and having additional bolt in the striker [E05B 63/128](#);} hasp locks [E05B 65/48](#))

### References

#### Limiting references

*This place does not cover:*

Operating or controlling locks using electric or magnetic means in the striker or on the frame	<a href="#">E05B 47/0046</a>
Adaptation of locks - locking the bolt by an electromagnet in the striker	<a href="#">E05B 47/0696</a>
Locks with means carried by the bolt for interlocking with the keeper and having additional bolt in the striker	<a href="#">E05B 63/128</a>
Hasp locks	<a href="#">E05B 65/48</a>

#### Informative references

*Attention is drawn to the following places, which may be of interest for search:*

Hasp fastenings	<a href="#">E05C 19/08</a>
-----------------	----------------------------

## E05B 65/00

### Locks {or fastenings} for special use

#### Definition statement

*This place covers:*

Locks or fastenings for special use.

### References

#### Application-oriented references

*Examples of places where the subject matter of this place is covered when specially adapted, used for a particular purpose, or incorporated in a larger system:*

Weight arrangement in locks	<a href="#">E05B 15/0093</a>
Arrangements of fasteners for travelling bags	<a href="#">A45C 13/10</a>
Drawers for tables, cabinets or like furniture	<a href="#">A47B 88/00</a>
Coffin closures	<a href="#">A61G 17/02</a>
Arrangement of water tight doors in bulkheads	<a href="#">B63B 43/24</a>

## Application-oriented references

Applications of locks for container closures	<a href="#">B65D 55/14</a>
Locking devices for elevator doors or gates	<a href="#">B66B 13/16</a>
Locking devices for manhole covers	<a href="#">E02D 29/1427</a>
Connections for building structures with rotatable locking means	<a href="#">E04B 1/6183</a>
Vertically sliding sectional doors	<a href="#">E05D 15/24</a>
Gas-proof doors or similar closures	<a href="#">E06B 5/14</a>
Wire gates	<a href="#">E06B 11/021</a>
Covers or closures for pressure vessels	<a href="#">F16J 13/00</a>
Details of doors or covers of refrigerators	<a href="#">F25D 23/028</a>
Latching mechanisms for covers of portable computers	<a href="#">G06F 1/1679</a>
Enclosures for switching arrangements	<a href="#">H02B 1/063</a>

**Informative references**

Attention is drawn to the following places, which may be of interest for search:

Insulating, e.g. for limiting heat transfer	<a href="#">E05B 17/0075</a>
Locks with fracturable glass or the like	<a href="#">E05B 39/025</a>
Locks with visible indication as to whether the lock is locked or unlocked	<a href="#">E05B 41/00</a>
Locks for vehicles	<a href="#">E05B 77/00-E05B 85/00</a>
Locks for sliding doors of vehicles	<a href="#">E05B 83/04</a> , <a href="#">E05B 83/40</a>
Buckles, similar fasteners for interconnecting straps	<a href="#">A44B 11/00</a>
Slide fasteners	<a href="#">A44B 19/00</a>
Door latches for dish washers	<a href="#">A47L 15/4259</a>
Locking devices for vehicle seats	<a href="#">B60N 2/00</a>
Hatch fastening in ships	<a href="#">B63B 19/24</a>
Locking devices for container closures	<a href="#">B65D 55/02</a>
Locking or fastening means for lids or covers of refuse receptacles	<a href="#">B65F 1/1615</a>
Safety arrangements for laundry washing machines	<a href="#">D06F 37/42</a>
Securing means for doors of laundry washing machines	<a href="#">D06F 39/14</a>
Locks for two wings	<a href="#">E05C 7/00</a>
Holding sliding wings open	<a href="#">E05C 17/60</a>
Toggle fasteners	<a href="#">E05C 19/14</a>
Devices for holding the wing by magnetic attraction	<a href="#">E05C 19/16</a>
Magnetic gaskets	<a href="#">E05C 19/161</a>
Locking of doors, covers, guards acting in conjunction with the control or operation of a machine	<a href="#">F16P 3/08</a>
Latches for doors specially adapted for stoves	<a href="#">F24C 15/022</a>
Coin freed locks	<a href="#">G07F 17/12</a> , <a href="#">G07F 17/14</a>
Switches operated by a key	<a href="#">H01H 27/00</a>

**E05B 65/08****for sliding wings****Definition statement**

*This place covers:*

Locks or fastenings for sliding wings.

**References****Informative references**

*Attention is drawn to the following places, which may be of interest for search:*

For vehicles	<a href="#">E05B 83/04</a> , <a href="#">E05B 83/40</a>
Holding sliding wings open	<a href="#">E05C 17/60</a>

**E05B 65/0817****{with additional movement, e.g. toggle, overcenter, excentric}****References****Informative references**

*Attention is drawn to the following places, which may be of interest for search:*

Connections between frontal surfaces of slab-shaped building elements with rotatable locking means co-operating with a recess	<a href="#">E04B 1/6183</a>
Toggle fasteners in general	<a href="#">E05C 19/14</a>

**E05B 65/44****for furniture (for drawers [E05B 65/46](#))****Definition statement**

*This place covers:*

Locks for furniture.

**References****Limiting references**

*This place does not cover:*

Locks for drawers	<a href="#">E05B 65/46</a>
-------------------	----------------------------

**E05B 65/46****for drawers****Definition statement**

*This place covers:*

Locks for drawers.



## References

### Informative references

Attention is drawn to the following places, which may be of interest for search:

For electronic unit cases	<a href="#">H05K 7/1401</a>
---------------------------	-----------------------------

## E05B 65/468

using rotary locking bars ([E05B 65/465](#), [E05B 65/467](#) take precedence)

### Definition statement

*This place covers:*

Locks for two or more drawers using rotary locking bars.

## References

### Limiting references

*This place does not cover:*

Drawer interlock or anti-tilt mechanisms with rotary locking bars	<a href="#">E05B 65/465</a>
Locking bars secured in front of the drawers	<a href="#">E05B 65/467</a>

## E05B 65/52

Other locks for chests, boxes, trunks, baskets, travelling bags, or the like

## References

### References out of a residual place

*Examples of places in relation to which this place is residual:*

Permutation locks	<a href="#">E05B 37/00</a>
Hasp locks	<a href="#">E05B 65/48</a>
Locking slide fasteners	<a href="#">A44B 19/301</a>
Toggles	<a href="#">E05C 19/14</a>

### Informative references

Attention is drawn to the following places, which may be of interest for search:

Closures for bags or trunks	<a href="#">A45C 13/06</a> , <a href="#">A45C 13/10</a> , <a href="#">A45C 13/16</a>
-----------------------------	---

## E05B 67/00

Padlocks (permutation locks [E05B 37/00](#)); Details thereof

### Definition statement

*This place covers:*

Padlocks; Details thereof

## References

### Limiting references

*This place does not cover:*

Permutation locks	<a href="#">E05B 37/00</a>
-------------------	----------------------------

### Application-oriented references

*Examples of places where the subject matter of this place is covered when specially adapted, used for a particular purpose, or incorporated in a larger system:*

Anti-theft devices for vehicles operating on steering mechanism	<a href="#">B60R 25/02</a>
---	----------------------------

### Informative references

*Attention is drawn to the following places, which may be of interest for search:*

Chain cables or padlocks with alarms	<a href="#">E05B 45/005</a>
Hasp locks	<a href="#">E05B 65/48</a>
Lockable hangers or hanger racks	<a href="#">E05B 69/006</a>
Hasp fastenings	<a href="#">E05C 19/08</a>

## E05B 69/00

### Devices for locking clothing; Lockable clothing holders or hangers

#### Definition statement

*This place covers:*

Devices for locking clothing, shoes, lockable hangers or hanger racks and lockable clothing hooks.

#### Relationships with other classification places

Shoe hangers, clothing, dress or hat holders: [A47G 25/00](#)

## References

### Limiting references

*This place does not cover:*

Chain cables or padlocks with alarms	<a href="#">E05B 45/005</a>
Anti-theft tags or monitors	<a href="#">E05B 73/0017</a>

### Application-oriented references

*Examples of places where the subject matter of this place is covered when specially adapted, used for a particular purpose, or incorporated in a larger system:*

Shoe hangers	<a href="#">A47G 25/005</a>
Dress holders	<a href="#">A47G 25/02</a>
Cloth hooks	<a href="#">A47G 25/06</a>
Hat holders	<a href="#">A47G 25/10</a>

Clothing hangers	<a href="#">A47G 25/12</a>
------------------	----------------------------

### **Informative references**

Attention is drawn to the following places, which may be of interest for search:

Anti-theft monitors	<a href="#">E05B 73/0017</a>
Dress or hat holders in general	<a href="#">A47G 25/00</a>

## **E05B 69/02**

Lockable clothing hooks (coin-controlled locking hooks [G07F 17/10](#))

### **References**

#### **Limiting references**

This place does not cover:

For means for safe-keeping of property, left temporarily, e.g. by fastening the property	<a href="#">G07F 17/10</a>
--	----------------------------

## **E05B 71/00**

Locks specially adapted for bicycles, other than padlocks ({locks integral with holders for parking or storing bicycles [B62H 3/00](#);} locks integral with cycles [B62H 5/00](#))

### **Definition statement**

This place covers:

Locks specially adapted for bicycles, other than padlocks

### **Relationships with other classification places**

Locks integral with cycles, cycles stands: [B62H](#)

### **References**

#### **Limiting references**

This place does not cover:

Locks integral with holders for parking bicycles	<a href="#">B62H 3/00</a>
Locks integral with cycles	<a href="#">B62H 5/00</a>

### **Informative references**

Attention is drawn to the following places, which may be of interest for search:

Supporting devices for attaching articles to cycles	<a href="#">B62J 11/00</a>
---	----------------------------

## E05B 73/00

Devices for locking portable objects against unauthorised removal; Miscellaneous locking devices {(motorcycle helmets [A42B 3/0413](#); supporting arrangements specially adapted for fastening helmets [B62J 11/24](#); gun racks [A47B 81/005](#); showcases with theft protection [A47F 3/002](#); anti-theft means for peg-boards, grids or rods for hanging merchandise [A47F 5/0861](#); show stands, hangers, shelves with provision against unauthorised removal [A47F 7/024](#); for self-service hand-carts [A47F 10/04](#); locking skis [A63C 11/004](#); locking bolts, nuts or pins [F16B 41/00](#)}}

### Definition statement

*This place covers:*

Devices for locking portable objects against unauthorised removal; Miscellaneous locking devices

### Relationships with other classification places

- Special furniture, fittings or accessories for shops: [A47F](#)
- Vehicle fittings: [B60R](#)

### References

#### Limiting references

*This place does not cover:*

Locks specially adapted for bicycles	<a href="#">E05B 71/00</a>
Anti-theft arrangements for helmets	<a href="#">A42B 3/0413</a>
Devices for storing or displaying riffles or guns	<a href="#">A47B 81/005</a>
Show cases with theft protection	<a href="#">A47F 3/002</a>
Anti-theft means for display panels	<a href="#">A47F 5/0861</a>
Show stands with provision for preventing unauthorised removal	<a href="#">A47F 7/024</a>
Anti-theft devices for skis or ski equipment	<a href="#">A63C 11/004</a>
Covers cups or guards for traction coupling, hitches	<a href="#">B60D 1/60</a>
Supporting devices for attaching articles to cycles	<a href="#">B62J 11/00</a>

#### Application-oriented references

*Examples of places where the subject matter of this place is covered when specially adapted, used for a particular purpose, or incorporated in a larger system:*

Walking sticks with locks	<a href="#">A45B 1/04</a>
Umbrella stands or holders	<a href="#">A47G 25/12</a>
Cases for storing record carrier discs	<a href="#">G11B 33/0405</a>

#### Informative references

*Attention is drawn to the following places, which may be of interest for search:*

Chain or cable locks	<a href="#">E05B 67/003</a>
Lockable hangers or hanger racks	<a href="#">E05B 69/006</a>

Hasp fastenings	<a href="#">E05C 19/08</a>
-----------------	----------------------------

## E05B 73/02

for walking-sticks or umbrellas {(locks integral with walking sticks [A45B 1/04](#))}

### References

#### Limiting references

*This place does not cover:*

Locks integral with walking sticks	<a href="#">A45B 1/04</a>
------------------------------------	---------------------------

#### Informative references

*Attention is drawn to the following places, which may be of interest for search:*

Stick or umbrella holders in general	<a href="#">A47G 25/12</a>
--------------------------------------	----------------------------

## E05B 75/00

Handcuffs {; Finger cuffs; Leg irons; Handcuff holsters; Means for locking prisoners in automobiles (retaining devices for the body or body parts [A61F 5/37](#))}

### Definition statement

*This place covers:*

Handcuffs; Finger cuffs; Leg irons; Handcuff holsters; Means for locking prisoners in automobiles

### References

#### Application-oriented references

*Examples of places where the subject matter of this place is covered when specially adapted, used for a particular purpose, or incorporated in a larger system:*

Restraining devices for body parts	<a href="#">A61F 5/37</a>
------------------------------------	---------------------------

## E05B 77/00

Vehicle locks characterised by special functions or purposes (locks specially adapted for bicycles [E05B 71/00](#); locking arrangements for non-fixed vehicle roofs [B60J 7/185](#))

### References

#### Limiting references

*This place does not cover:*

Locks specially adapted for bicycles	<a href="#">E05B 71/00</a>
Locking arrangements for nonfixed vehicle roofs	<a href="#">B60J 7/185</a>

## Glossary of terms

In this place, the following terms or expressions are used with the meaning indicated:

latching/unlatching	holding/release of a bolt element that a wing or door can be opened. A typical vehicle lock is unlatched when a detent, pawl or ratchet releases the fork shaped bolt
locking/unlocking	preventing/allowing an unlatching action. In the locked state an unlatching action, normally done by actuating a handle or grip, is prevented. A locked door or wing is at least prevented from being unlatched from outside of the vehicle

## E05B 77/02

### for accident situations

#### Definition statement

*This place covers:*

Locks designed to perform or prevent certain functions in case of accidents

## E05B 77/04

### Preventing unwanted lock actuation, e.g. unlatching, at the moment of collision

#### Definition statement

*This place covers:*

Locks, where an unwanted unlatching is prevented in case of an accident. One particular example is that a door handle could be accidentally actuated in case of a collision against the side door of a vehicle.

One way of preventing such an unwanted actuation is the provision of an extra long bowden cable. The extra length thereby prevents unwanted actuation, if a vehicle part is deformed.

The figure shows another construction, which should avoid actuation at the moment of a collision. Two parallel connecting rods (10, 11) are provided, such that if one of the rods (10,11) would be deformed during an accident, then it could not cause the lever (9) to turn since the second lever (11) would resist this by an equal force acting to turn the lever (9) in the opposite direction.

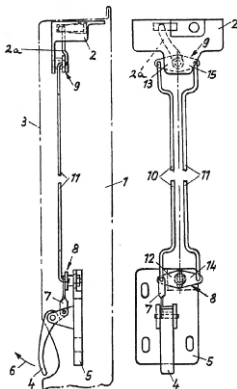

## E05B 77/06

by means of inertial forces

### Definition statement

*This place covers:*

Means for preventing actuation caused by inertial forces acting on lock parts in case of an accident. Typically, a weight arrangement is used, which is actuated in order to block a handle against movement at the moment of collision.

The figure shows an example whereby at the moment of a collision a force (29b) would cause a mass-lever (30) to rotate counterclockwise. A blocking member (34) of the mass-lever (30) thereby prevents the handle (37) to be actuated by an inertial force (32b).

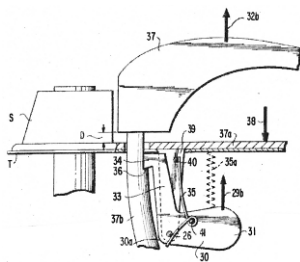

## E05B 77/08

Arrangements for protection of pedestrians

### Definition statement

*This place covers:*

Locks designed for pedestrian protection. In practice, it almost always concerns engine compartment locks ([E05B 83/24](#))

The example in the figure concerns an active front hood system, whereby both the hinge part (41) and the lock (25) are designed such that they are automatically raising the hood (13) in case of a collision with a pedestrian. This allows the front zone of the vehicle to deform easier.

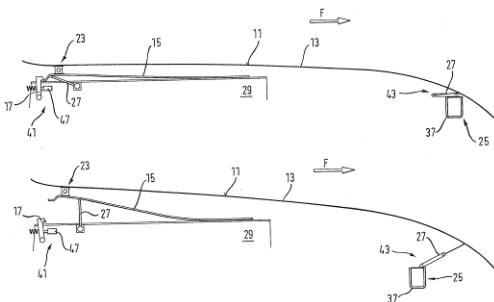

## References

### Informative references

Attention is drawn to the following places, which may be of interest for search:

Arrangements or fittings on vehicles for protecting non-occupants of a vehicle, e.g. pedestrians, in case of accidents	<a href="#">B60R 21/34</a>
--	----------------------------

## E05B 77/10

### Allowing opening in case of deformed bodywork, e.g. by preventing deformation of lock parts

#### Definition statement

*This place covers:*

The general problem that a wing/door is frequently deformed at an accident. In this subgroup the lock is protected in such a way that it can be unlatched/unlocked even if the door is deformed. This is often achieved by protective plates, shields and reinforcements.

Another alternative is to design lock parts in order to be deformed in a controlled way, such that they can still function after an accident. In the figure the bolt (8) and the detent (13) are provided with deformation zones (17, 25, 26). In case of an accident the bolt and the detent will not break. They will rather be deformed plastically such that they will still function properly after the collision.

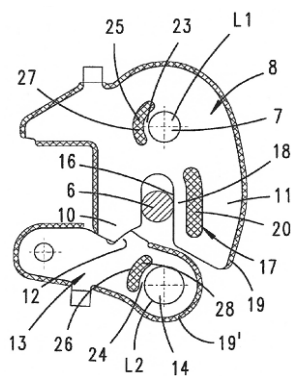

## E05B 77/12

### Automatic locking or unlocking at the moment of collision

#### Definition statement

*This place covers:*

Arrangements whereby a particular action is forced to take place in case of an accident. The situation is more or less the opposite of [E05B 77/04](#) in which a particular action is prevented.

A typical example is that a locking or an unlocking action is initiated at the accident. The choice of action depends on the security philosophy. Sometimes an unlocked door, which allows easy escape, is preferred and sometimes the preference is a locked door, which prevents (unwanted) opening of the door.

Another frequent example from this class is locks which after an accident remain locked for a certain time and then automatically move to an unlocked condition.

The example of the figure shows a system whereby a sensing means (50) is designed to pivot in case of an accident. This releases the bolt element (26) which is moved by a spring (52) into a striker (56). The door is therefore automatically locked at the moment of an accident.

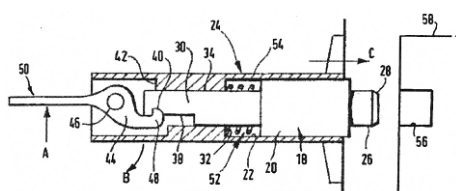



## E05B 77/14

**Specially controlled locking actions in case of open doors or in case of doors moved from an open to a closed position, e.g. lock-out prevention or self-cancelling**

### Definition statement

*This place covers:*

Locks which usually concern the problem that vehicle keys can be left inside the vehicle, if the door would be accidentally closed in a locked condition.

## E05B 77/16

**Preventing locking with the bolt in the unlatched position, i.e. when the door is open**

### Definition statement

*This place covers:*

Locks in which the bolt position is sensed e.g. mechanically, magnetically or electrically. An unlatched bolt should thereby indicate an open door, and in this situation the locking system is blocked in order to make it possible to lock the door only after it has been closed.

The example of the figure illustrates this by a detent (20) having a cam (46) and a locking lever (24) having a shoulder (48).

When the bolt (14) is in its open position, the locking lever (24) cannot move to the locked position, since the shoulder (48) of the locking lever (24) is blocked by the cam (46) on the detent.

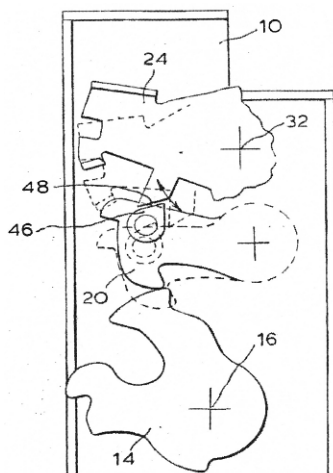

## E05B 77/18

**Keyless locking with self-cancellation, e.g. resulting in an unlocking action when the door is being closed**

### Definition statement

*This place covers:*

Locks where the closing of the door always results in an unlocking action. The lock will thus never be in a locked state after having closed the door. This means that the door can always be unlatched after closing.

## E05B 77/20

### Override of self-cancellation, e.g. by actuation of the handle while the door is being closed

#### Definition statement

*This place covers:*

Arrangements whereby the automatic unlocking action can be prevented by overriding means, which require an additional action by the user, e.g. that the door handle is actuated during the closing of the door.

The user can thus decide, that the door should remain locked after closing, but this choice requires that a certain action is carried out during the closing. This makes it less likely, that the door is by mistake closed in a locked state.

According to the exemplifying figures, a lever (60) is actuated by a handle and can be used for unlatching the lock, if a release lever (64) can hit a pin (42) on the detent.

A locking lever (66) can move the release lever (64) to a locked position in which it will not hit the pin (42) as shown in the lower figure. A cam element (92a, 92b) rotates together with the actual latch bolt.

If the lock is brought to the locked position when the door and thereby also the bolt are in the open position, then the closing of the door will rotate the bolt to the latched position. The cam (92b) will therefore act on an intermediate element (94), which brings the locking lever (66) back to the unlocked position.

If however the handle lever (60) is actuated during the closing of the door, then the cam (92b) will not be able to contact the intermediate element (94) as shown in the right-hand figure. The lock will thereby stay in the locked position.

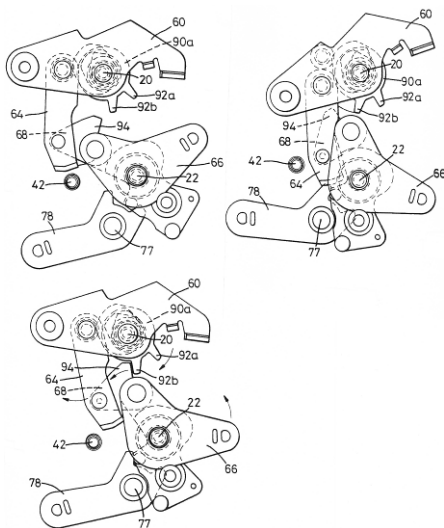

## E05B 77/22

### Functions related to actuation of locks from the passenger compartment of the vehicle

#### Definition statement

*This place covers:*

Certain functions linked to the inside actuation of locks.

## References

### Informative references

Attention is drawn to the following places, which may be of interest for search:

Sill-buttons, garnish buttons or inside door lock knobs	<a href="#">E05B 85/08</a>
Inner door handles	<a href="#">E05B 85/12</a>

## Special rules of classification

Constructional details of the inside actuation means, e.g. inner door handles, sill buttons or lock knobs, are classified in group [E05B 85/08](#) and [E05B 85/12](#).

## E05B 77/24

### preventing use of an inner door handle, sill button, lock knob or the like

#### Definition statement

*This place covers:*

Essentially the subjects "child safety" and "super-locking/double-locking". Even though the general purpose of preventing an inside handle from being used is the same for these both functions, there is one fundamental difference.

Child safety prevents the use of an inside handle at any time, i.e. the inside handle can never be used regardless if the door is unlocked or locked from the outside. A double-locked/super-locked door has an inside handle, which cannot be used, when the door is locked from the outside.

## E05B 77/26

### pecially adapted for child safety

#### Definition statement

*This place covers:*

Locks which prevent all use of an inside handle, when the child safety is activated. This means that the inside handle cannot be used regardless if the door is unlocked or locked from the outside.

The figure shows a child safety arrangement with an actuation button (7) of the push-push type. Every time the button (7) is pushed, the system changes between an active and an inactive state.

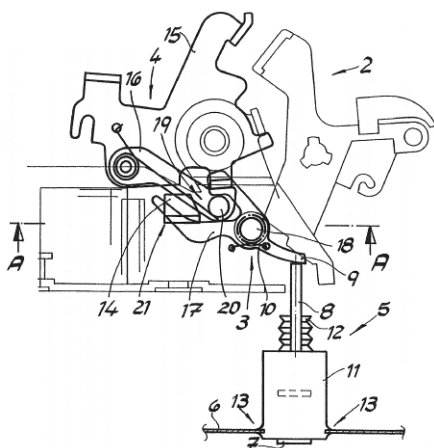

## E05B 77/28

for anti-theft purposes, e.g. double-locking or super-locking

### Definition statement

*This place covers:*

Locks having an inside handle, which cannot be used, when the door is locked from the outside. It is therefore not possible to open the door by breaking a window in order to reach the inside handle.

The double-locking can be achieved either by uncoupling or blocking of the inside lock system and inside handle.

In the figure, an example of a blocking system is shown. A double-lock arrangement (9, 12) prevents any actuation of an inside lock knob rod (7).

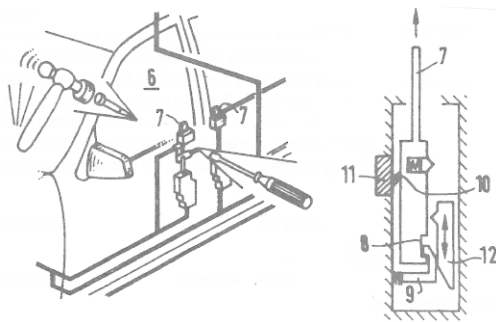

## E05B 77/30

allowing opening by means of an inner door handle, even if the door is locked

### Definition statement

*This place covers:*

A combined unlocking and unlatching function of the inside door handle. This is sometimes achieved by one single actuation of the handle. Another possibility is that a first actuation of the handle unlocks the door and that the second actuation unlatches the door.

The figure shows an example of an inside handle (7), which can be moved from a neutral position (A) to an unlatching position (B). If the door would be locked, then the same handle can be moved from the neutral position (A) to an intermediate position (C) and back to the neutral position (A) in order to unlock the lock. The handle can thereafter be actuated one more time to position (C) for unlatching.

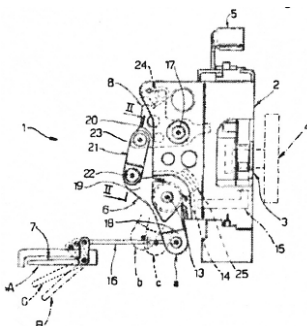

## E05B 77/32

allowing simultaneous actuation of locking or unlocking elements and a handle, e.g. preventing interference between an unlocking and an unlatching action

### Definition statement

*This place covers:*

Arrangements addressing the well known problem that an unlocking (or locking) action can fail, if the handle of the door is actuated at the same time.

Often a second unlocking action is required. This problem is normally avoided by an energy accumulation arrangement of springs.

## E05B 77/34

Protection against weather or dirt, e.g. against water ingress (closures or guards for keyholes [E05B 17/14](#))

### Definition statement

*This place covers:*

Means offering protection against weather influence. This can for example be achieved by a totally closed lock housing or by arranging some parts of the lock in a "wet compartment" and other parts in a "dry compartment". Another type of weather protection concerns means preventing freezing of the lock in cold conditions.

In the figure, a "wet area" (N) of the lock comprises the main lock elements, i.e. the bolt (3a) and the detent (3b). A sensing arrangement (7a, 7b) for determination of the detent position is housed in a "dry area" (T) of the lock. A single thin link rod (50) extends from the "wet area" to the "dry area" through a small opening (80).

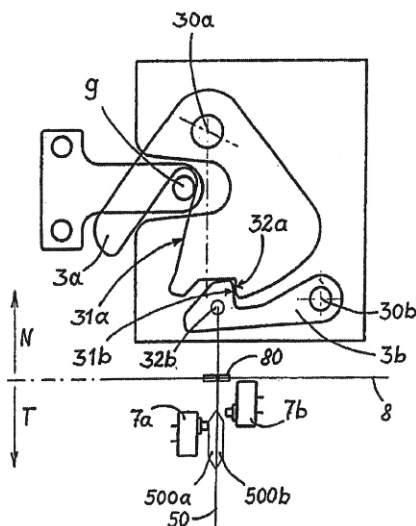

### References

#### Limiting references

*This place does not cover:*

Closures or guards for keyholes	<a href="#">E05B 17/14</a>
---------------------------------	----------------------------

## E05B 77/36

### Noise prevention; Anti-rattling means

#### Definition statement

*This place covers:*

Ways of reducing noise and vibrations in locks. The example in the figure shows a lever element (8) of a lock. The end positions of the lever are defined by stretching of cord elements (3, 3a). The use of cords for this purpose reduces the noise of the lever (8) reaching its end position.

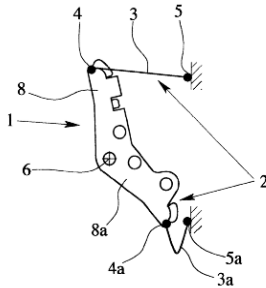

## E05B 77/38

### Cushion elements, elastic guiding elements or holding elements, e.g. for cushioning or damping the impact of the bolt against the striker during closing of the wing

#### Definition statement

*This place covers:*

Elastic blocks, elastic guiding elements etc. which are typically placed in the zone of engagement between the bolt and the striker. One function of such blocks can thus be to make an impact between moving elements softer.

Another purpose can be to hold for example a striker firmly fixed in the latched position. This prevents noise due to rattling.

In the figure, an elastic cushion means (30, 40) defines a seat for firmly holding the striker (2).

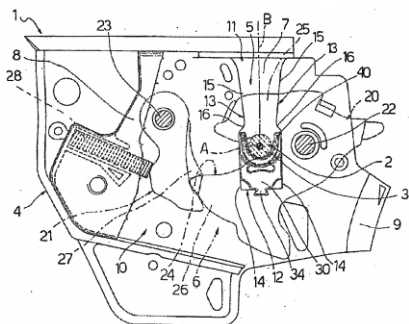

## E05B 77/40

### Lock elements covered by silencing layers, e.g. coatings

#### Definition statement

*This place covers:*

Bolts, strikers, detents etc. which are covered by a (thin) anti-noise coating/layer. One rather typical example is a metal bolt with a plastic coating.

According to the exemplifying figure, a coating (16) of elastically deformable material allows any direct contact between the base plate (2) of the striker and the bodywork of the vehicle. The noise produced during closing of the lock is thereby reduced.

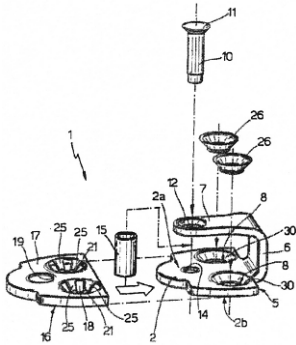

## E05B 77/42

### Means for damping the movement of lock parts, e.g. slowing down the return movement of a handle ([E05B 77/38](#) takes precedence)

#### Definition statement

*This place covers:*

Arrangements for damping of movements. This class does however not cover elastic blocks/guides ([E05B 77/38](#)). It is rather directed to dampers, for example of the fluid type. A typical example is a damper, which slows down the return movement of a handle.

The return movement of the handle in the figure is slowed down by a fluid damper (30).

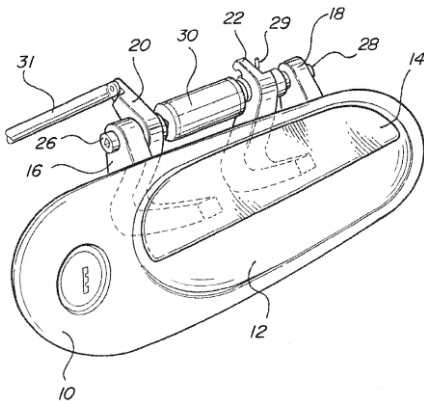

## E05B 77/44

### Burglar prevention, e.g. protecting against opening by unauthorised tools (E05B 77/28 takes precedence)

#### Definition statement

*This place covers:*

Locks where an arrangement has been provided, which prevents manipulation by burglar tools. Typical examples are protective shields, completely closed casings, or plates which deflect tools away from the essential lock parts.

The figure shows a hollow shield (34) which covers and protects the locking lever (14) and the linkage (20,24) between the locking lever (14) and the lock cylinder (30).

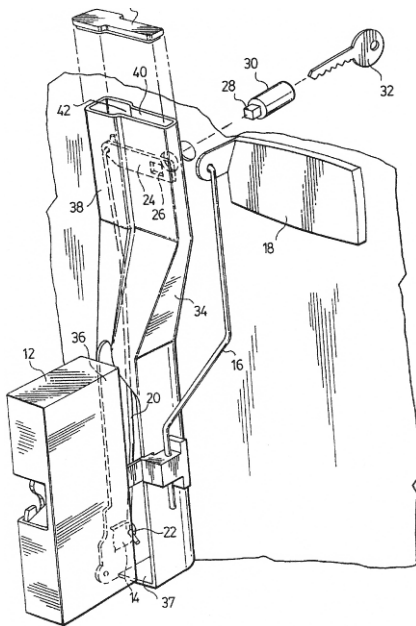

## E05B 77/46

### Locking several wings simultaneously

#### Definition statement

*This place covers:*

Central locking arrangements. The lower subgroups concern the main families of such arrangements, and the example in the figure therefore shows a more unusual central lock configuration.





## E05B 77/50

by pneumatic or hydraulic means

### Definition statement

*This place covers:*

Pneumatic or hydraulic circuits for control of several locks in a central locking system. This subgroup is essentially directed to the overall circuits, as exemplified by the figure wherein a number of actuators (1-4) is controlled by a central control system.

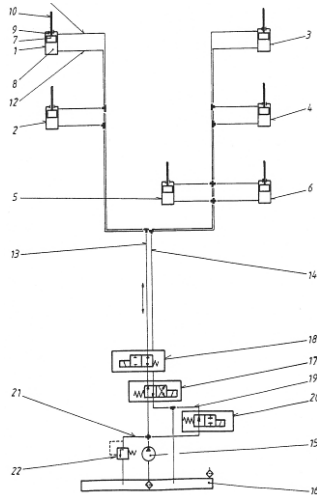

## E05B 77/52

Locking one wing by shutting another

### Definition statement

*This place covers:*

Sequential lock control of a vehicle door system. As shown in the figure, when a first door (A) is unlatched a second door (B) is unlocked, and when the first door (A) is closed and its bolt moves to a latched position, then the bolt of the second door (B) is automatically locked.

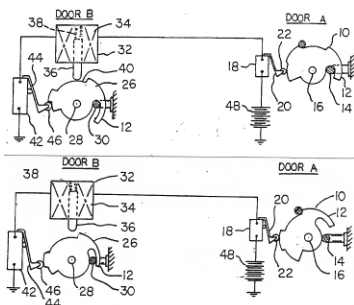

## References

### Informative references

*Attention is drawn to the following places, which may be of interest for search:*

Wings which abut when closed, whereby a fastening for one wing is actuated or controlled by closing the other wing	<a href="#">E05C 7/06</a>
--	---------------------------

## E05B 77/54

**Automatic securing or unlocking of bolts triggered by certain vehicle parameters, e.g. exceeding a speed threshold (triggered by vehicle collision [E05B 77/12](#))**

### Definition statement

*This place covers:*

Locking of vehicle doors, based on the state of the vehicle systems in general. The state of the door locks could thereby be decided based on for example the speed of the vehicle, the status of the ignition lock, the selected gear or the actuation of the vehicle brakes.

### References

#### Limiting references

*This place does not cover:*

Triggered by vehicle collision	<a href="#">E05B 77/12</a>
--------------------------------	----------------------------

## E05B 79/02

**Mounting of vehicle locks or parts thereof**

### Definition statement

*This place covers:*

Various aspects of the mounting of lock elements or mounting of the lock itself. It is to be noted, that this subgroup does not cover the connection of movable parts to each other ([E05B 79/10](#)).

## E05B 79/04

**Mounting of lock casings to the vehicle, e.g. to the wing**

### Definition statement

*This place covers:*

Ways of attaching the lock casing to the vehicle. The casing is thereby often mounted to the wing, but it may also concern the mounting of casings on the fixed frame.

Definition statement

According to the example of the figure, bolt elements (36) are used as axis for e.g. the bolt and the detent of the lock. At the same time these bolt elements (36) have threaded parts (50) which are used for mounting the lock casing (22) to the vehicle.

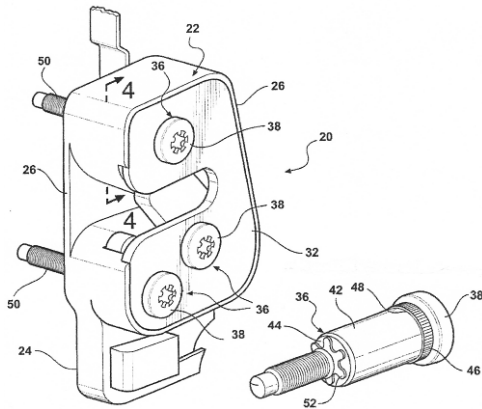

**E05B 79/06**

**Mounting of handles, e.g. to the wing or to the lock**

**Definition statement**

*This place covers:*

Ways of mounting the handles specific elements in the lock. The figure shows a system using two different screw arrangements (6, 7) for attaching the handle to the wing.

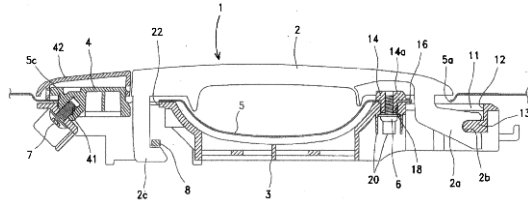

## E05B 79/08

### Mounting of individual lock elements in the lock, e.g. levers

#### Definition statement

*This place covers:*

Ways of mounting specific elements in the lock. According to the example in the figure, a specific type of pivot axis (32) is used for mounting the bolt (12) and the detent (14).

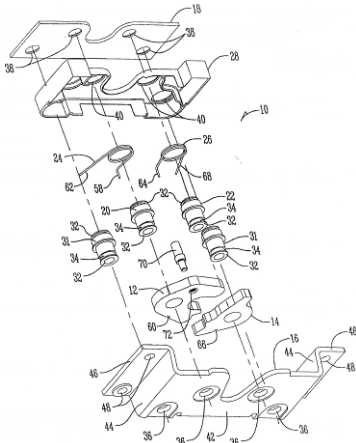

## E05B 79/10

### Connections between movable lock parts

#### Definition statement

*This place covers:*

Various ways of connecting movable lock parts to each other. The lower subgroups cover the most frequently represented connection aspects.

## E05B 79/12

### using connecting rods

#### Definition statement

*This place covers:*

Elongated connection elements. According to the example shown in the figure a connecting rod (2) is provided with an extension (3) having a hooked end (4). If the door and the rod would be deformed,

## Definition statement

e.g. due to a collision, then the hooked extension of the rod can cooperate with the edge of an opening (6) such that unwanted operation of the lock occurs.

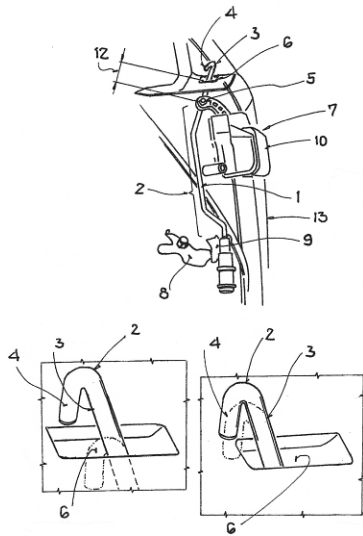
**E05B 79/14**

the rods being linked to each other

**Definition statement**

*This place covers:*

Ways of connecting rods to each other, as exemplified by a connecting element (40), which links two operating rods (31, 32) to each other.

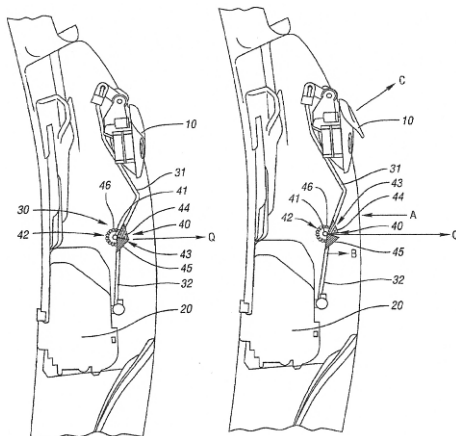
**E05B 79/16**

characterised by the means for linking the rods to other lock parts, e.g. to levers

**Definition statement**

*This place covers:*

Details of how connecting rods are fixed to other lock elements. This would usually be the connection to a handle element or to a lever element in the lock housing. It can also concern the details of how a rod is connected to the output member of a powered actuator.

## Definition statement

According to the example, a rod clip has one part (23), which is connected to a lever of the lock mechanism, while another part (22,32) connects to an operating rod (40).

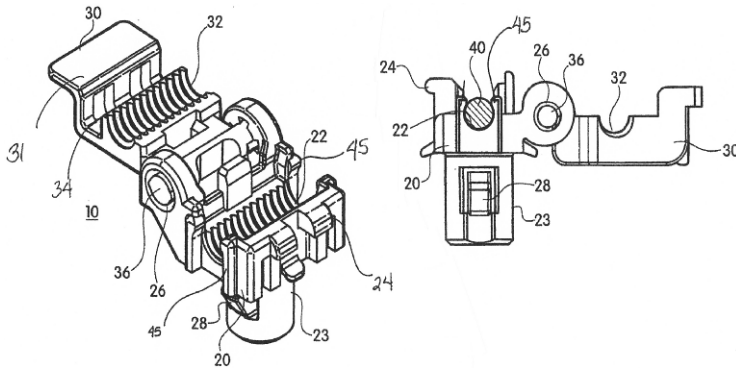
**E05B 79/18****Rod guides****Definition statement**

*This place covers:*

Means for guiding long rod elements. In the case of fairly long rod elements it might be necessary to provide guiding means along the length of the rod. This is of particular importance in order to prevent bending of the rod, when it is compressed during a pushing action.

A typical example of such a rod guide (7) is shown in the figure.

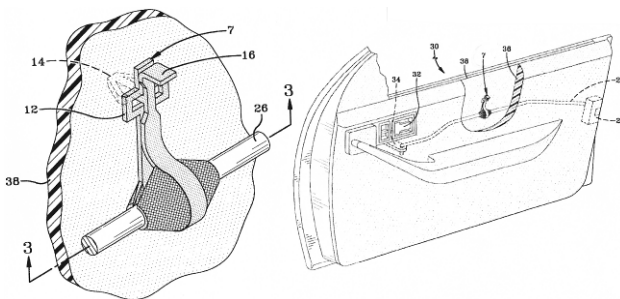
**E05B 79/20****using flexible connections, e.g. Bowden cables****Definition statement**

*This place covers:*

Non-rigid connections between lock parts. Bowden cables are frequently used in these situations, but also wires, ropes or the use of springs as connection means are covered by this subgroup.

## Definition statement

The figure shows a specific type of Bowden-cable connection, whereby a cable (32) is fixed at one end (36). Tensioning the cable (36) will therefore cause the sheath (12) to be straightened and thereby push on a lever (12) of the lock.

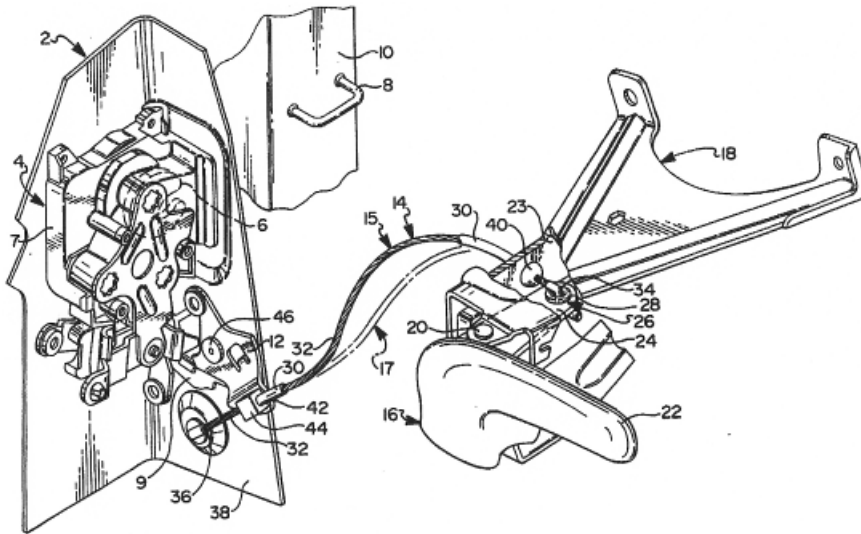

## References

**Informative references**

Attention is drawn to the following places, which may be of interest for search:

Flexible shafts; ... Mechanical means for transmitting movement in a flexible sheathing	<a href="#">F16C 1/00</a>
---	---------------------------

**E05B 79/22**

**Operative connections between handles, sill buttons or lock knobs and the lock unit (mounting of non-movable base elements of a handle to a lock [E05B 79/06](#))**

**Definition statement**

*This place covers:*

Details of how hand actuated elements are connected to lock elements. It is to be noted that [E05B 79/12](#) and [E05B 79/20](#) quite often will cover the connection of handles to a lock situated at a distance more or less far away.

This subgroup will consequently for example cover operative, i.e. movable, connections where a handle is more or less directly fixed to the lock. Other elongated connections than rods or flexible elements will also be covered by this subgroup.

## References

**Limiting references**

*This place does not cover:*

Mounting of the non-movable base elements of a handle to a lock	<a href="#">E05B 79/06</a>
---	----------------------------



## E05B 81/00

### Power-actuated vehicle locks

#### Glossary of terms

In this place, the following terms or expressions are used with the meaning indicated:

latching/unlatching	holding/release of a bolt element that a wing or door can be opened. A typical vehicle lock is unlatched when a detent, pawl or ratchet releases the fork shaped bolt
locking/unlocking	preventing/allowing an unlatching action. In the locked state an unlatching action, normally done by actuating a handle or grip, is prevented. A locked door or wing is at least prevented from being unlatched from outside of the vehicle

## E05B 81/02

### characterised by the type of actuators used

#### Definition statement

This place covers:

Various types of actuators, whereby the most common alternatives are covered by the lower subgroups.

One example of a less common power driving means is shown in the figure, which shows a pyrotechnic charge (10) provided for bringing a bolt (4) or a connecting rod (24) to an unlocked position in case of an accident.

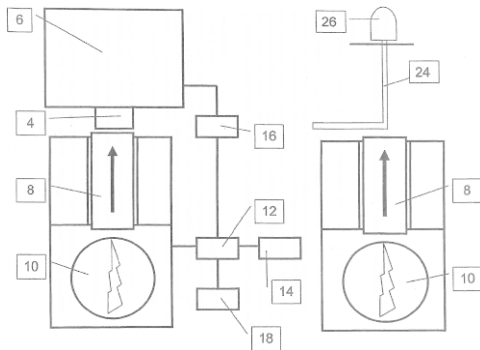

## E05B 81/04

### Electrical (electrical circuits [E05B 81/54](#))

#### Definition statement

This place covers:

Actuators driven by electricity. The figure shows a lock with a handle (3), which can release a bolt (2) from a striker (6). The bolt (2) can also be released by electrically heating a shape memory alloy

Definition statement

actuator wire (9). This heating shrinks the actuator wire, and the bolt (2) will consequently be released from the striker (6).

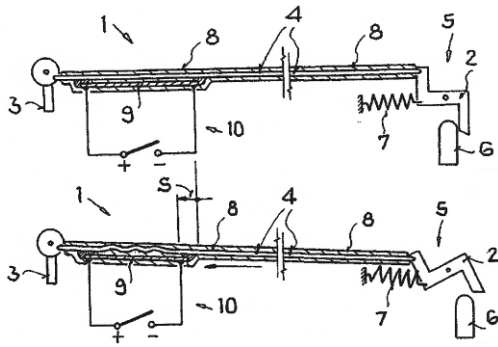

**References**

**Limiting references**

*This place does not cover:*

Electrical circuits	<a href="#">E05B 81/54</a>
---------------------	----------------------------

**E05B 81/06**

using rotary motors

**Definition statement**

*This place covers:*

Electrically driven motors, as exemplified by the motor (2) of the figure.

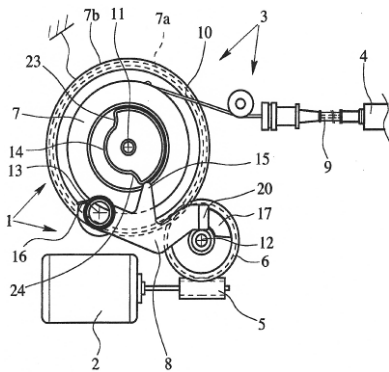



## E05B 81/12

characterised by the function or purpose of the powered actuators

### Definition statement

*This place covers:*

Various ways of using an actuator in a vehicle lock. These uses are thereby in principal defined depending on which lock part(s) the actuator is connected to.

## E05B 81/14

operating on bolt detents, e.g. for unlatching the bolt

### Definition statement

*This place covers:*

A typical vehicle lock comprises a fork-shaped rotary latch bolt, which is kept in its latched position by a detent. In this subgroup the power actuator releases the detent of the bolt and consequently an unlatching takes place. The result of the powered actuation is thus that the door is free to be opened.

The figure shows an actuator (12), which drives cam elements (17) through a geared transmission. The cam elements (17) act on a detent (2) in order to unlatch the bolt (1).

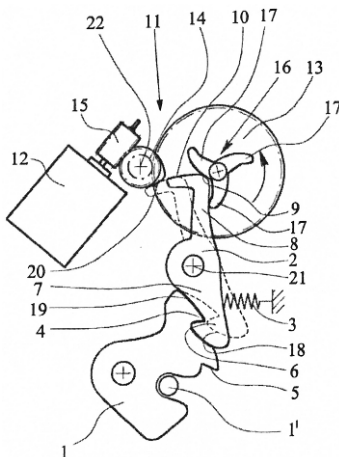

## E05B 81/16

operating on locking elements for locking or unlocking action

### Definition statement

*This place covers:*

Actuators which achieve the movement of a locking element (typically a locking lever) between a locked and an unlocked position.

The actuator consequently moves the lock between an unlocked state wherein the bolt is allowed to move and a locked state in which the movement of the bolt is prevented.

The movement of the bolt is thus not directly influenced by the actuator. A very common example in this subgroup is the powered locking/unlocking of central-locking arrangements.

## Definition statement

According to the figure, a locking lever (10) is pivotally mounted on the output axis (12) of an actuator (14). The locking lever (10) can be moved between a locked and an unlocked position by means of the actuator (14).

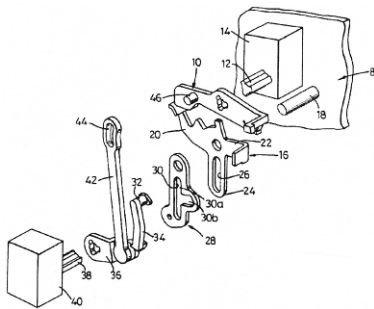

## E05B 81/18

to effect movement of a bolt or bolts ([E05B 81/20](#) takes precedence)

## Definition statement

*This place covers:*

Actuator acting on the bolt in order to move it, normally from a position in which it holds the door closed to a position in which the door can be opened, or vice-versa. It could thereby concern both latch bolts and dead bolts.

The figure shows an actuator (108), which drives a lock bolt (124) between a locked and unlocked position.

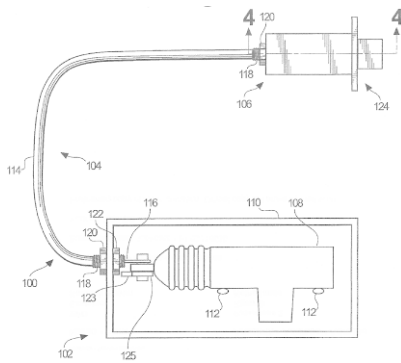

## References

## Informative references

Attention is drawn to the following places, which may be of interest for search:

Adaptation of locks, latches, or parts thereof, for movement of the bolt by electromagnetic means
---

<a href="#">E05B 47/02</a>
----------------------------

## E05B 81/20

for assisting final closing or for initiating opening

### Definition statement

*This place covers:*

Pulling the door tight or pushing the door slightly open. It is to be noted, that this subgroup covers the cases where these (small) movements of the door are achieved by the lock. This should not be confused with the powered closing /opening of for example [E05F 15/00](#), where the wing is moved from a (more or less) open position to a (more or less) closed position.

The example illustrates this by an actuator (21), which uses a pushing element (22) in order to assist movement of a bolt from a half-latched to a fully-latched position.

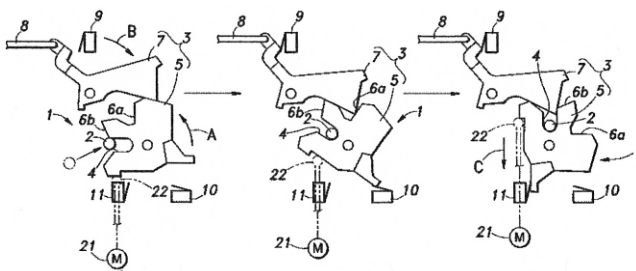

## E05B 81/22

by movement of the striker

### Definition statement

*This place covers:*

A movable striker for achieving the final closing or the initiated opening. A typical example is that after a first engagement between a striker and a bolt, the striker is moved by an actuator in order to further pull the wing tight.

The exemplifying figure shows an actuator in the form of an electric motor (8). When an axis (9) is turned by the motor (8), a pin (6) moves in an inclined slot (5) of a striker base (2). The actual striker (3) can thereby be driven by the motor (8) for assisting the movement of the door to a fully closed position.

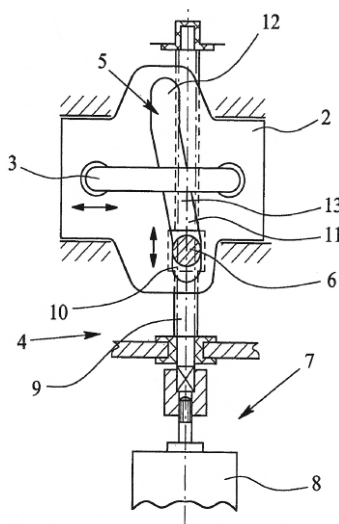

## E05B 81/24

**characterised by constructional features of the actuator or the power transmission**

### Definition statement

*This place covers:*

Various individual aspects of actuator details and transmission constructions.

## E05B 81/26

**Output elements**

### Definition statement

*This place covers:*

Different types of actuator output elements. It thereby essentially concerns the final element in the kinematic chain of the actuator device. Such an output element is then typically connected to elements of a vehicle lock, either directly or via further connecting means. The lower subgroups [E05B 81/28](#) and [E05B 81/30](#) relate to the two most common types of output members.

## E05B 81/28

**Linearly reciprocating elements**

### Definition statement

*This place covers:*

Output elements which move linearly, as exemplified by the sliding output member (105) in the figure.

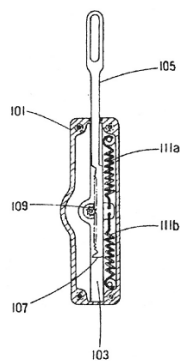

## E05B 81/30

### Rotary elements

#### Definition statement

*This place covers:*

Output elements which rotate, as exemplified by rotatable output members (10,12) which both rotate around axis (13) in the figure.

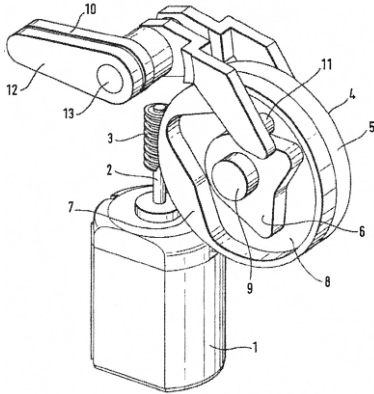

## E05B 81/32

### Details of the actuator transmission

#### Definition statement

*This place covers:*

Various elements in the kinematic chain before the actuator output member. Different typical kinematic elements are the subject of the lower subgroups [E05B 81/34](#) – [E05B 81/46](#).

## E05B 81/34

### of geared transmissions

#### Definition statement

*This place covers:*

Geared elements in the kinematic chain of the actuator, as exemplified by the toothed gear elements (8) which are driven by the worm-screw (19).

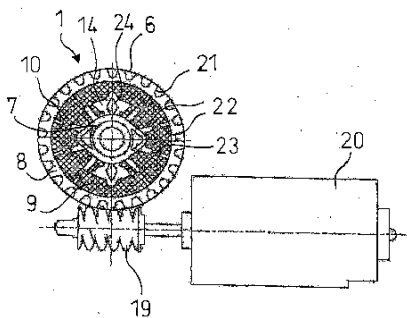



**E05B 81/36****Geared sectors, e.g. fan-shaped gears****Definition statement**

*This place covers:*

Elements in the shape of a sector with gears on its outer rim. An example of such a sector (10) is shown in the figure.

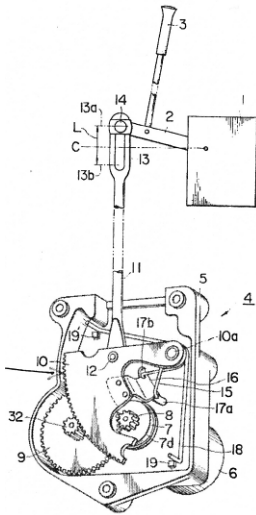
**E05B 81/38****Planetary gears****Definition statement**

*This place covers:*

The use of planetary gear transmission in actuators, as exemplified by the figure.

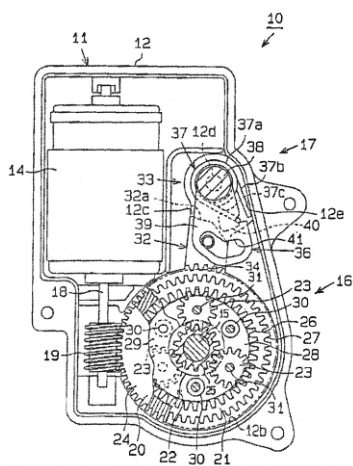

## E05B 81/40

### Nuts or nut-like elements moving along a driven threaded axle

#### Definition statement

*This place covers:*

Transmissions of the type where a nut-like element (6) slides along a threaded rotating axle (4) as exemplified by the figure.

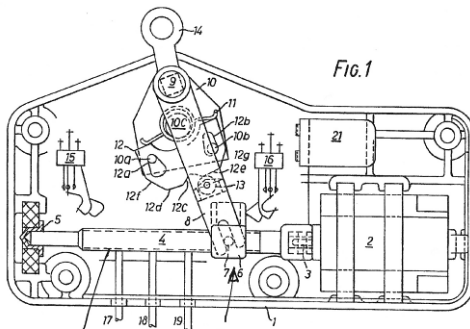

## E05B 81/42

### Cams

#### Definition statement

*This place covers:*

Cam-like transmission elements, for example a motor driven cam (34), which is used for transmitting a movement to elements of the actual lock.

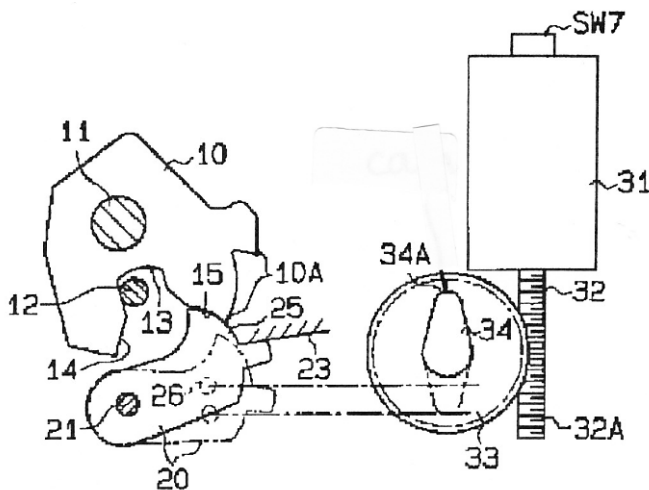

**E05B 81/44****in the form of grooves****Definition statement**

*This place covers:*

The use of the contour of a groove as cam element for transmission of a movement, as exemplified by the groove (3) in the figure.

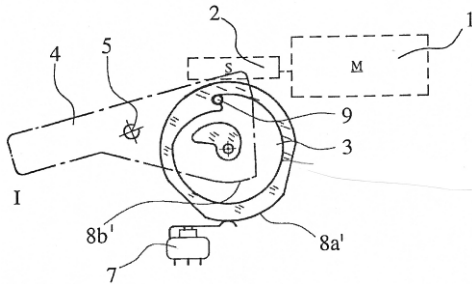
**E05B 81/46****Clutches****Definition statement**

*This place covers:*

Transmissions comprising some kind of engagable/releasable clutch arrangement. In the figure, a clutch element (23) engages a groove (21) in a driven element (13), when a motor driven element (9) starts rotating.

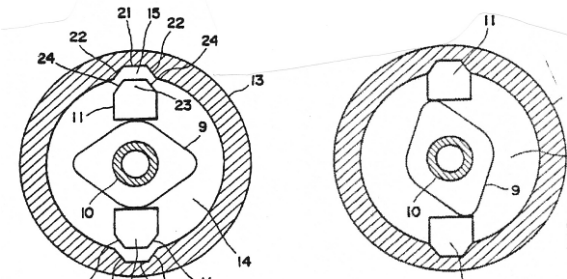
**E05B 81/48****Actuators being driven in a single direction****Definition statement**

*This place covers:*

Actuators moving only in one direction. From a starting position, the actuator moves continuously in one step or in several steps, always in the same direction, until it arrives back at the starting position again.

One example can be seen in the figure, where the motor (2) and the actuating element (8) can only turn in one direction (3,9). An electric arrangement (17) is provided for minimizing the back-drive when the drive pin (10) hits an abutment stop (12). When the detent pawl (11) has moved further clock-wise, then the actuator can continue to move in its single driving direction (3,9).

## Definition statement

It is to be noted, that essentially the whole movement cycle should be power actuated. If for example a significant part of the movement is achieved by e.g. a mechanical spring, then the subgroup [E05B 81/50](#) takes precedence.

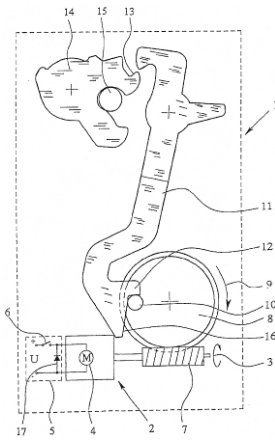
**E05B 81/50****Powered actuators with automatic return to the neutral position by non-powered means, e.g. by springs****Definition statement**

*This place covers:*

Actuators which are power driven to move from a neutral position to an active position, and the return movement to the neutral position is provided by non-powered means.

Examples of such arrangements can for example be a linearly moving solenoid, whereby an output member is moved electro-magnetically from a neutral position to an active position. When the power later is cut, a spring is arranged for moving the output member.

In the figure a geared transmission is moved by powered means to an active position. At the same time a geared rack (130) is moved, and this compresses spring (146). When the power is cut, the accumulated energy of the compressed spring (146) moves the rack (130) in the opposite direction such that the actuator returns to its normal position.

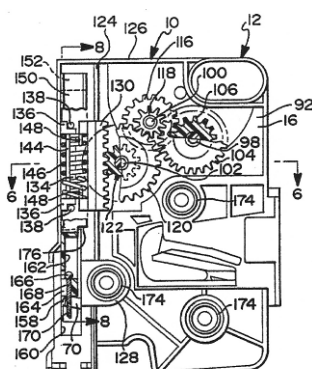

FIG 5

## E05B 81/52

### Pneumatic or hydraulic circuits (for locking several wings simultaneously [E05B 77/50](#))

#### Definition statement

*This place covers:*

Hydraulic or pneumatic circuits of vehicle locks. This subgroup concerns the overall circuits (pipes, valves pumps etc.) providing pressurized fluid to the actuators, while the structural elements of hydraulic/pneumatic actuators can be found in [E05B 81/10](#).

In the figure a typical example of a circuit in the sense of the present subgroup can be seen.

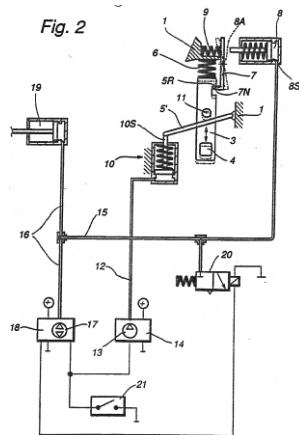

#### References

##### Limiting references

*This place does not cover:*

For locking several wings simultaneously	<a href="#">E05B 77/50</a>
--	----------------------------

## E05B 81/54

### Electrical circuits (for locking several wings simultaneously [E05B 77/48](#))

#### Definition statement

*This place covers:*

Electric circuit schemes and individual circuit components. The lower subgroups concern a variety of specific control methods, monitoring, sensing and energy supply. This subgroup will consequently contain e.g. electrical circuits not covered by the various lower subgroups.

#### References

##### Limiting references

*This place does not cover:*

Electric circuits for controlling plurality of locks on different doors	<a href="#">E05B 77/48</a>
---	----------------------------

## E05B 81/56

### Control of actuators

#### Definition statement

*This place covers:*

Various ways of controlling the way in which an actuator works. The most common control methods can be found in the respective lower subgroup. This means, that this subgroup will for example contain electrical circuits in cases which are not covered by one of the specific lower subgroups. An example of such a circuit is given in the figure, whereby an electrical control circuit (6) is provided in order to control the power input to the motor connectors (9,10).

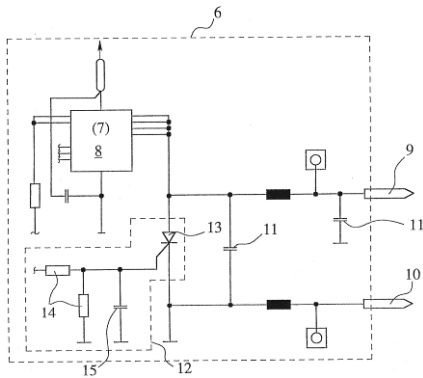

## E05B 81/58

### including time control, e.g. for controlling run-time of electric motors

#### Definition statement

*This place covers:*

The use of time data for the control of actuators. In the example of the figure, a switch indicates when 50% of the actuator stroke has been completed. The time needed for this first half of the stroke is measured and used in order to calculate how much run-time will be needed for achieving the second half of the stroke.

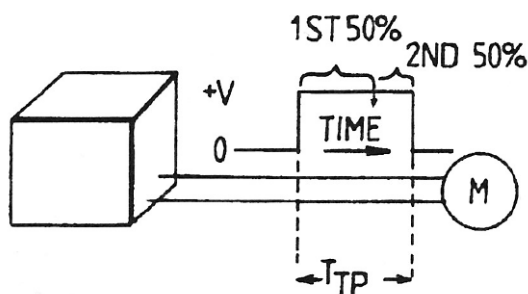

## E05B 81/60

### using pulse control, e.g. pulse-width modulation

#### Definition statement

*This place covers:*

Control of actuators by pulses e.g. of varying length and frequency. One way of providing such control is shown in the figure, whereby the pulse-width for operating the actuator to release the detent (4)

## Definition statement

from the bolt (1) is different from the pulse-width used for bringing the detent (4) back to the initial position.

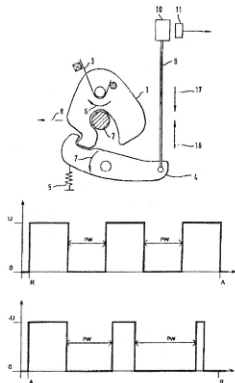

## E05B 81/62

for opening or closing of a circuit depending on electrical parameters, e.g. increase of motor current

## Definition statement

*This place covers:*

The use of electrical parameters for actuator control. A typical example of such a controlling method is to detect an increase of the current when an end position is reached, as exemplified by the figure wherein a current increase (124) is detected for stopping the movement of an actuator in one direction and a subsequent current increase (134) causes the stopping of the movement in the opposite direction.

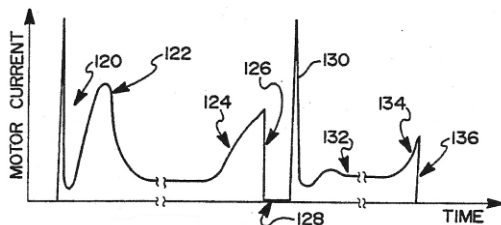

## E05B 81/64

Monitoring or sensing, e.g. by using switches or sensors

## Definition statement

*This place covers:*

Detection of lock states or user input by sensing/monitoring positions of various lock elements.

## E05B 81/66

the bolt position, i.e. the latching status

### Definition statement

*This place covers:*

Monitoring of the lock status by sensing the bolt position. In the exemplifying figure two switches (55,57) are used for indicating the position of the bolt (17).

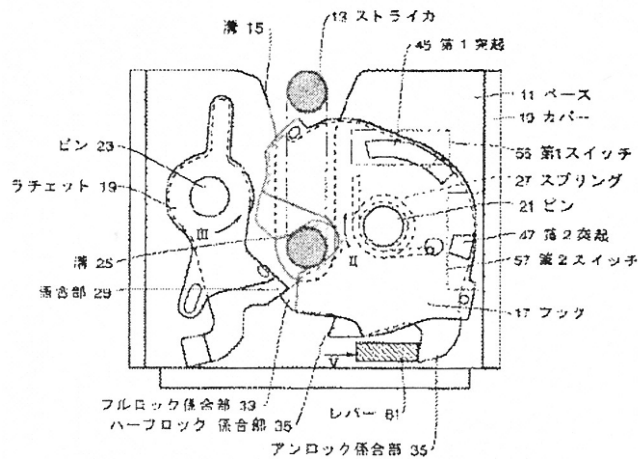

## E05B 81/68

by sensing the position of the detent

### Definition statement

*This place covers:*

Control of the lock status by sensing the detent position. In the figure, a sensor (10) detects the position of the bolt as well as the position of the detent.

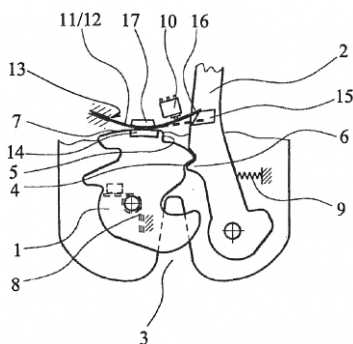



## E05B 81/70

### the wing position

#### Definition statement

*This place covers:*

Indication of the closure status by sensing the door position. It should be noted, that the sensors for door position should be part of the lock or at least related to the function of the lock. An example of a lock monitoring system, which uses the detection of the door position is shown in the figure.

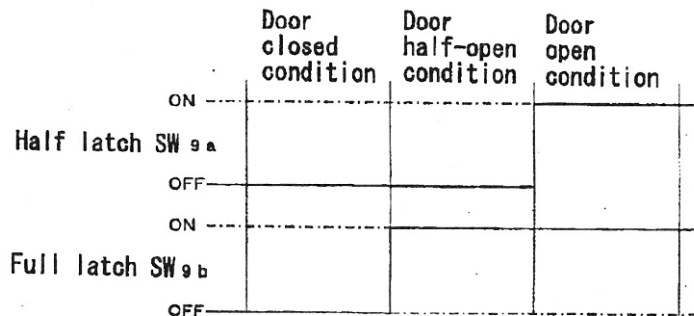

## E05B 81/72

### the lock status, i.e. locked or unlocked condition

#### Definition statement

*This place covers:*

Lock monitoring by sensing a locked/unlocked condition. In the figure, such a monitoring is performed by a switch (7).

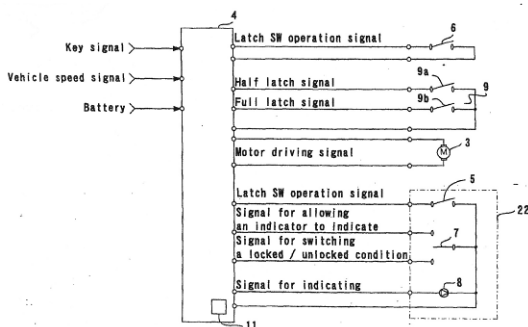

## E05B 81/74

### by sensing the state of the actuator

#### Definition statement

*This place covers:*

A special case of sensing the lock status via the state of the actuator. The figure shows such an arrangement, whereby a protrusion (32) comes into contact either of the two plates (36,38). This

## Definition statement

closes an electrical circuit, which indicates the state of the actuator and this is then used for indication of the lock status.

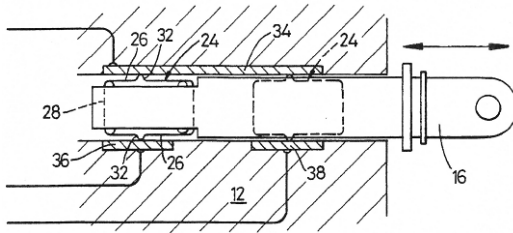
**E05B 81/76**

**Detection of handle operation; Detection of a user approaching a handle; Electrical switching actions performed by door handles**

**Definition statement**

*This place covers:*

Handles with some kind of electrical function. It first of all concerns handles working more or less as an electrical switch. The handle does thus not perform any mechanical action on the lock. It is simply a switch for sending a signal (e.g. by closing a circuit) to the lock-electronics.

This subgroup also covers handles, which perform both a mechanical function as well as an electric function.

An example of a switch-type handle is given in the figure. This shows an opening switch for vehicle doors or trunks, which is actuated by pressing the cover element (3) in the direction of the arrow.

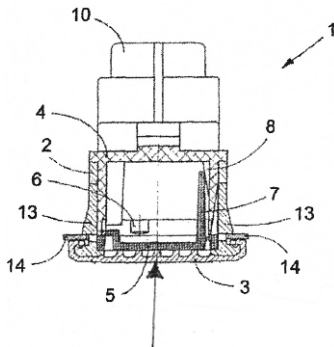
**E05B 81/78**

**as part of a hands-free locking or unlocking operation**

**Definition statement**

*This place covers:*

Handles used for the initiation of a hands-free opening. A sensor or switch in or near the handle starts the data transfer. This could be done either by moving the handle in a predetermined way or by a proximity sensor, which registers the approach of a hand towards the handle.

It should be noted that this class does not concern the details of the coded data transmission between the lock and a transponder key.

Definition statement

According to the example in the figure, two switches (28,29) can be sensed/actuated by different actions of a user's hand for example in order initiate a hands-free opening process.

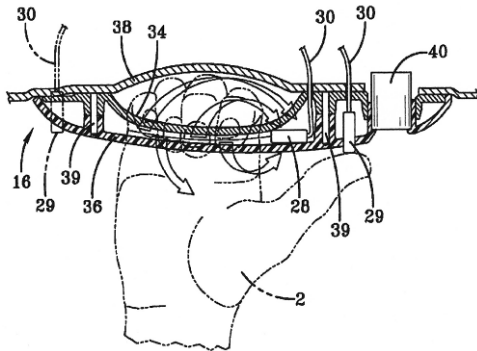

## E05B 81/80

**characterised by the power supply; Emergency power operation**

### Definition statement

*This place covers:*

Various kinds of energy sources (other than the vehicle main battery) and spare-power devices.

If the main power source is defect (for example because the main battery of the vehicle is empty), then these power sources can provide a small amount of power for an emergency opening of the vehicle. This section also covers cases where the primary energy source is not the vehicle main battery. This would for example sometimes be the case for certain types of battery charged locks.

## E05B 81/82

**using batteries other than the vehicle main battery**

### Definition statement

*This place covers:*

Additional batteries or back up batteries used for example in case of failure of energy supply from vehicle main battery.

## E05B 81/84

**using manually operated generator means**

### Definition statement

*This place covers:*

Generators operated by the vehicle user. Such generators can be adapted for supply of energy for example by handle movement, opening/closing of the door or introduction of the key into the keyhole.

## Definition statement

The figure shows a generator (22), which supplies energy for the operation of the actuator (17) when the voltage of the main battery is below a certain level.

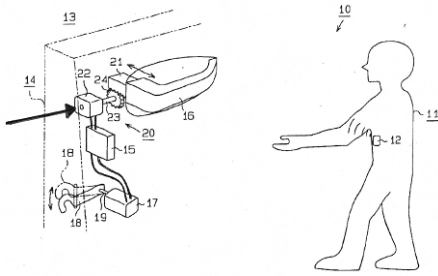
**E05B 81/86****using capacitors****Definition statement**

*This place covers:*

The use of capacitors for provision of energy for example when the main battery has been discharged. The figure shows a number of supercapacitors (30) which are available as a back-up energy source. A diode (32) or similar component prevents discharge of the supercapacitors (30) into the main power supply means.

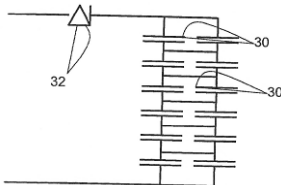
**E05B 81/88****using inductive energy transmission****Definition statement**

*This place covers:*

The use of induction for provision of energy. This can be used in situations when it is desired to avoid cables and contacts. One example of this type of arrangement is the provision of a coil in the key another coil in the lock for non-contact supply of emergency power to the lock.

**E05B 81/90****Manual override in case of power failure****Definition statement**

*This place covers:*

Purely mechanical manual override means. One example would be a door handle, which in normal use electrically activates an actuator. In case of a power failure this handle can be actuated further or in another direction in order to actuate the lock mechanically.

This subgroup also covers cylinder locks in normally not visible, concealed positions. In the figure, a cylinder lock (9) is for example mounted behind the rear-view mirror (1).

## Definition statement

It is to be noted, that this subgroup does not cover normally visible, non concealed cylinder locks mounted in or near the door handle.

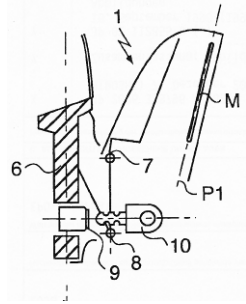
**E05B 83/00**

Vehicle locks specially adapted for particular types of wing or vehicle (locks specially adapted for bicycles [E05B 71/00](#); locking arrangements for non-fixed vehicle roofs [B60J 7/185](#); latching means for sideboards or tailgates of open load compartments [B62D 33/037](#))

**References****Limiting references**

*This place does not cover:*

Locks specially adapted for bicycles	<a href="#">E05B 71/00</a>
Locking arrangements for non-fixed roofs	<a href="#">B60J 7/185</a>
Latching means for sideboards or tailgates of open load compartments	<a href="#">B62D 33/037</a>

**E05B 83/02**

**Locks for railway freight-cars, freight containers or the like; Locks for the cargo compartments of commercial lorries, trucks or vans**

**Definition statement**

*This place covers:*

Locks for commercially used vehicles.

One specific subject, covered by this and the lower subgroups, is locks for (standardized) freight containers for use on trucks and trains, but also on ships or in aircrafts.

This subgroup consequently covers locks both for load compartments that form an integral part of the vehicle as well as freight containers forming a removable part which can be separated from the vehicle.

The figure shows a lockable structure applied to a container (1). In the locked position three bars (7, 8, 9) form a cross-bar construction preventing the doors (4, 5) of the container (1) to be opened.

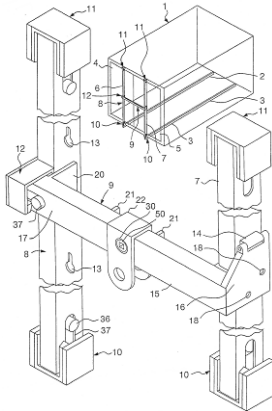

**E05B 83/04**  
**for sliding wings**

**Definition statement**

*This place covers:*

Locks for sliding wings on commercially used vehicles. The figure shows an example of a hook bolt (34) for locking a sliding roll-up door (16).

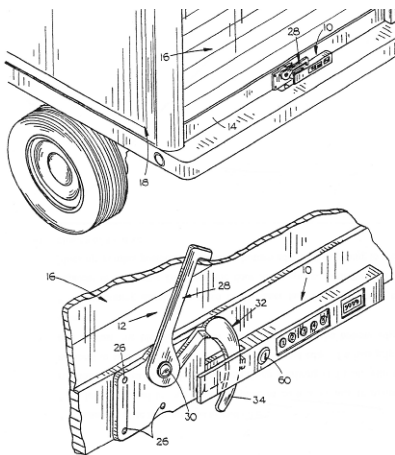

**E05B 83/06****of railway freight-cars****Definition statement**

*This place covers:*

Locking arrangements for railway freight cars, as exemplified by the figure where the locking device (20) keeps the sliding door (12) closed.

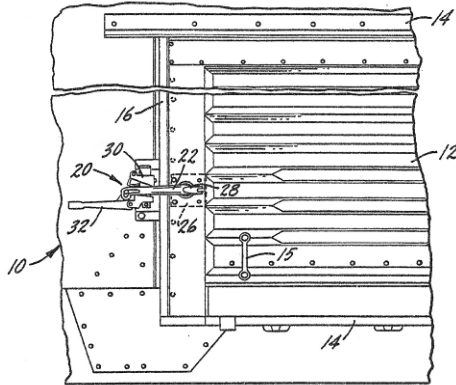
**E05B 83/08****with elongated bars for actuating the fastening means****Definition statement**

*This place covers:*

Locking devices with actuation bars which usually connect actuation means, for example a handle, with a fastening means. The figure illustrates this by showing a central actuation unit (10) connected to fastening means (22) by sliding bars (16).

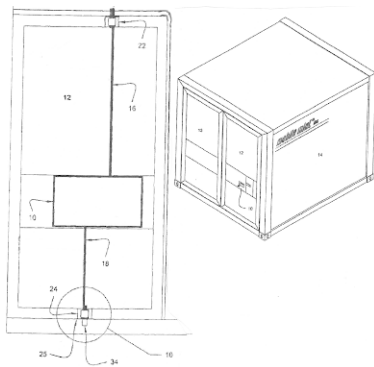
**E05B 83/10****Rotary bars****Definition statement**

*This place covers:*

A very common locking arrangement for cargo vehicles with rotary bars connecting for example a handle and lock bolt(s).

Definition statement

In the figure the rotary bars (50a, 50b) are actuated by handles (64a, 64b) in order to move fastening means (66,68) between a locked and unlocked position.

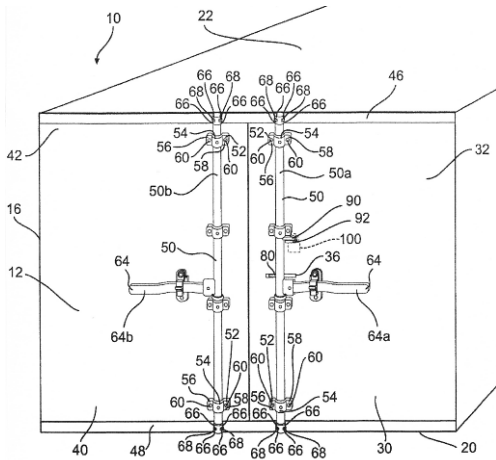

**E05B 83/12**

for back doors of vans ([E05B 83/04](#), [E05B 83/08](#) take precedence)

**Definition statement**

*This place covers:*

Smaller locks for vans (e.g. delivery vans, plumber's van, locksmith's van). These vans usually have doors with locks, which are similar to locks for passenger doors, but quite often adapted to the special requirements needed for the various commercial purposes of the van.

The example of the figure discloses a lock for use on a door between the driver compartment and the cargo compartment.

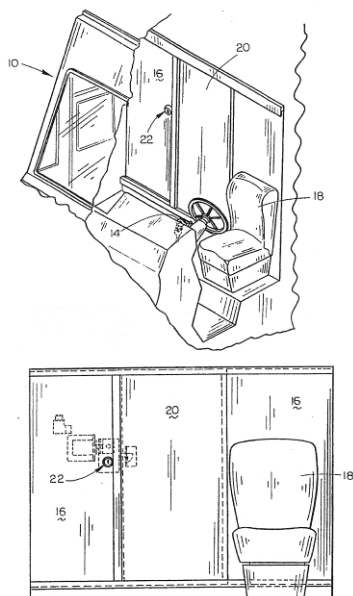



## E05B 83/14

with provisions for sealing

### Definition statement

*This place covers:*

Lock devices with means indicating authorized or unauthorized actuation of the lock device.

In the figure, the handle (143) of a hook bolt locking device is sealed by a wire (189) which has to be broken when the handle is to be actuated.

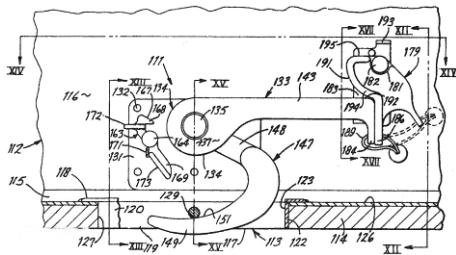

### References

#### Informative references

Attention is drawn to the following places, which may be of interest for search:

Locks giving indication of unauthorised unlocking	<a href="#">E05B 39/00</a>
Security seals	<a href="#">G09F 3/03</a>

## E05B 83/16

Locks for luggage compartments, car boot lids or car bonnets

### Definition statement

*This place covers:*

Lock devices for non-passenger compartments essentially located at the outside of the vehicle.

In most of the cases the rear compartments are used for load purposes, e.g. for luggage. This also covers locks for luggage compartments of hatchback/station (family) cars.

At the front of the car it usually concerns a hood for the engine compartment.

## E05B 83/18

for car boot lids or rear luggage compartments

### Definition statement

*This place covers:*

Locking arrangements for boot lids and luggage compartments, normally at the back of a car. A typical example of this subgroup is shown in the figure, whereby a lock (10) cooperates with a striker (20) for holding the boot lid (2) closed.

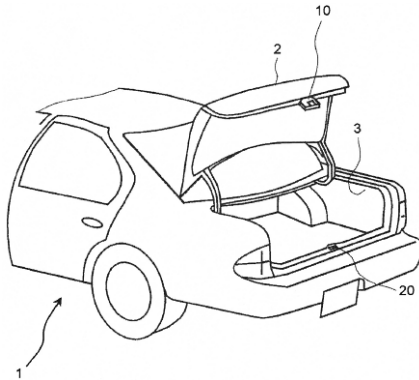

## E05B 83/20

with two or more wings, which together close a single compartment

### Definition statement

*This place covers:*

Locking arrangements for luggage compartments with more than one wing. One example of such a lock system is shown in the figure.

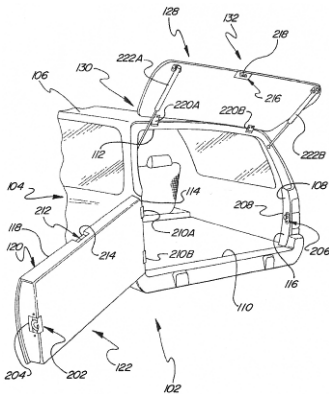

## E05B 83/22

for luggage compartments at the side of the vehicle, e.g. of buses or camper vans

### Definition statement

*This place covers:*

Locking arrangements for luggage compartments at the side of the vehicle, as exemplified by the figure, which shows a recreational vehicle with a central actuator (160) for locking and unlocking of several luggage compartment doors at the vehicle side.

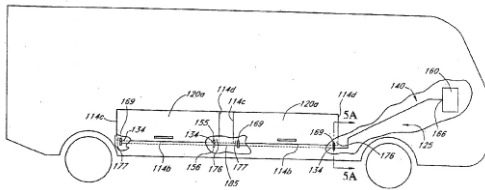

## E05B 83/24

for car bonnets

### Definition statement

*This place covers:*

Locks for compartments at the front of a vehicle. These locks are normally provided with a primary and secondary bolt in order to obtain a double security. This assures that the wing stays closed even if the primary bolt fails.

In the figure a striker (4) is held in the latched position by a primary bolt (8). A secondary bolt (5) catches the striker (4), if the primary bolt (8) would fail.

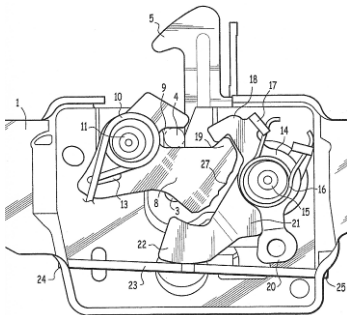

## E05B 83/26

Emergency opening means for persons trapped in the luggage compartment

### Definition statement

*This place covers:*

Arrangements for allowing escape from the inside of a boot. There are normally no means for actuating the boot lock from the inside.

Definition statement

This subgroup concerns means allowing operation from the inside in case of emergency. In the figure a handle (12) is provided for emergency opening.

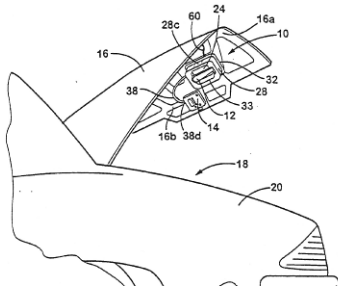

**E05B 83/30**

**for glove compartments**

**Definition statement**

*This place covers:*

Locks for storage compartments located in the dashboard area in front of the passenger seat. An example of such a device can be seen in the figure.

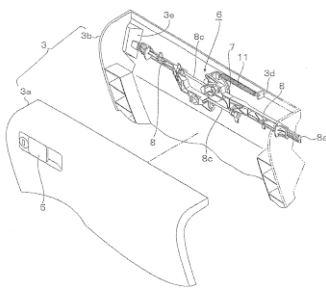

**E05B 83/32**

**for console boxes, e.g. between passenger seats**

**Definition statement**

*This place covers:*

Locking arrangements for storage compartments normally placed between passenger seats as exemplified by the figure.

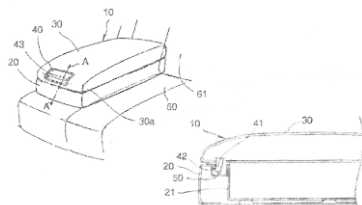

## E05B 83/34

### for fuel inlet covers essentially flush with the vehicle surface

#### Definition statement

*This place covers:*

Locks for fuel inlet covers, which essentially lie in the plane of the vehicle surface, when closed. In the figure a fuel inlet (9) is covered by a lid (4). An actuator (20) drives a bolt (16) between a locked and unlocked position. The caps which actually close the inlet pipe in a fluid-tight way (with or without lock) and the flush cover flaps, per se, are rather covered by [B60K 15/04](#) and [B60K 15/05](#)

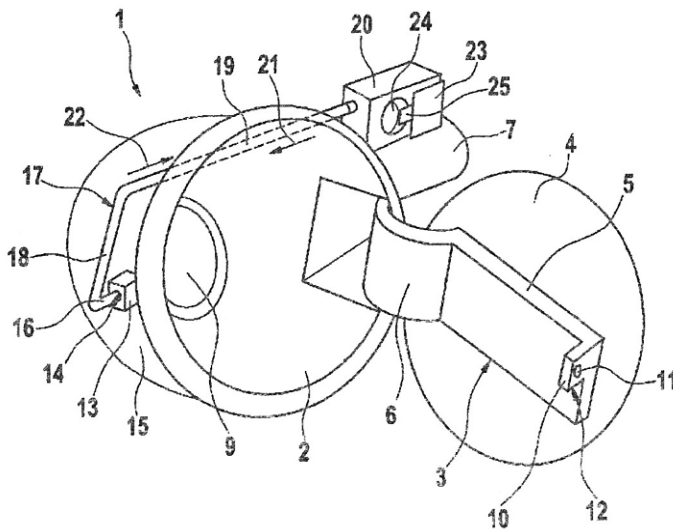

#### References

##### *Informative references*

*Attention is drawn to the following places, which may be of interest for search:*

Fuel inlet covers, as such	<a href="#">B60K 15/05</a>
----------------------------	----------------------------

## E05B 83/38

for pillar-less vehicles, i.e. vehicles where a front and a back door engage each other in the closed position

### Definition statement

*This place covers:*

Locks for door arrangements without a central post between the front and the back door. According to the exemplifying figure a pivoting door (PB) and a sliding door (PC) are kept in a closed position by a system comprising four different locks (DS1, DS2, TS, PS).

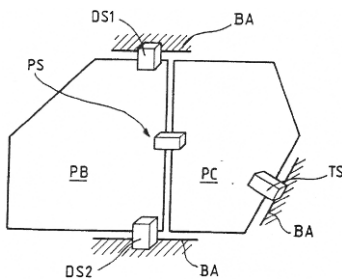

## E05B 83/40

for sliding doors

### Definition statement

*This place covers:*

Locking devices for sliding passenger doors. The example in the figure shows a lock system for a sliding door (D). It comprises a rear latch mechanism (11), a front latch mechanism (13) and a lower latch mechanism (17).

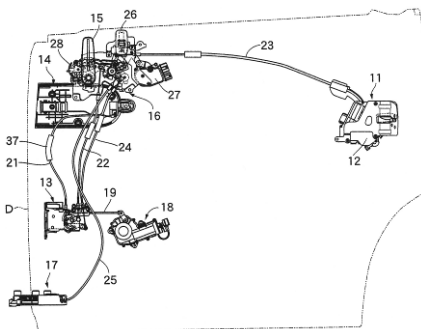

## E05B 83/42

for large commercial vehicles, e.g. trucks, construction vehicles or vehicles for mass transport

### Definition statement

*This place covers:*

Locks for passenger compartments of large commercially used vehicles. The figure shows a cabin (1) of a working vehicle. On the inside of the cabin door a handle (24) can be operated for releasing a door lock mechanism (22).

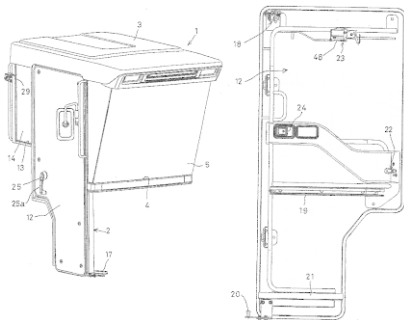

## E05B 83/44

for recreational vehicles, e.g. caravans or camper vans

### Definition statement

*This place covers:*

Locks for campers, caravans and similar. One commonly addressed problem is to secure the doors from the inside during night.

The figure is directed to a lock for a caravan, which can be locked and unlocked with a remote control (82).

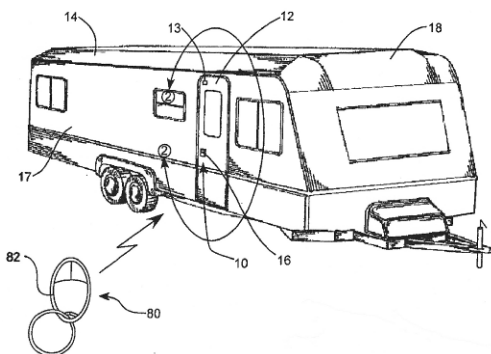

## E05B 85/02

### Lock casings

#### Definition statement

*This place covers:*

Housing structures for vehicle locks as exemplified by the figure, which shows a housing (6) composed of a plastic shell (7) and a metallic plate (9).

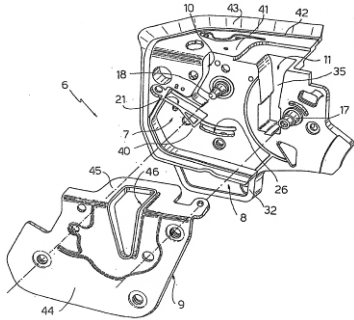

#### References

##### References out of a residual place

*Examples of places in relation to which this place is residual:*

Mounting of lock casings	<a href="#">E05B 79/04</a>
--------------------------	----------------------------

## E05B 85/04

### Strikers

#### Definition statement

*This place covers:*

Elements cooperating with the bolt for holding a wing closed. These striker elements are also called keepers. They are normally constructed as a pin or a staple for cooperation with a bifurcated latch bolt. A typical example is shown in the figure.

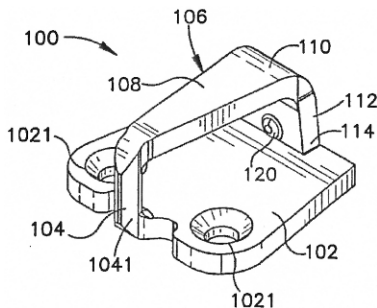



## E05B 85/06

### Lock cylinder arrangements

#### Definition statement

*This place covers:*

Arrangements of lock cylinders in vehicle lock devices. A usual subject of this subgroup is the connection between a lock cylinder and the lock mechanism in a lock housing. Such a construction is disclosed in the figure, wherein a lock cylinder (30) is connected to a lock mechanism (20) by means of a particular rod (4).

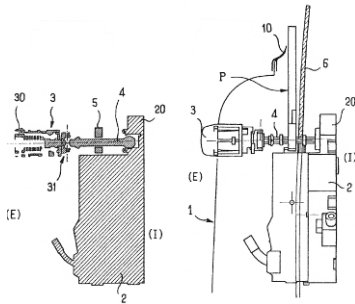

#### References

##### Informative references

*Attention is drawn to the following places, which may be of interest for search:*

Devices for coupling the turning cylinder of a single or double cylinder lock with the bolt-operating member	<a href="#">E05B 17/04</a>
--	----------------------------

## E05B 85/08

### Sill-buttons, garnish buttons or inner door lock knobs

#### Definition statement

*This place covers:*

Buttons or knobs on the inside of the door for locking/unlocking of the door. It usually concerns either a sill-button placed on the door trim near the window or a knob/button placed near or in the door handle unit. The figure gives an example of a sill/garnish button (11) arranged for actuation of a locking lever (12).

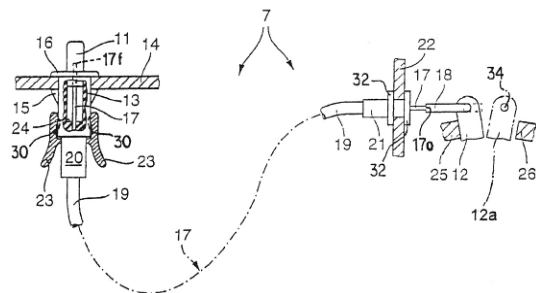

## References

### Informative references

Attention is drawn to the following places, which may be of interest for search:

Functions related to actuation of locks from the passenger compartment of the vehicle	<a href="#">E05B 77/22</a>
---	----------------------------

## E05B 85/10

### Handles

#### Definition statement

*This place covers:*

Various types of vehicle door handles for actuation of locks. The lower subgroups concern the most common groups of such handles.

## References

### Limiting references

*This place does not cover:*

Mounting of handles	<a href="#">E05B 79/06</a>
Operative connections of handles	<a href="#">E05B 79/22</a>

## E05B 85/12

### Inner door handles

#### Definition statement

*This place covers:*

Handles on the inside of the door as exemplified by the figure, in which a door handle (32) is provided for actuation of the door lock.

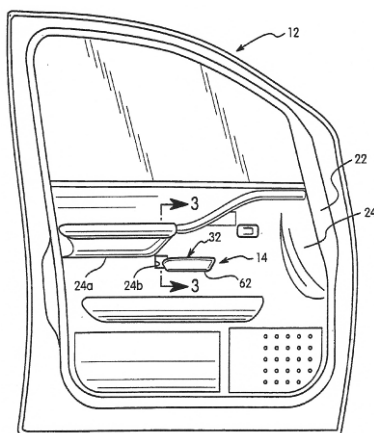

## E05B 85/14

### Handles pivoted about an axis parallel to the wing

#### Definition statement

*This place covers:*

Pivoting handle constructions with an axis essentially parallel to the plane of the wing. This is a very common type of handle movement, and the lower subgroups concern the most usual basic concepts. The example figure of this subgroup therefore discloses another type of such a pivoting handle.

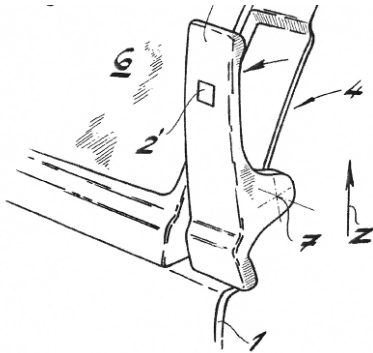

## E05B 85/16

### a longitudinal grip part being pivoted at one end about an axis perpendicular to the longitudinal axis of the grip part

#### Definition statement

*This place covers:*

One of the two most commonly used vehicle handle constructions. The figure illustrates how a longitudinal handle (1) pivots at one end (4) around an axis perpendicular to the longitudinal direction of the handle.

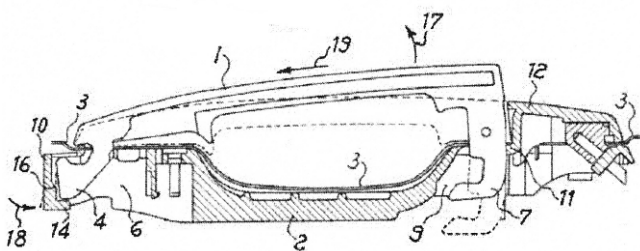

## E05B 85/18

a longitudinal grip part being pivoted about an axis parallel to the longitudinal axis of the grip part

### Definition statement

*This place covers:*

The second of the two most commonly used vehicle handle constructions. The figure illustrates how a longitudinal handle (16) pivots around an axis (27) parallel to the longitudinal direction of the handle.

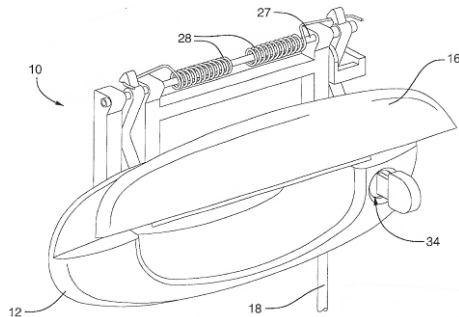

## E05B 85/20

Bolts or detents

### Definition statement

*This place covers:*

Details of locking elements in the form of e.g. latch-bolts or dead-bolts and detents for such bolts. A vehicle front hood lock comprising a bolt (2) with a combined rotational and sliding movement, as illustrated by the figure, would belong in this subgroup.

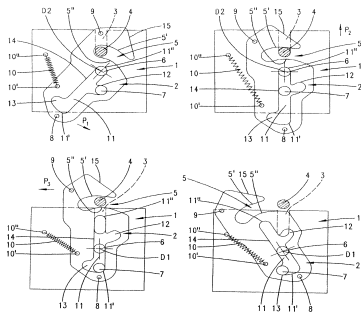

## E05B 85/22

### Rectilinearly moving bolts

#### Definition statement

*This place covers:*

Vehicle locks with sliding bolts as illustrated by the figure, in which an actuator (18) causes a sliding movement of a bolt (22).

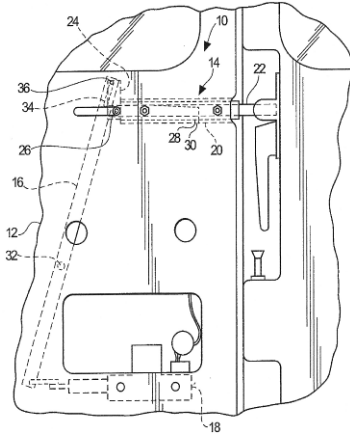

## E05B 85/24

### Bolts rotating about an axis

#### Definition statement

*This place covers:*

Vehicle locks with pivoting bolts. The vast majority of pivoting bolts in vehicle locks is of the bifurcated type. The example of the figure therefore shows a more unusual form of pivoting bolt. The striker (5) is guided onto a centering pin of the lock housing, when the door is closed. A hook element (3) of the bolt (2) will thereby come in contact with an edge (4) of the striker (5). The pivoting bolt (2) is held in the latched position by two detents (6, 10).

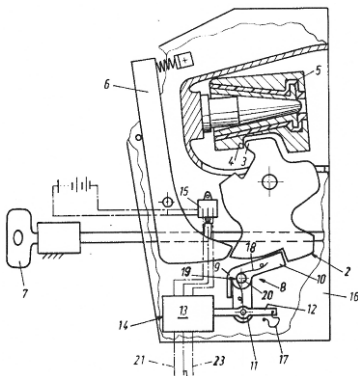

## E05B 85/26

### Cooperation between bolts and detents

#### Definition statement

*This place covers:*

Cases where the detent, the bolt or the way in which they cooperate is described. In the figure a bolt (2) and a detent (3) are provided with contact surfaces with specifically chosen curvatures.

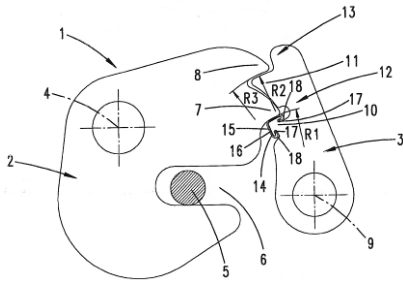

## E05B 85/28

### in which the member engaging the keeper is shaped as a toothed wheel or the like

#### Definition statement

*This place covers:*

Bolt members shaped as toothed wheels. This used to be a very common bolt/striker construction but is rather unusual nowadays.

The lock in the figure has a wheel shaped bolt (21) with toothed elements (14) which cooperate with a protrusion (35) on the striker for holding the wing closed.

