

B65D

CONTAINERS FOR STORAGE OR TRANSPORT OF ARTICLES OR MATERIALS, e.g. BAGS, BARRELS, BOTTLES, BOXES, CANS, CARTONS, CRATES, DRUMS, JARS, TANKS, HOPPERS, FORWARDING CONTAINERS; ACCESSORIES, CLOSURES, OR FITTINGS THEREFOR; PACKAGING ELEMENTS; PACKAGES

Definition statement

This place covers:

- Containers, packaging elements or packages with auxiliary means or provisions for displaying articles or materials;
- Methods of packaging which are wholly characterised by the form of the package produced or the form of the container or packaging element used, as distinct from the operations performed or the apparatus employed, which are covered by subclass [B65B](#).
- In this subclass, groups [B65D 5/00](#), [B65D 27/00](#), [B65D 29/00](#), [B65D 31/00](#) or [B65D 65/00](#) include constructional features of foldable or erectable container or wrapper blanks as well as the containers or wrappers formed by folding or erecting such blanks.
- Containers, packaging elements or packages classified in group [B65D 85/00](#), are also classified according to the constructional or functional features, if such features are of interest.

References

Informative references

Attention is drawn to the following places, which may be of interest for search:

containers specially adapted for storing agricultural or horticultural products	A01F 25/14
containers specially adapted for use in dairies	A01J
travelling bags or baskets, suitcases	A45C
travelling or camp equipment	A45F
linkable display containers	A47B 87/00
household or table equipment	A47G
letter-boxes for home use	A47G 29/12
kitchen equipment	A47J
associated with vehicles	B60 - B64
machines, apparatus, or devices for, or methods of, packaging articles or materials	B65B
sack holders	B65B 67/00
refuse receptacles	B65F 1/00
handling sheets, webs or filamentary material	B65H
load-engaging elements or devices attached to lifting or lowering gear of cranes or adapted for connection therewith for transmitting lifting forces	B66C
liquid handling	B67
storing gases	F17

Special rules of classification

The following orthogonal Indexing Codes are obligatory and applied to documents in [B65D 1/00](#) - [B65D 85/84](#) groups, however only if not covered by another Invention Information group, i.e. any of the [B65D 1/00](#) - [B65D 85/84](#) groups takes precedence.

[B65D 2401/00](#) - tamper indicating means, the following subgroups take precedence: [B65D 41/32](#), [B65D 43/0235](#), [B65D 51/20](#), [B65D 55/02](#)

[B65D 2201/00](#) - general orthogonal codes, may be used in [B65D 1/00](#) - [B65D 85/84](#) groups

[B65D 2301/00](#) - general orthogonal codes, may be used in [B65D 1/00](#) - [B65D 85/84](#) groups.

The following orthogonal codes are obligatory and are used only with the group(s) they relate to:

[B65D 2501/00](#) - bottles, [B65D 1/02](#) groups

[B65D 2501/24](#) - bottle crates, [B65D 1/24](#) groups

[B65D 2517/00](#) - cans, beverage cans, [B65D 17/00](#) groups

[B65D 2519/00](#) - pallets, [B65D 19/00](#) & sub-groups

[B65D 2525/00](#) - details of rigid or semi-rigid containers, e.g. handles, [B65D 25/00](#) groups

[B65D 2539/00](#) - corks, stoppers, [B65D 39/00](#) groups

[B65D 2543/00](#) - lids, covers, [B65D 43/00](#) groups

[B65D 2547/00](#) - closures with filling or discharging devices, e.g. pour spouts, [B65D 47/00](#) groups

[B65D 2555/00](#) - accessories for closures, [B65D 55/00](#) groups

[B65D 2563/00](#) - straps, e.g. for bundling, [B65D 63/00](#) groups

[B65D 2565/00](#) - special materials, e.g. recyclable or recycled, [B65D 65/00](#) groups

[B65D 2571/00](#) - palletisable loads, bundling wrappers or trays , [B65D 71/00](#) groups

[B65D 2575/00](#) - packages comprising articles enclosed between sheets or blanks, [B65D 75/00](#) groups

[B65D 2577/00](#) - container within a container; container closures formed after filling, [B65D 77/00](#) groups

[B65D 2581/00](#) - corner or edge protectors; microwave heating packages, [B65D 81/00](#) groups

[B65D 2583/00](#) - containers or packages with means for dispensing; pill dispensers, [B65D 83/00](#) groups

[B65D 2585/00](#) - pizza boxes; contact lenses containers for bulky articles; containers for machines, engines, or vehicles , [B65D 85/00](#) groups

Glossary of terms

In this place, the following terms or expressions are used with the meaning indicated:

Rigid or semi-rigid containers	Containers not deformed by, or not taking-up the shape of, their contents; Containers adapted to be temporarily deformed to expel their contents; Pallets; Trays.
Flexible containers	Containers deformed by, or taking-up the shape of, their contents; Containers adapted to be permanently deformed to expel their contents.

Packaging elements	Elements, other than containers, for covering, protecting, stiffening, or holding together articles or materials to be stored or transported; Packaging materials of special type or form not provided for in other subclasses.
Packages	Combination of containers or packaging elements with articles or materials to be stored or transported: Articles joined together for convenience of storage or transport.
Paper	Includes materials, e.g. cardboard, plastic sheet materials, laminated materials, or metal foils, worked in a manner analogous to paper.
Large containers	Containers having about the size of containers used in container traffic, sometimes referred to as freight, forwarding or "ISO" (International Standardization) containers, or larger containers.

B65D 1/00

Containers having bodies formed in one piece, e.g. by casting metallic material, by moulding plastics, by blowing vitreous material, by throwing ceramic material, by moulding pulped fibrous material, by deep-drawing operations performed on sheet material (by winding, bending, or folding paper [B65D 3/00](#), [B65D 5/00](#); specially constructed to be opened by cutting, piercing, or tearing of wall portions [B65D 17/00](#); pallets [B65D 19/00](#); details of bottles or of jars [B65D 23/00](#); bundles of articles held together by packaging elements for convenience of storage or transport, e.g. portable segregating carriers for plural receptacles such as beer cans, pop bottles, [B65D 71/00](#))

References

Limiting references

This place does not cover:

Producing hollow articles (plastic)	B29D 22/00
-------------------------------------	----------------------------

Informative references

Attention is drawn to the following places, which may be of interest for search:

Details of bottles or jars	B65D 23/00
Bundles of articles held together by packaging elements for convenience of storage or transport, e.g. portable segregating carriers for plural receptacles such as beer cans or pop bottles	B65D 71/00

B65D 1/02

Bottles or similar containers with necks or like restricted apertures, designed for pouring contents (thermally-insulated containers [B65D 81/38](#), [A47J 41/00](#); {feeding-bottles [A61J 9/00](#)})

References**Limiting references**

This place does not cover:

Integral bottle openers	B65D 1/0269
-------------------------	-----------------------------

Informative references

Attention is drawn to the following places, which may be of interest for search:

Thermally insulated containers	A47J 41/00 , B65D 81/38
For fabrication details	B29L 2031/7158

Special rules of classification

The use of available Indexing Codes is mandatory.

B65D 1/0207

{characterised by material, e.g. composition, physical features}

References**Informative references**

Attention is drawn to the following places, which may be of interest for search:

For fabrication details	B29L 2031/7158
-------------------------	--------------------------------

Special rules of classification

The use of available Indexing Codes is mandatory.

B65D 1/0215**{multilayered ([B65D 81/3837](#) takes precedence)}****Definition statement***This place covers:*

Illustrative example of subject matter classified in this group:

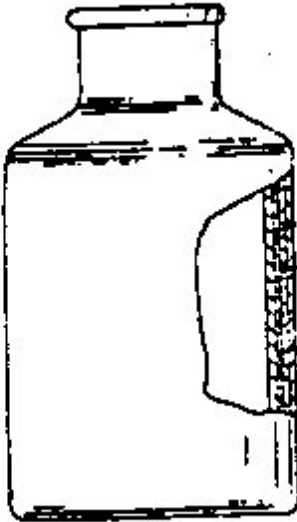
**References****Limiting references***This place does not cover:*

Rigid container in the form of a bottle, jar or like container	B65D 81/3837
--	------------------------------

Informative references*Attention is drawn to the following places, which may be of interest for search:*

Linings or internal coatings	B65D 23/02
Coverings or external coatings	B65D 23/08
For fabrication details	B29L 2031/7158

Special rules of classification

The use of available Indexing Codes is mandatory.

B65D 1/0223**{characterised by shape}****References****Informative references***Attention is drawn to the following places, which may be of interest for search:*

For tearing along a line or from a point of weakness provided in the sidewall	B65D 17/402
For fabrication details	B29L 2031/7158

Special rules of classification

The use of available Indexing Codes is mandatory.

B65D 1/023**{Neck construction}****Definition statement***This place covers:*

Illustrative example of subject matter classified in this group:

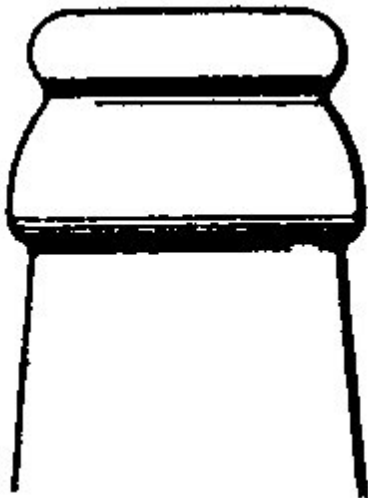
**References****Informative references***Attention is drawn to the following places, which may be of interest for search:*

For fabrication details	B29L 2031/7158
-------------------------	--------------------------------

Special rules of classification

The use of available Indexing Codes is mandatory.

B65D 1/0238**{Integral frangible closures}****Definition statement***This place covers:*

Illustrative example of subject matter classified in this group:

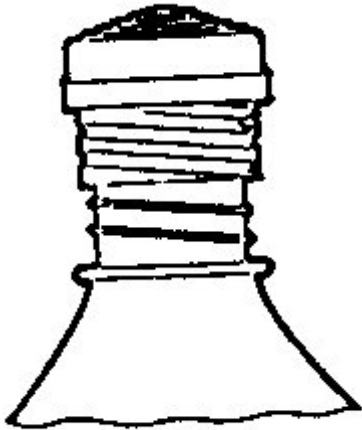
**References*****Informative references****Attention is drawn to the following places, which may be of interest for search:*

Integral, or permanently secured, end or side closures	B65D 17/06
By destroying, in the act of opening the container, an integral portion thereof	B65D 49/12

Special rules of classification

The use of available Indexing Codes is mandatory.

B65D 1/0246

{Closure retaining means, e.g. beads, screw-threads}

Definition statement

This place covers:

Illustrative example of subject matter classified in this group:

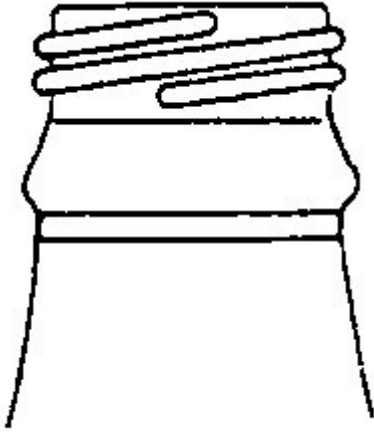

Special rules of classification

The use of available Indexing Codes is mandatory.

B65D 1/0253

{Means facilitating removal of the closure, e.g. cams, levers}

Definition statement

This place covers:

Illustrative example of subject matter classified in this group:

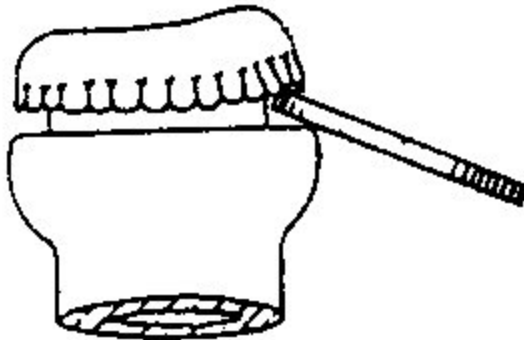

Special rules of classification

The use of available Indexing Codes is mandatory.

B65D 1/0261**{Bottom construction ([B65D 1/06](#) takes precedence)}****Definition statement***This place covers:*

Illustrative example of subject matter classified in this group:

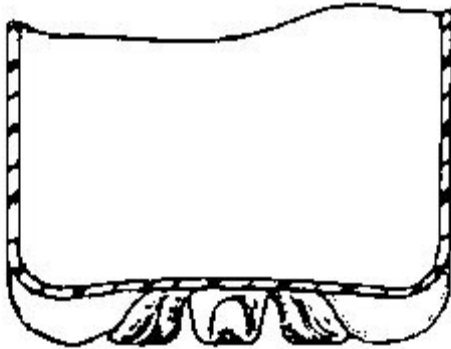
**References*****Limiting references****This place does not cover:*

With closable apertures at bottom	B65D 1/06
-----------------------------------	---------------------------

Informative references*Attention is drawn to the following places, which may be of interest for search:*

For fabrication details	B29L 2031/7158
-------------------------	--------------------------------

Special rules of classification

The use of available Indexing Codes is mandatory.

B65D 1/0269

{Openers}

Definition statement

This place covers:

Illustrative example of subject matter classified in this group:

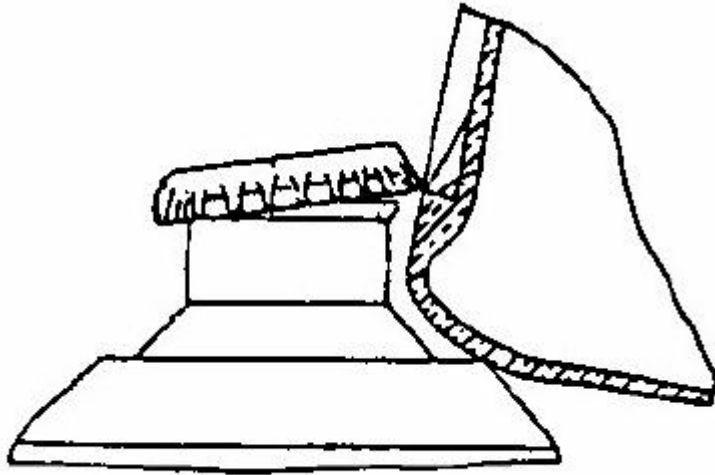

Special rules of classification

The use of available Indexing Codes is mandatory.

B65D 1/0276

{having a continuous contact surface, e.g. Champagne-type bottom}

Definition statement

This place covers:

Illustrative example of subject matter classified in this group:

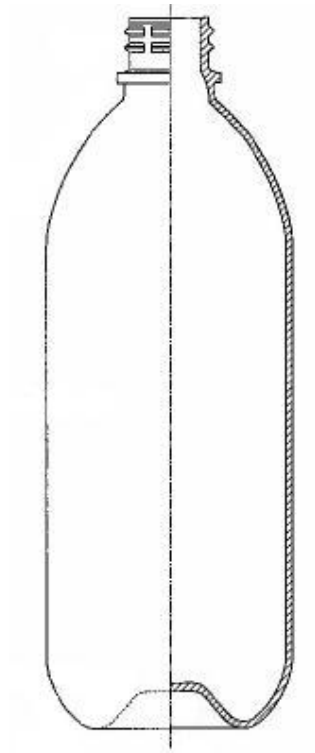

Special rules of classification

The use of available Indexing Codes is mandatory.

B65D 1/0284

{having a discontinuous contact surface, e.g. discrete feet}

Definition statement

This place covers:

Illustrative example of subject matter classified in this group:

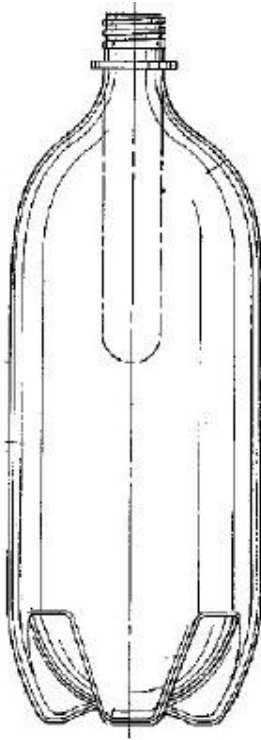

Special rules of classification

The use of available Indexing Codes is mandatory.

B65D 1/0292**{Foldable bottles}****Definition statement***This place covers:*

Illustrative example of subject matter classified in this group:

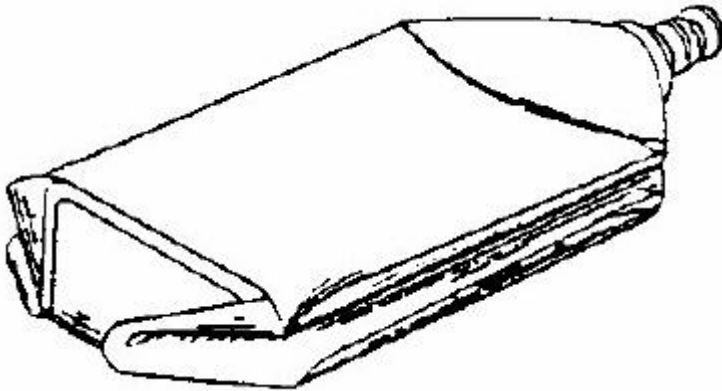
**References****Limiting references***This place does not cover:*

'Accordion' bottles, bottles collapsing within themselves see also	B65D 1/32
Bottles made of several parts with variable capacity	B65D 11/04
Other foldable containers of the same construction	B65D 21/08

Informative references*Attention is drawn to the following places, which may be of interest for search:*

For fabrication details	B29L 2031/7158
-------------------------	--------------------------------

Special rules of classification

The use of available Indexing Codes is mandatory.

B65D 1/04**Multi-cavity bottles****Definition statement**

This place covers:

Illustrative example of subject matter classified in this group:

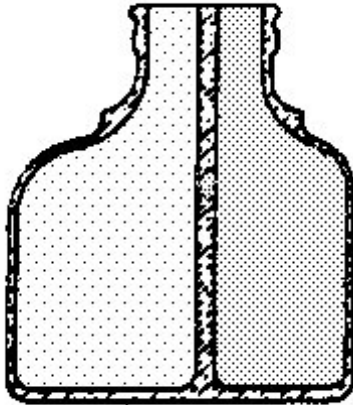
**References****Informative references**

Attention is drawn to the following places, which may be of interest for search:

Rigid containers disposed one within the other arranged parallel or concentrically and permitting simultaneous dispensing of the two materials without prior mixing	B65D 81/3227
Flexible containers disposed within rigid containers arranged parallel or concentrically and permitting simultaneous dispensing of the two materials without prior mixing	B65D 81/3244
Cylindrical or polygon containers	B65D 81/3283

B65D 1/06**with closable apertures at bottom****Definition statement***This place covers:*

Illustrative example of subject matter classified in this group:

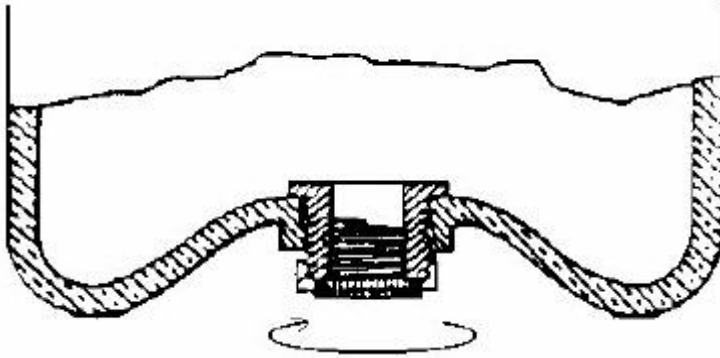
**B65D 1/08****adapted to discharge drops (droppers [B65D 47/18](#))****Definition statement***This place covers:*

Illustrative example of subject matter classified in this group:

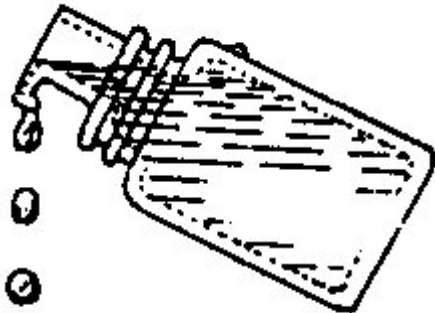
**References****Limiting references***This place does not cover:*

Eye-droppers	A61F 9/0008
Droppers in general	B01L 3/00

B65D 1/09

**Ampoules (specially adapted for medical or pharmaceutical purposes
[A61J 1/06](#))**

Definition statement

This place covers:

Illustrative example of subject matter classified in this group:



References

Informative references

Attention is drawn to the following places, which may be of interest for search:

Integral frangible closures	B65D 1/0238
Ampoules	B65D 81/3277

B65D 1/095**{made of flexible material}****Definition statement***This place covers:*

Illustrative example of subject matter classified in this group:

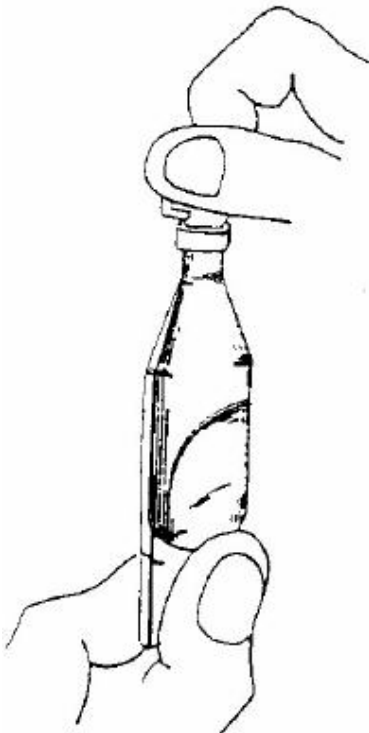
**References****Informative references***Attention is drawn to the following places, which may be of interest for search:*

Integral frangible closures	B65D 1/0238
Flexible ampoules, the contents of which are expelled by squeezing	A61J 1/067

B65D 1/12**Cans, casks, barrels, or drums****References****Limiting references***This place does not cover:*

Oil cans used also to receive used oil	F01M 11/0458 , F16N 31/002
--	---

Informative references

Attention is drawn to the following places, which may be of interest for search:

Bottles, canisters or jars whereby the neck or handle project into a cooperating cavity in the bottom	B65D 21/0231
---	------------------------------

B65D 1/14

characterised by shape

References**Informative references**

Attention is drawn to the following places, which may be of interest for search:

Bottles, canisters or jars whereby the neck or handle project into a cooperating cavity in the bottom	B65D 21/0231
---	------------------------------

B65D 1/165

{Cylindrical cans}

Definition statement

This place covers:

Illustrative example of subject matter classified in this group:

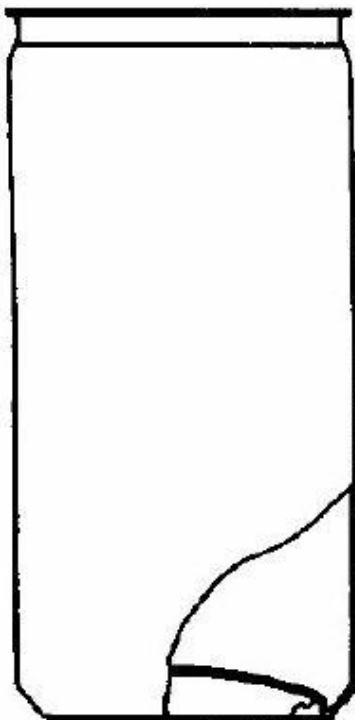

B65D 1/20

characterised by location or arrangement of filling or discharge apertures

Definition statement

This place covers:

Illustrative example of subject matter classified in this group:

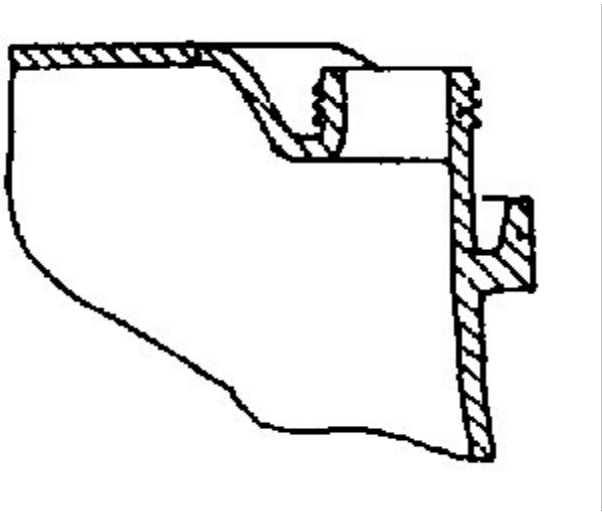
**References****Limiting references**

This place does not cover:

Made of several parts	B65D 7/40 , B65D 11/08
-----------------------	--

B65D 1/22

Boxes or like containers with side walls of substantial depth for enclosing contents {([B65D 43/162](#), [B65D 81/02](#), [B65D 81/3813](#) take precedence)}

References**Limiting references**

This place does not cover:

The container, the lid and the hinge being made of one piece	B65D 43/162
Specially adapted to protect contents from mechanical damage	B65D 81/02
Rigid container being in the form of a box, tray or like container	B65D 81/3813
For the making of containers	B29L 2031/7158

B65D 1/225**{Collapsible boxes}****Definition statement***This place covers:*

Illustrative example of subject matter classified in this group:

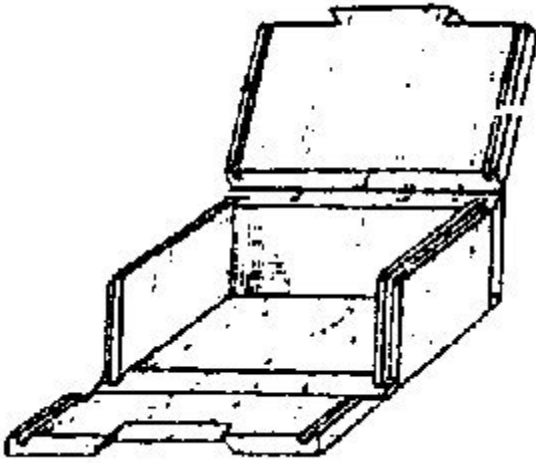
**References****Limiting references***This place does not cover:*

Made by folding a blank of plastic material	B65D 5/00 , B65D 2301/20
Made of two or more pieces	B65D 11/186

B65D 1/24**with moulded compartments or partitions****References****Limiting references***This place does not cover:*

For the making of crates	B29L 2031/7134
--------------------------	--------------------------------

B65D 1/243**{Crates for bottles or like containers}****Definition statement***This place covers:*

Illustrative example of subject matter classified in this group:

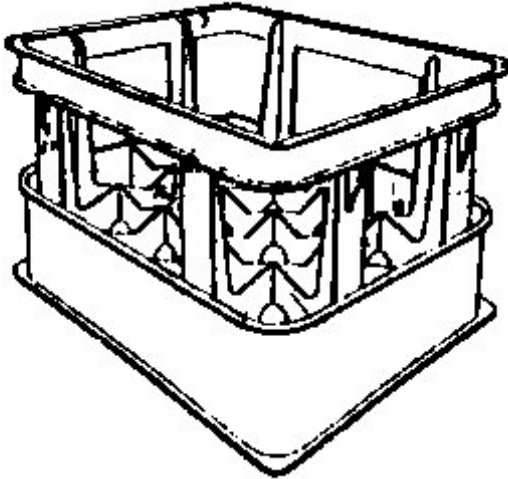
**References****Limiting references***This place does not cover:*

If no partitions or pillars	B65D 1/22
For the making of crates	B29L 2031/7134

Informative references*Attention is drawn to the following places, which may be of interest for search:*

Bottle-crates	B65D 85/305
---------------	-----------------------------

Special rules of classification

The use of available Indexing Codes is mandatory.

B65D 1/246

{Cover elements inserted in crates}

Definition statement

This place covers:

Illustrative example of subject matter classified in this group:

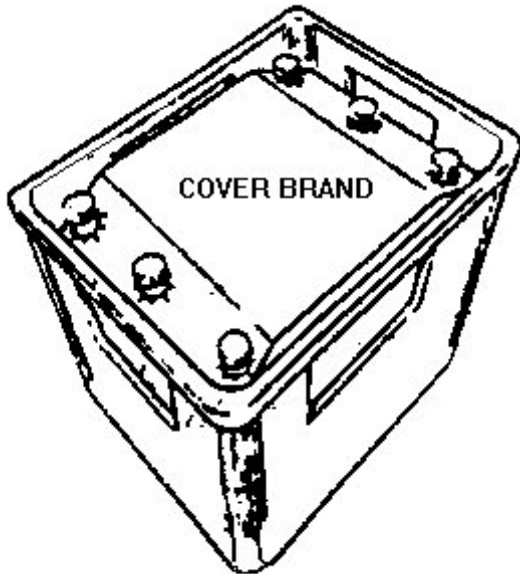

B65D 1/265

{Drinking cups ([B65D 81/3865](#) takes precedence, holders for plastic cups [A47G 23/0208](#))}

Definition statement

This place covers:

Illustrative example of subject matter classified in this group:



References

Limiting references

This place does not cover:

Drinking cups or like containers	B65D 81/3865
Drinking vessels or saucers used for table service	A47G 19/22

Informative references

Attention is drawn to the following places, which may be of interest for search:

Nestable cups, but nestable containers in general	B65D 21/0233
---	------------------------------

B65D 1/28

formed of laminated material

Definition statement

This place covers:

Illustrative example of subject matter classified in this group:

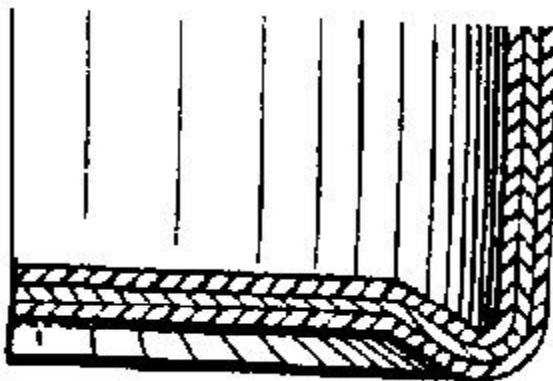

B65D 1/30**Groups of containers joined together end-to-end or side-by-side****Definition statement**

This place covers:

Illustrative example of subject matter classified in this group:

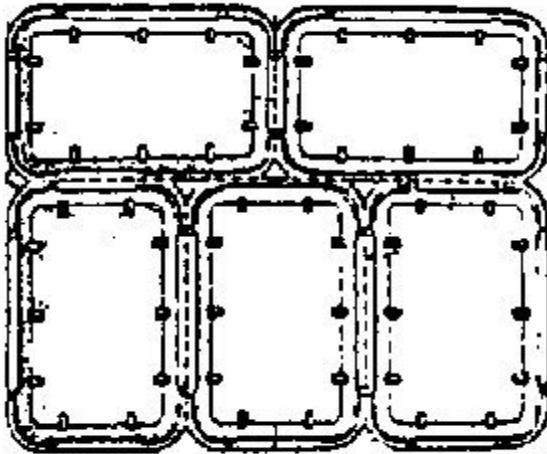
**References****Limiting references**

This place does not cover:

Freezing trays for ice-cubes	F25C 1/243
------------------------------	----------------------------

Informative references

Attention is drawn to the following places, which may be of interest for search:

Articles joined together for convenience of storage or transport without the use of packaging elements	B65D 69/00
The sheet or blank being recessed to accommodate contents and formed with several recesses to accommodate a series of articles or quantities of materials	B65D 75/24
One or both sheets or blanks being recessed to accommodate contents and having several recesses to accommodate a series of articles or quantities of material	B65D 75/34

B65D 1/32

Containers adapted to be temporarily deformed by external pressure to expel contents ({[B65D 47/2018](#), [B65D 83/0055](#) take precedence } ; containers for pharmaceutical purposes [A61J 1/20](#), [A61M 5/19](#); containers with disinfecting linings [A61L 2/00](#); liquid sprayers [B05B](#); oil cans [F16N 3/00](#))

Definition statement

This place covers:

Illustrative example of subject matter classified in this group:

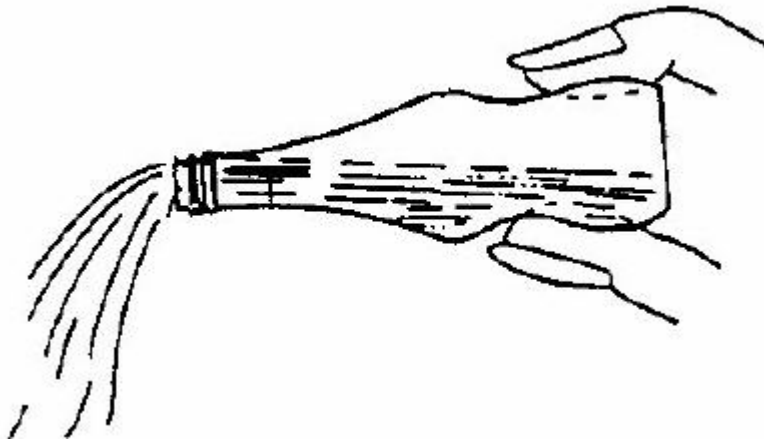

References

Application-oriented references

Examples of places where the subject matter of this place is covered when specially adapted, used for a particular purpose, or incorporated in a larger system:

Containers with disinfectant linings	A61L 2/00
--------------------------------------	---------------------------

Informative references

Attention is drawn to the following places, which may be of interest for search:

Foldable bottles	B65D 1/0292
Body construction made in one piece	B65D 35/04
Body construction made in one piece from metallic material	B65D 35/06
Body construction made in one piece from plastics material	B65D 35/08
Containers having an external wall formed as, or with, a diaphragm or the like which is deformed to expel the contents	B65D 83/0094

B65D 1/323

{the container comprising internally a dip tube through which the contents pass}

Definition statement

This place covers:

Illustrative example of subject matter classified in this group:

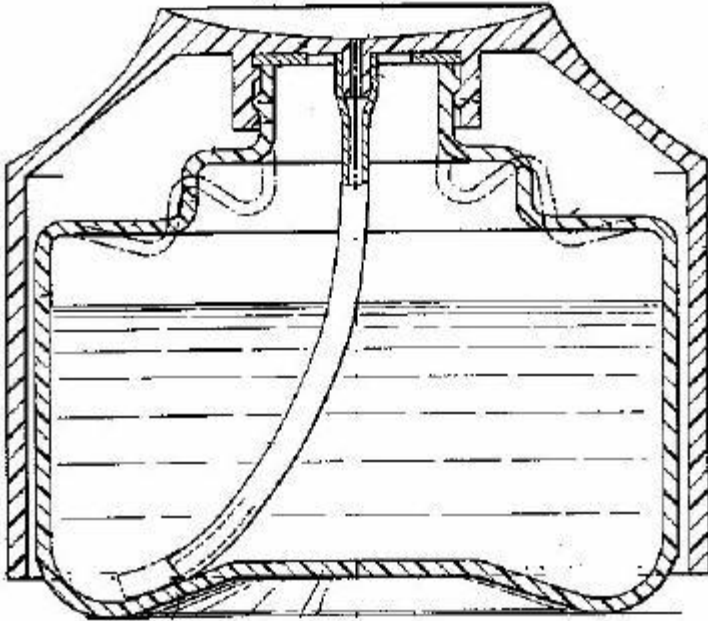

B65D 1/326

{the container comprising an, externally located, integrally formed tube through which the contents pass (integrally formed suction tubes [B65D 77/286](#))}

Definition statement

This place covers:

Illustrative example of subject matter classified in this group:

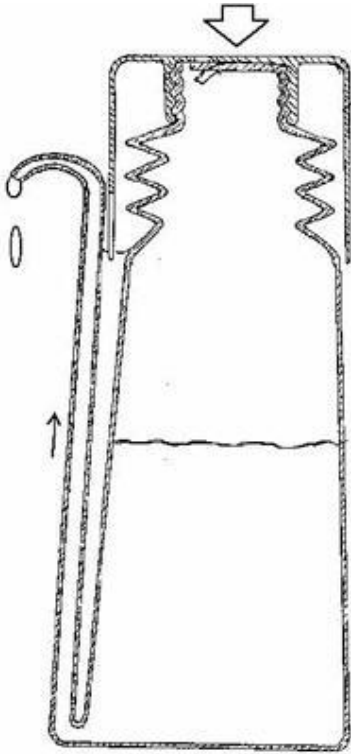

B65D 1/34

Trays or like shallow containers {([B65D 81/3813](#) takes precedence)}

Definition statement

This place covers:

Illustrative example of subject matter classified in this group:

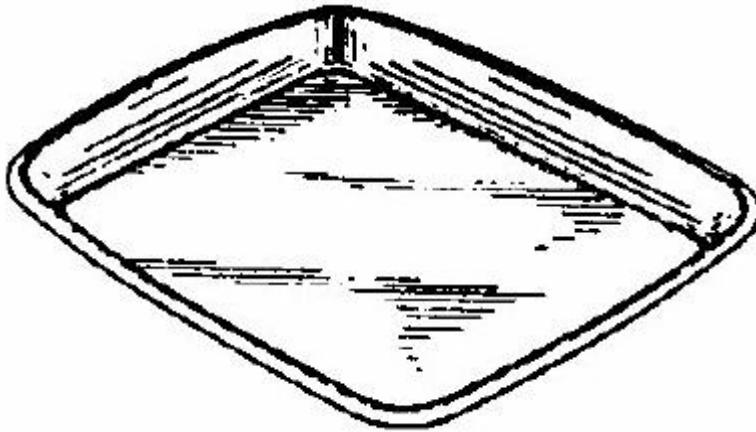
**References****Limiting references**

This place does not cover:

For draining or collecting liquids without absorbing them	B65D 81/261
For absorbing liquids	B65D 81/264
Rigid container being in the form of a box, tray or like container	B65D 81/3813
Freezing trays for ice-cubes	F25C 1/243

B65D 1/36

with moulded compartments or partitions

Definition statement

This place covers:

Illustrative example of subject matter classified in this group:

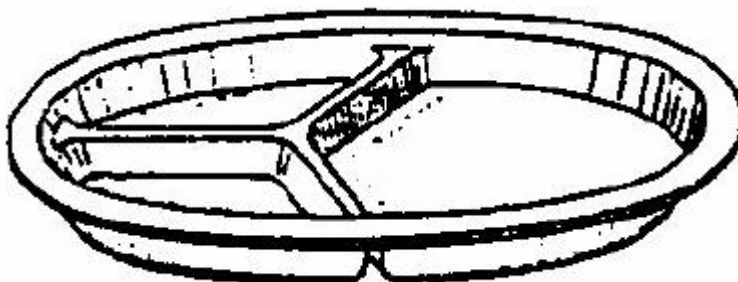

References

Limiting references

This place does not cover:

Plates with integral holders for spoons, glasses, or the like	A47G 19/06
Serving trays	A47G 23/06

Informative references

Attention is drawn to the following places, which may be of interest for search:

Tray-like elements formed in one piece	B65D 5/503
Applications of resilient shock-absorbing materials	B65D 65/44
Thermoformed trays or the like with a plurality of recesses for different materials located in different recesses	B65D 81/3294
For fruit	B65D 85/34

B65D 1/38

Baskets or like containers of skeleton or apertured construction {(crates for bottles or like containers [B65D 1/243](#))}

Definition statement

This place covers:

Illustrative example of subject matter classified in this group:

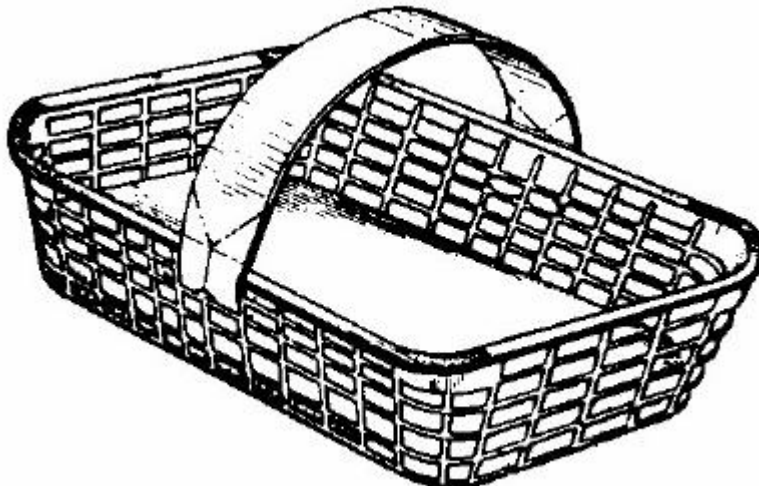

References

Limiting references

This place does not cover:

Flexible, net-like containers made of plastic material	B65D 29/04
--	----------------------------

Informative references

Attention is drawn to the following places, which may be of interest for search:

Containers having bodies formed by inter-connecting or uniting two or more rigid, or substantially rigid, components made wholly or mainly of plastics material of skeleton or apertured construction	B65D 11/14
Net-like containers made of plastics material	B65D 29/04

B65D 1/40

Details of walls (other container details [B65D 23/00](#), [B65D 25/00](#))

References**Limiting references**

This place does not cover:

Deformable walls for indicating or neutralising internal pressure variations	B65D 79/005
--	-----------------------------

Informative references

Attention is drawn to the following places, which may be of interest for search:

Other container details	B65D 23/00 , B65D 25/00
-------------------------	---

B65D 1/46

Local reinforcements, e.g. adjacent closures

Definition statement

This place covers:

Illustrative example of subject matter classified in this group:

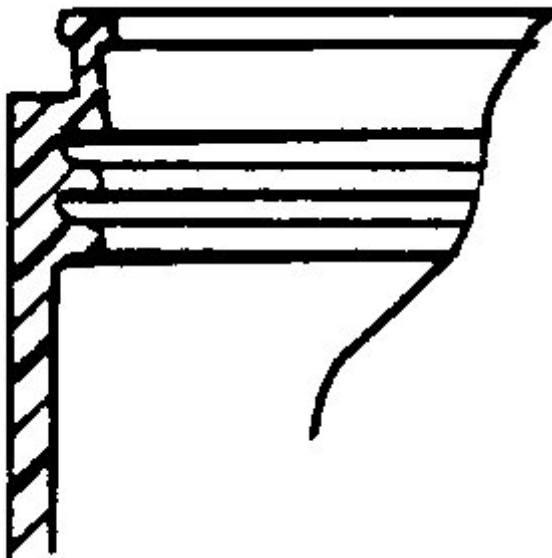

B65D 1/48

Reinforcements of dissimilar materials, e.g. metal frames in plastic walls

Definition statement

This place covers:

Illustrative example of subject matter classified in this group:

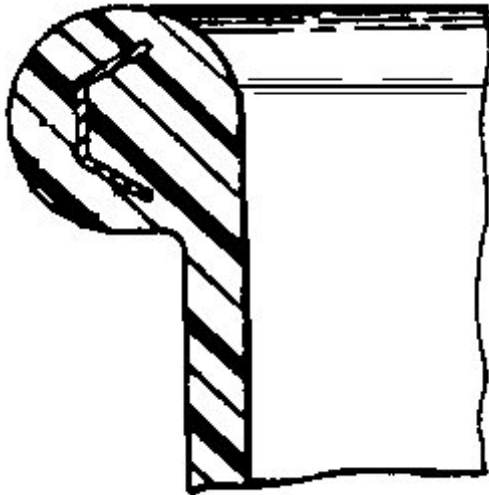

B65D 3/00

Rigid or semi-rigid containers having bodies or peripheral walls of curved or partially-curved cross-section made by winding or bending paper without folding along defined lines

References

Informative references

Attention is drawn to the following places, which may be of interest for search:

The tubular body having a curved or partially curved cross-section	B65D 5/0209
--	-----------------------------

B65D 3/08

having a cross-section of varying shape, e.g. circular merging into square or rectangular

Definition statement

This place covers:

Illustrative example of subject matter classified in this group:

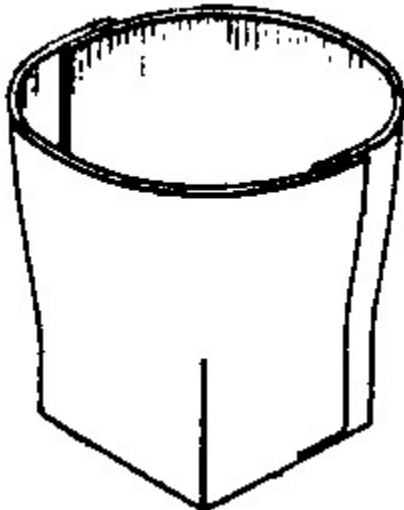
**References****Informative references**

Attention is drawn to the following places, which may be of interest for search:

The tubular body having a curved or partially curved cross-section	B65D 5/0209
--	-----------------------------

B65D 3/10

characterised by form of integral or permanently secured end closure

References**Limiting references**

This place does not cover:

End closure not made of paper	B65D 15/04
-------------------------------	----------------------------

B65D 3/12

Flanged discs permanently secured, e.g. by adhesives or by heat-sealing

Definition statement

This place covers:

Illustrative example of subject matter classified in this group:

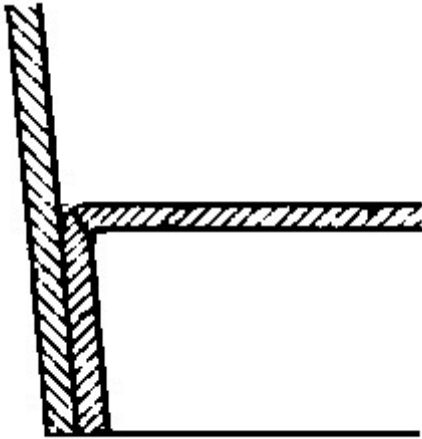

B65D 3/14

Discs fitting within container end and secured by bending, rolling, or folding operations

Definition statement

This place covers:

Illustrative example of subject matter classified in this group:

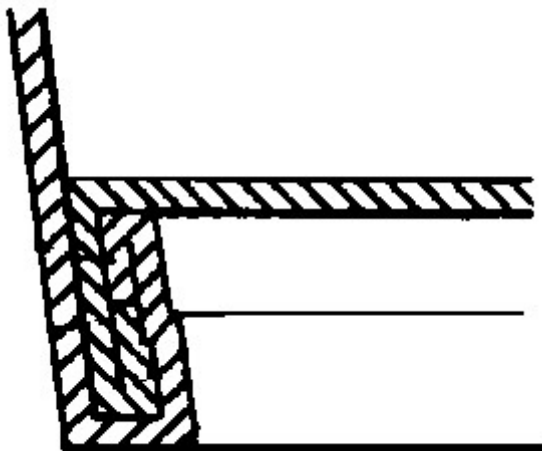

B65D 3/16

Discs without flanges engaging a groove in the container body

Definition statement

This place covers:

Illustrative example of subject matter classified in this group:

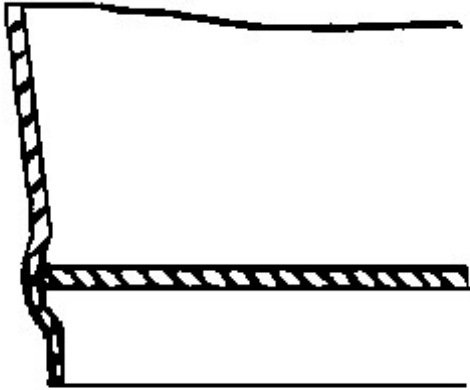

B65D 3/18

and secured by rolling in the end of the body

Definition statement

This place covers:

Illustrative example of subject matter classified in this group:

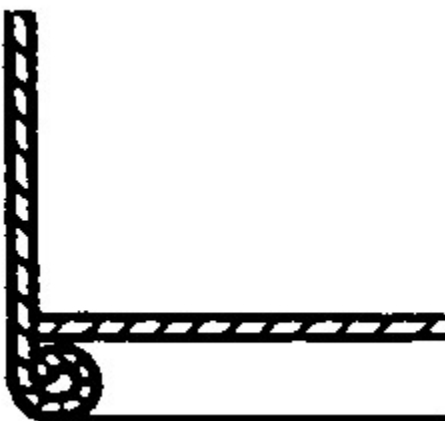

B65D 3/20

with end portion of body adapted to be closed, by flattening or folding operations, e.g. formed with crease lines or flaps

Definition statement

This place covers:

Illustrative example of subject matter classified in this group:

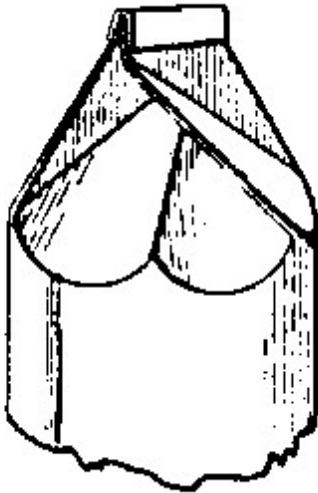

B65D 3/22

with double walls; with walls incorporating air-chambers; with walls made of laminated material {(for thermal insulating purposes [B65D 81/3818](#))}

Definition statement

This place covers:

Illustrative example of subject matter classified in this group:

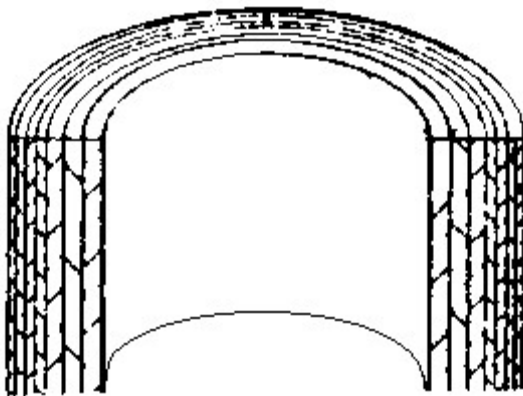

B65D 3/262

{forming a circumferential line of weakness}

Definition statement

This place covers:

Illustrative example of subject matter classified in this group:

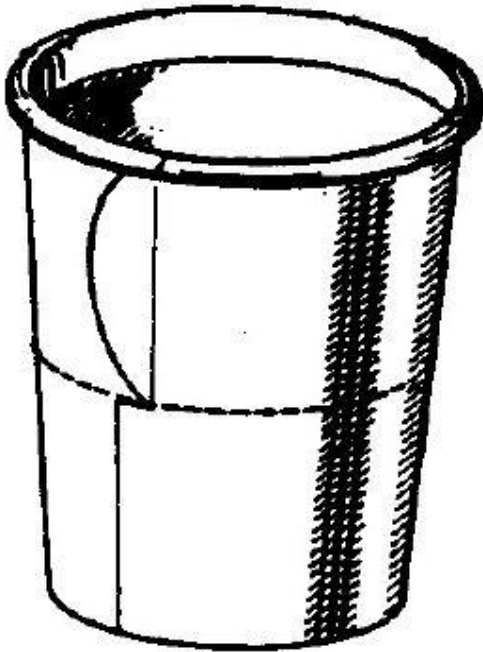

References

Informative references

Attention is drawn to the following places, which may be of interest for search:

Tear-lines for removing successive sections of a package	B65D 75/5888
--	------------------------------

B65D 3/263

{and having an attached or applied tearing or reinforcing element}

Definition statement

This place covers:

Illustrative example of subject matter classified in this group:

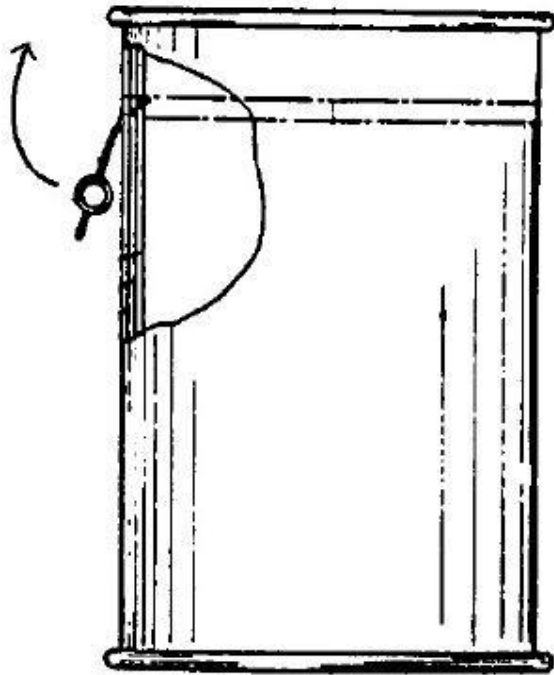

B65D 3/264

{forming a longitudinal line of weakness}

Definition statement

This place covers:

Illustrative example of subject matter classified in this group:

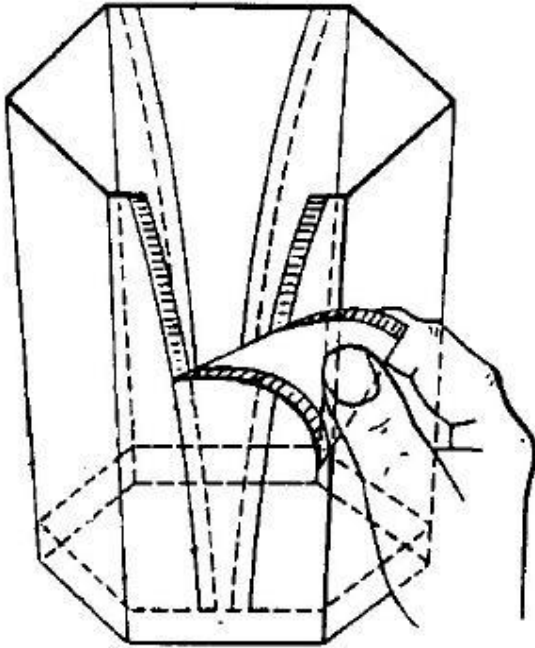

B65D 3/265

{and having an attached or applied tearing or reinforcing element}

Definition statement

This place covers:

Illustrative example of subject matter classified in this group:

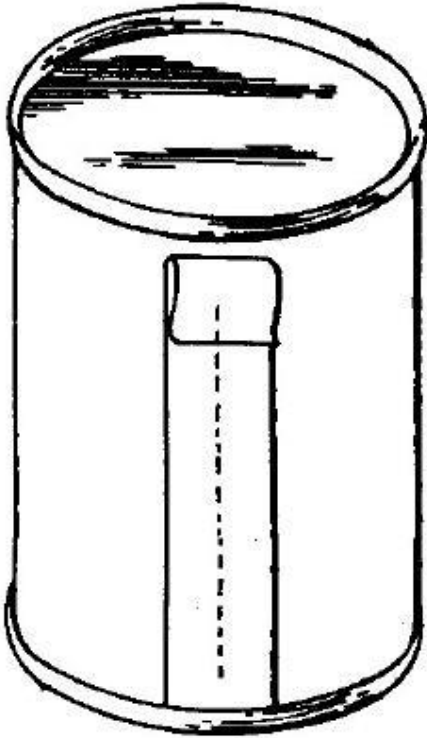

B65D 3/266

{forming a helical line of weakness}

Definition statement

This place covers:

Illustrative example of subject matter classified in this group:

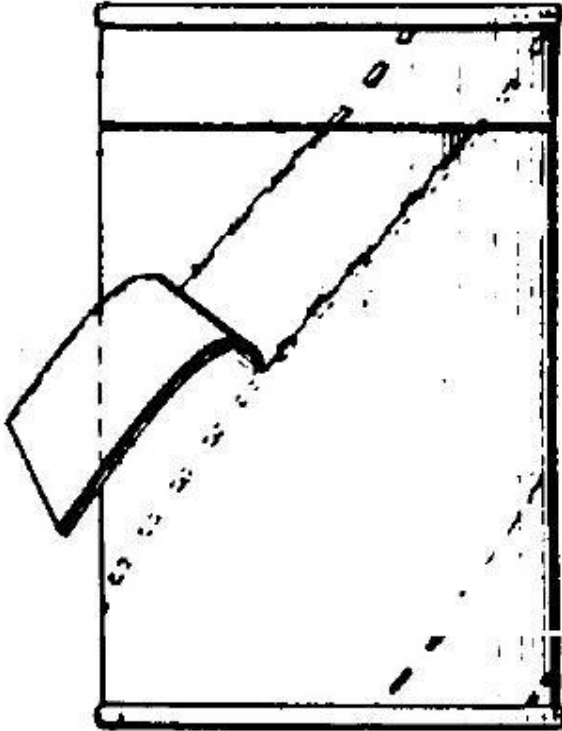

B65D 3/267

{and having an attached or applied tearing or reinforcing element}

Definition statement

This place covers:

Illustrative example of subject matter classified in this group:

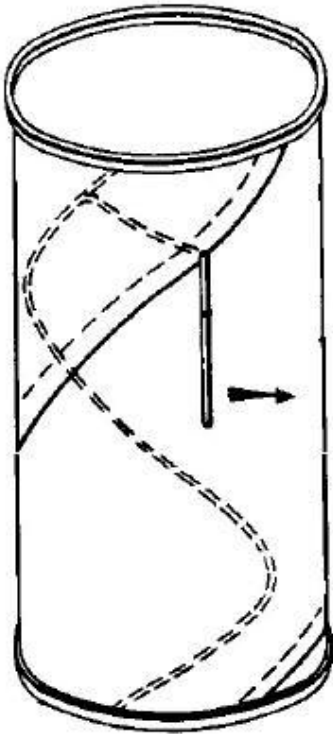

B65D 3/268

{the opening arrangement being located in a container closure}

Definition statement

This place covers:

Illustrative example of subject matter classified in this group:

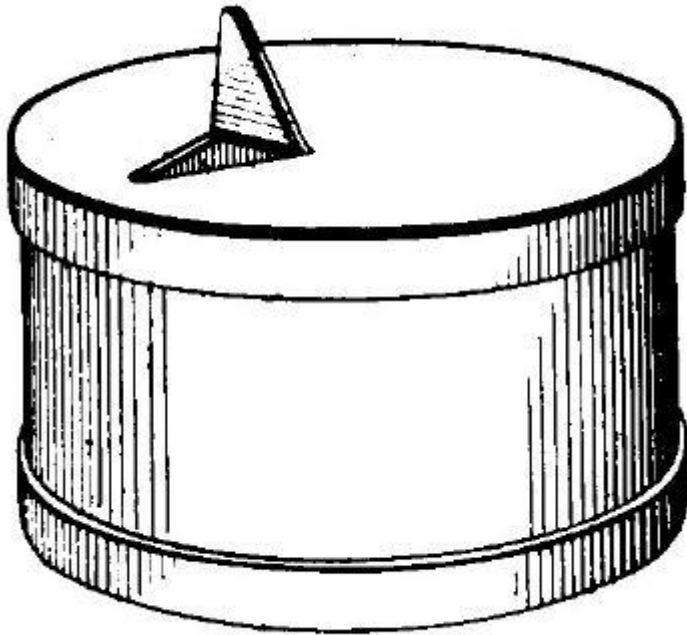

B65D 3/28

Other details of walls

Special rules of classification

The use of available Indexing Codes is mandatory.

B65D 3/30**Local reinforcements, e.g. metallic rims****Definition statement***This place covers:*

Illustrative example of subject matter classified in this group:

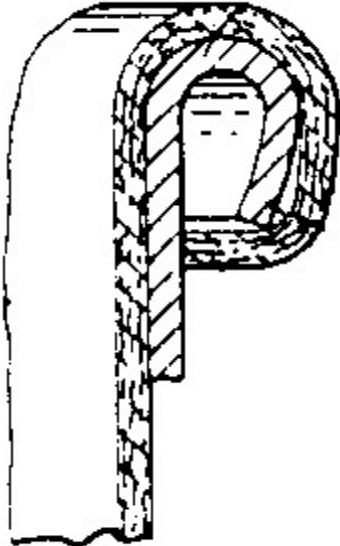
**B65D 5/00****Rigid or semi-rigid containers of polygonal cross-section, e.g. boxes, cartons or trays, formed by folding or erecting one or more blanks made of paper (rigid pallets with side walls [B65D 19/02](#))****References****Limiting references***This place does not cover:*

Holders or wrappers as eating aids for fast food, e.g. hamburgers	A47G 21/001
---	-----------------------------

Informative references*Attention is drawn to the following places, which may be of interest for search:*

Bundles of articles held together by packaging elements for convenience of storage or transport, e.g. portable segregating carriers for plural receptacles such as beer cans, pop bottles	B65D 71/00
---	----------------------------

B65D 5/0005**{of variable capacity}****References****Limiting references***This place does not cover:*

Collapsible	B65D 5/36
-------------	---------------------------

Informative references*Attention is drawn to the following places, which may be of interest for search:*

Containers of variable capacity	B65D 21/08
---------------------------------	----------------------------

B65D 5/002**{having integral corner posts ([B65D 5/0045](#) and [B65D 5/0065](#) take precedence)}****Definition statement***This place covers:*

Illustrative example of subject matter classified in this group:

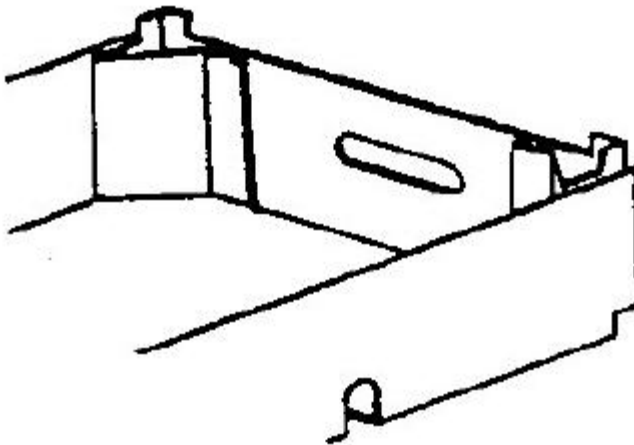
**References****Limiting references***This place does not cover:*

Having both integral corner posts and ledges	B65D 5/0045
Separate elements inserted in or attached to integral corner posts or ledges	B65D 5/0065

B65D 5/0025

{the corner posts being formed as a prolongation of a doubled-over extension of the side walls}

Definition statement

This place covers:

Illustrative example of subject matter classified in this group:

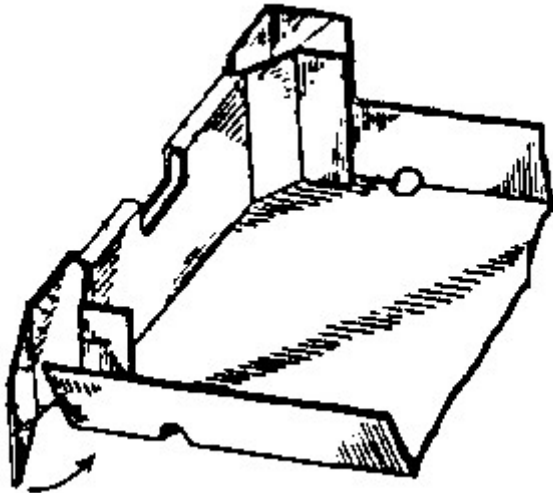

B65D 5/003

{having ledges formed by extensions of the side walls ([B65D 5/0045](#) and [B65D 5/0065](#) take precedence)}

Definition statement

This place covers:

Illustrative example of subject matter classified in this group:

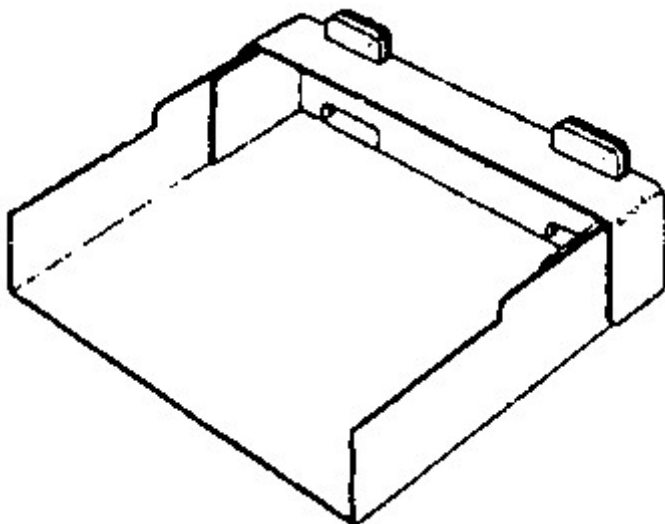

References

Limiting references

This place does not cover:

Having both integral corner posts and ledges	B65D 5/0045
Separate elements inserted in or attached to integral corner posts or ledges	B65D 5/0065

B65D 5/0035

{the ledges being located between side walls and doubled-over extensions
([B65D 5/0025](#) takes precedence)}

Definition statement

This place covers:

Illustrative example of subject matter classified in this group:

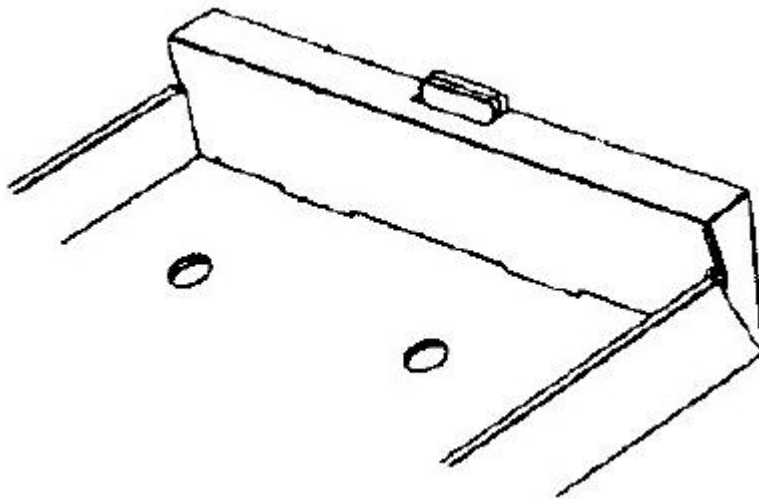

References

Limiting references

This place does not cover:

The corner posts being formed as a prolongation of a double-over extension of the side walls	B65D 5/0025
--	-----------------------------

B65D 5/004

{with separate means inserted between the doubled-over side walls for preventing lateral motion between stacked crates, i.e. the elements themselves not presenting stacking features, e.g. "n" shaped wires}

Definition statement

This place covers:

Illustrative example of subject matter classified in this group:

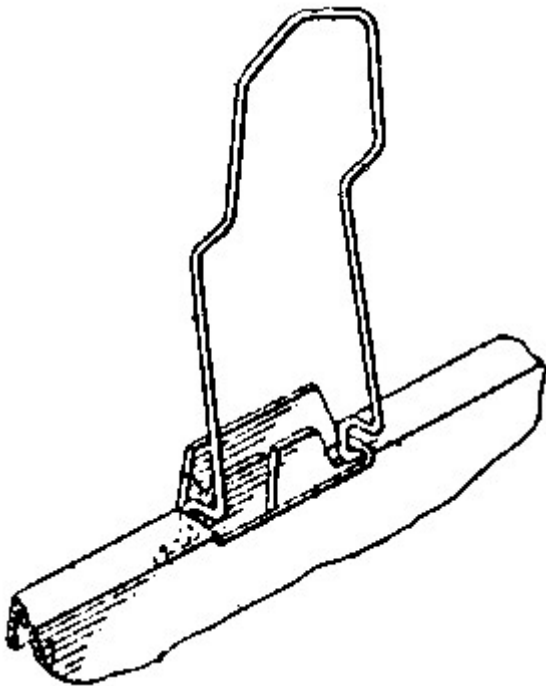

B65D 5/0045

{having both integral corner posts and ledges}

Definition statement

This place covers:

Illustrative example of subject matter classified in this group:

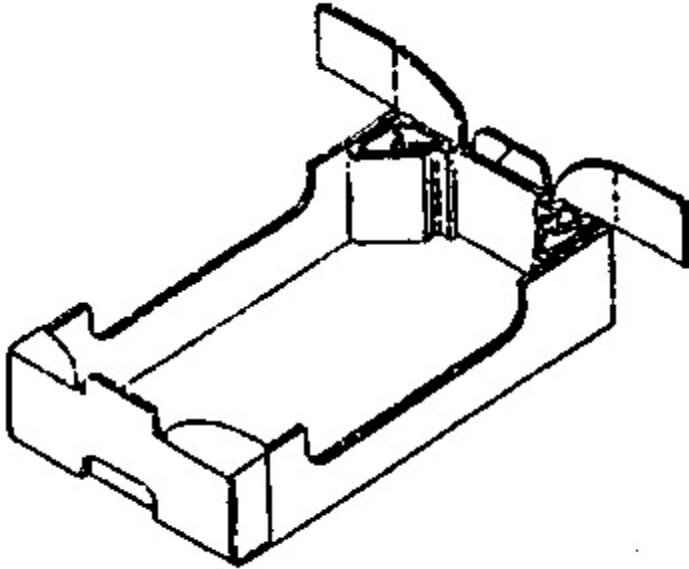

B65D 5/0055

{saddling the side walls of the container ([B65D 5/006](#) takes precedence)}

Definition statement

This place covers:

Illustrative example of subject matter classified in this group:

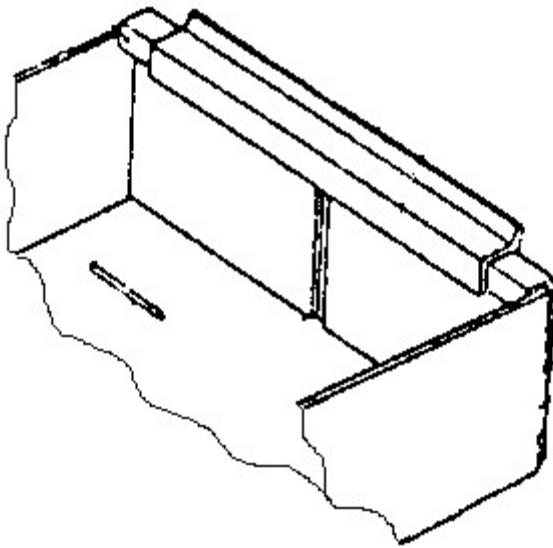

References

Limiting references

This place does not cover:

Separate corner posts and like elements	B65D 5/006
---	----------------------------

B65D 5/006

{Separate corner posts and like elements ([B65D 5/0065](#) takes precedence)}

Definition statement

This place covers:

Illustrative example of subject matter classified in this group:

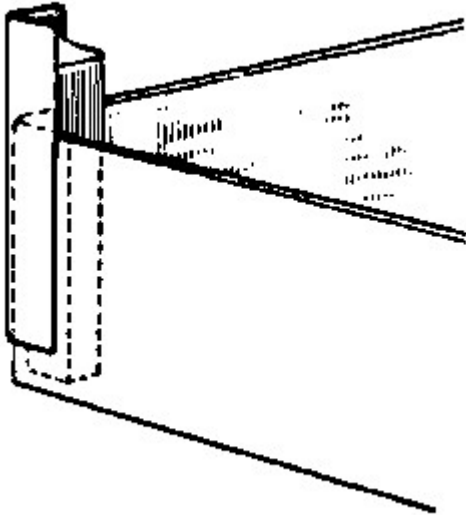
**References****Limiting references**

This place does not cover:

Separate elements inserted in or attached to integral corner posts or ledges	B65D 5/0065
--	-----------------------------

B65D 5/0065

{Separate elements inserted in or attached to integral corner posts or ledges}

Definition statement

This place covers:

Illustrative example of subject matter classified in this group:

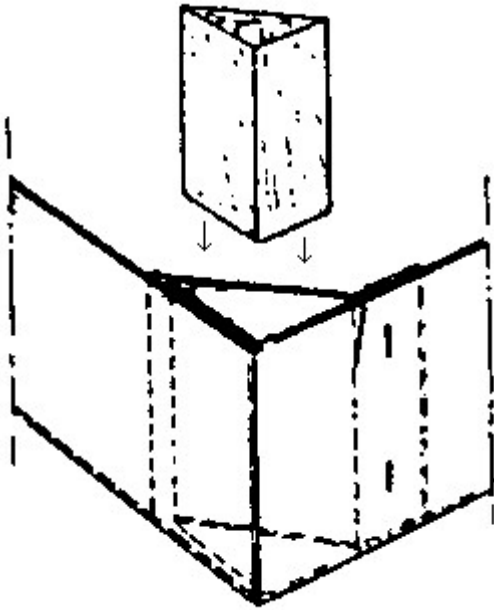

B65D 5/007

{Wooden elements affixed to the container blank before or during erection}

Definition statement

This place covers:

Illustrative example of subject matter classified in this group:

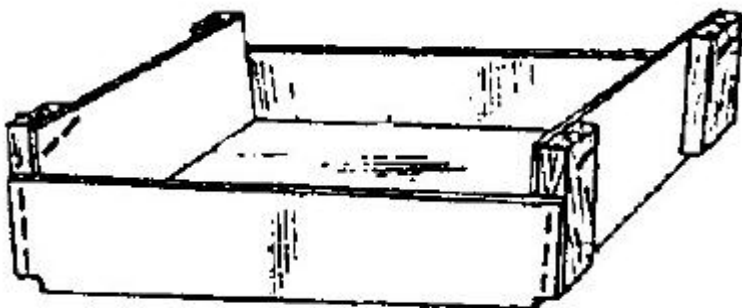

B65D 5/0075

{Paper elements affixed to the container blank before or during erection}

Definition statement

This place covers:

Illustrative example of subject matter classified in this group:

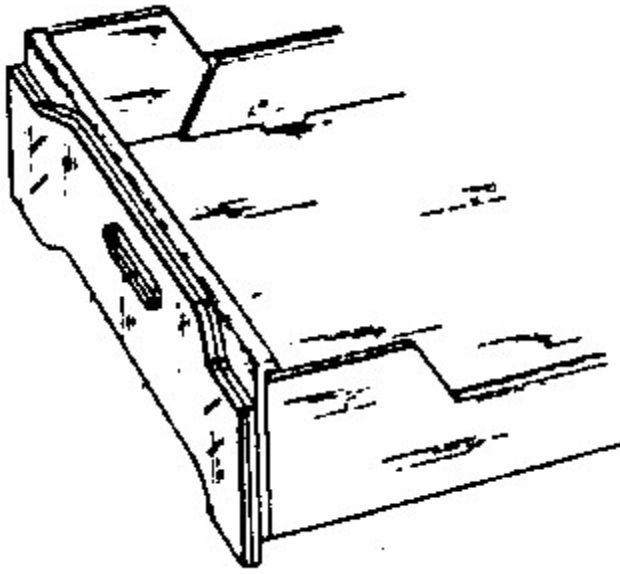

B65D 5/008

{the container body having a pyramidal shape}

Definition statement

This place covers:

Illustrative example of subject matter classified in this group:

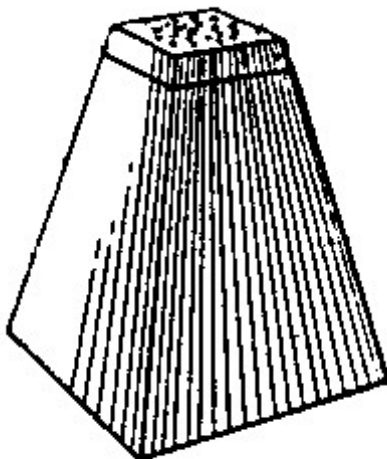

References

Informative references

Attention is drawn to the following places, which may be of interest for search:

Essentially conical or frusto-conical	B65D 3/06
The tubular body presenting a special shape	B65D 5/029
Tetrahedral packages	B65D 75/50

B65D 5/0085

{the container body comprising two mating compartments hinged together
([B65D 77/006](#) takes precedence)}

Definition statement

This place covers:

Illustrative example of subject matter classified in this group:

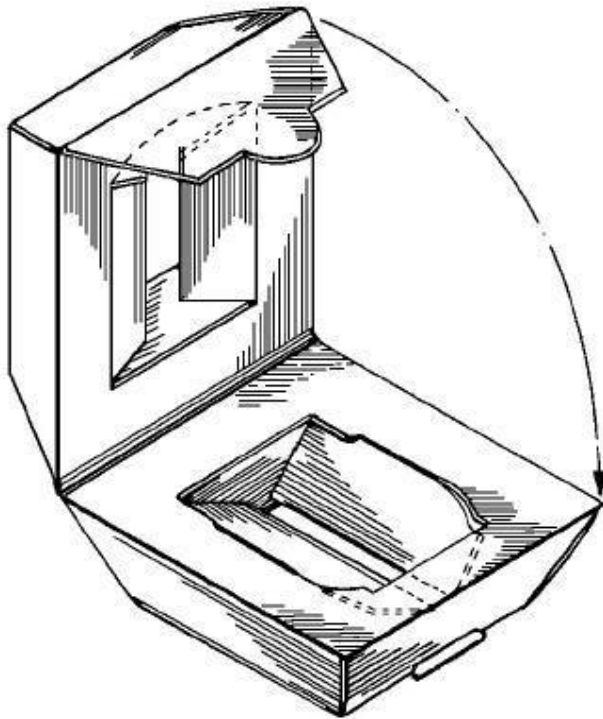

References

Limiting references

This place does not cover:

Containers simulating a book	B65D 77/006
------------------------------	-----------------------------

B65D 5/009

{the container body comprising a set of interconnected cells, e.g. hinged one to another}

Definition statement

This place covers:

Illustrative example of subject matter classified in this group:

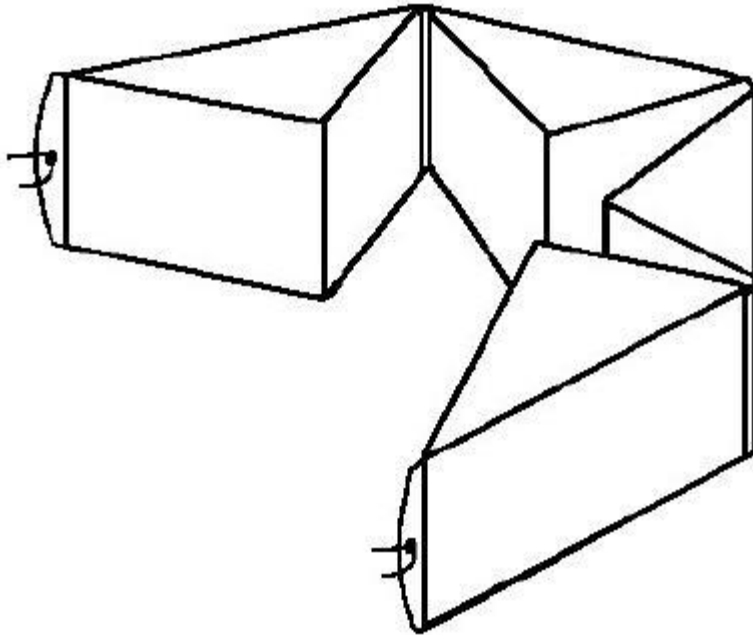

B65D 5/0095

{the container body having an L-shaped configuration}

Definition statement

This place covers:

Illustrative example of subject matter classified in this group:

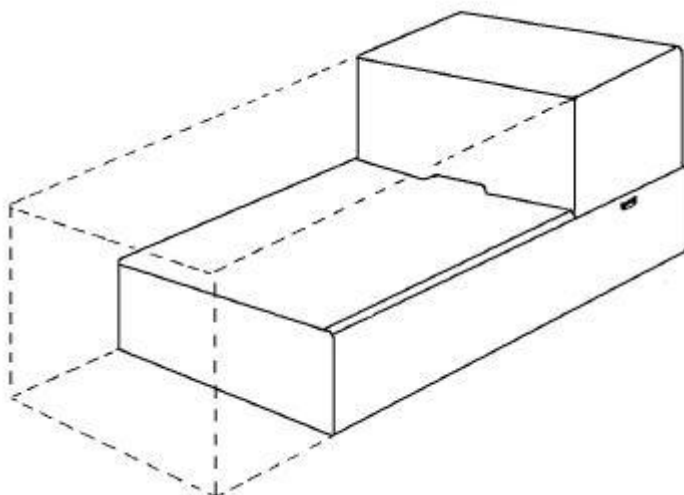

B65D 5/02

by folding or erecting a single blank to form a tubular body with or without subsequent folding operations, or the addition of separate elements, to close the ends of the body ([B65D 5/36](#) takes precedence)

References**Limiting references**

This place does not cover:

L-shaped boxes	B65D 5/0095
Specially constructed to allow collapsing and re-erecting without disengagement of side or bottom connections	B65D 5/36

B65D 5/0209

{the tubular body having a curved or partially curved cross-section}

Definition statement

This place covers:

Illustrative example of subject matter classified in this group:

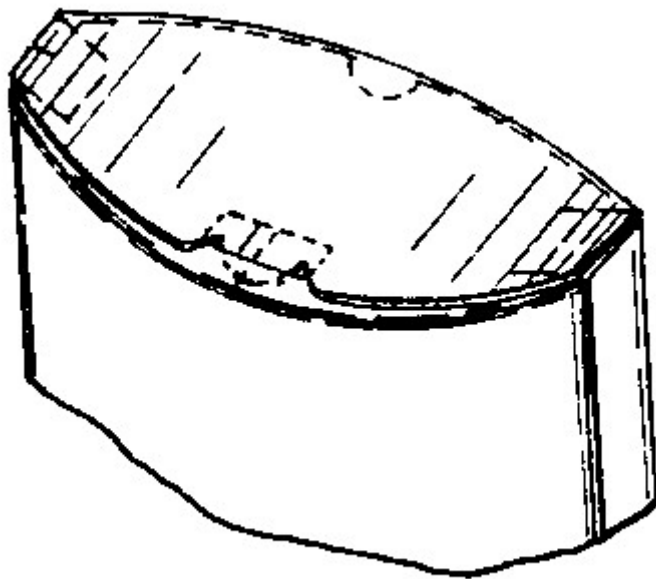
**References****Informative references**

Attention is drawn to the following places, which may be of interest for search:

Containers having bodies or peripheral walls of curved or partially curved cross-section made by winding or bending paper without folding along defined lines	B65D 3/00
---	---------------------------

Having a cross-section of varying shape	B65D 3/08
---	---------------------------

B65D 5/0218

{with end closures having an axially movable end wall; the end wall and body being interconnected by foldable panel-elements}

Definition statement

This place covers:

Illustrative example of subject matter classified in this group:

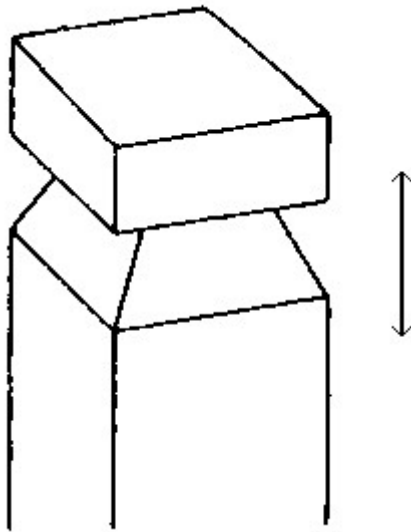

B65D 5/0227

{with end closures formed by inward folding of flaps and securing them by heat-sealing, by applying adhesive to the flaps or by staples}

Definition statement

This place covers:

Illustrative example of subject matter classified in this group:

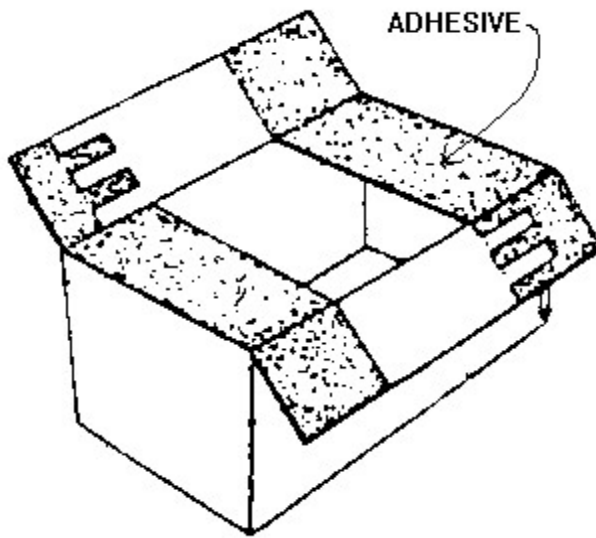

B65D 5/0236

{with end closures formed by inward folding of flaps and securing them by adhesive tapes, labels or the like; for decoration purposes ([B65D 5/4245](#), [B65D 5/4262](#) take precedence)}

Definition statement

This place covers:

Illustrative example of subject matter classified in this group:

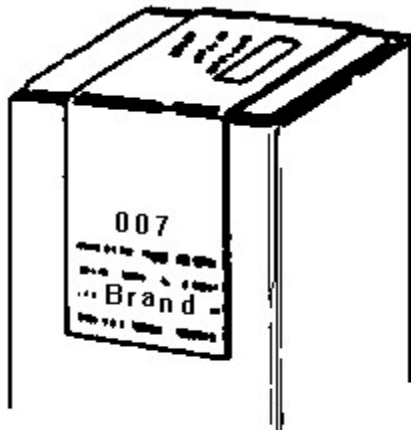
**References****Limiting references**

This place does not cover:

Bands covering at least 3 adjacent faces of a container	B65D 5/4245
Bands covering at least 3 adjacent faces of a container provided with a decoration	B65D 5/4262

Informative references

Attention is drawn to the following places, which may be of interest for search:

The lid being held in closed position by application of separate elements	B65D 5/6611
---	-----------------------------

B65D 5/0245

{with end closures formed by inward folding of flaps, to form a sunken or hollow end wall, e.g. for the packaging of books (internal supporting elements [B65D 5/50](#))}

Definition statement

This place covers:

Illustrative example of subject matter classified in this group:

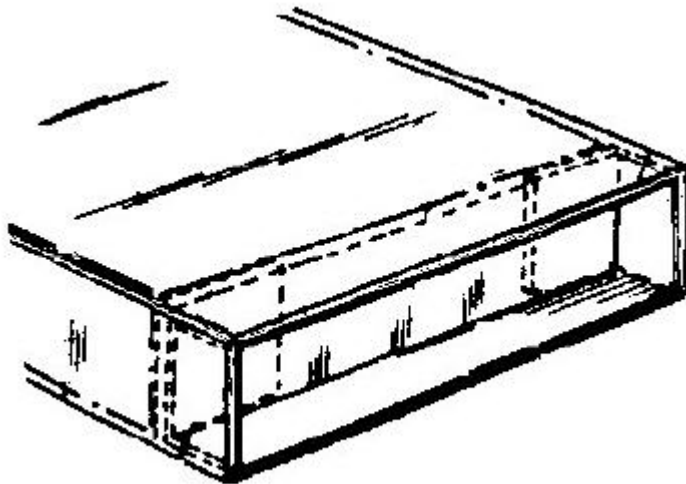
**References****Informative references**

Attention is drawn to the following places, which may be of interest for search:

Articles or materials wholly enclosed in single sheets or wrapper blanks	B65D 75/04
In sheets or blanks folded-up around all sides of the contents from a portion on which the contents are placed	B65D 75/14

B65D 5/0254

{with end closures formed by inward folding of flaps and securing them by means of a tongue integral with one of the flaps}

Definition statement

This place covers:

Illustrative example of subject matter classified in this group:

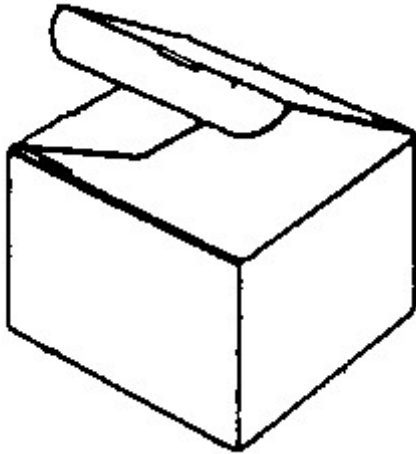
**References****Informative references**

Attention is drawn to the following places, which may be of interest for search:

With end closures formed by inward-folding of self-locking flaps hinged to tubular body	B65D 5/10
Formed by folding one or more extensions hinged to the upper edge of a tubular container body	B65D 5/6602

B65D 5/0263

{with end closures formed by inward folding of flaps, three of them being formed of a continuous strip, the fourth being a separate flap}

Definition statement

This place covers:

Illustrative example of subject matter classified in this group:

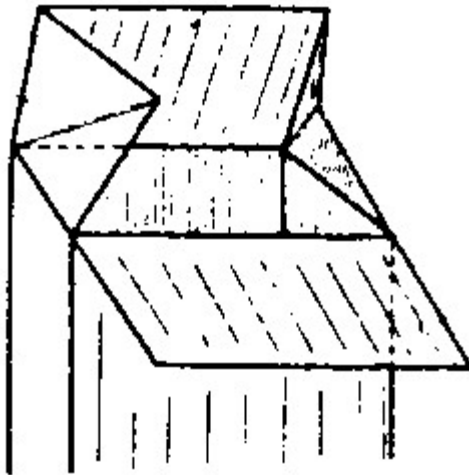

B65D 5/0272

{with end closures formed by applying a web on the edge of the body, and subsequent inward folding of flaps}

Definition statement

This place covers:

Illustrative example of subject matter classified in this group:

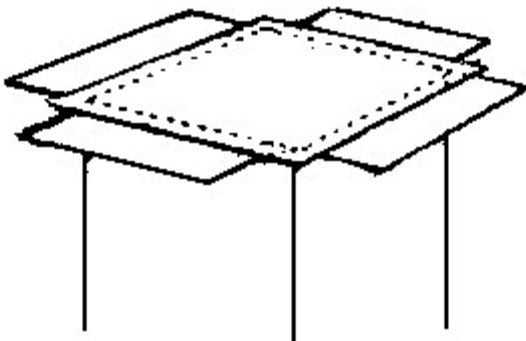

B65D 5/0281

{the tubular body presenting double or multiple walls (for thermal insulating purposes [B65D 81/3853](#))}

Definition statement

This place covers:

Illustrative example of subject matter classified in this group:

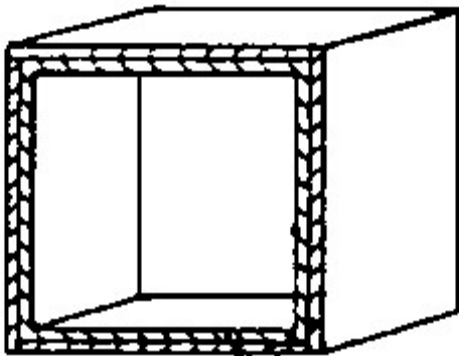
**B65D 5/029**

{the tubular body presenting a special shape (pyramidal [B65D 5/008](#))}

Definition statement

This place covers:

Illustrative example of subject matter classified in this group:

**References****Limiting references**

This place does not cover:

L-shaped boxes	B65D 5/0095
----------------	-----------------------------

Informative references

Attention is drawn to the following places, which may be of interest for search:

Having a cross-section of varying shape	B65D 3/08
The tubular body having a curved or partially curved cross-section	B65D 5/0209

B65D 5/04

the tubular body having no end closures

Definition statement

This place covers:

Illustrative example of subject matter classified in this group:

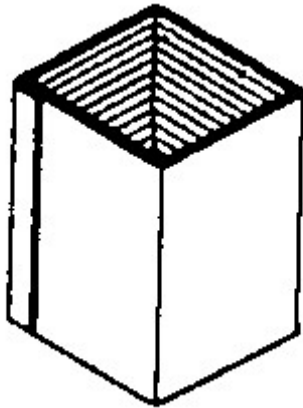
**References****Informative references**

Attention is drawn to the following places, which may be of interest for search:

Shell of drawer-and-shell type containers	B65D 5/38
---	---------------------------

B65D 5/061

{Rectangular containers having a body with gusset-flaps folded inwardly beneath the closure flaps}

Definition statement

This place covers:

Illustrative example of subject matter classified in this group:

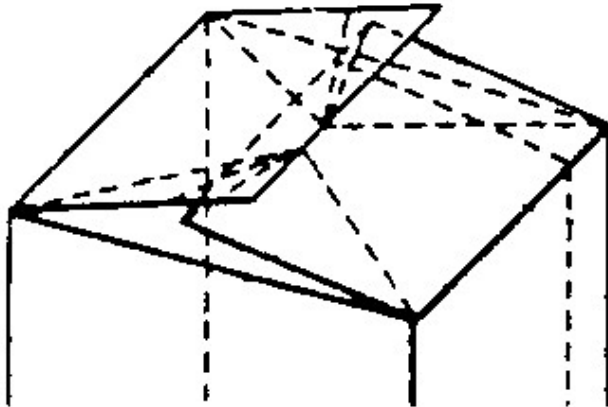
**B65D 5/063**

{with supplemental clamping elements mounted on the container top}

References***Informative references***

Attention is drawn to the following places, which may be of interest for search:

With supplemental clamping elements mounted on the container top	B65D 5/066
With supplemental clamping elements mounted on the fin of the container-top	B65D 5/069

B65D 5/064

{Rectangular containers having a body with gusset-flaps folded outwardly or adhered to the side or the top of the container}

Definition statement

This place covers:

Illustrative example of subject matter classified in this group:

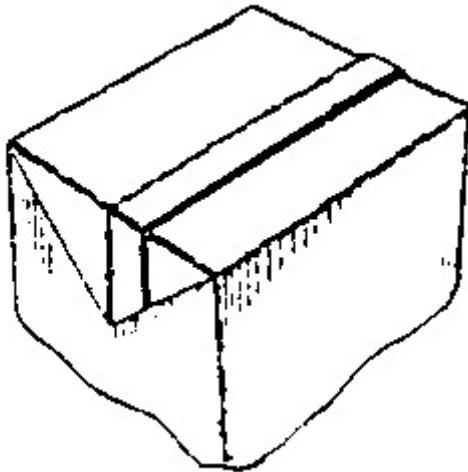
**B65D 5/066**

{with supplemental clamping elements mounted on the container top}

References***Informative references***

Attention is drawn to the following places, which may be of interest for search:

With supplemental clamping elements mounted on the container top	B65D 5/063
With supplemental clamping elements mounted on the fin of the container-top	B65D 5/069

B65D 5/067**{Gable-top containers}****Definition statement***This place covers:*

Illustrative example of subject matter classified in this group:

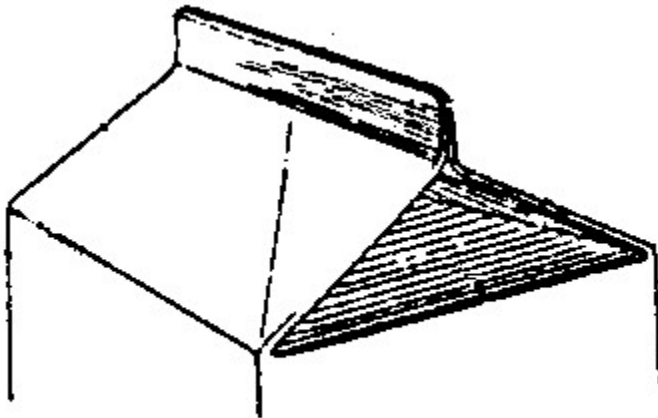
**B65D 5/069****{with supplemental clamping elements mounted on the fin of the container-top}****References*****Informative references****Attention is drawn to the following places, which may be of interest for search:*

Rectangular containers having a body with gusset-flaps folded inwardly beneath the closure flaps with supplemental clamping elements mounted on the container top	B65D 5/063
Rectangular containers having a body with gusset-flaps folded outwardly or adhered to the side or the top of the container with supplemental clamping elements mounted on the container top	B65D 5/066

B65D 5/08

with end closures formed by inward-folding of portions of body, e.g. flaps, interconnected by, or incorporating, gusset folds (by inward-folding of a wall extending continuously around an end of the body and incorporating gusset folds [B65D 5/06](#))

Definition statement

This place covers:

Illustrative example of subject matter classified in this group:

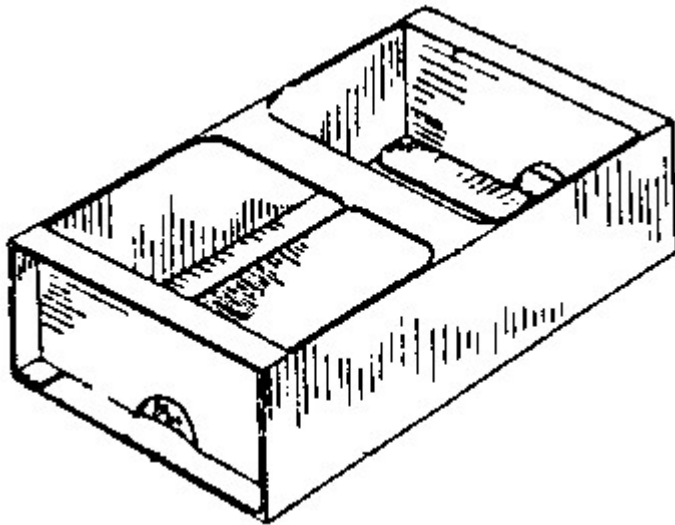

References

Informative references

Attention is drawn to the following places, which may be of interest for search:

The container body having hollow side-walls	B65D 5/2004
Integral elements for containers having tubular body walls formed by openings in the body walls	B65D 5/5019

B65D 5/10

with end closures formed by inward-folding of self-locking flaps hinged to tubular body

References

Informative references

Attention is drawn to the following places, which may be of interest for search:

With end closures formed by inward folding of flaps and securing means of them by means of a tongue integral with one of the flaps	B65D 5/0254
Formed by folding inwardly of extensions hinged to the upper or lower edges of the body	B65D 5/5011
Sleeves	B65D 59/04

B65D 5/106

{the opening being a slot}

Definition statement

This place covers:

Illustrative example of subject matter classified in this group:

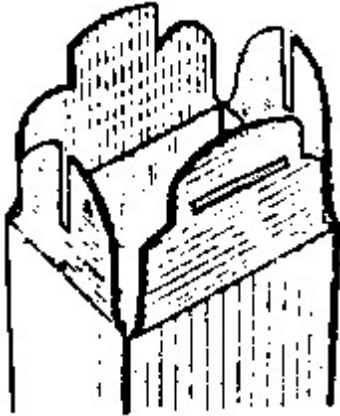

B65D 5/12

with end closures formed separately from tubular body

Definition statement

This place covers:

Illustrative example of subject matter classified in this group:

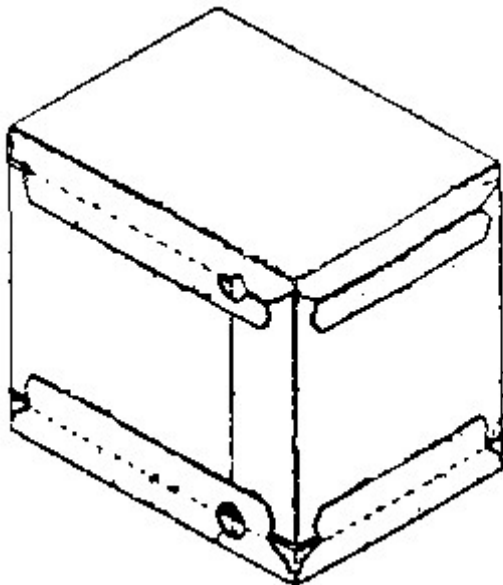

References

Informative references

Attention is drawn to the following places, which may be of interest for search:

Having bodies formed by folding and interconnecting two or more blanks, each blank forming a body part, whereby each body part comprises at least one outside face of the box, carton or tray	B65D 5/32
---	---------------------------

B65D 5/14

with inset end closures

Definition statement

This place covers:

Illustrative example of subject matter classified in this group:

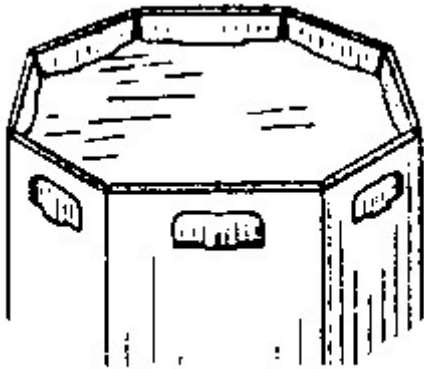

B65D 5/16

the tubular body being formed with an aperture or removable portion arranged to allow removal or insertion of contents through one or more sides (contents-dispensing means [B65D 5/72](#))

Definition statement

This place covers:

Illustrative example of subject matter classified in this group:

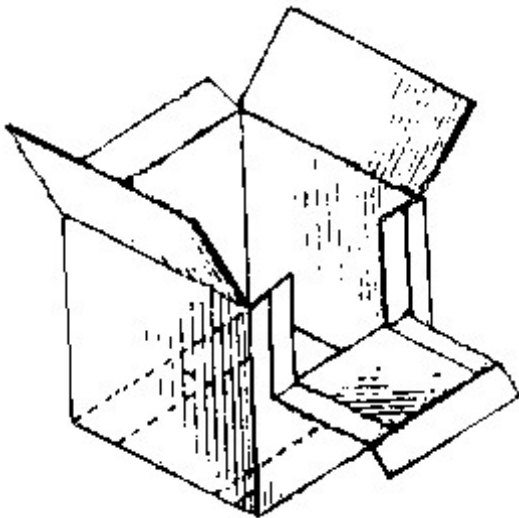
**B65D 5/18**

by folding a single blank to U-shape to form the base of the container and opposite sides of the body portion, the remaining sides being formed primarily by extensions of one or more of these opposite sides, e.g. flaps hinged thereto ([B65D 5/36](#) takes precedence)

References**Limiting references**

This place does not cover:

Specially constructed to allow collapsing and re-erecting without disengagement of side or bottom connections	B65D 5/36
Bags	B65D 31/005

B65D 5/20

by folding-up portions connected to a central panel from all sides to form a container body, e.g. of tray-like form ([B65D 5/36](#) takes precedence)

References**Limiting references**

This place does not cover:

Specially constructed to allow collapsing and re-erecting without disengagement of side or bottom connections	B65D 5/36
---	---------------------------

B65D 5/2004

{the container body having hollow side-walls}

References**Informative references**

Attention is drawn to the following places, which may be of interest for search:

With end closures formed by inward-folding of portions of body	B65D 5/08
Racks having upstanding ridges formed by folds, and provided with slits or recesses	B65D 5/504

B65D 5/2009

{all formed by folding extensions of the side walls}

Definition statement

This place covers:

Illustrative example of subject matter classified in this group:

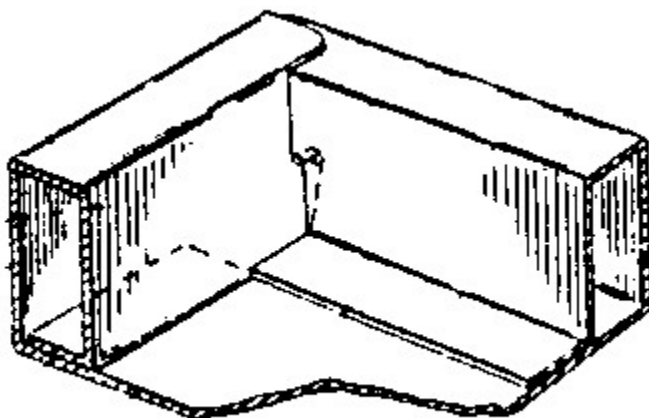

References

Limiting references

This place does not cover:

Combined with hollow side-walls formed by inwardly cut portions of one body panel	B65D 5/2004
---	-----------------------------

B65D 5/2014

{the central panel having a non rectangular shape}

Definition statement

This place covers:

Illustrative example of subject matter classified in this group:

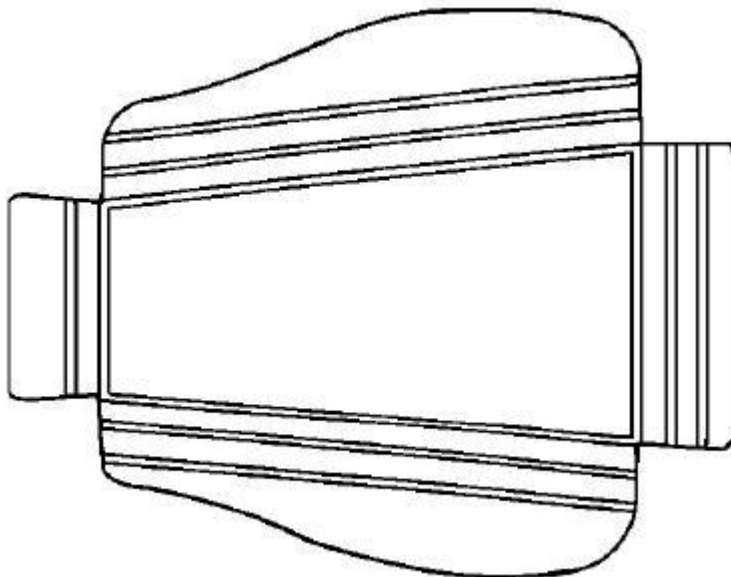

References

Limiting references

This place does not cover:

Triangular	B65D 5/2042
Trapezoidal	B65D 5/2047

B65D 5/2019

{with at least partially curved edges or the like}

Definition statement

This place covers:

Illustrative example of subject matter classified in this group:

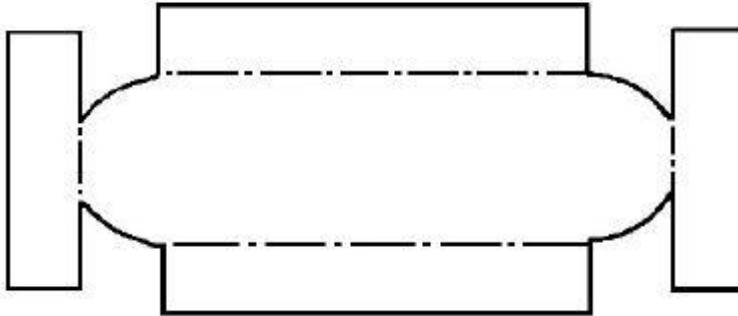

B65D 5/2023

{the folded-up portions being folded along non-rectilinear fold-lines}

Definition statement

This place covers:

Illustrative example of subject matter classified in this group:

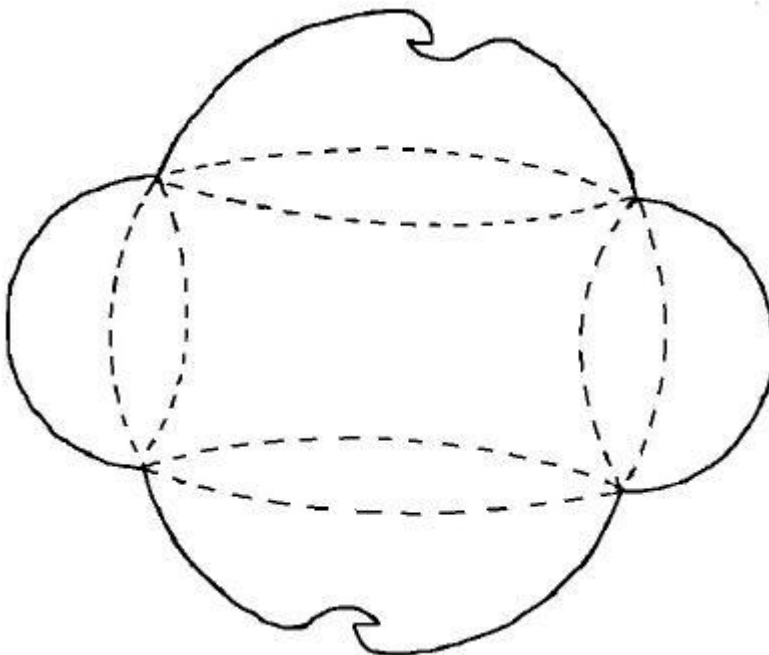

B65D 5/2028

{triangular}

Definition statement

This place covers:

Illustrative example of subject matter classified in this group:

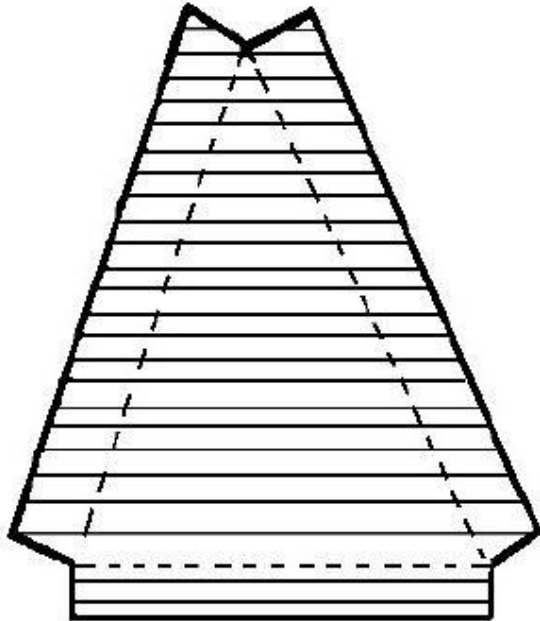

B65D 5/2033

{polygonal having more than four sides, e.g. hexagonal, octagonal}

Definition statement

This place covers:

Illustrative example of subject matter classified in this group:

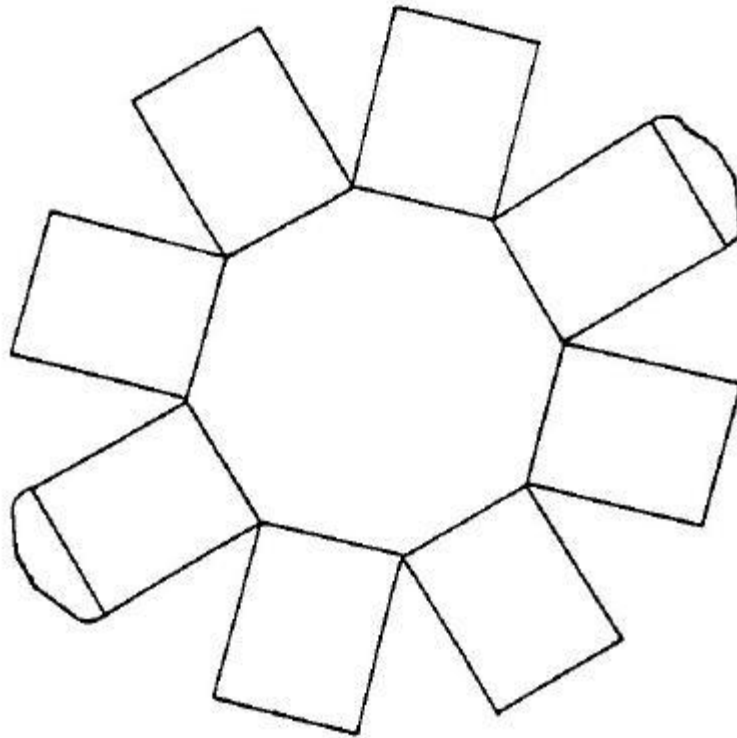

B65D 5/2038

{at least two opposed folded-up portions having a non-rectangular shape}

Definition statement

This place covers:

Illustrative example of subject matter classified in this group:

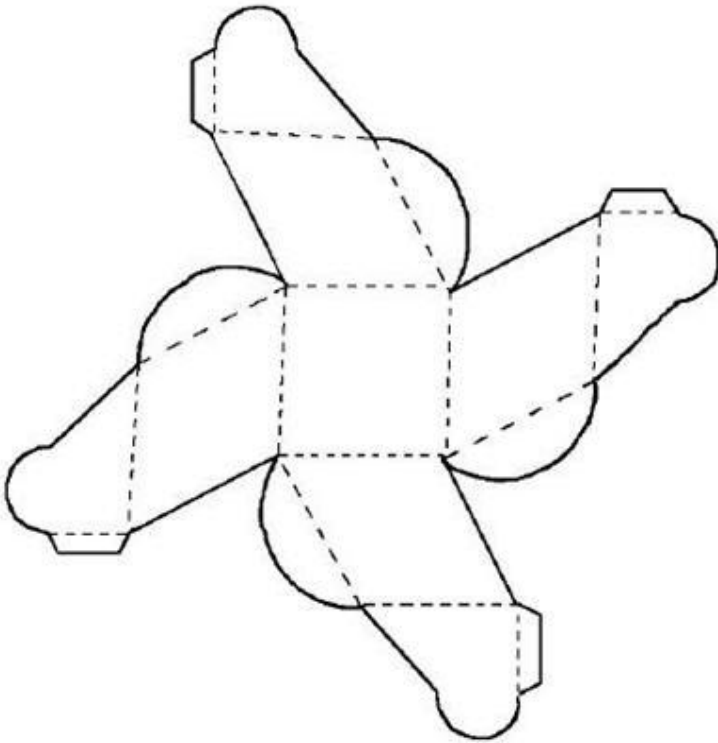

B65D 5/2042

{triangular}

Definition statement

This place covers:

Illustrative example of subject matter classified in this group:

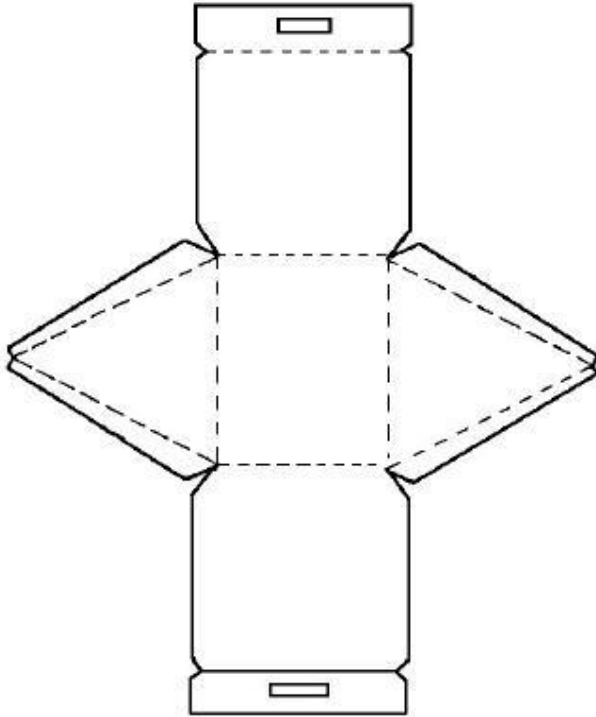

B65D 5/2047

{trapezoidal, e.g. to form a body with diverging side walls ([B65D 5/2033](#) takes precedence)}

Definition statement

This place covers:

Illustrative example of subject matter classified in this group:

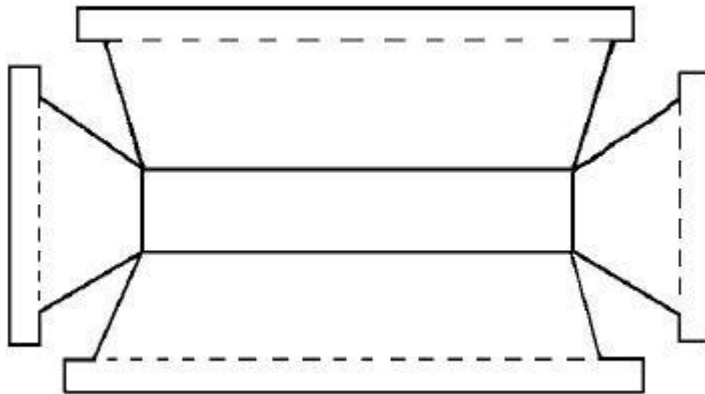
**References****Limiting references**

This place does not cover:

Polygonal having more than four sides	B65D 5/2033
---------------------------------------	-----------------------------

B65D 5/2052

{characterised by integral closure-flaps}

References**Informative references**

Attention is drawn to the following places, which may be of interest for search:

Articles or materials wholly enclosed in sheets or blanks folded-up around all sides of the contents from a portion on which the contents are placed	B65D 75/14
--	----------------------------

B65D 5/2057

{Inter-engaging self-locking flaps ([B65D 5/4254](#) takes precedence)}

Definition statement

This place covers:

Illustrative example of subject matter classified in this group:

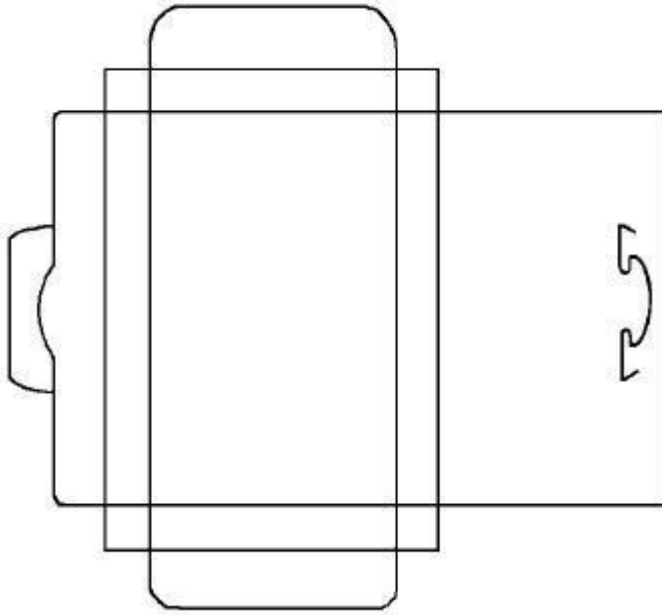

References

Limiting references

This place does not cover:

Decoration elements formed by two or mating closure panels	B65D 5/4254
--	-----------------------------

B65D 5/2061

{of triangular shape}

Definition statement

This place covers:

Illustrative example of subject matter classified in this group:

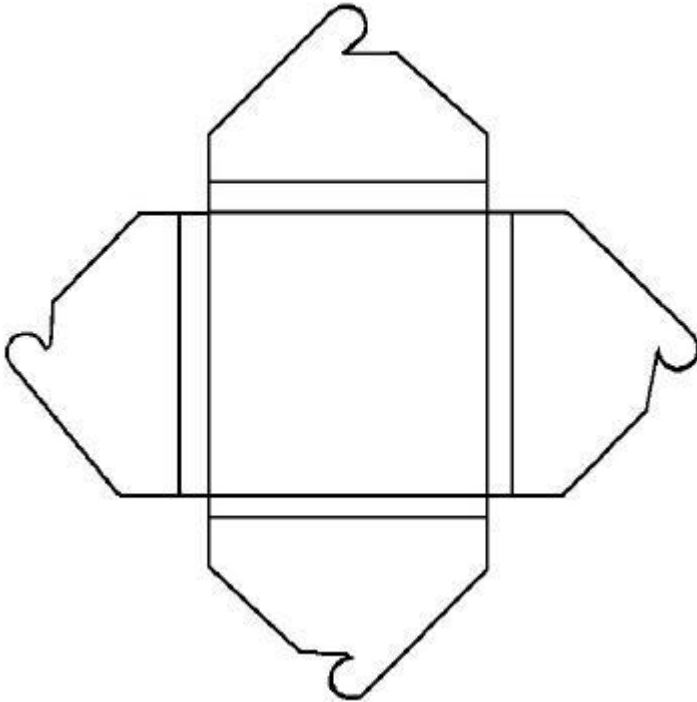

References

Limiting references

This place does not cover:

Combined with handles	B65D 5/46136
-----------------------	------------------------------

B65D 5/2066

{Cooperating flaps fixed together by separate mechanical elements, e.g. staples, clips, straps, labels, tape}

Definition statement

This place covers:

Illustrative example of subject matter classified in this group:

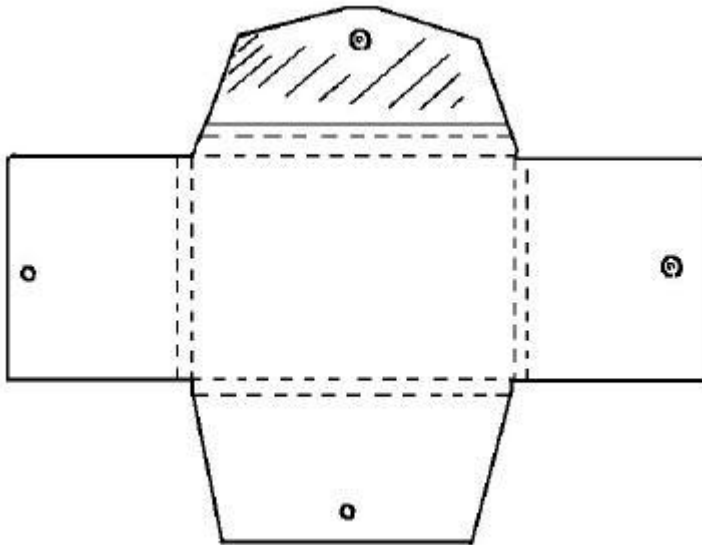

B65D 5/2071

{of triangular shape}

Definition statement

This place covers:

Illustrative example of subject matter classified in this group:

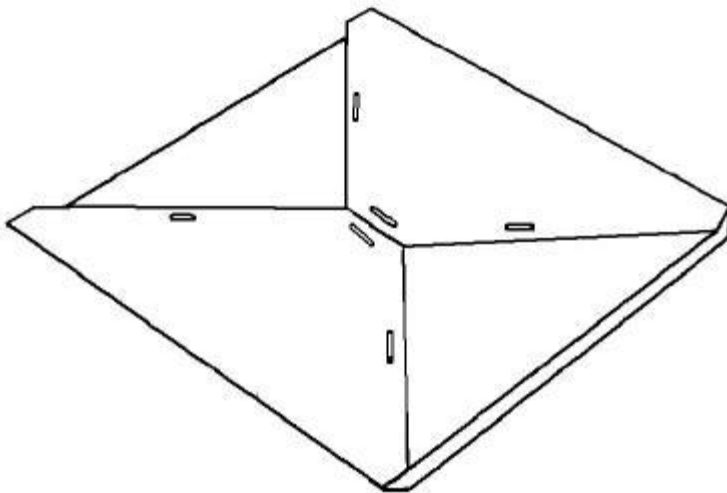

B65D 5/2076

{Cooperating flaps glued together}

Definition statement

This place covers:

Illustrative example of subject matter classified in this group:

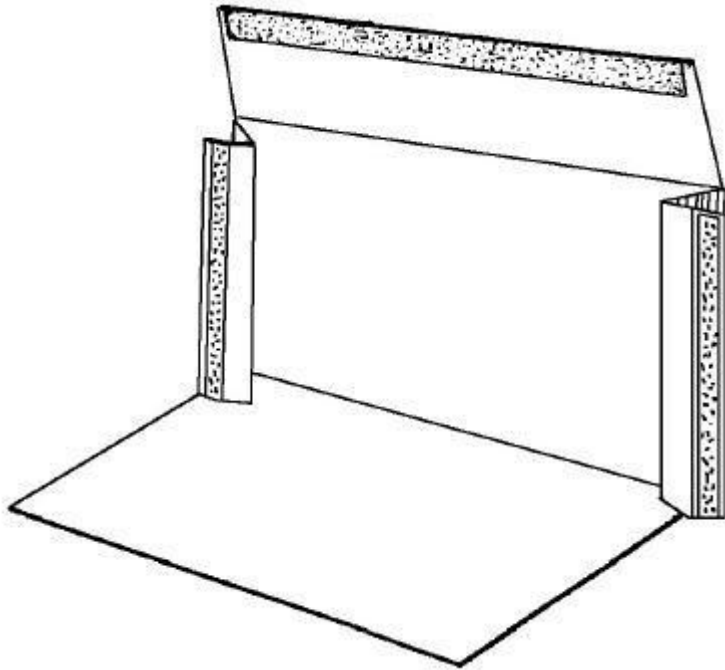

B65D 5/208

{of triangular shape}

Definition statement

This place covers:

Illustrative example of subject matter classified in this group:

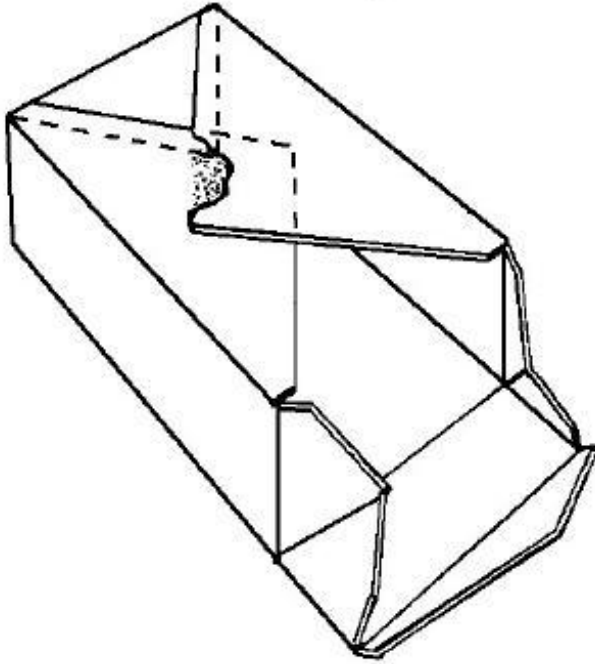

B65D 5/2085

{the central panel having incisions defining foldable flaps hinged to its edges}

Definition statement

This place covers:

Illustrative example of subject matter classified in this group:

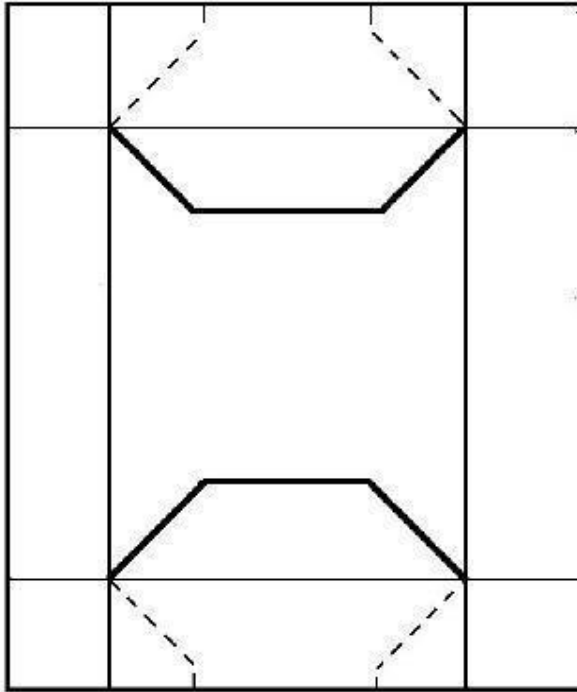

B65D 5/209

{the adjacent edges of folded-up portions being joined by moulding seams in situ}

Definition statement

This place covers:

Illustrative example of subject matter classified in this group:

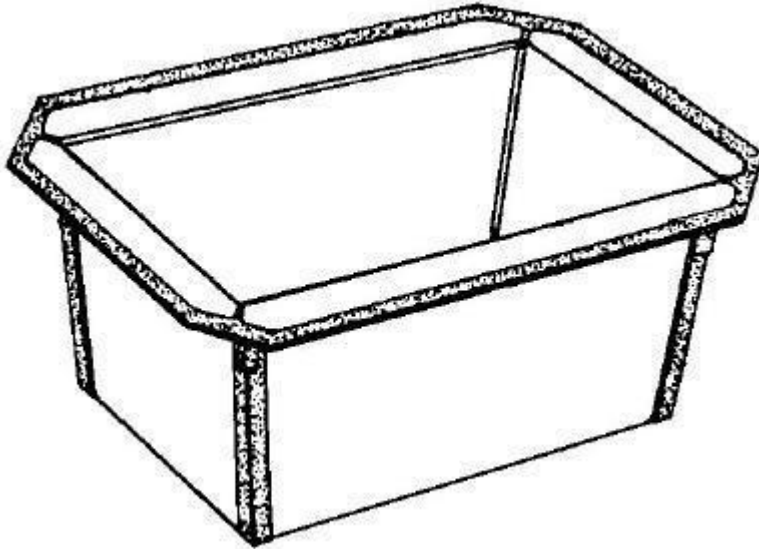
**References*****Informative references***

Attention is drawn to the following places, which may be of interest for search:

Joining juxtaposed parts of a single article	B29C 45/14475
--	-------------------------------

B65D 5/2095

{a part of the folded-up portions defining an inwardly folded ledge at the edges of the central panel}

Definition statement

This place covers:

Illustrative example of subject matter classified in this group:

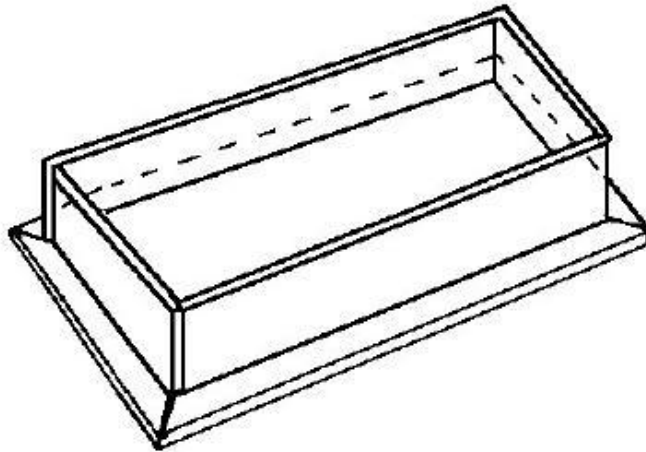

B65D 5/22

held erect by extensions of one or more sides being doubled-over to enclose extensions of adjacent sides

Definition statement

This place covers:

Illustrative example of subject matter classified in this group:

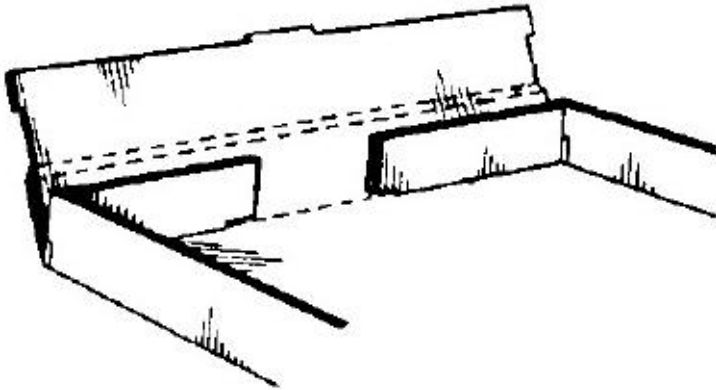

References

Limiting references

This place does not cover:

The extensions of one or more sides being doubled-over to enclose extensions of adjacent sides	B65D 5/365
--	----------------------------

B65D 5/24

with adjacent sides interconnected by gusset folds

Definition statement

This place covers:

Illustrative example of subject matter classified in this group:

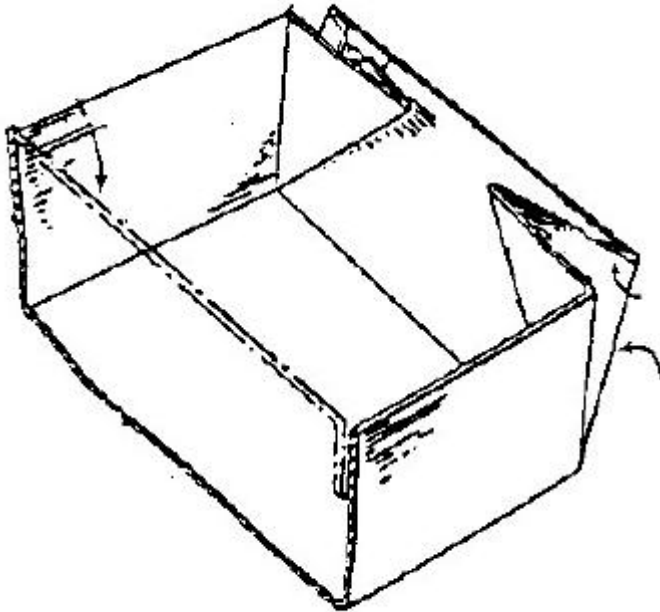
**References****Limiting references**

This place does not cover:

The adjacent sides being interconnected by gusset folds	B65D 5/3657
The container being formed by folding-up portions connected to a central panel from all sides, adjacent sides being interconnected by gusset folds and the container being maintained in erected condition by means of the separate connectors coacting with the gusset folds	B65D 5/4287

B65D 5/241

{and the gussets folds connected to the inside of the container body
([B65D 5/247](#) and [B65D 5/248](#) take precedence)}

Definition statement

This place covers:

Illustrative example of subject matter classified in this group:

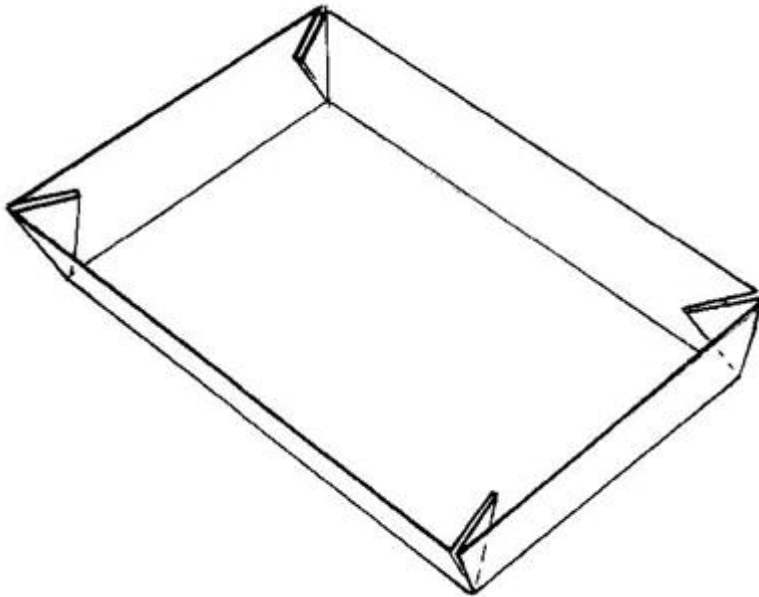
**References****Limiting references**

This place does not cover:

Being maintained in erected condition by integral mechanical locking means formed on, or coacting with, the gusset folds	B65D 5/247
At least one side being extended and doubled-over to enclose the adjacent gusset flaps	B65D 5/248

B65D 5/242

{the gussets folds comprising more than two gusset panels}

Definition statement

This place covers:

Illustrative example of subject matter classified in this group:

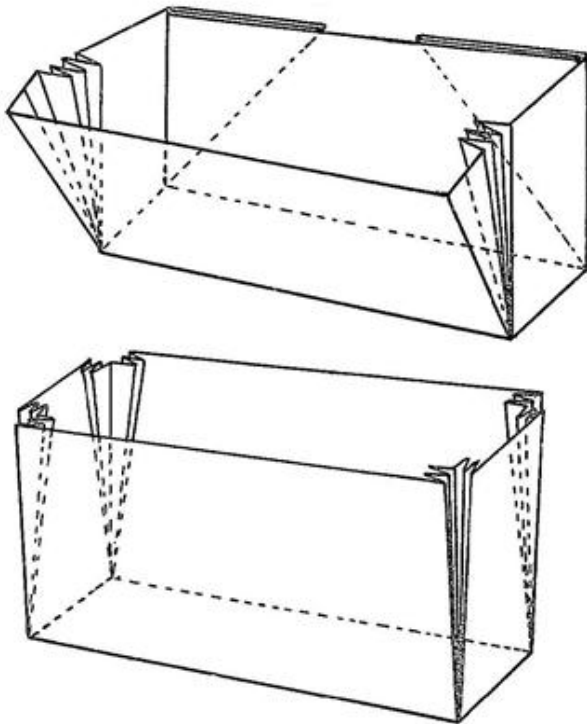

B65D 5/243

{the container body comprising a continuous rim or flange}

Definition statement

This place covers:

Illustrative example of subject matter classified in this group:

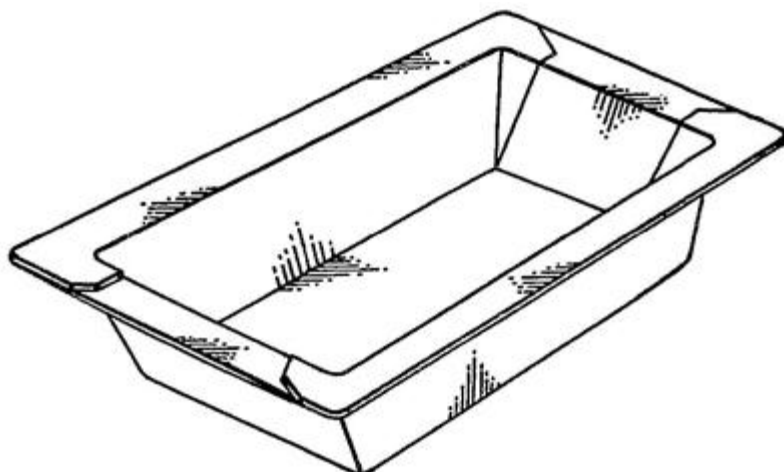

B65D 5/244

{and the gussets folds connected to the outside of the container body
([B65D 5/247](#), [B65D 5/248](#) take precedence)}

Definition statement

This place covers:

Illustrative example of subject matter classified in this group:

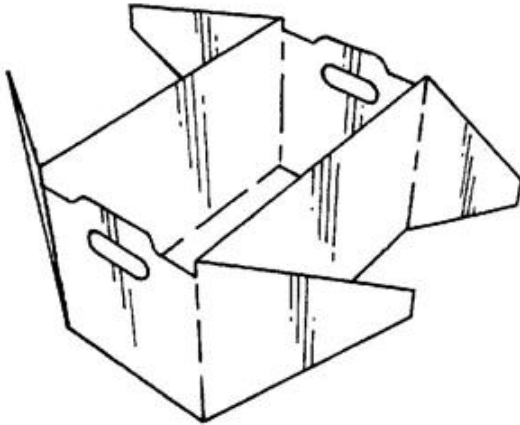
**References*****Limiting references***

This place does not cover:

Being maintained in erected condition by integral mechanical locking means formed on, or coating with, the gusset folds	B65D 5/247
At least one side being extended and doubled-over to enclose the adjacent gusset flaps	B65D 5/248

B65D 5/245

{the gussets folds comprising more than two gusset panels}

Definition statement

This place covers:

Illustrative example of subject matter classified in this group:

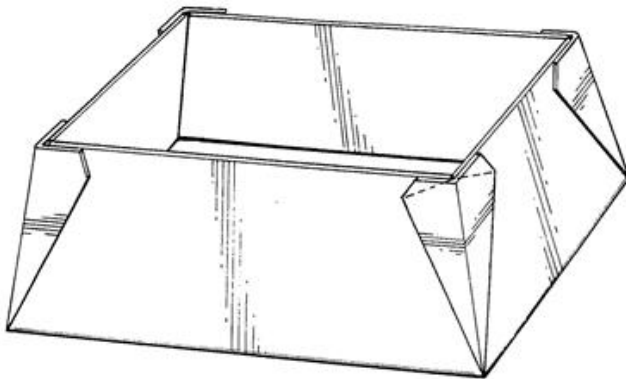

B65D 5/246

{the container body comprising a continuous rim or flange}

Definition statement

This place covers:

Illustrative example of subject matter classified in this group:

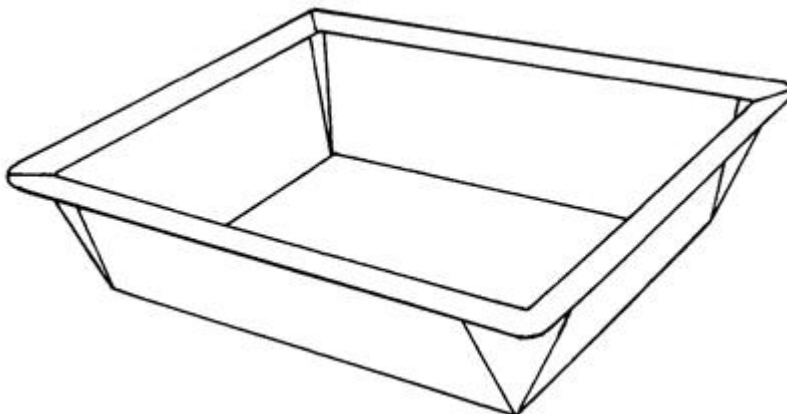

B65D 5/247

{and being maintained in erected condition by integral mechanical locking means formed on, or coacting with, the gusset folds, e.g. locking tabs, tongue and slit ([B65D 5/248](#) takes precedence)}

Definition statement

This place covers:

Illustrative example of subject matter classified in this group:

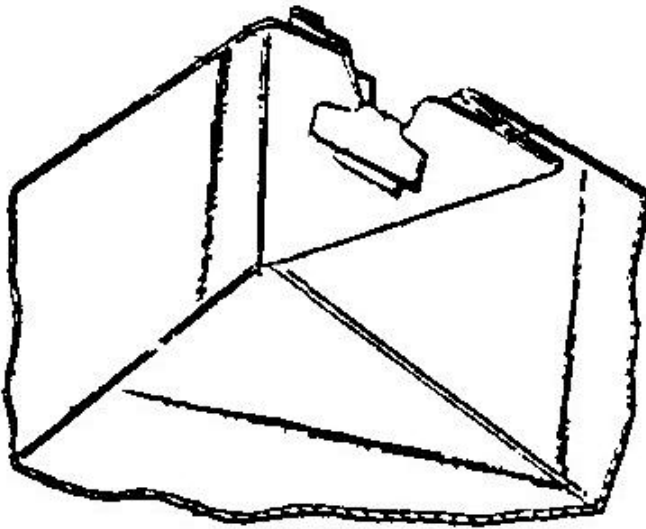

B65D 5/248

{and at least one side being extended and doubled-over to enclose the adjacent gusset flaps}

Definition statement

This place covers:

Illustrative example of subject matter classified in this group:

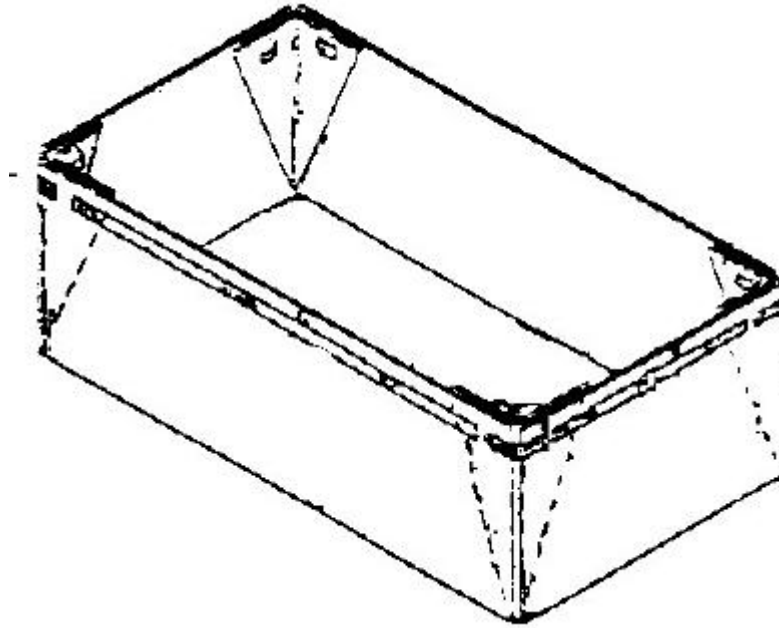
**References****Limiting references**

This place does not cover:

Side walls having a substantial thickness for stacking purposes	B65D 5/0035
Hollow side walls	B65D 5/0035 , B65D 5/2004

B65D 5/26

with extensions of opposite sides mutually interlocking to lie against other sides

Definition statement

This place covers:

Illustrative example of subject matter classified in this group:

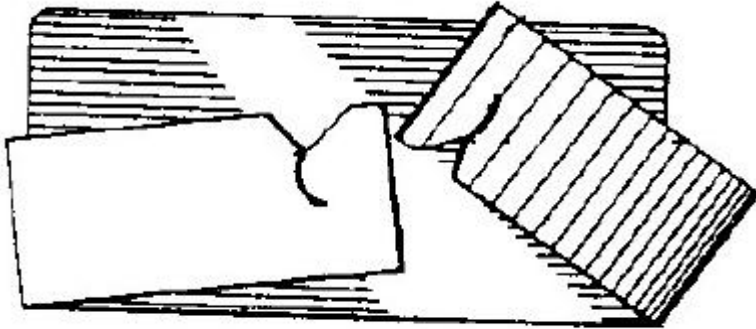

B65D 5/28

with extensions of sides permanently secured to adjacent sides, with sides permanently secured together by adhesive strips, or with sides held in place solely by rigidity of material

Definition statement

This place covers:

Illustrative example of subject matter classified in this group:

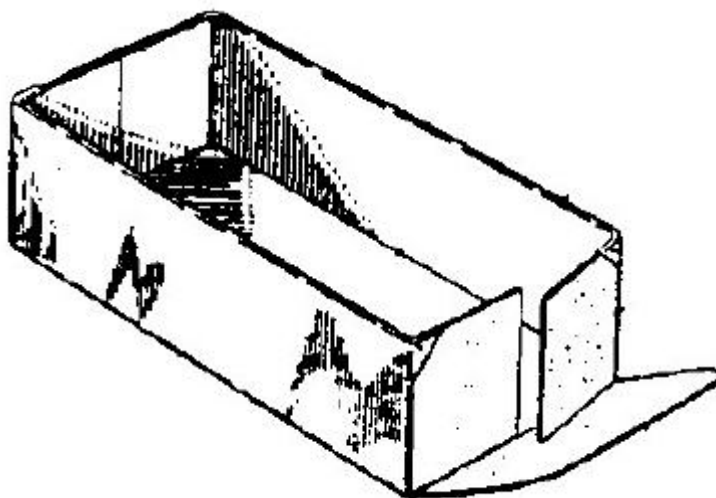

B65D 5/30

with tongue-and-slot or like connections between sides and extensions of other sides

Definition statement

This place covers:

Illustrative example of subject matter classified in this group:

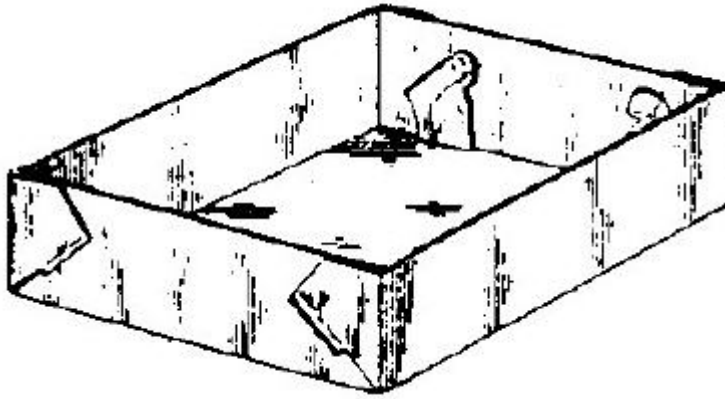

References

Informative references

Attention is drawn to the following places, which may be of interest for search:

Joints, seams, leakproof joints or corners, special connections between panels	B65D 5/4279
--	-----------------------------

B65D 5/302

{combined with a slot provided in an adjacent side wall}

Definition statement

This place covers:

Illustrative example of subject matter classified in this group:

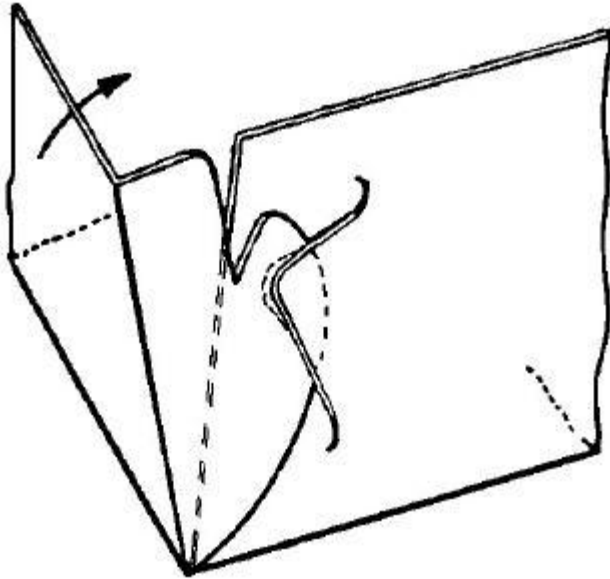

B65D 5/304

{the tongue being folded over after being introduced in the slot}

Definition statement

This place covers:

Illustrative example of subject matter classified in this group:

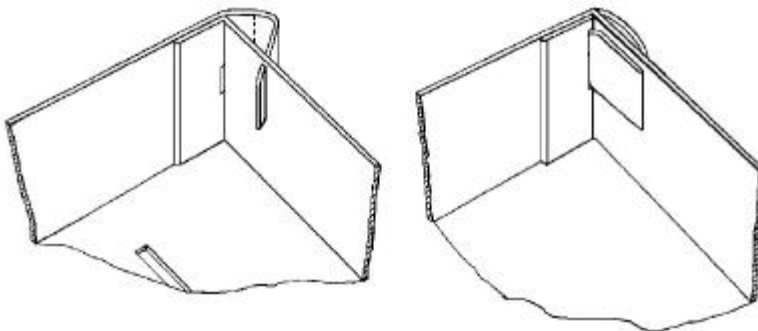

B65D 5/305

{combined with a slot provided at the fold line between an adjacent side wall and a lateral extension thereof}

Definition statement

This place covers:

Illustrative example of subject matter classified in this group:

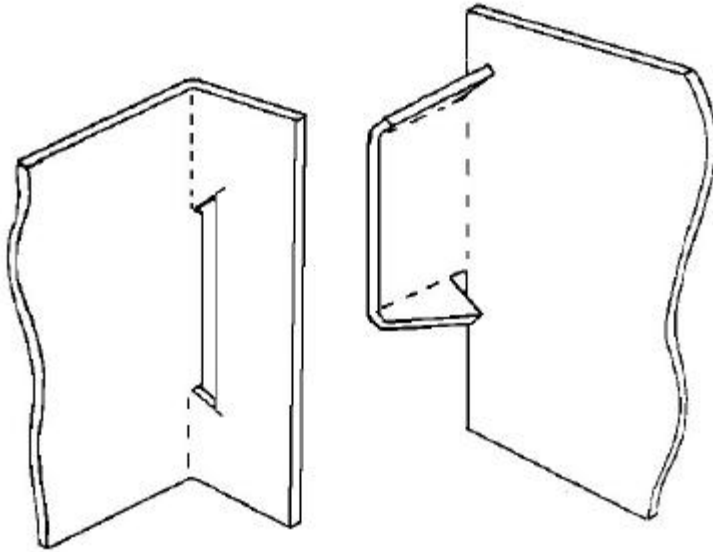

B65D 5/307

{combined with a tongue provided in an adjacent side wall}

Definition statement

This place covers:

Illustrative example of subject matter classified in this group:

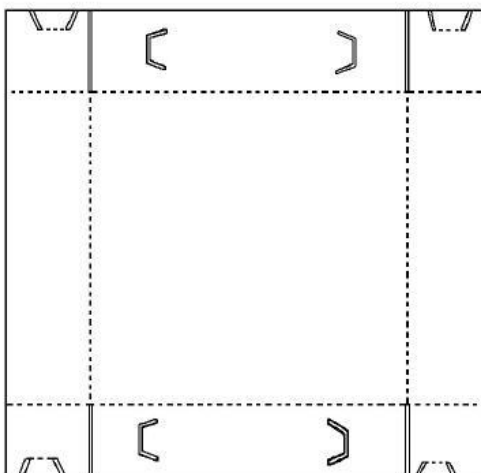

B65D 5/308

{the slot being provided in a lateral extension of a side wall combined with a tongue being a part of an adjacent side wall}

Definition statement

This place covers:

Illustrative example of subject matter classified in this group:

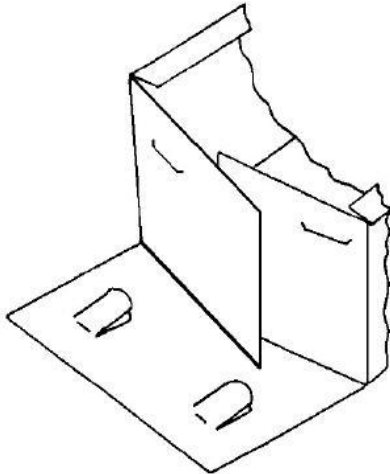
**B65D 5/32**

having bodies formed by folding and interconnecting two or more blanks {each blank forming a body part, whereby each body part comprises at least one outside face of the box, carton or tray}

References**Informative references**

Attention is drawn to the following places, which may be of interest for search:

With end closures formed by separately from tubular body	B65D 5/12
--	---------------------------

B65D 5/321

{at least one container body part formed by folding up portions of a single blank connected to a central panel from all sides}

Definition statement

This place covers:

Illustrative example of subject matter classified in this group:

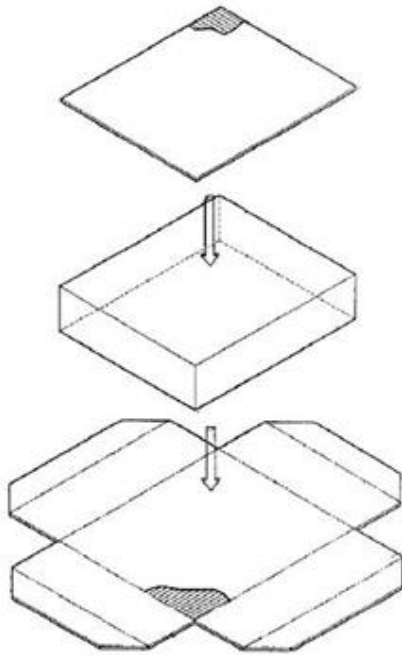

B65D 5/323

{and two further opposed body panels formed from two essentially planar blanks}

Definition statement

This place covers:

Illustrative example of subject matter classified in this group:

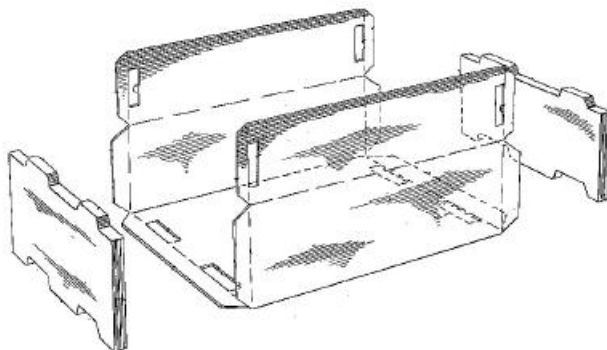

B65D 5/324

{at least two container body parts, each formed by folding a single blank to essentially U-shape}

Definition statement

This place covers:

Illustrative example of subject matter classified in this group:

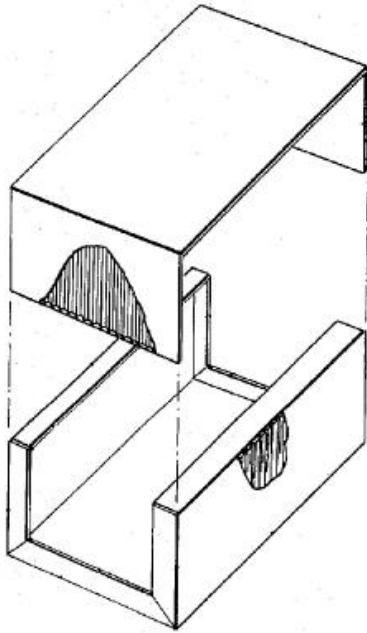

B65D 5/325

{whereby one blank forms three sides of the body, and the other blank forms the remaining sides, a hinged lid, and the opposite end closure}

Definition statement

This place covers:

Illustrative example of subject matter classified in this group:

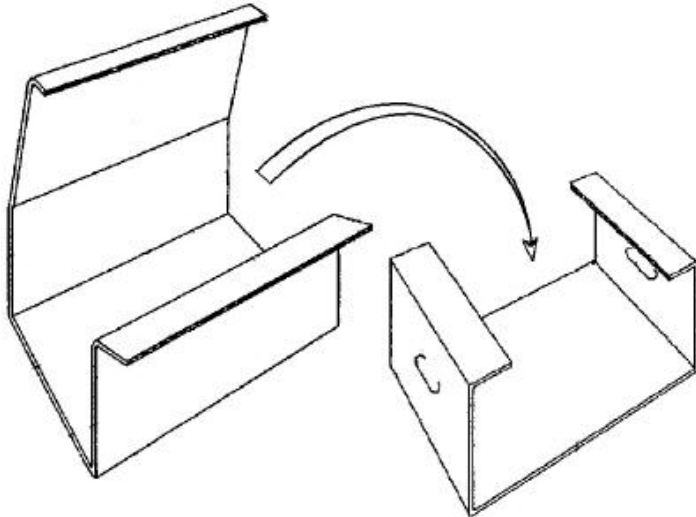
**B65D 5/327**

{at least two container body parts, each formed by folding a single blank to a permanently assembled tube}

Definition statement

This place covers:

Illustrative example of subject matter classified in this group:

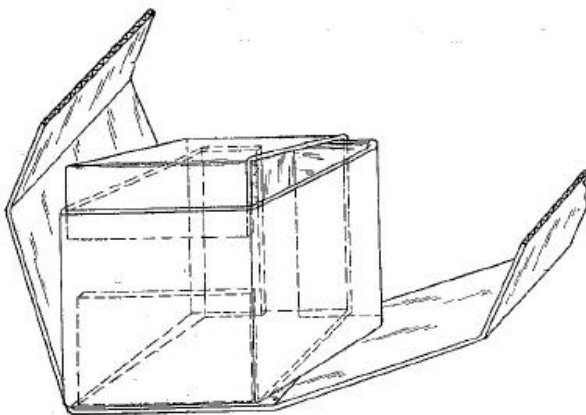

B65D 5/328

{and the tubular body parts being aligned axially to form a container}

Definition statement

This place covers:

Illustrative example of subject matter classified in this group:

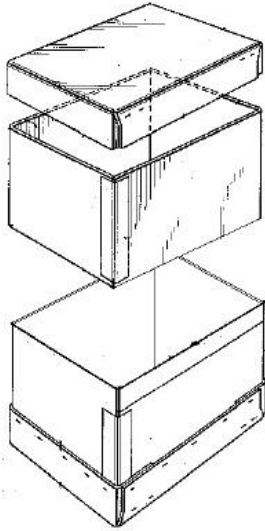
**B65D 5/36**

especially constructed to allow collapsing and re-erecting without disengagement of side or bottom connections

References**Limiting references**

This place does not cover:

Of variable capacity	B65D 5/0005
Devices formed separately from container body for holding in erected state	B65D 5/4283

B65D 5/3621

{collapsed along two fold lines of the tubular body}

Definition statement

This place covers:

Illustrative example of subject matter classified in this group:

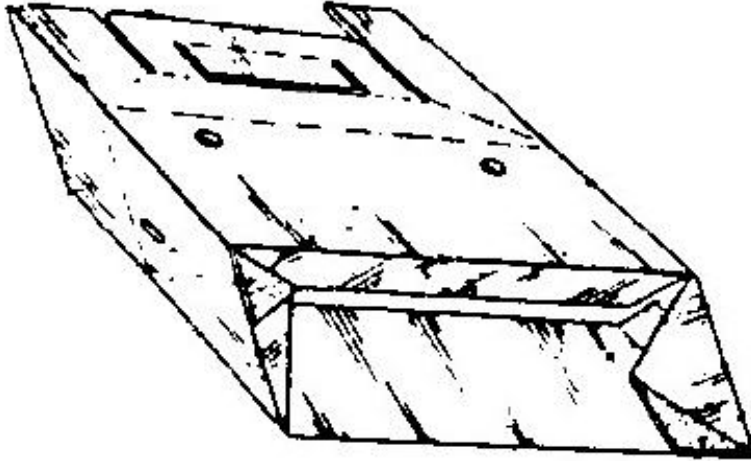

B65D 5/3628

{collapsed along median lines of two opposite sides of the rectangular tubular body}

Definition statement

This place covers:

Illustrative example of subject matter classified in this group:

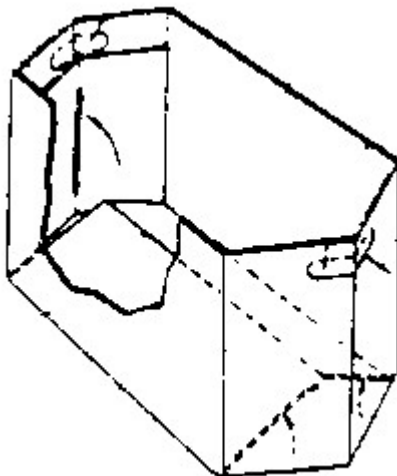

B65D 5/3642

{the secured corners presenting diagonal, bisecting or similar folding lines, the central panel presenting no folding line}

Definition statement

This place covers:

Illustrative example of subject matter classified in this group:

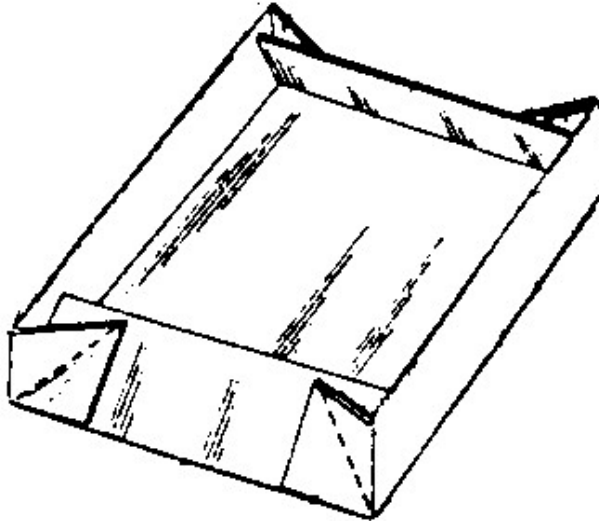
**B65D 5/365**

{the extensions of one or more sides being doubled-over to enclose extensions of adjacent sides}

References**Limiting references**

This place does not cover:

At least one side being extended and doubled-over to enclose the adjacent gusset flaps	B65D 5/3664
--	-----------------------------

Informative references

Attention is drawn to the following places, which may be of interest for search:

Held erect by extensions of one or more sides being doubled-over to enclose extensions of adjacent sides	B65D 5/22
--	---------------------------

B65D 5/3657

{the adjacent sides being interconnected by gusset folds}

References**Informative references**

Attention is drawn to the following places, which may be of interest for search:

With adjacent sides interconnected by gusset folds	B65D 5/24
--	---------------------------

B65D 5/3671

{the sides being connected to extensions of other sides by tongue-and-slot connections}

References**Informative references**

Attention is drawn to the following places, which may be of interest for search:

With tongue-and-slot or like connections between sides and extensions of other sides	B65D 5/30
--	---------------------------

B65D 5/3678

{collapsed along median lines of two opposite sides and the central panel}

Definition statement

This place covers:

Illustrative example of subject matter classified in this group:

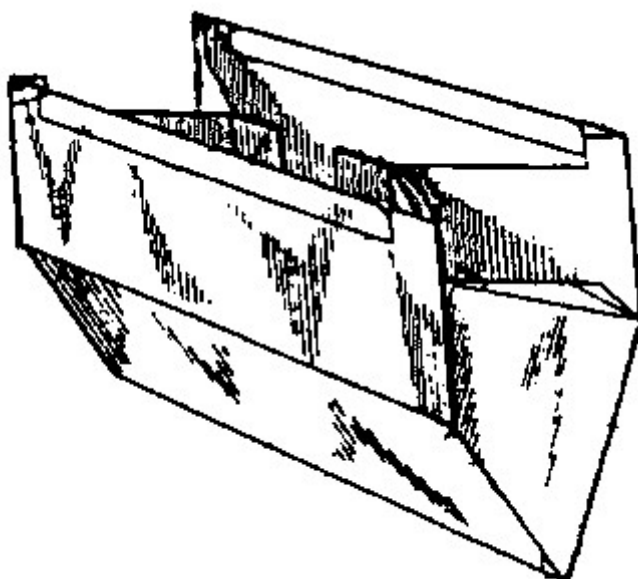

B65D 5/38**Drawer-and-shell type containers****References****Limiting references***This place does not cover:*

Dispensing means	B65D 5/728
------------------	----------------------------

B65D 5/42**Details of containers or of foldable or erectable container blanks****References****Limiting references***This place does not cover:*

Grouping of articles	B65D 69/00 , B65D 71/00
Packages for bulky articles such as fridges	B65D 85/64 , B65D 85/68

Informative references*Attention is drawn to the following places, which may be of interest for search:*

Details of packages formed by enclosing articles or materials in preformed containers	B65D 77/22
---	----------------------------

B65D 5/4204**{Inspection openings or windows}****Definition statement***This place covers:*

Illustrative example of subject matter classified in this group:

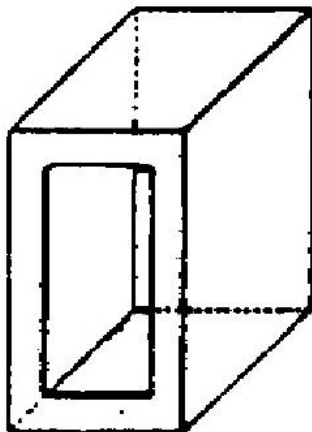

B65D 5/4208

{Means facilitating suspending, lifting, handling, or the like of containers (handles [B65D 5/46](#))}

Definition statement

This place covers:

Illustrative example of subject matter classified in this group:

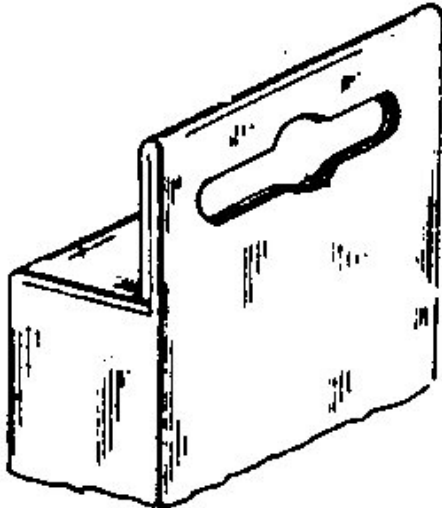
**References****Informative references**

Attention is drawn to the following places, which may be of interest for search:

External fittings for facilitating lifting or suspending of containers	B65D 25/22
--	----------------------------

B65D 5/4212

{Information or decoration elements, e.g. content indicators, or for mailing ([B65D 5/522](#) takes precedence)}

References**Limiting references**

This place does not cover:

Containers provided with decoration or information elements which are displaced to display the contents	B65D 5/522
Decorative ribbons and rosettes	B65D 67/00

Informative references

Attention is drawn to the following places, which may be of interest for search:

Means of attachment of smaller articles of tags	B65D 23/14
Means for the attachment of labels, cards, coupons or the like	B65D 25/205

Information or decoration elements	B65D 33/004
The inserts or accessories being located within a pouch or envelope attached to the exterior of the packages	B65D 75/545

B65D 5/4216

{Cards, coupons or the like formed integrally with, or printed directly on, the container or lid}

Definition statement

This place covers:

Illustrative example of subject matter classified in this group:

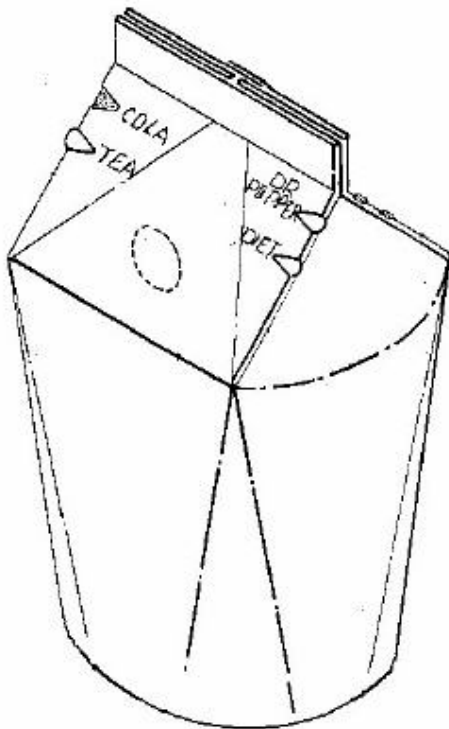

B65D 5/422

{as an extra panel or panels folded against or inside the container ([B65D 5/4237](#) takes precedence)}

Definition statement

This place covers:

Illustrative example of subject matter classified in this group:

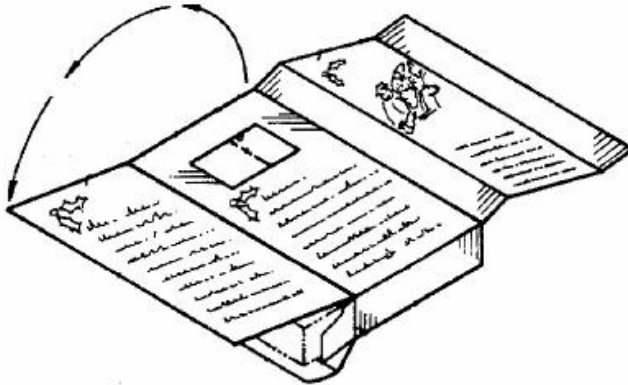
**References****Limiting references**

This place does not cover:

Located in a compartment formed by a container wall and additional panel or panels formed integrally with the container	B65D 5/4237
Pull- or fold out labels	G09F 3/0289

B65D 5/4225

{as an extra panel or panels projecting out of the plane of the container ([B65D 5/4241](#) takes precedence)}

Definition statement

This place covers:

Illustrative example of subject matter classified in this group:

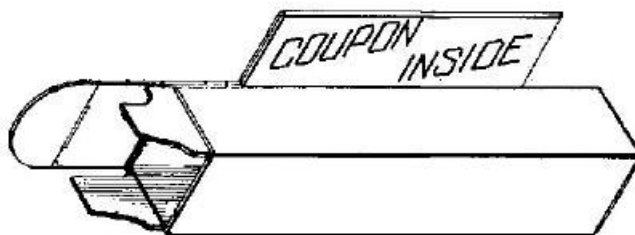

References

Limiting references

This place does not cover:

Located in a compartment formed by a double-walled panel projecting out of the plane of the container	B65D 5/4241
---	-----------------------------

B65D 5/4229

{in the form of a detachable panel}

Definition statement

This place covers:

Illustrative example of subject matter classified in this group:

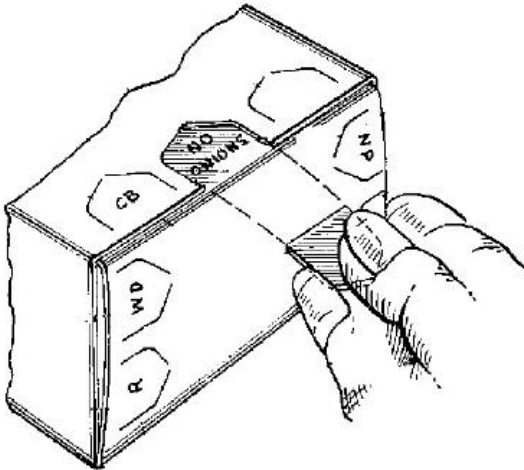

B65D 5/4237

{located in a compartment formed by a container wall and additional panel or panels formed integrally with the container}

Definition statement

This place covers:

Illustrative example of subject matter classified in this group:

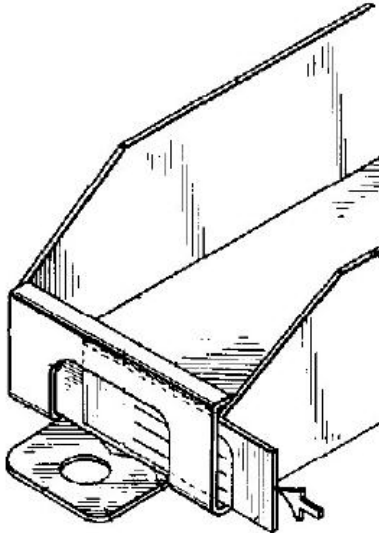

B65D 5/4245

{Bands covering at least 3 adjacent faces of a container ([B65D 5/4262](#) takes precedence)}

Definition statement

This place covers:

Illustrative example of subject matter classified in this group:

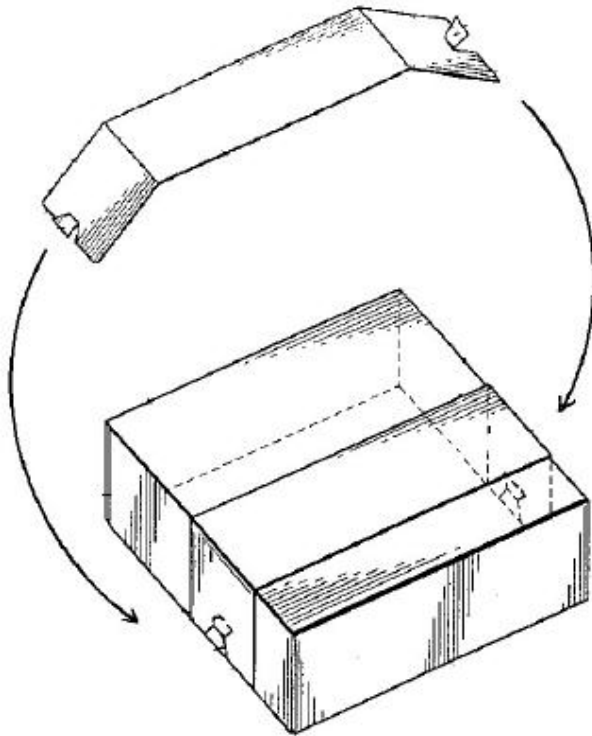
**References****Limiting references**

This place does not cover:

Bands covering at least 3 adjacent faces of a container provided with a decoration	B65D 5/4262
--	-----------------------------

B65D 5/425

{Decoration elements}

Definition statement

This place covers:

Integral to attached elements other than the package contents added to the package for decorative purposes

Illustrative example of subject matter classified in this group:



B65D 5/4254

{formed by two or mating closure panels, e.g. forming a butterfly, bow-tie, etc.}

Definition statement

This place covers:

Illustrative example of subject matter classified in this group:

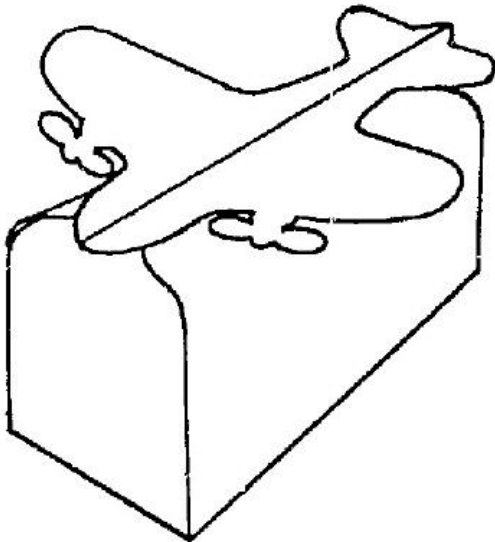

B65D 5/4258

{providing 3-dimensional perspective images by means of two or more spaced apart images}

Definition statement

This place covers:

Illustrative example of subject matter classified in this group:

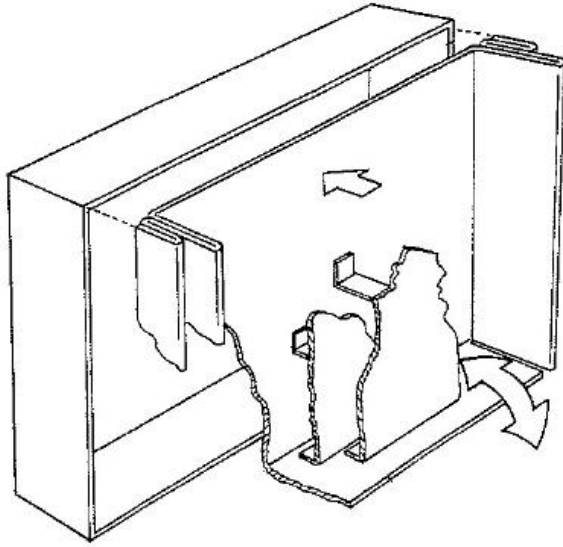

B65D 5/4262

{Bands covering at least 3 adjacent faces of a container provided with a decoration, e.g. bow}

Definition statement

This place covers:

Illustrative example of subject matter classified in this group:

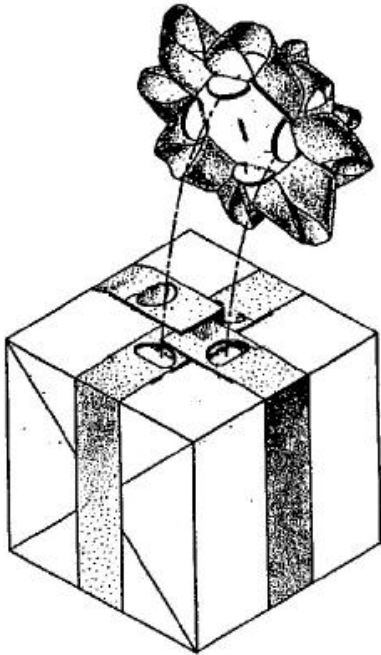
**B65D 5/4266**

{Folding lines, score lines, crease lines}

Definition statement

This place covers:

folding, score or crease lines of particular shape, e.g. undulating, interrupted, etc., or made in a particular way, e.g. broader than usual, of varying depth, etc.

Illustrative example of subject matter classified in this group:

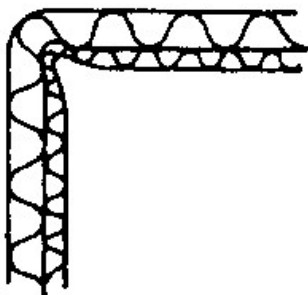

References

Limiting references

This place does not cover:

Tear strips or score lines for opening or dividing into separate parts	B65D 5/54
--	---------------------------

B65D 5/427

{Individual packages joined together, e.g. by means of integral tabs
([B65D 5/5495](#) takes precedence)}

Definition statement

This place covers:

Illustrative example of subject matter classified in this group:

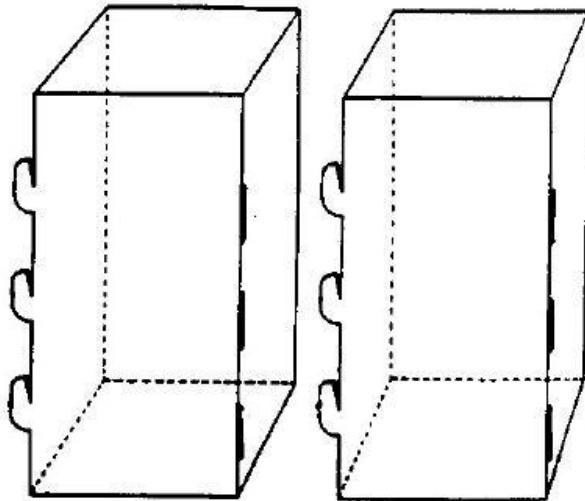

B65D 5/4275

{by bonding, adhesive, hook and loop-type fastener or the like}

Definition statement

This place covers:

Illustrative example of subject matter classified in this group (glue or hook-and-loop fastener):

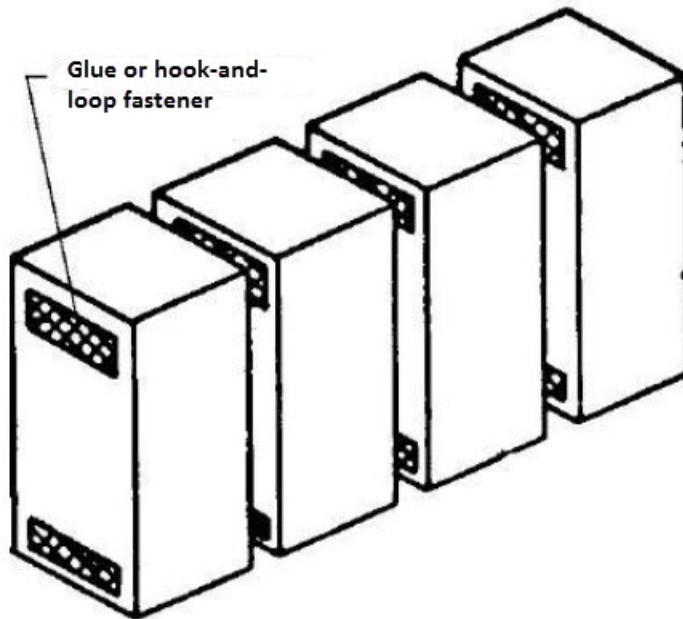
**Relationships with other classification places**

For hook-and-loop fasteners add [B65D 2313/02](#).

B65D 5/4279

{Joints, seams, leakproof joints or corners, special connections between panels ([B65D 5/209](#) takes precedence)}

Definition statement

This place covers:

Illustrative example of subject matter classified in this group:



References

Limiting references

This place does not cover:

The adjacent edges of folded-up portions being joined by moulding seams in situ	B65D 5/209
---	----------------------------

Informative references

Attention is drawn to the following places, which may be of interest for search:

With tongue-and-slow or like connections between sides and extensions of other sides	B65D 5/30
--	---------------------------

B65D 5/4283

{Connections formed by separate elements, e.g. clips, bands, straps
([B65D 5/0227](#), [B65D 5/0236](#) take precedence)}

Definition statement

This place covers:

Illustrative example of subject matter classified in this group:

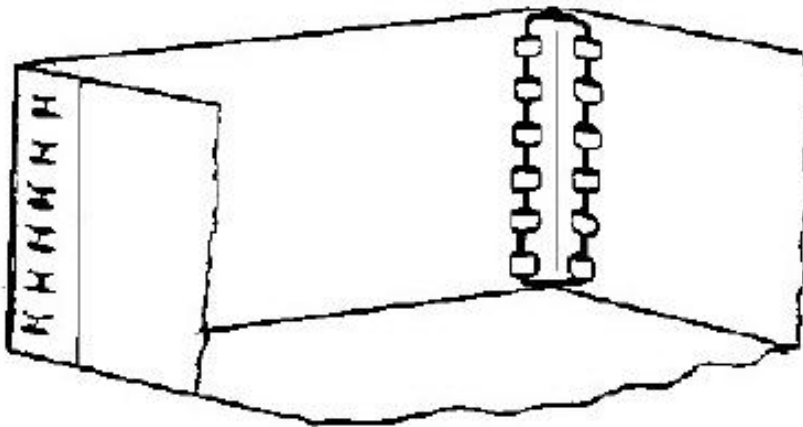

References

Limiting references

This place does not cover:

With end closures formed by inward folding of flaps and securing them by heat-sealing, adhesive applied to the flaps or staples	B65D 5/0227
With end closures formed by inward folding of flaps and securing them by adhesive tapes, labels or the like; for decoration purposes	B65D 5/0236
Releasable fastenings clips	F16B 2/20

B65D 5/4287

{the container being formed by folding-up portions connected to a central panel from all sides, adjacent sides being interconnected by gusset folds and the container being maintained in erected condition by means of the separate connectors coacting with the gusset folds}

Definition statement

This place covers:

Illustrative example of subject matter classified in this group:

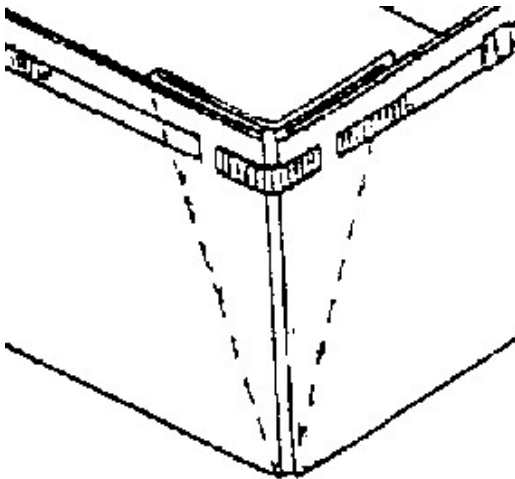
**References****Informative references**

Attention is drawn to the following places, which may be of interest for search:

Tray construction per se	B65D 5/24
--------------------------	---------------------------

B65D 5/4291

{Containers provided with an acoustic device, e.g. for indicating opening of the package}

References**Informative references**

Attention is drawn to the following places, which may be of interest for search:

The closure being provided with transient audible or visual signaling means	B65D 51/248
Initial opening or unauthorised access being indicated by the presence or absence of an audible or electrical signal	B65D 55/028

B65D 5/4295**{Ventilating arrangements, e.g. openings, space elements}****Definition statement***This place covers:*

Illustrative example of subject matter classified in this group:

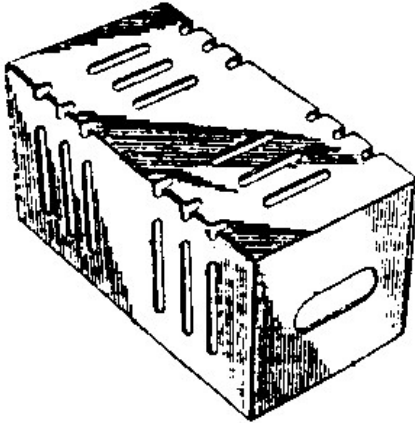
**References****Informative references***Attention is drawn to the following places, which may be of interest for search:*

Venting means	B65D 2205/00
For the circulation of warm air to improve the heating of packaged food	B65D 2581/3455

B65D 5/443**{Integral reinforcements, e.g. folds, flaps (double walls [B65D 5/02](#))}****Definition statement***This place covers:*

Illustrative example of subject matter classified in this group:

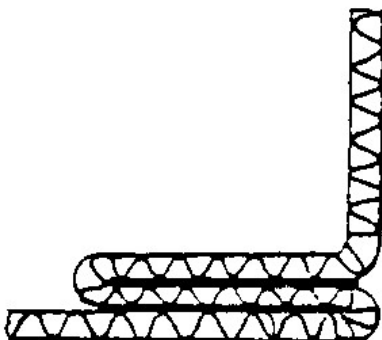

References

Limiting references

This place does not cover:

Double walls for tubular containers	B65D 5/0281
-------------------------------------	-----------------------------

B65D 5/446

{Wooden reinforcements}

Definition statement

This place covers:

Illustrative example of subject matter classified in this group:

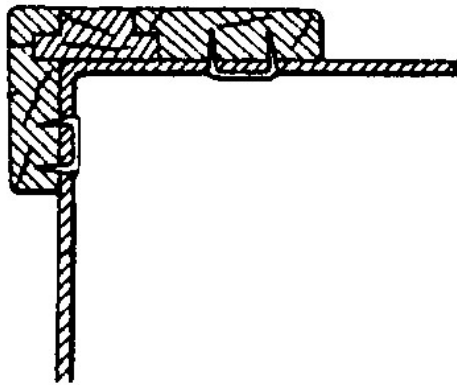

B65D 5/448

{Metal or wire reinforcements}

Definition statement

This place covers:

Illustrative example of subject matter classified in this group:

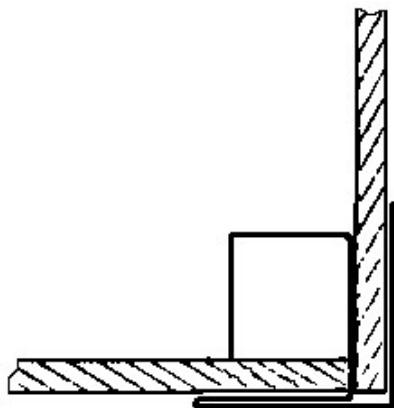

B65D 5/46

Handles

References

Limiting references

This place does not cover:

Means for suspending containers	B65D 5/4208
---------------------------------	-----------------------------

B65D 5/46016

{Straps used as handles fixed to the container by glueing, stapling, heat-sealing (for packages in wrappers [B65D 75/56](#))}

Definition statement

This place covers:

Illustrative example of subject matter classified in this group:

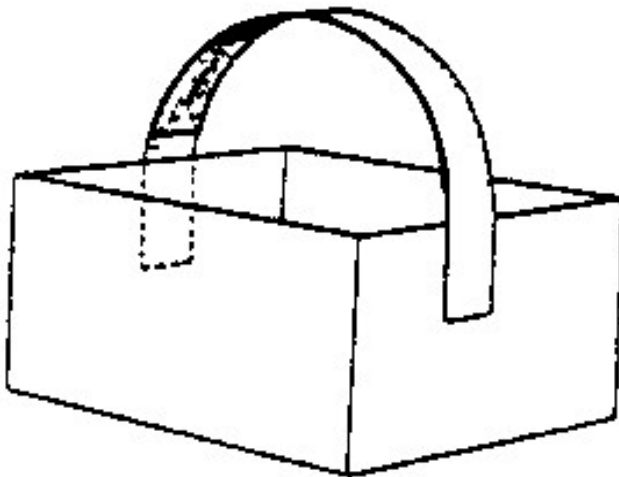

B65D 5/46024

{Straps used as handles with anchoring elements fixed in slots}

Definition statement

This place covers:

Illustrative example of subject matter classified in this group:

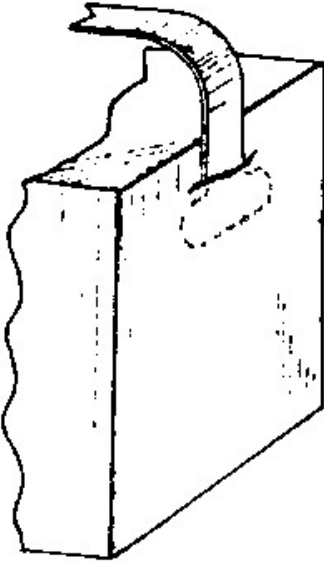

B65D 5/46032

{Handles with anchoring elements, e.g. formed by folding a blank (B65D 5/46064 takes precedence; straps B65D 5/46024)}

Definition statement

This place covers:

Illustrative example of subject matter classified in this group:

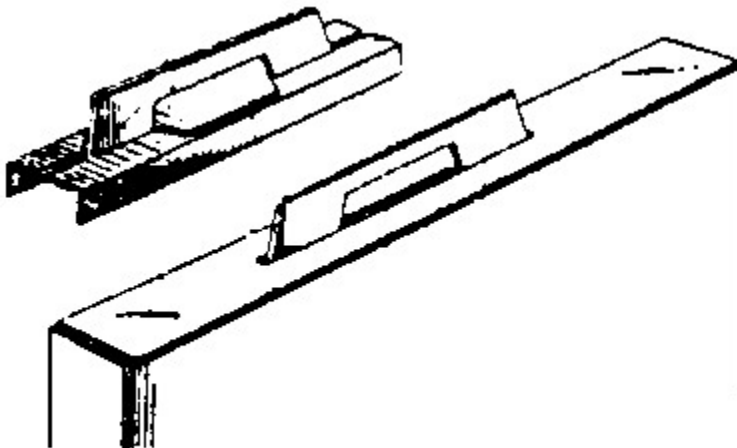

References

Limiting references

This place does not cover:

Formed by folding a blank serving also as a partition in the container	B65D 5/46064
--	------------------------------

B65D 5/4604

{not formed by folding a blank}

Definition statement

This place covers:

Illustrative example of subject matter classified in this group:

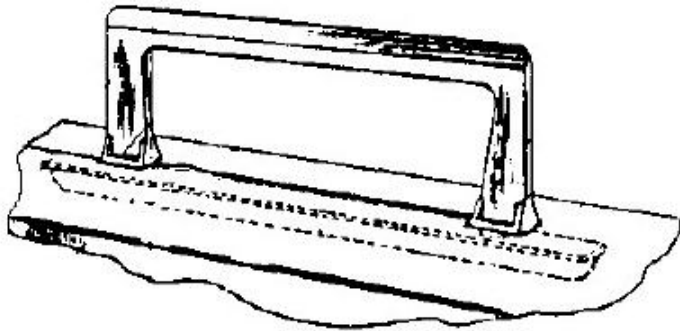

References

Informative references

Attention is drawn to the following places, which may be of interest for search:

Handles for carrying purposes	A45F 5/10
-------------------------------	---------------------------

B65D 5/46048**{made of metal wire}****Definition statement***This place covers:*

Illustrative example of subject matter classified in this group:

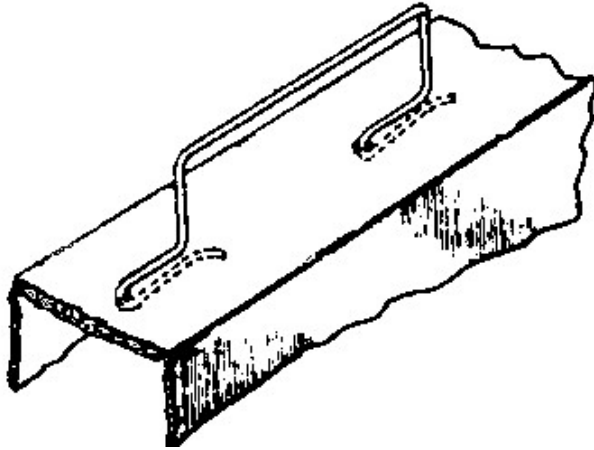
**References*****Informative references****Attention is drawn to the following places, which may be of interest for search:*

Handles for carrying purposes	A45F 5/10
-------------------------------	---------------------------

B65D 5/46056**{made of cord}****Definition statement***This place covers:*

Illustrative example of subject matter classified in this group:

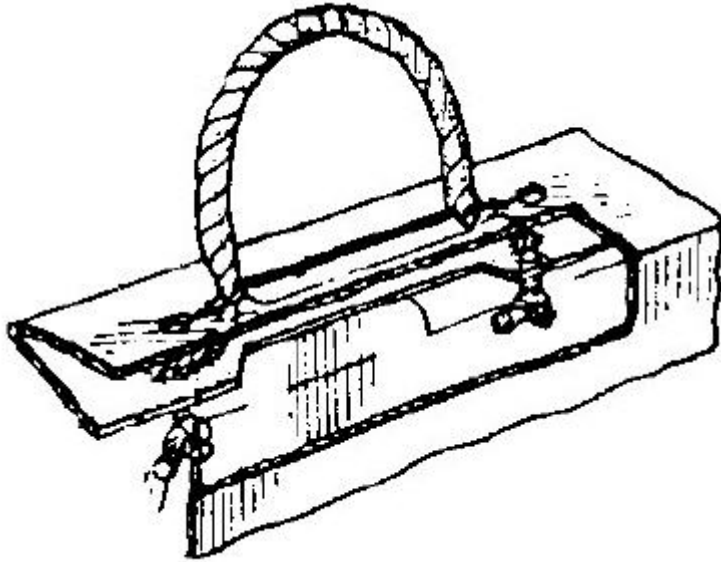
**References****Informative references***Attention is drawn to the following places, which may be of interest for search:*

Handles for carrying purposes	A45F 5/10
-------------------------------	---------------------------

B65D 5/46064

{formed by folding a blank serving also as a partition in the container}

Definition statement

This place covers:

Illustrative example of subject matter classified in this group:

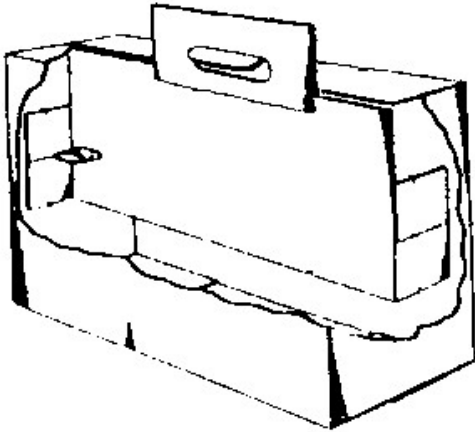

B65D 5/4608

{Handgrip holes}

Definition statement

This place covers:

Illustrative example of subject matter classified in this group:

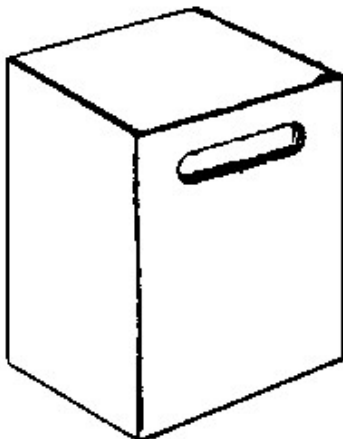

B65D 5/46096

{two opposite closure flaps being provided with handle elements which are in contact with each other}

Definition statement

This place covers:

Illustrative example of subject matter classified in this group:

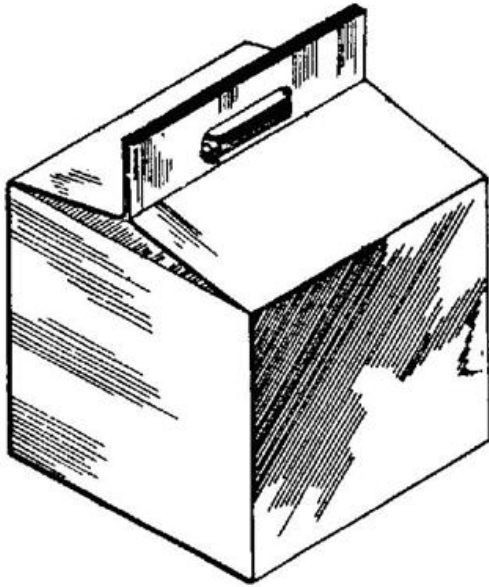

References

Limiting references

This place does not cover:

If extensions of side flaps	B65D 5/46088
-----------------------------	------------------------------

B65D 5/46104

{at least one of the other closure flaps being provided with a slit which completely encompasses the two handle elements to maintain the handle in position}

Definition statement

This place covers:

Illustrative example of subject matter classified in this group:

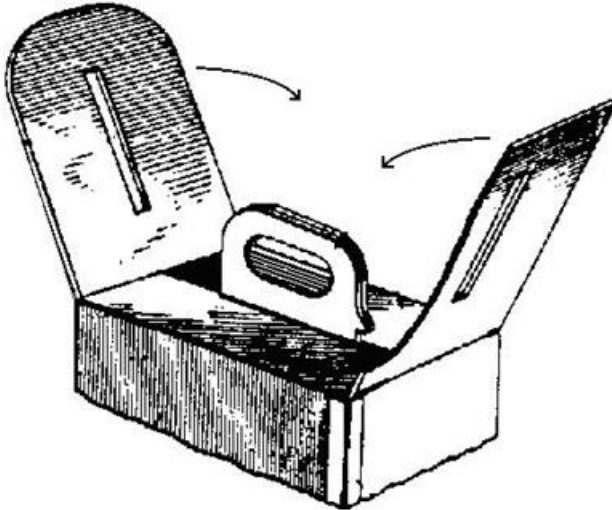

B65D 5/46112

{either the handle elements being formed with lugs which engage with the other side walls or closure flaps, or the other closure flaps folding over a part of the handle to maintain the handle in position}

Definition statement

This place covers:

Illustrative example of subject matter classified in this group:

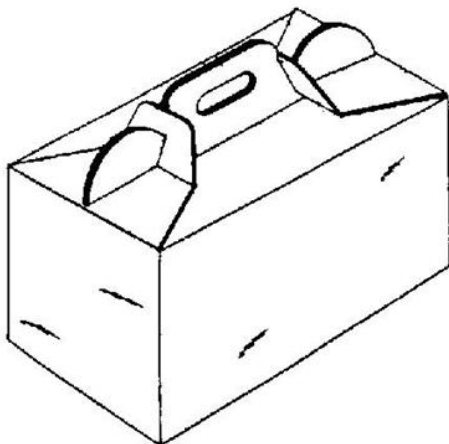

B65D 5/4612

{formed by extensions of side flaps or by side flaps of a container formed by folding-up portions connected to a central panel from all sides}

Definition statement

This place covers:

Illustrative example of subject matter classified in this group:

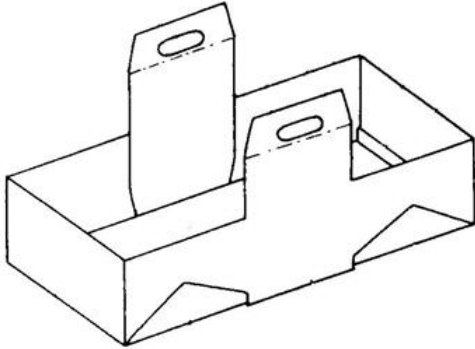

B65D 5/46136

{at least one of the other closure flaps being provided with a slit which completely encompasses the two handle elements to maintain the handle in position}

Definition statement

This place covers:

Illustrative example of subject matter classified in this group:

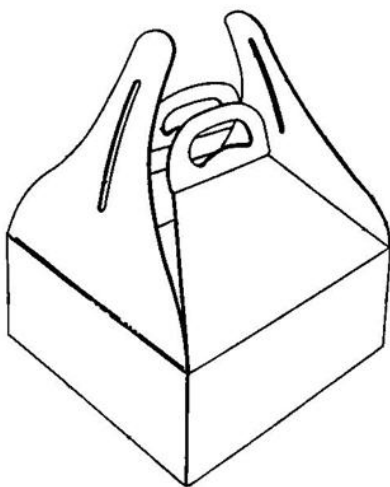

B65D 5/46144

{either the handle elements being formed with lugs which engage with the other side walls or closure flaps, or the other closure flaps folding over a part of the handle to maintain the handle in position}

Definition statement

This place covers:

Illustrative example of subject matter classified in this group:

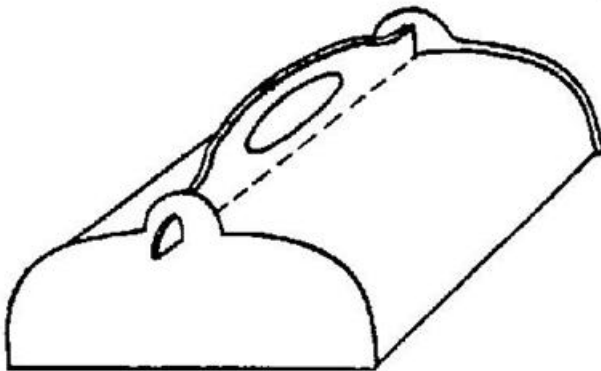
**B65D 5/46152**

{formed in closure flaps of a container formed by folding a blank to U-shape to form the base and opposite sides, the remaining sides being formed by extensions of these opposite sides}

Definition statement

This place covers:

Illustrative example of subject matter classified in this group:

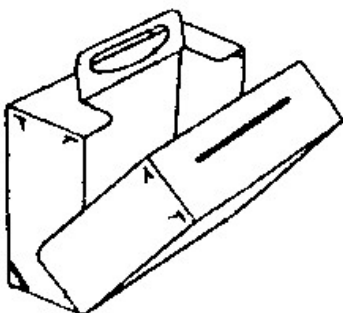

B65D 5/46168

{at least one of the other closure flaps being provided with a slit which completely encompasses the two handle elements to maintain the handle in position}

Definition statement

This place covers:

Illustrative example of subject matter classified in this group:

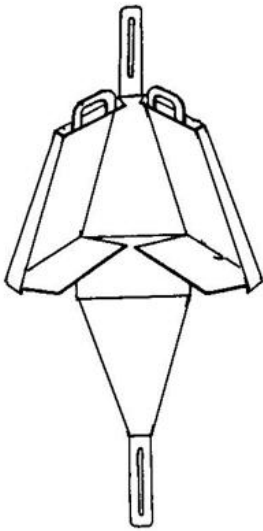

B65D 5/46176

{either the handle elements being formed with lugs which engage with the other side walls or closure flaps, or the other closure flaps folding over a part of the handle to maintain the handle in position}

Definition statement

This place covers:

Illustrative example of subject matter classified in this group:

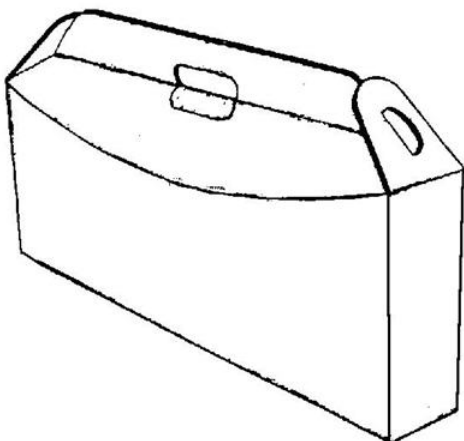

B65D 5/46184

{formed by extensions of parts of the blank, serving also as a partition in the container}

Definition statement

This place covers:

Illustrative example of subject matter classified in this group:

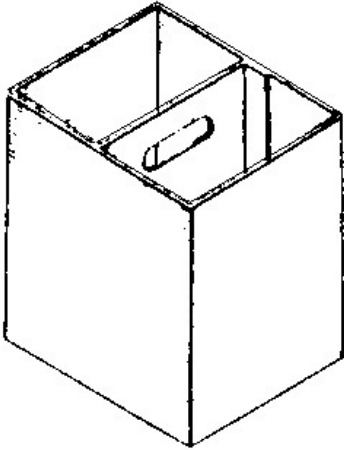

B65D 5/46192

{formed by incisions in the container or blank forming straps used as handles}

Definition statement

This place covers:

Illustrative example of subject matter classified in this group:

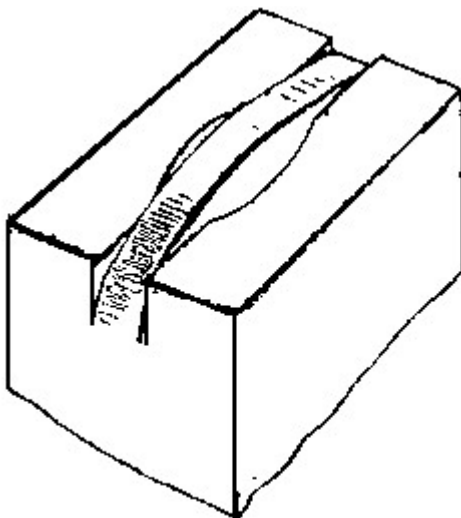

B65D 5/48**Partitions****References****Informative references**

Attention is drawn to the following places, which may be of interest for search:

For separating interconnected containers	B65D 5/5495
--	-----------------------------

B65D 5/48002**{integral}****References****Informative references**

Attention is drawn to the following places, which may be of interest for search:

Formed by folding or erecting one blank, and provided with vertical partitions	B65D 71/0022
Partitions extending from the upper or lower wall	B65D 2571/00339
Partitions extending from at least a side wall	B65D 2571/0037

B65D 5/48004**{Squaring, i.e. at least four not aligned compartments}****References****Informative references**

Attention is drawn to the following places, which may be of interest for search:

Formed by folding or erecting one blank, and provided with vertical partitions	B65D 71/0022
Containers with compartments formed by erecting one blank	B65D 85/325
Partitions extending from the upper or lower wall, squarings or the like	B65D 2571/00345
Partitions extending from at least a side wall, squarings or the like	B65D 2571/00376

B65D 5/48006

{Longitudinal partition provided with cut flaps folded perpendicular to the partition}

Definition statement

This place covers:

Illustrative example of subject matter classified in this group:

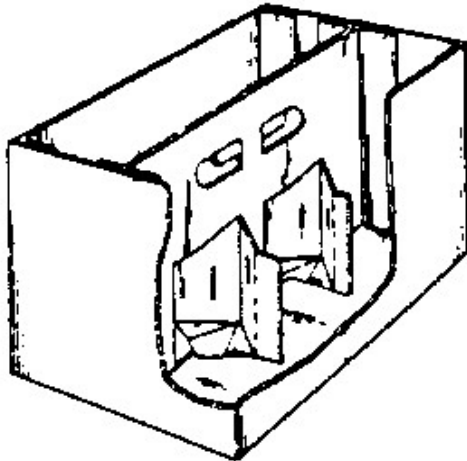

B65D 5/48008

{formed by folding extensions hinged to the upper or lower edges of a tubular body ([B65D 5/48006](#) takes precedence)}

Definition statement

This place covers:

Illustrative example of subject matter classified in this group:

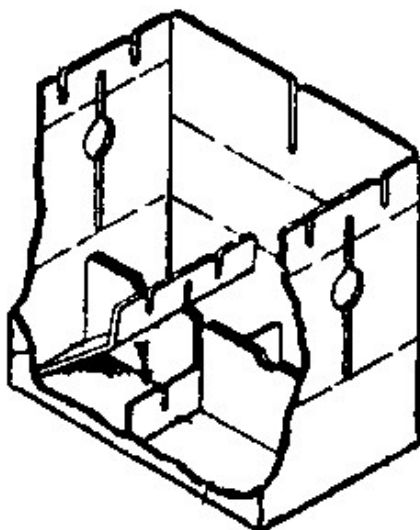

References

Limiting references

This place does not cover:

Longitudinal partition provided with cut flaps folded perpendicular to the partition	B65D 5/48006
--	------------------------------

B65D 5/4801

{formed by folding extensions of side panels of a "cross-like" body blank}

Definition statement

This place covers:

Illustrative example of subject matter classified in this group:

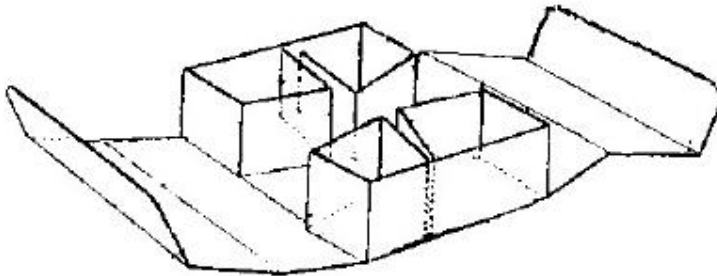

B65D 5/48012

{combined with inserted partitions}

Definition statement

This place covers:

Illustrative example of subject matter classified in this group:

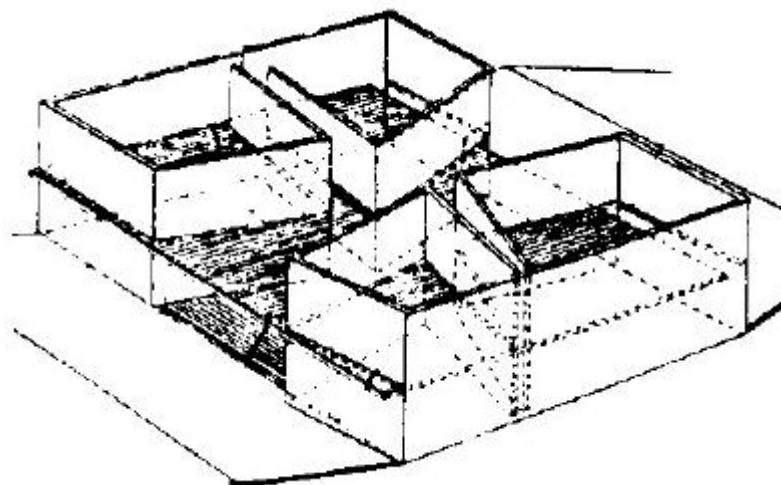

B65D 5/48014

{formed by folding extensions hinged to the side edges of a tubular body ([B65D 5/48004](#) takes precedence; partition separated by erecting the body [B65D 5/48048](#))}

Definition statement

This place covers:

Illustrative example of subject matter classified in this group:

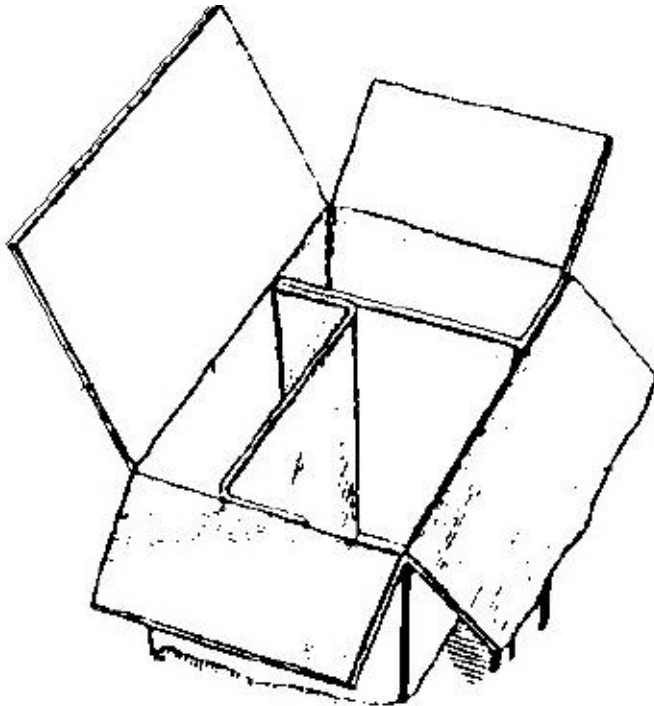
**References****Limiting references**

This place does not cover:

Squaring	B65D 5/48004
----------	------------------------------

Informative references

Attention is drawn to the following places, which may be of interest for search:

Formed by folding inwardly of extensions hinged to the side edges of the body	B65D 5/5016
---	-----------------------------

B65D 5/48016

{formed by folding extensions hinged to the upper or lower edges of a tubular body ([B65D 5/48008](#) takes precedence)}

Definition statement

This place covers:

Illustrative example of subject matter classified in this group:

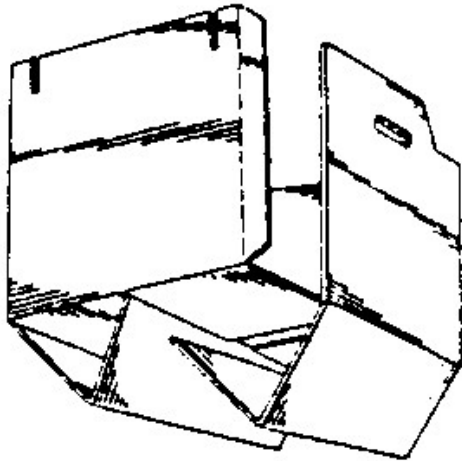
**References****Limiting references**

This place does not cover:

Formed by folding extensions hinged to the upper or lower edges of a tubular body	B65D 5/48008
---	------------------------------

B65D 5/48018

{formed by folding extensions of side panels of a "cross-like" body blank
([B65D 5/4801](#) takes precedence)}

Definition statement

This place covers:

Illustrative example of subject matter classified in this group:

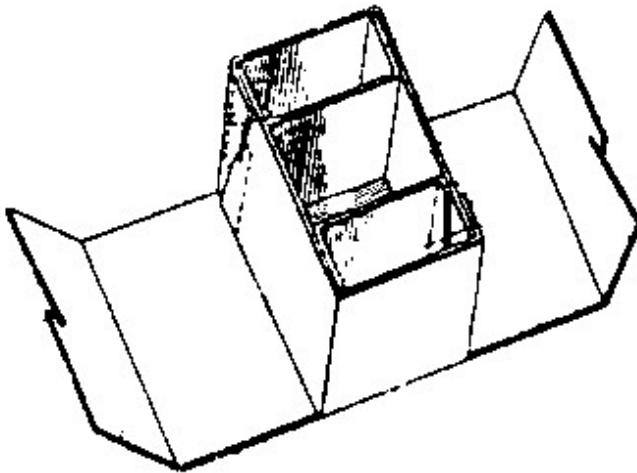
**References****Limiting references**

This place does not cover:

Squaring formed by folding extensions of side panels of a "cross-like" body blank	B65D 5/4801
---	-----------------------------

B65D 5/4802

{formed by folding inwardly portions cut in the body ([B65D 5/48006](#) takes precedence)}

Definition statement

This place covers:

Illustrative example of subject matter classified in this group:

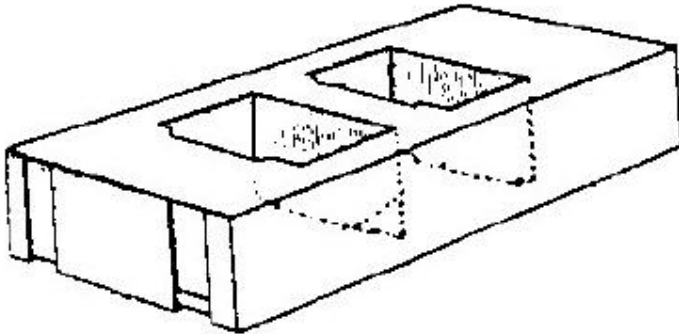
**References****Limiting references**

This place does not cover:

Longitudinal partition provided with cut flaps folded perpendicular to the partition	B65D 5/48006
--	------------------------------

Informative references

Attention is drawn to the following places, which may be of interest for search:

Formed by folding or erecting one blank, and provided with vertical partitions	B65D 71/0022
Partitions extending from the upper or lower wall	B65D 2571/00339
Partitions extending from at least a side wall	B65D 2571/0037

B65D 5/48022

{formed by two parallel panels located in the base of a tray being folded up towards each other}

Definition statement

This place covers:

Illustrative example of subject matter classified in this group:

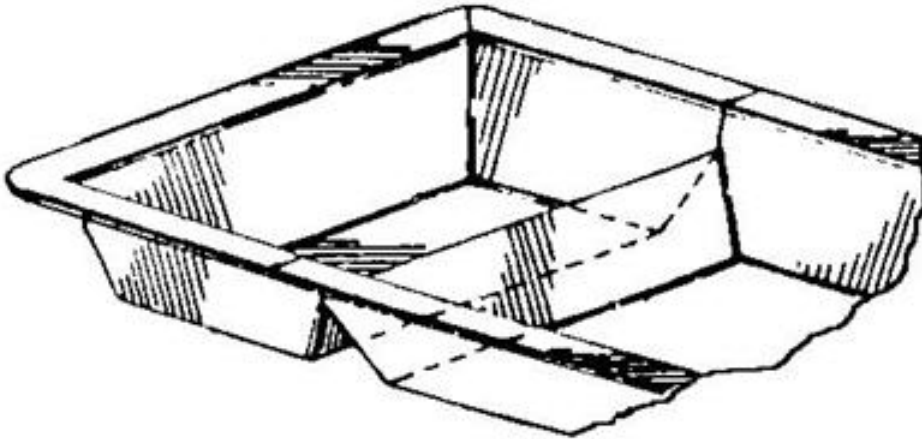
**References****Informative references**

Attention is drawn to the following places, which may be of interest for search:

Strip provided with series of folding lines forming the partitions	B65D 5/48042
--	------------------------------

B65D 5/48026

{Squaring or like elements, e.g. honeycomb element, i.e. at least four not aligned compartments ([B65D 5/48012](#) takes precedence)}

References**Limiting references**

This place does not cover:

Combined with inserted partitions	B65D 5/48012
-----------------------------------	------------------------------

Informative references

Attention is drawn to the following places, which may be of interest for search:

Containers with compartments formed by folding and inter-connecting of two or more blanks	B65D 85/327
---	-----------------------------

B65D 5/48028

{formed by folding a single blank ([B65D 5/48034](#) takes precedence)}

Definition statement

This place covers:

Illustrative example of subject matter classified in this group:

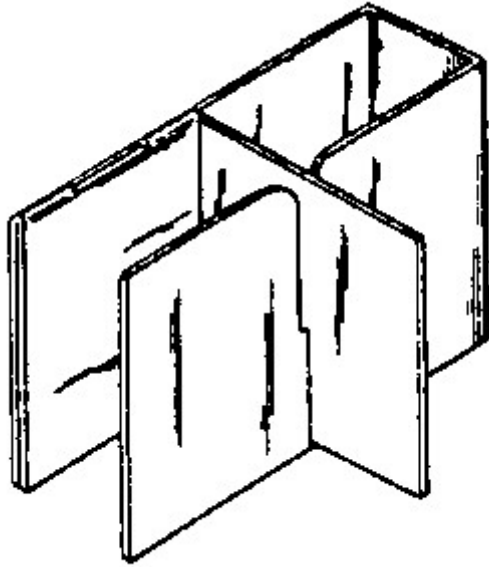
**References****Limiting references**

This place does not cover:

By folding a single blank	B65D 5/48034
Longitudinal partition provided with cut flaps folded perpendicular to the partition	B65D 5/48036

B65D 5/4803

{not made of paper, e.g. of moulded plastic}

Definition statement

This place covers:

Illustrative example of subject matter classified in this group:

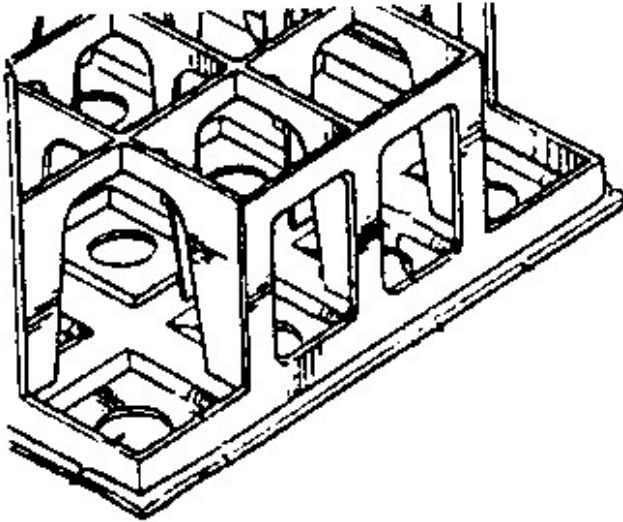

B65D 5/48032

{made of paper, provided with an at least partial bottom}

Definition statement

This place covers:

Illustrative example of subject matter classified in this group:

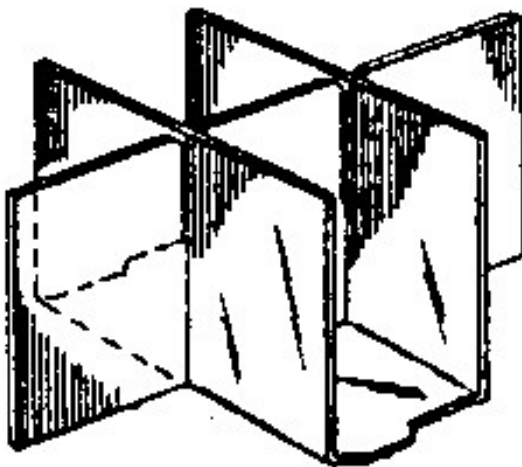

B65D 5/48034

{by folding a single blank}

Definition statement

This place covers:

Illustrative example of subject matter classified in this group:

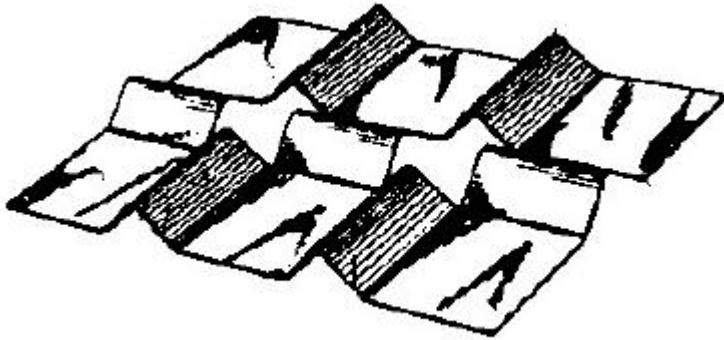

B65D 5/48036

{Longitudinal partition provided with cut flaps folded perpendicular to the partition}

Definition statement

This place covers:

Illustrative example of subject matter classified in this group:

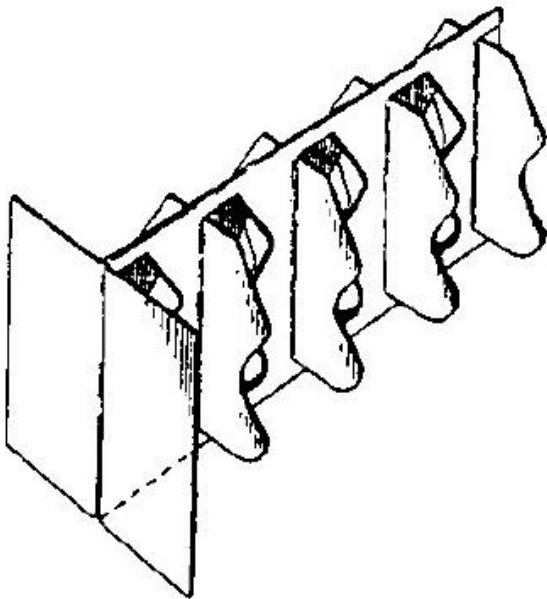

B65D 5/48038

{Strips crossing each other}

Definition statement

This place covers:

Illustrative example of subject matter classified in this group:

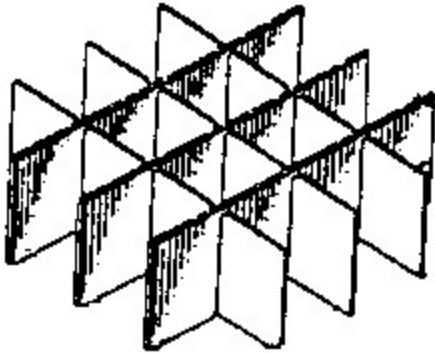

B65D 5/4804

{formed by folding strips essentially in tubes, U- or S-shape}

Definition statement

This place covers:

Illustrative example of subject matter classified in this group:

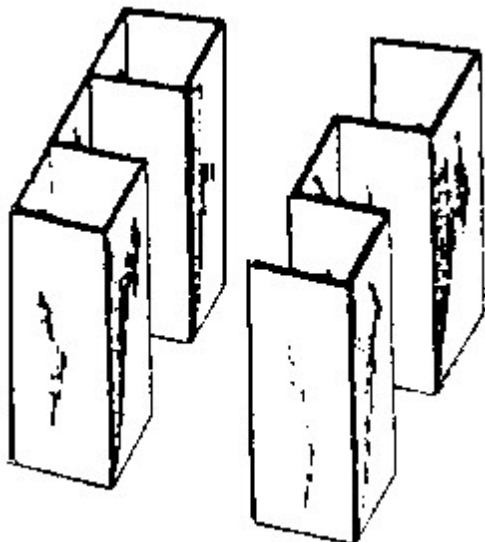

B65D 5/48042

{Strip provided with series of folding lines forming the partitions}

Definition statement

This place covers:

Illustrative example of subject matter classified in this group:

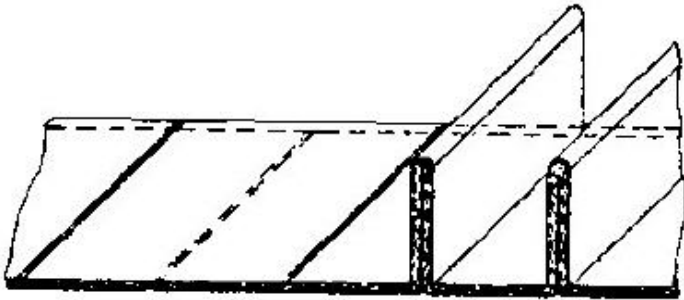
**References****Informative references**

Attention is drawn to the following places, which may be of interest for search:

Formed by two parallel panels located in the base of a tray being folded up towards each other	B65D 5/48022
--	------------------------------

B65D 5/48044

{Blank provided with cut flaps folded perpendicular to the blank ([B65D 5/48026](#) takes precedence)}

Definition statement

This place covers:

Illustrative example of subject matter classified in this group:

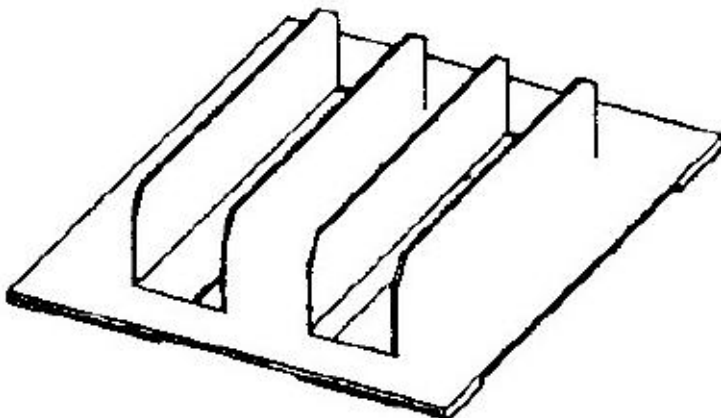

References

Limiting references

This place does not cover:

Squaring or like elements	B65D 5/48026
---------------------------	------------------------------

B65D 5/48046

{Plain strips not fixed by gluing or other fastening elements ([B65D 5/48048](#) takes precedence)}

Definition statement

This place covers:

Illustrative example of subject matter classified in this group:

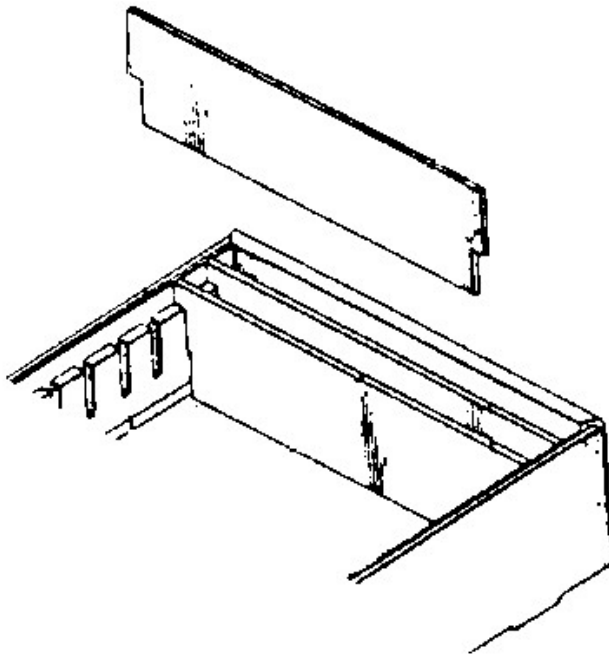

References

Limiting references

This place does not cover:

Single partition formed by folding one or more blanks and provided with flaps fixed to or maintained by parts of the container body	B65D 5/48048
---	------------------------------

B65D 5/48048

{Single partition formed by folding one or more blanks and provided with flaps fixed to or maintained by parts of the container body ([B65D 5/4804](#) takes precedence)}

Definition statement

This place covers:

Illustrative example of subject matter classified in this group:

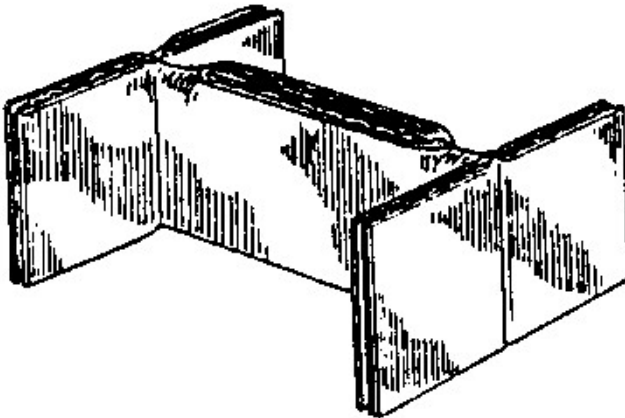

References

Limiting references

This place does not cover:

Formed by folding strips essentially in tubes	B65D 5/4804
---	-----------------------------

B65D 5/5004

{formed as an extension of the end closures (hollow or recessed end closures [B65D 5/0245](#))}

Definition statement

This place covers:

Illustrative example of subject matter classified in this group:

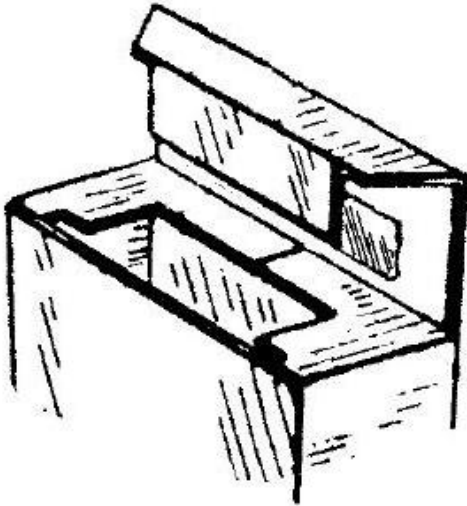

B65D 5/5007

{formed by inwardly protruding of folded parts of the body}

Definition statement

This place covers:

Illustrative example of subject matter classified in this group:

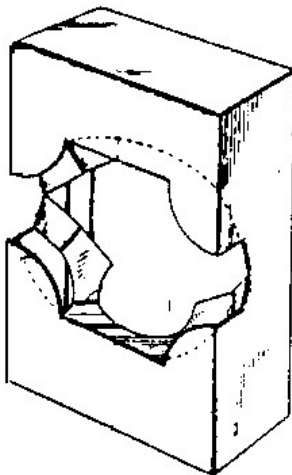

B65D 5/5009

{in combination with the end closures or extensions thereof}

Definition statement

This place covers:

Illustrative example of subject matter classified in this group:

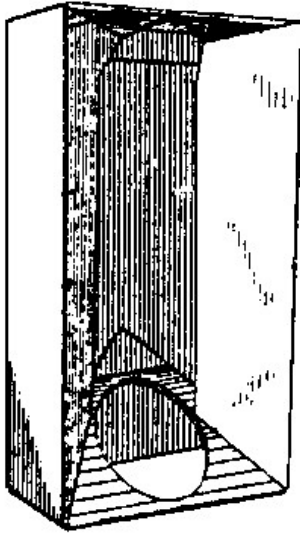

B65D 5/5011

{formed by folding inwardly of extensions hinged to the upper or lower edges of the body}

Definition statement

This place covers:

Illustrative example of subject matter classified in this group:

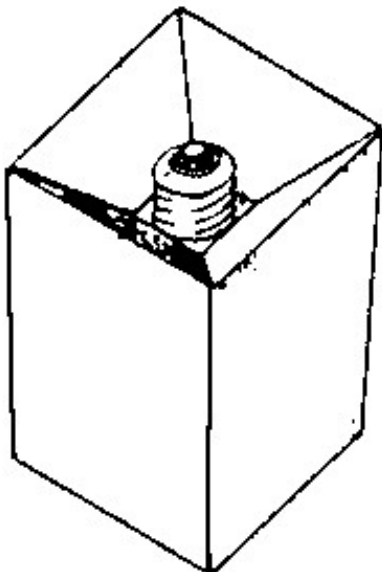

References

Limiting references

This place does not cover:

Formed as an extension of the end closures	B65D 5/5004
--	-----------------------------

Informative references

Attention is drawn to the following places, which may be of interest for search:

With end closures formed by inward-folding of self-locking flaps hinged to tubular body	B65D 5/10
Sleeves	B65D 59/04

B65D 5/5014

{and with an integral end closure ([B65D 5/5004](#) takes precedence)}

Definition statement

This place covers:

Illustrative example of subject matter classified in this group:

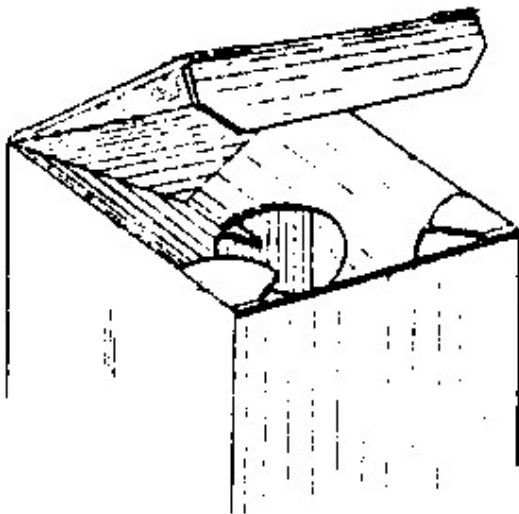

References

Limiting references

This place does not cover:

Formed as an extension of the end closures	B65D 5/5004
--	-----------------------------

B65D 5/5016

{formed by folding inwardly of extensions hinged to the side edges of the body}

Definition statement

This place covers:

Illustrative example of subject matter classified in this group:

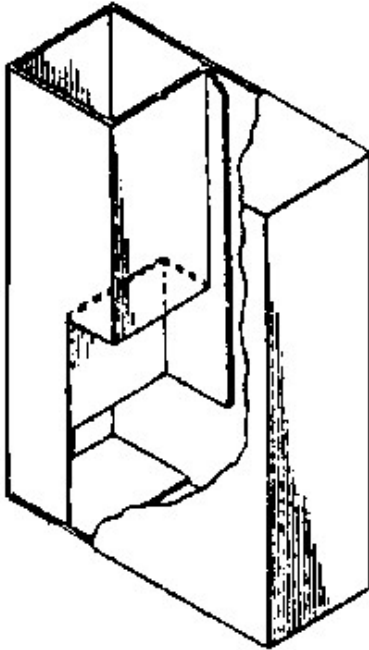

References

Informative references

Attention is drawn to the following places, which may be of interest for search:

Formed by folding extension hinged to the side edges of a tubular body	B65D 5/48014
--	------------------------------

B65D 5/5019

{formed by openings in the body walls}

Definition statement

This place covers:

Illustrative example of subject matter classified in this group:

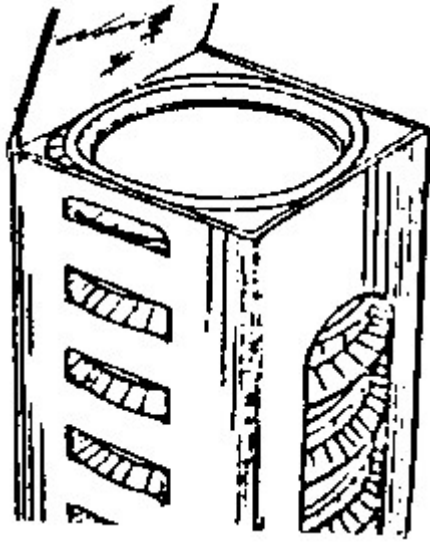
**References*****Informative references***

Attention is drawn to the following places, which may be of interest for search:

With end closures formed by inward-folding of portions of body	B65D 5/08
--	---------------------------

B65D 5/5021

{Integral elements for containers formed by folding-up portions connected to a central panel from all sides}

Definition statement

This place covers:

Illustrative example of subject matter classified in this group:

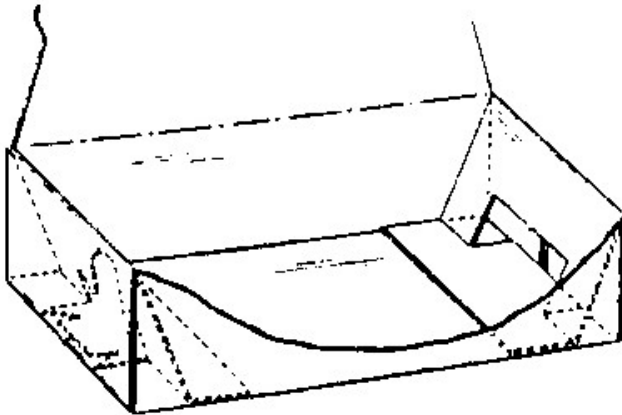

B65D 5/5023

{Integral elements for containers of other type, e.g. formed by folding a blank to U-shape}

Definition statement

This place covers:

Illustrative example of subject matter classified in this group:

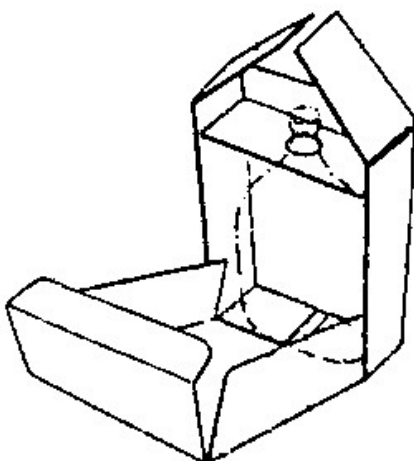

B65D 5/5026**{Hollow frame-like elements surrounding the object}****Definition statement***This place covers:*

Illustrative example of subject matter classified in this group:

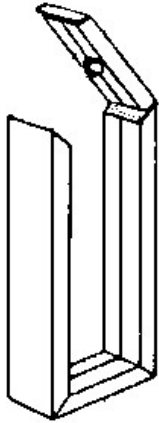
**B65D 5/5028****{Elements formed separately from the container body}****References*****Informative references****Attention is drawn to the following places, which may be of interest for search:*

Devices to locate articles in containers	B65D 25/10
Elements or devices for locating or protecting articles	B65D 77/26
Using resilient suspension means	B65D 81/07

B65D 5/503

{Tray-like elements formed in one piece (formed by folding a blank [B65D 5/5038](#))}

Definition statement

This place covers:

Illustrative example of subject matter classified in this group:

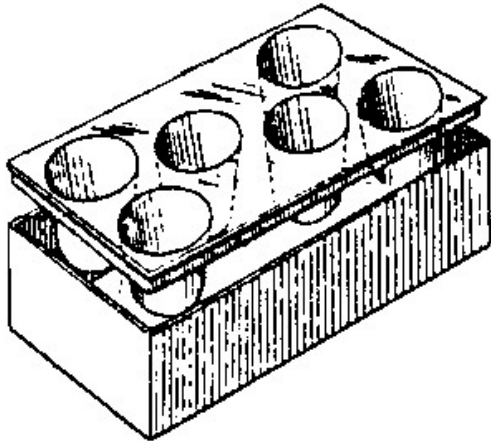
**References****Informative references**

Attention is drawn to the following places, which may be of interest for search:

Trays or like shallow containers with moulded compartments or partitions	B65D 1/36
The inner container being a tray or like shallow container, not formed by folding or erecting one or more blanks	B65D 77/0433
Of a shape specially adapted to accommodate contents	B65D 81/133

B65D 5/5033**{Corner pads or corner posts}****Definition statement***This place covers:*

Illustrative example of subject matter classified in this group:

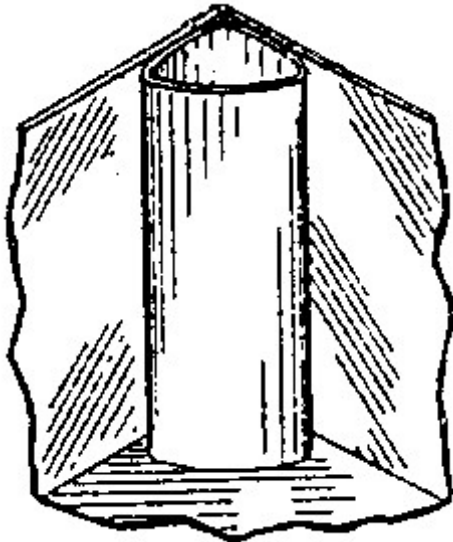
**References****Informative references***Attention is drawn to the following places, which may be of interest for search:*

Reinforcements formed separately from the container	B65D 5/445
Specially adapted to protect contents from mechanical damage	B65D 81/02
Corner, edge or end protectors	B65D 81/053

B65D 5/5035**{Paper elements (in combination with wooden elements [B65D 5/5095](#))}****References****Limiting references***This place does not cover:*

Internal heat-shrinkable sheets for maintaining the contents	B65D 5/5028
--	-----------------------------

Informative references*Attention is drawn to the following places, which may be of interest for search:*

Maintaining contents at spaced relation from package walls, or from other contents	B65D 81/05
--	----------------------------

B65D 5/5038

{Tray-like elements formed by folding a blank and presenting openings or recesses (without external box [B65D 71/72](#); external face of container provided with opening for receiving object in display position [B65D 5/5286](#))}

Definition statement

This place covers:

Illustrative example of subject matter classified in this group:

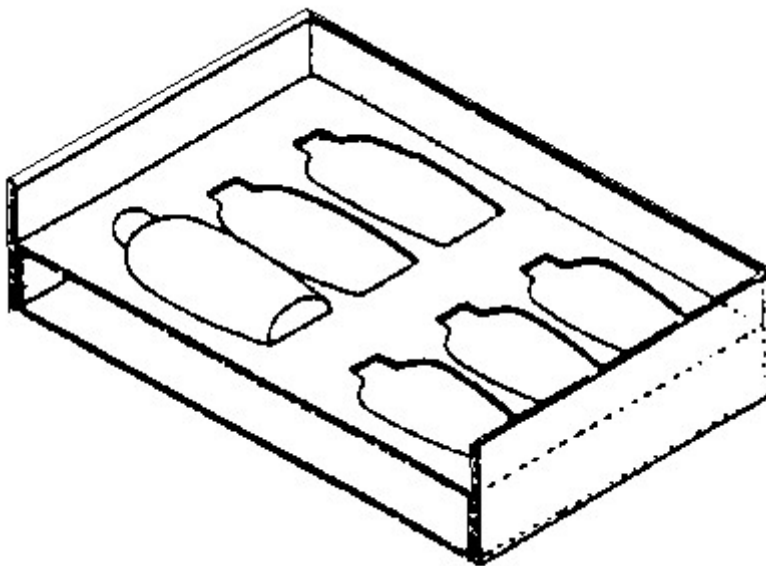

References

Informative references

Attention is drawn to the following places, which may be of interest for search:

Devices e.g. plates	B65D 25/108
---------------------	-----------------------------

B65D 5/504

{Racks having upstanding ridges formed by folds, and provided with slits or recesses}

Definition statement

This place covers:

Illustrative example of subject matter classified in this group:

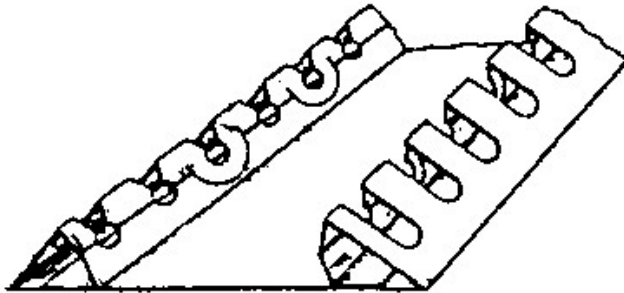
**References****Informative references**

Attention is drawn to the following places, which may be of interest for search:

Integral elements for containers formed by folding-up portions connected to a central panel from all sides	B65D 5/5021
--	-----------------------------

B65D 5/5042

{Hollow tubular elements provided with slits or openings}

Definition statement

This place covers:

DELETED: Transferred to [B65D 5/5052](#)

B65D 5/5045

{Tubular lining and supporting elements}

Definition statement

This place covers:

Illustrative example of subject matter classified in this group:

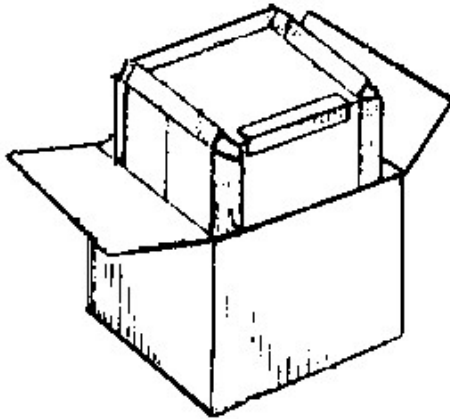

References

Limiting references

This place does not cover:

Edge or corner protectors	B65D 81/053
---------------------------	-----------------------------

B65D 5/505

{formed by folding up one or more blanks to form a hollow block}

Definition statement

This place covers:

Illustrative example of subject matter classified in this group:

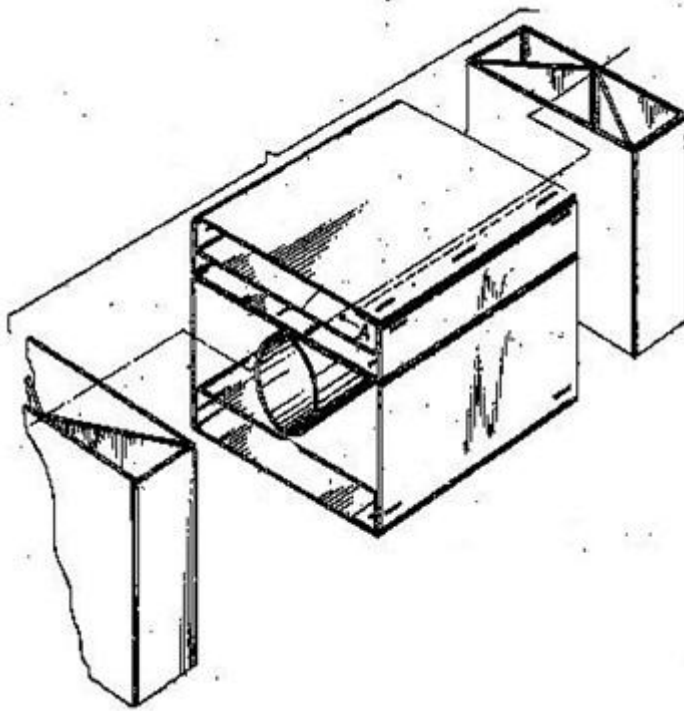

B65D 5/5052

{and provided with slits or recesses in which at least a part of the contents are located ([B65D 5/504](#) takes precedence)}

Definition statement

This place covers:

Illustrative example of subject matter classified in this group:

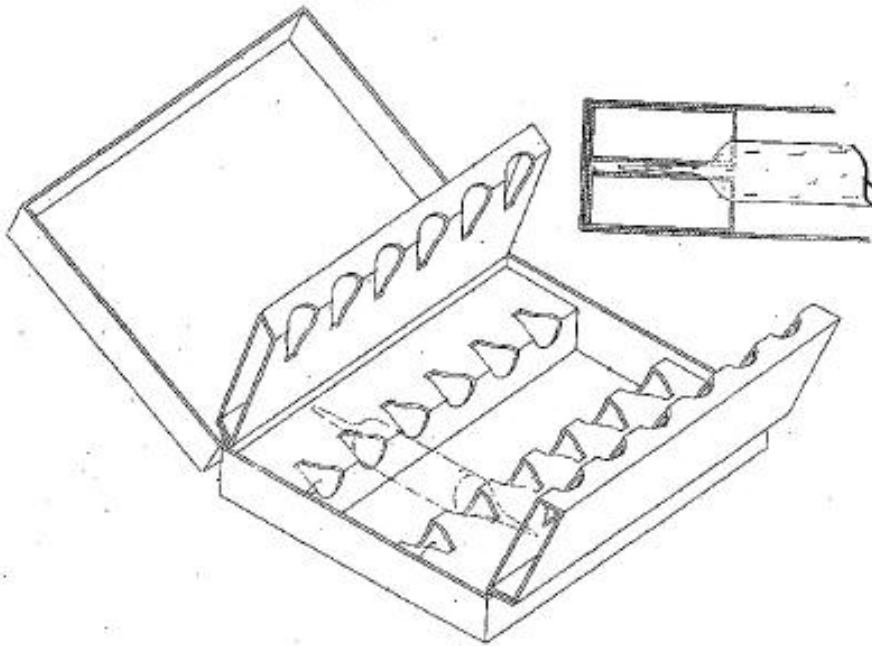
**References****Limiting references**

This place does not cover:

Racks having upstanding ridges formed by folds, and provided with slits or recesses	B65D 5/504
---	----------------------------

B65D 5/5054

{formed by a plurality of layers contacting each other, e.g. multiple layers of corrugated cardboard}

Definition statement

This place covers:

Illustrative example of subject matter classified in this group:

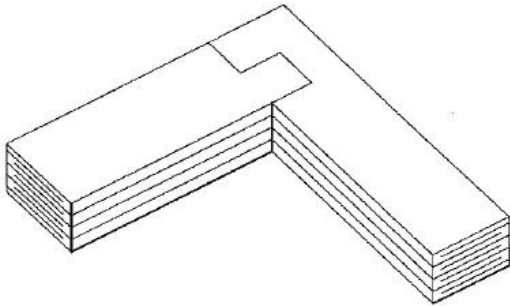

B65D 5/5057

{and provided with slits or recesses in which at least a part of the contents are located}

Definition statement

This place covers:

Illustrative example of subject matter classified in this group:

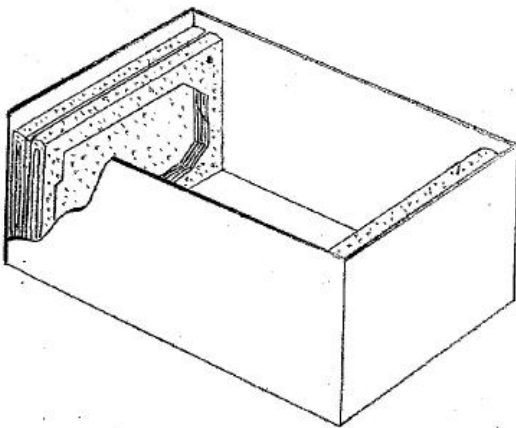

B65D 5/5059

{Paper panels presenting one or more openings or recesses in which at least a part of the contents are located ([B65D 5/5038](#), [B65D 5/5052](#), [B65D 5/5057](#) and [B65D 5/5286](#) take precedence)}

Definition statement

This place covers:

Illustrative example of subject matter classified in this group:

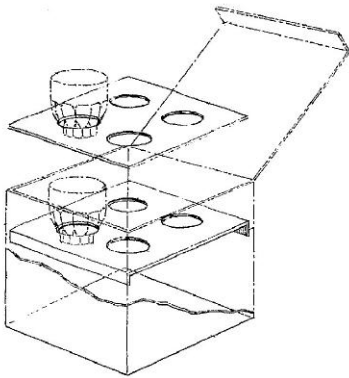

References

Limiting references

This place does not cover:

Tray-like elements formed by folding a blank and presenting openings or recesses	B65D 5/5038
Provided with slits or recesses in which at least a part of the contents are located	B65D 5/5052
Provided with slits or recesses in which at least a part of the contents are located	B65D 5/5057
The container being provided with an opening or weakened area in which an item is inserted	B65D 5/5286

B65D 5/5061

{the openings or recesses being located in different panels of a single blank
([B65D 5/5066](#) takes precedence)}

Definition statement

This place covers:

Illustrative example of subject matter classified in this group:

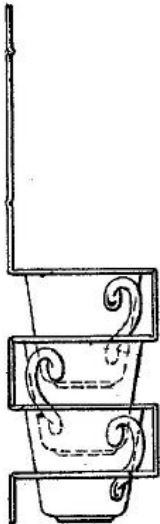
**References****Limiting references**

This place does not cover:

Paper elements formed by folding or assembling two or more panels to create a central aperture extending in at least two planes in which the contents are located	B65D 5/5066
---	-----------------------------

B65D 5/5064

{Inverted U- or V-shaped paper elements provided with slits or recesses in which at least a part of the contents are located ([B65D 5/504](#) and [B65D 5/5052](#) takes precedence)}

Definition statement

This place covers:

Illustrative example of subject matter classified in this group:

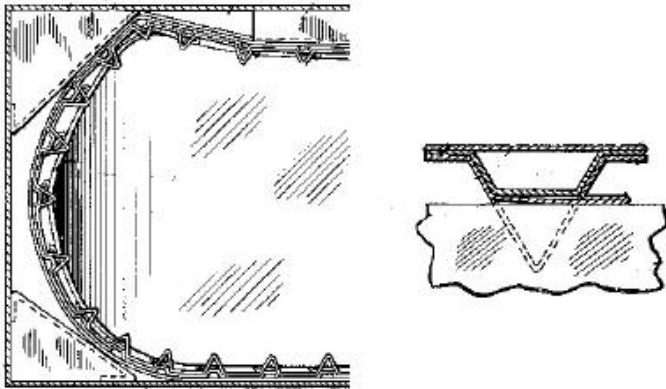
**References****Limiting references**

This place does not cover:

Racks having upstanding ridges formed by fold, and provided with slits and recesses	B65D 5/504
Provided with slits or recesses in which at least a part of the contents are located	B65D 5/5052

B65D 5/5066

{Paper elements formed by folding or assembling two or more panels to create a central aperture extending in at least two planes in which the contents are located}

Definition statement

This place covers:

Illustrative example of subject matter classified in this group:

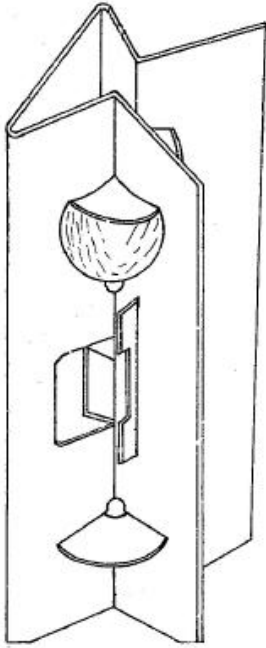

B65D 5/5069

{Capping elements, i.e. elements which are located onto one or more ends of the contents, before the contents are inserted into the package}

Definition statement

This place covers:

Illustrative example of subject matter classified in this group:

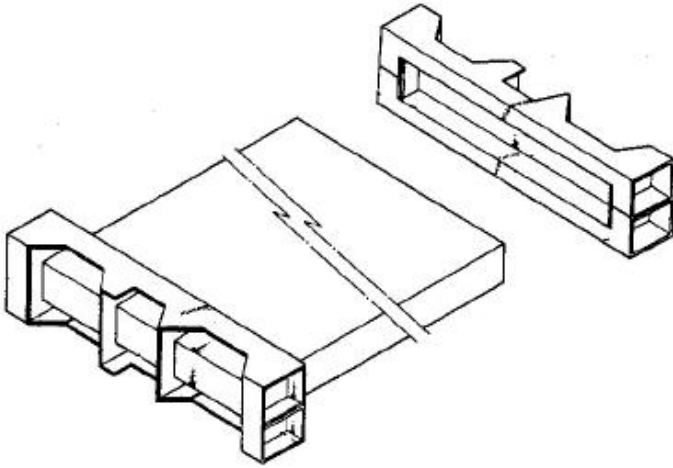

B65D 5/5071

{each capping element being formed by assembling two or more blanks}

Definition statement

This place covers:

Illustrative example of subject matter classified in this group:

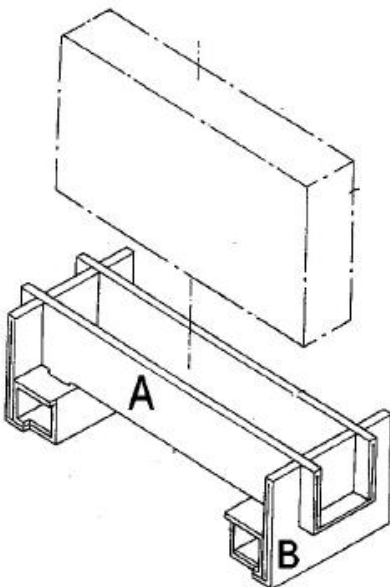

B65D 5/5073

{U-shaped elements supporting the articles locally at their sides}

Definition statement

This place covers:

Illustrative example of subject matter classified in this group:

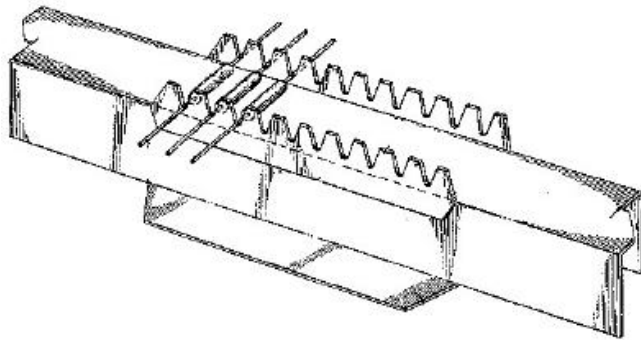
**B65D 5/5076**

{U-shaped elements supporting the articles along substantially their whole length, e.g. a cradle ([B65D 5/508](#) takes precedence)}

Definition statement

This place covers:

Illustrative example of subject matter classified in this group:

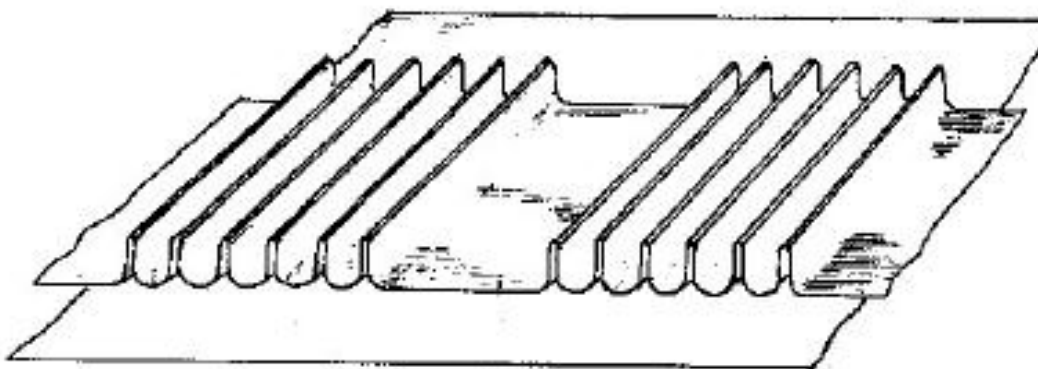
**References****Limiting references**

This place does not cover:

Combination of U-shaped and inverted U-shaped elements	B65D 5/508
--	----------------------------

B65D 5/5078

{Pockets whereby the articles are inserted into the pockets, e.g. inverted U-shaped elements ([B65D 5/508](#) takes precedence)}

Definition statement

This place covers:

Illustrative example of subject matter classified in this group:

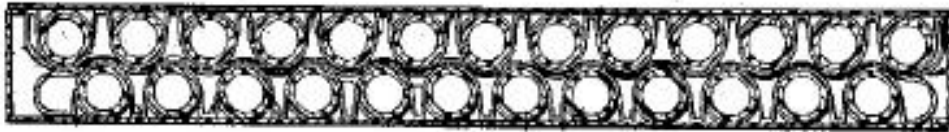
**References****Limiting references**

This place does not cover:

Combination of U-shaped and inverted U-shaped elements	B65D 5/508
--	----------------------------

B65D 5/508

{Combination of U-shaped and inverted U-shaped elements}

Definition statement

This place covers:

Illustrative example of subject matter classified in this group:



B65D 5/5083

{each item being partially located in a U-shaped element and partially located in an inverted U-shaped element, e.g. for bottles}

Definition statement

This place covers:

Illustrative example of subject matter classified in this group:

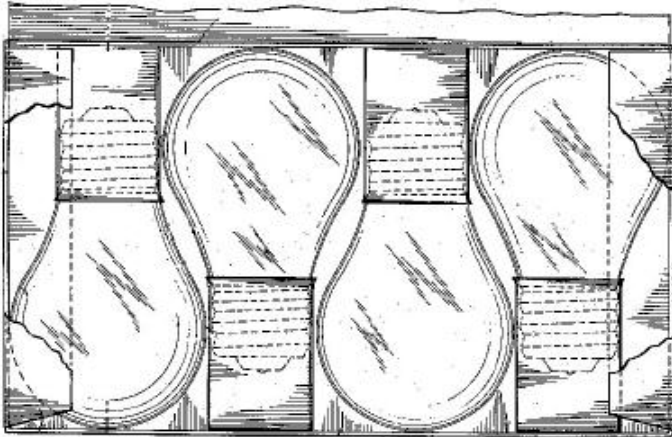
**B65D 5/5085**

{the elements forming grooves, ribs, or the like, situated on opposed walls and between which the articles are located (for rigid containers [B65D 25/107](#))}

Definition statement

This place covers:

Illustrative example of subject matter classified in this group:

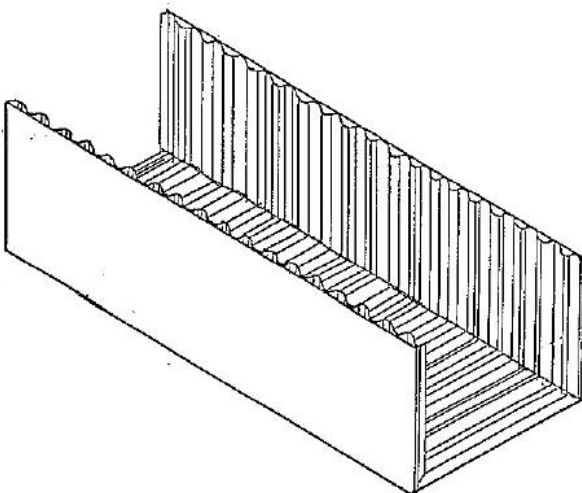

B65D 5/5088

{Plastic elements (trays [B65D 5/503](#))}

Definition statement

This place covers:

Illustrative example of subject matter classified in this group:

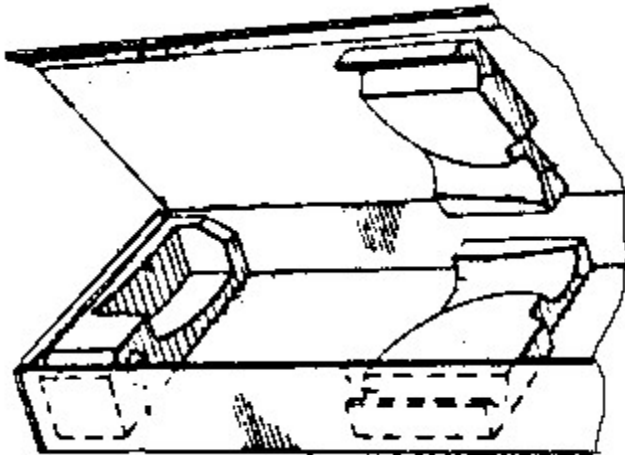

B65D 5/509

{Foam plastic elements}

Definition statement

This place covers:

Illustrative example of subject matter classified in this group:

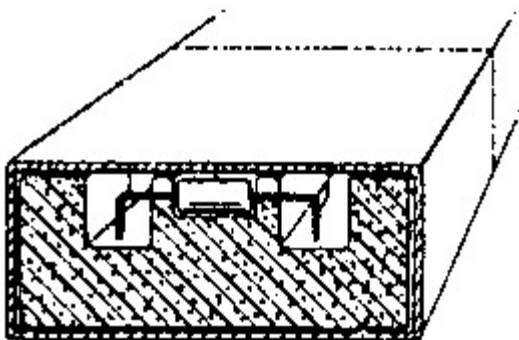

B65D 5/5092

{Wooden elements}

Definition statement

This place covers:

Illustrative example of subject matter classified in this group:

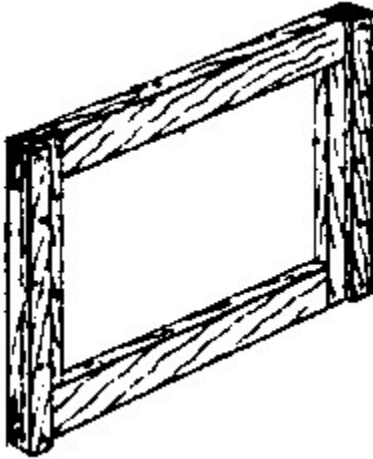

B65D 5/5095

{Wooden elements in combination with paper elements}

Definition statement

This place covers:

Illustrative example of subject matter classified in this group:

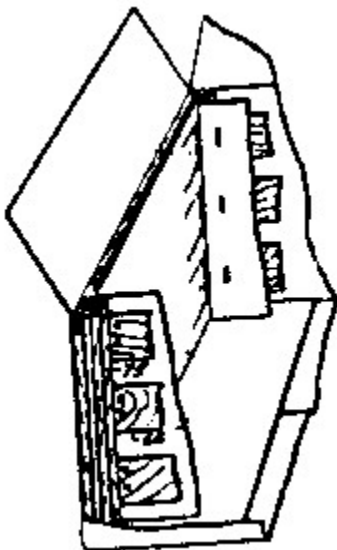

B65D 5/5097

{Central hubs or shafts}

Definition statement

This place covers:

Illustrative example of subject matter classified in this group:

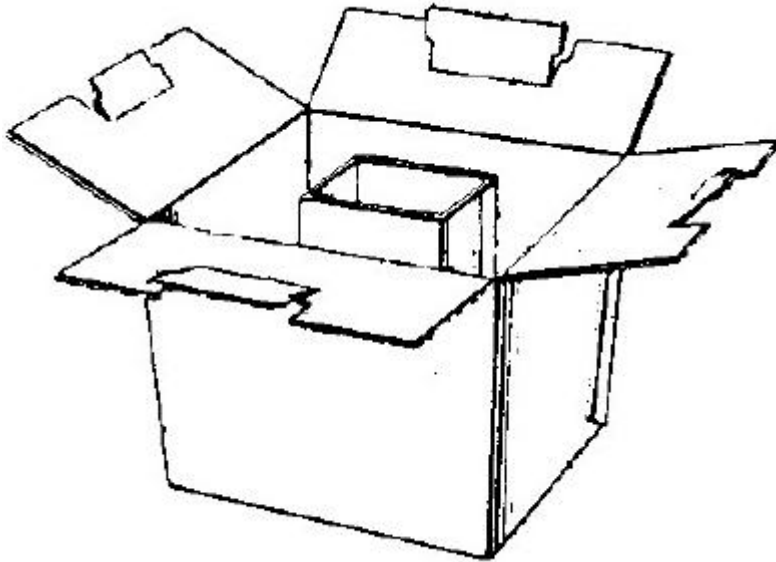

B65D 5/52

External stands or display elements for contents

Definition statement

This place covers:

Illustrative example of subject matter classified in this group:

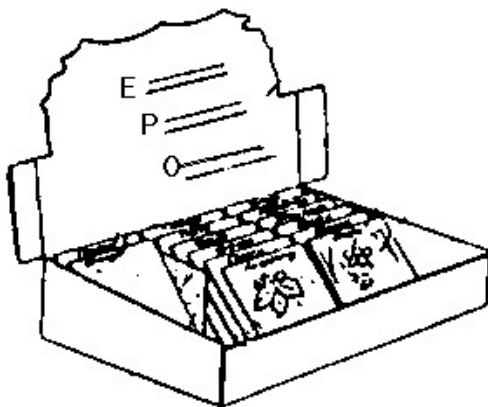

B65D 5/5206

{External stands for supporting the container in display position, e.g. easels, covers forming a support for the containers in the display position}

Definition statement

This place covers:

Illustrative example of subject matter classified in this group:

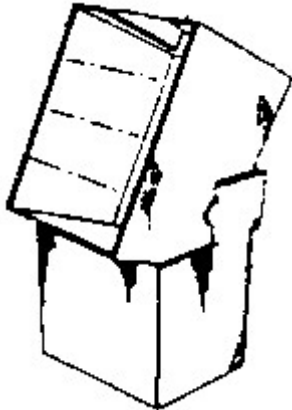

B65D 5/5213

{Internal elements supporting the contents and movable for displaying them, e.g. movable bottoms or trays}

Definition statement

This place covers:

Illustrative example of subject matter classified in this group:

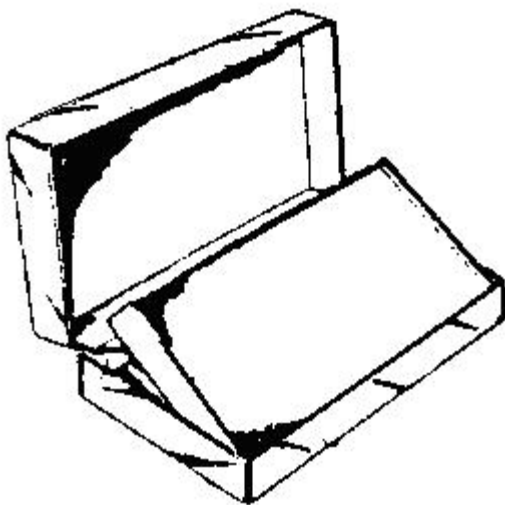

B65D 5/5226

{formed integrally with the container or lid ([B65D 5/526](#) takes precedence)}

References**Limiting references**

This place does not cover:

Containers with means for displaying items at different heights	B65D 5/526
---	----------------------------

B65D 5/5233

{Display panels located within the upper surface of the container and being raised to simultaneously provide a dispensing opening}

Definition statement

This place covers:

Information or decoration panels with means for maintaining them in the raised, display position

Illustrative example of subject matter classified in this group:

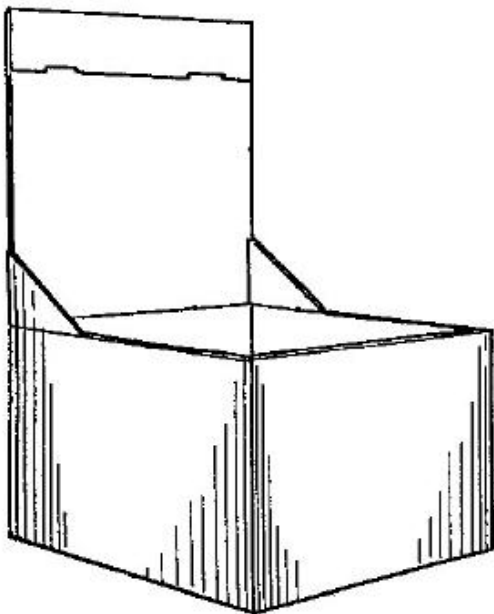

B65D 5/524

{the panel in the raised position being folded about itself}

Definition statement

This place covers:

Illustrative example of subject matter classified in this group:

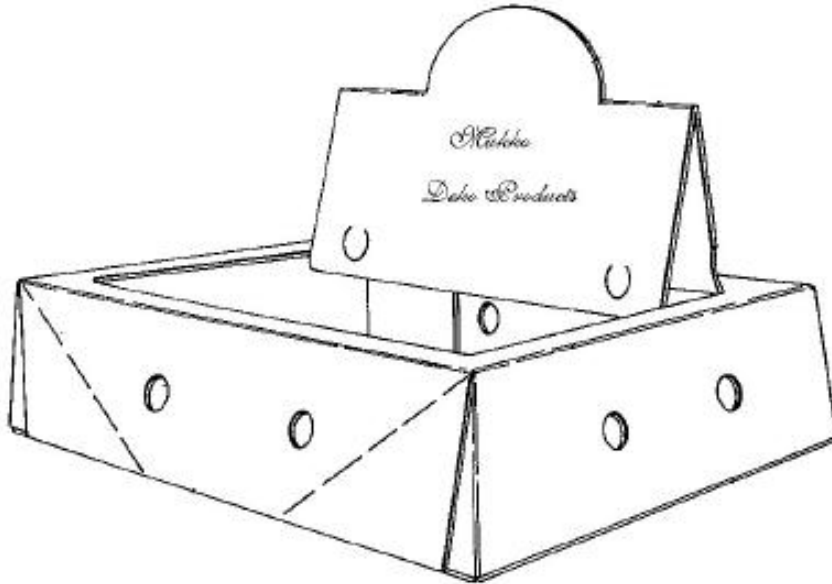

B65D 5/5246

{formed separately from the container or lid}

Definition statement

This place covers:

Illustrative example of subject matter classified in this group:

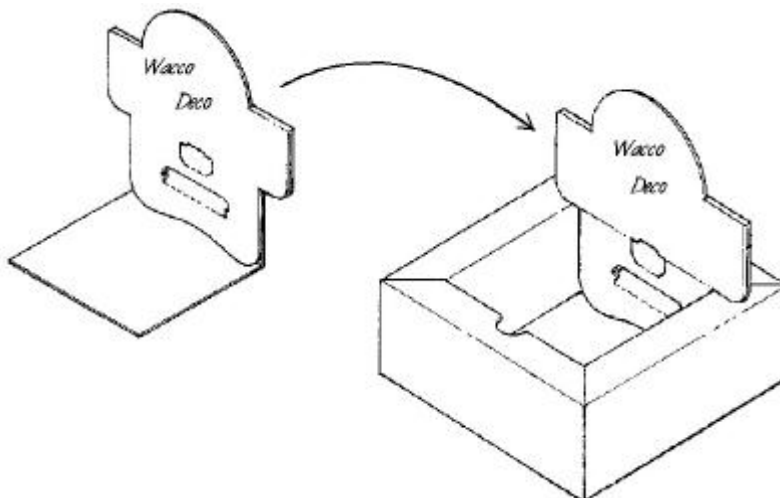

B65D 5/5253

{Containers initially closed but folded about a central axis to display the contents in two or more cells}

Definition statement

This place covers:

Illustrative example of subject matter classified in this group:

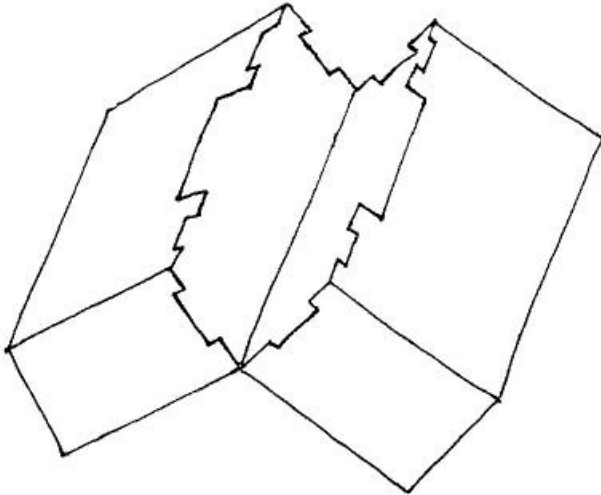

B65D 5/526

{Containers with means for displaying items at different heights}

Definition statement

This place covers:

Illustrative example of subject matter classified in this group:

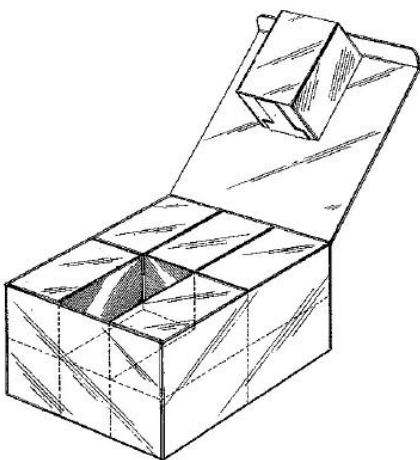

B65D 5/5266

{in tiered or stepped relationship ([B65D 5/5206](#) takes precedence)}

Definition statement

This place covers:

Illustrative example of subject matter classified in this group:

**References****Limiting references**

This place does not cover:

External strands for supporting the container in display position	B65D 5/5206
---	-----------------------------

B65D 5/5273

{Containers provided with an inclined surface on which the contents are located ([B65D 5/5213](#), [B65D 5/5266](#) take precedence)}

Definition statement

This place covers:

Illustrative example of subject matter classified in this group:

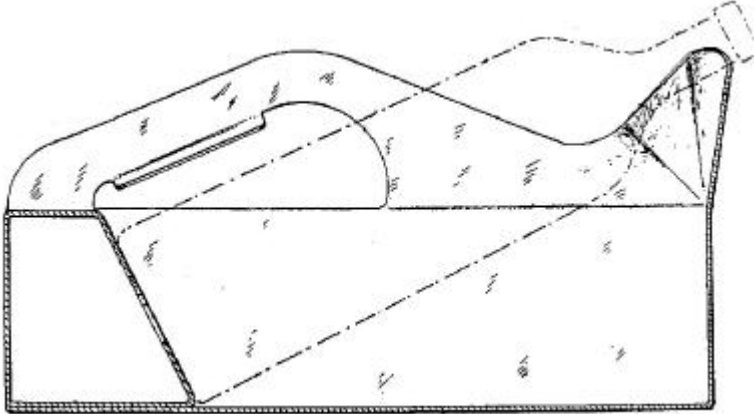
**References****Limiting references**

This place does not cover:

Internal elements supporting the contents and movable for displaying them	B65D 5/5213
In tiered or stepped relationship	B65D 5/5266

B65D 5/528

{Contents attached to or resting on the external surface of the container}

Definition statement

This place covers:

Illustrative example of subject matter classified in this group:

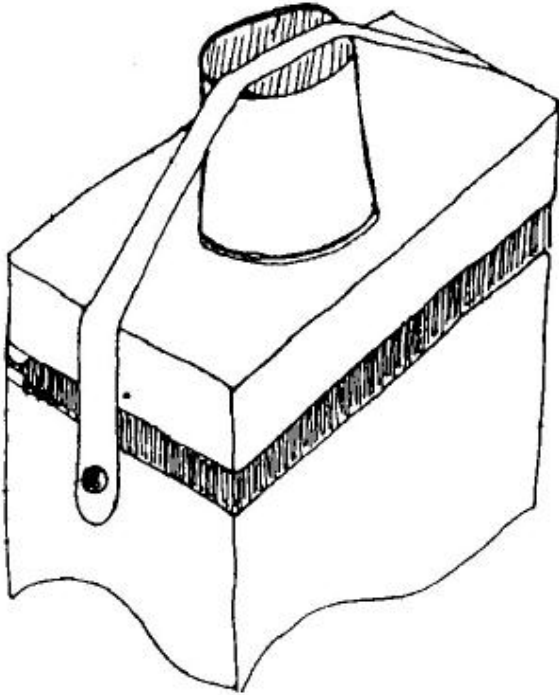

B65D 5/5286

{the container being provided with an opening or weakened area in which an item is inserted}

Definition statement

This place covers:

Illustrative example of subject matter classified in this group:

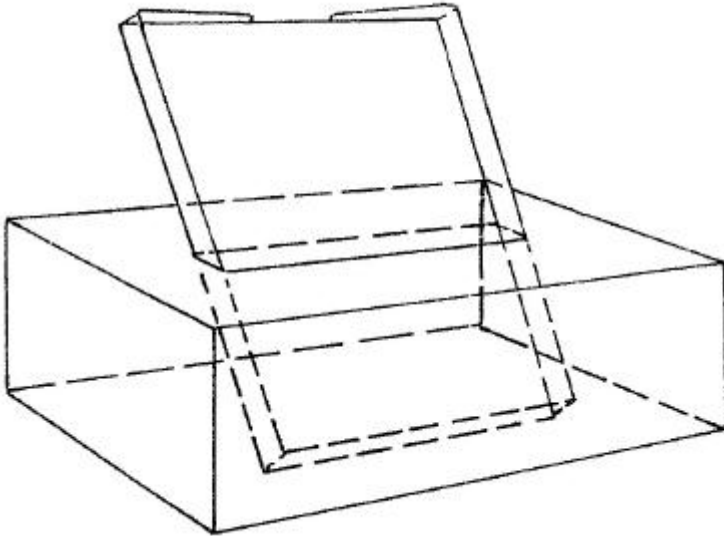

B65D 5/5293

{the container being provided with U- or V-shaped racks on which the items rest}

Definition statement

This place covers:

Illustrative example of subject matter classified in this group:

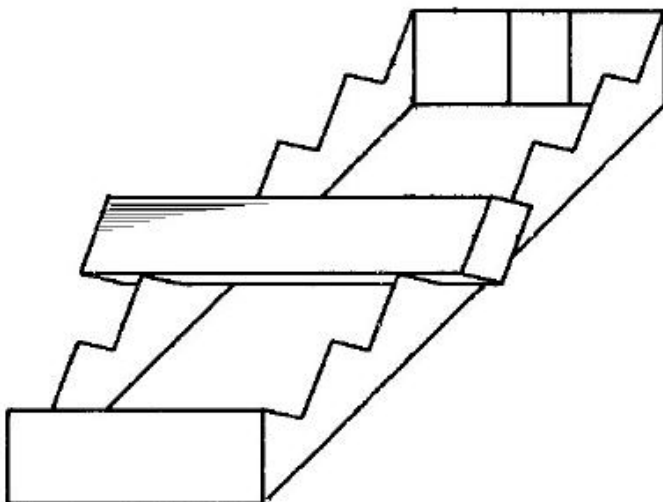

B65D 5/54

Lines of weakness to facilitate opening of container or dividing it into separate parts by cutting or tearing ([B65D 5/06](#), [B65D 5/5233](#), [B65D 5/5253](#) take precedence) ; break-in flaps, or members adapted to be torn-off, to provide pouring openings [B65D 5/70](#))

References**Limiting references**

This place does not cover:

With end-closing or contents-supporting elements formed by folding inwardly a wall extending from, and continuously around, an end of the tubular body	B65D 5/06
Tear strips for other purposes	B65D 5/4266
Display panels located within the upper surface of the container and being raised to simultaneously provide a dispensing opening	B65D 5/5233
Containers initially closed but folded about a central axis to display the contents in two or more cells	B65D 5/5253

B65D 5/541

{the lines of weakness being provided in one or more closure flaps}

Definition statement

This place covers:

Illustrative example of subject matter classified in this group:

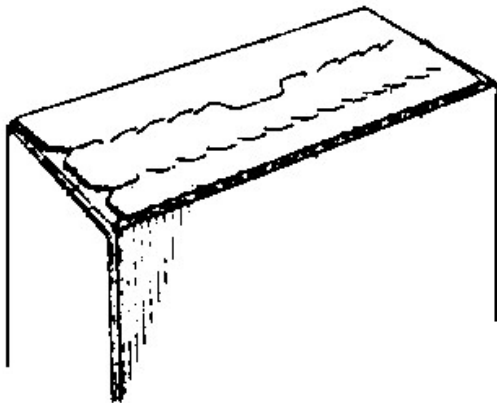

B65D 5/5415

{the lines of weakness being provided in one or more closure flaps and in the container body so as to form after rupture a lid hinged to a side edge of the container body}

Definition statement

This place covers:

Illustrative example of subject matter classified in this group:

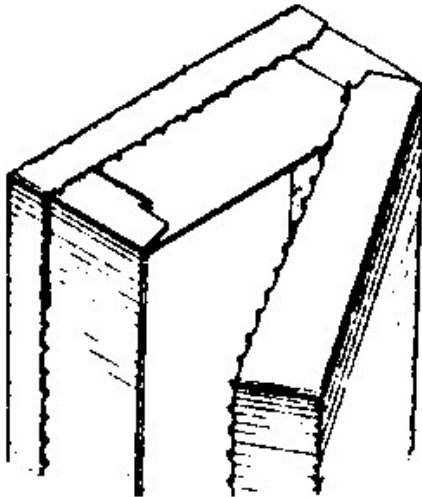

References

Informative references

Attention is drawn to the following places, which may be of interest for search:

The lines of weakness being provided in an extension panel or tab of a hinged closure	B65D 5/546
---	----------------------------

B65D 5/542

{the lines of weakness being provided in the container body}

Definition statement

This place covers:

Illustrative example of subject matter classified in this group:

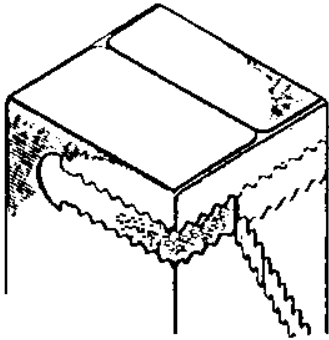
**B65D 5/5425**

{and defining after rupture a lid hinged to the upper edge of the container body}

Definition statement

This place covers:

Illustrative example of subject matter classified in this group:

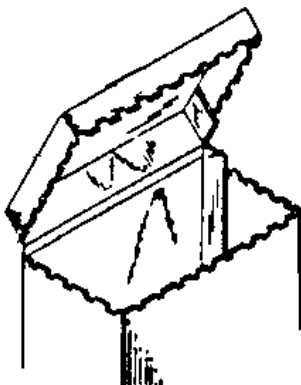
**References****Informative references**

Attention is drawn to the following places, which may be of interest for search:

Containers formed by erecting a rigid or semi-rigid blank	B65D 85/1036
---	------------------------------

B65D 5/543

{the container being provided with an internal frame or the like for maintaining the lid in the closed position by friction}

Definition statement

This place covers:

Illustrative example of subject matter classified in this group:

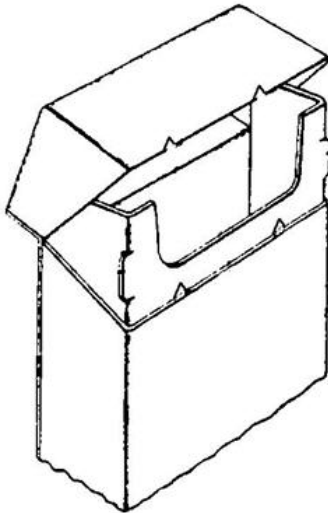
**References****Informative references**

Attention is drawn to the following places, which may be of interest for search:

For opening containers formed by erecting a "cross-like" blank, the container being provided with an internal frame or the like for maintaining the lid in the closed position by friction	B65D 5/5465
For opening containers formed by erecting a blank to U-shape, the container being provided with an internal frame or the like for maintaining the lid in the closed position by friction	B65D 5/5485
Linings made of relatively rigid sheet material	B65D 5/566
Formed by folding one or more extensions hinged to the upper edge of a tubular container body, the container being provided with an internal frame or the like for maintaining the lid in the closed position by friction	B65D 5/662
Formed by folding extensions of a side panel of a container body formed by erecting a "cross-like" blank, the container being provided with an internal frame or the like for maintaining the lid in the closed position by friction	B65D 5/6679
Formed by extensions hinged to the upper edge of a container body formed by erecting a blank to U-shape, the container being provided with an internal frame or the like for maintaining the lid in the closed position by friction	B65D 5/6691

B65D 5/5435

{and defining after rupture a lid hinged to the side edge of the container body}

Definition statement

This place covers:

Illustrative example of subject matter classified in this group:

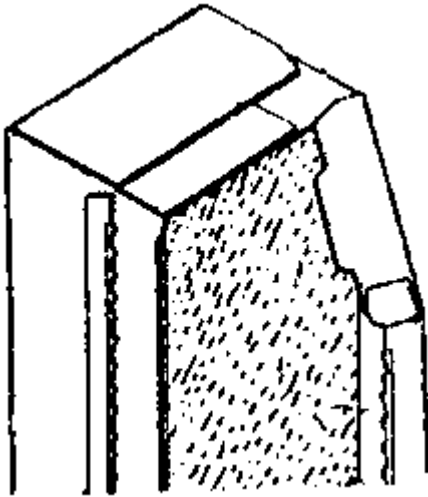

B65D 5/544

{and defining after rupture a lid hinged about a line located in the top surface of the container}

Definition statement

This place covers:

Illustrative example of subject matter classified in this group:

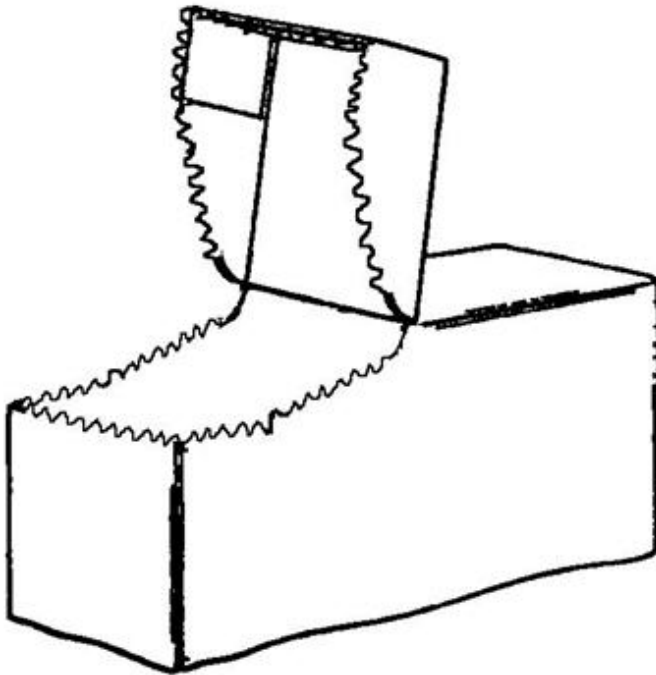
**References****Informative references**

Attention is drawn to the following places, which may be of interest for search:

For opening containers formed by erecting a "cross-like" blank and defining after rupture a lid hinged about a line located in the top surface of the container	B65D 5/547
For opening containers formed by erecting a blank to U-shape and defining after rupture a lid hinged about a line located in the top surface of the container	B65D 5/549
Formed by folding one or more extensions hinged to the upper edge of a tubular container body, the lid being hinged about a line located in the top surface of the container	B65D 5/6623
Formed by folding extensions of a side panel of a container body formed by erecting a "cross-like" blank, the lid being hinged about a line located in the top surface of the container	B65D 5/6682
Formed by extensions hinged to the upper edge of a container body formed by erecting a blank to U-shape, the lid being hinged about a line located in the top surface of the container	B65D 5/6694

B65D 5/5445

{for dividing a tubular body into separate parts}

Definition statement

This place covers:

Illustrative example of subject matter classified in this group:

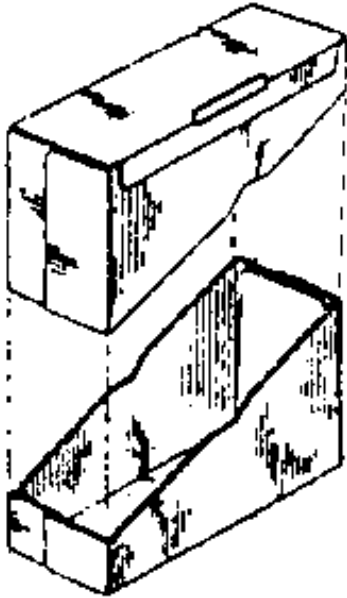

B65D 5/5455

{the lines of weakness being provided in a closure hinged to an edge of the container body}

Definition statement

This place covers:

Illustrative example of subject matter classified in this group:

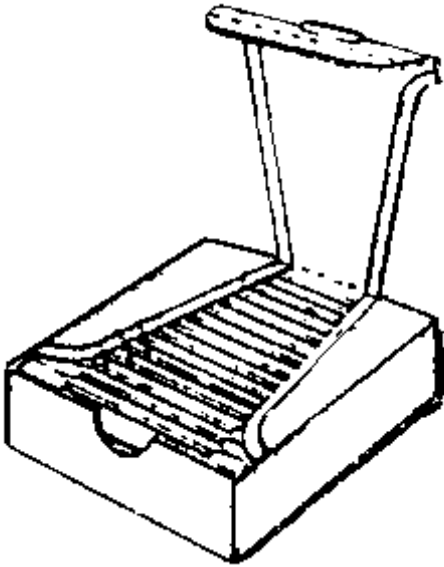

References

Informative references

Attention is drawn to the following places, which may be of interest for search:

Containers formed by erecting a rigid or semi-rigid blank

B65D 85/1036

B65D 5/546

{the lines of weakness being provided in an extension panel or tab of a hinged closure}

Definition statement

This place covers:

Illustrative example of subject matter classified in this group:

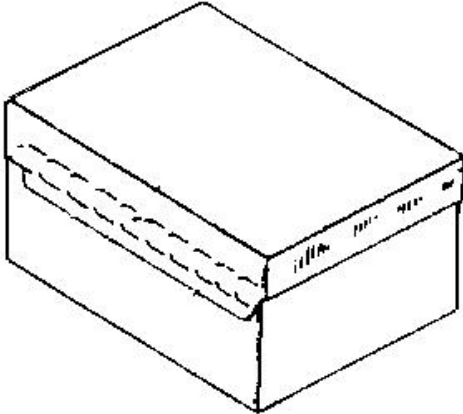

References

Informative references

Attention is drawn to the following places, which may be of interest for search:

The lines of weakness being provided in one or more closure flaps and in the container body so as to form after rupture a lid hinged to a side edge of the container body

B65D 5/5415

B65D 5/5465

{the container being provided with an internal frame or the like for maintaining the lid in the closed position by friction}

Definition statement

This place covers:

Illustrative example of subject matter classified in this group:

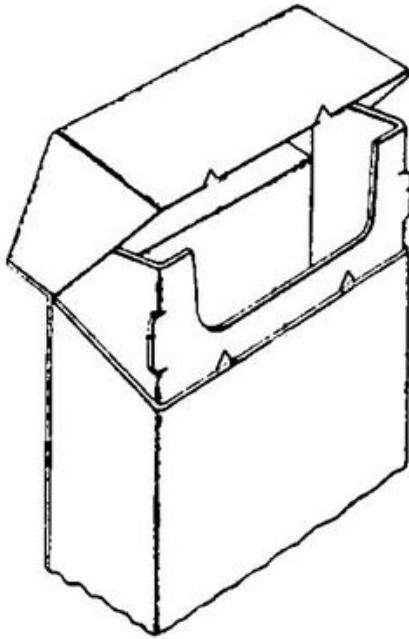
**References****Informative references**

Attention is drawn to the following places, which may be of interest for search:

The lines of weakness being provided in the container body, defining after rupture a lid hinged to the upper edge of the container body, the container being provided with an internal frame or the like for maintaining the lid in the closed position by friction	B65D 5/543
For opening containers formed by erecting a blank to U-shape, the container being provided with an internal frame or the like for maintaining the lid in the closed position by friction	B65D 5/5485
Formed by folding one or more extensions hinged to the upper edge of a tubular container body, the container being provided with an internal frame or the like for maintaining the lid in the closed position by friction	B65D 5/662
Formed by folding extensions of a side panel of a container body formed by erecting a "cross-like" blank, the container being provided with an internal frame or the like for maintaining the lid in the closed position by friction	B65D 5/6679
Formed by extensions hinged to the upper edge of a container body formed by erecting a blank to U-shape, the container being provided with an internal frame or the like for maintaining the lid in the closed position by friction	B65D 5/6691

B65D 5/547

{and defining after rupture a lid hinged about a line located in the top surface of the container}

Definition statement

This place covers:

Illustrative example of subject matter classified in this group:

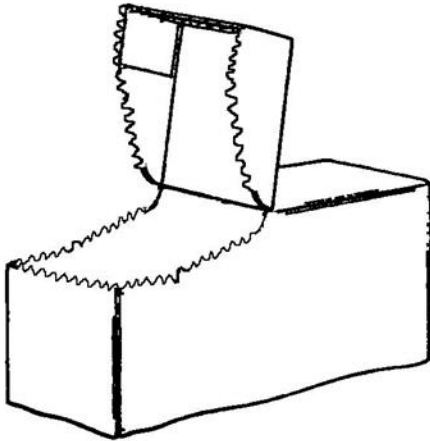
**References****Informative references**

Attention is drawn to the following places, which may be of interest for search:

For opening containers formed by erecting a blank in tubular form, the lines of weakness being provided in the container body, and defining after rupture a lid hinged about a line located in the top surface of the container	B65D 5/544
For opening containers formed by erecting a blank to U-shape and defining after rupture a lid hinged about a line located in the top surface of the container	B65D 5/549
Formed by folding one or more extensions hinged to the upper edge of a tubular container body, the lid being hinged about a line located in the top surface of the container	B65D 5/6623
Formed by folding extensions of a side panel of a container body formed by erecting a "cross-like" blank, the lid being hinged about a line located in the top surface of the container	B65D 5/6682
Formed by extensions hinged to the upper edge of a container body formed by erecting a blank to U-shape, the lid being hinged about a line located in the top surface of the container	B65D 5/6694

B65D 5/5475

{for dividing a "cross-like" container body into separate parts}

Definition statement

This place covers:

Illustrative example of subject matter classified in this group:

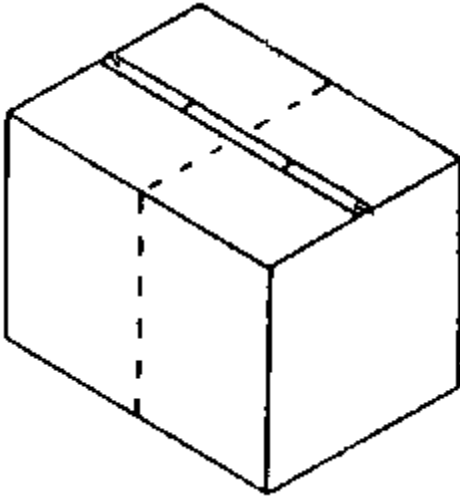

B65D 5/548

{for opening containers formed by erecting a blank to U-shape}

Definition statement

This place covers:

Illustrative example of subject matter classified in this group:

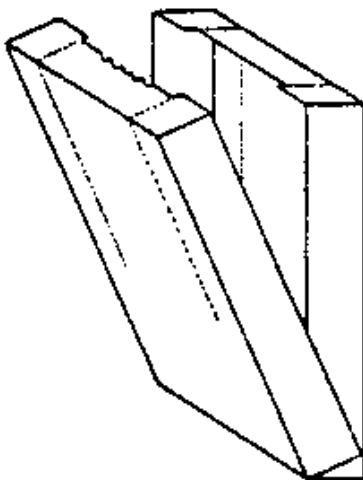

B65D 5/5485

{the container being provided with an internal frame or the like for maintaining the lid in the closed position by friction}

Definition statement

This place covers:

Illustrative example of subject matter classified in this group:

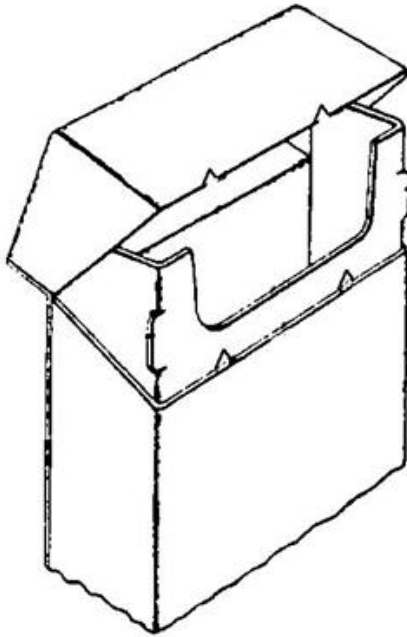
**References****Informative references**

Attention is drawn to the following places, which may be of interest for search:

The lines of weakness being provided in the container body, defining after rupture a lid hinged to the upper edge of the container body, the container being provided with an internal frame or the like for maintaining the lid in the closed position by friction	B65D 5/543
For opening containers formed by erecting a "cross-like" blank, the container being provided with an internal frame or the like for maintaining the lid in the closed position by friction	B65D 5/5465
Formed by folding one or more extensions hinged to the upper edge of a tubular container body, the container being provided with an internal frame or the like for maintaining the lid in the closed position by friction	B65D 5/662
Formed by folding extensions of a side panel of a container body formed by erecting a "cross-like" blank, the container being provided with an internal frame or the like for maintaining the lid in the closed position by friction	B65D 5/6679
Formed by extensions hinged to the upper edge of a container body formed by erecting a blank to U-shape, the container being provided with an internal frame or the like for maintaining the lid in the closed position by friction	B65D 5/6691

B65D 5/549

{and defining after rupture a lid hinged about a line located in the top surface of the container}

Definition statement

This place covers:

Illustrative example of subject matter classified in this group:

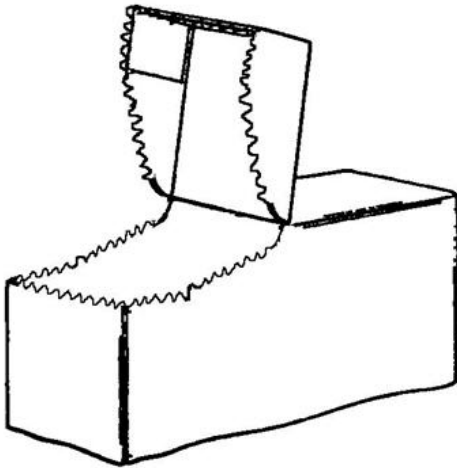
**References****Informative references**

Attention is drawn to the following places, which may be of interest for search:

For opening containers formed by erecting a blank in tubular form, the lines of weakness being provided in the container body, and defining after rupture a lid hinged about a line located in the top surface of the container	B65D 5/544
For opening containers formed by erecting a "cross-like" blank and defining after rupture a lid hinged about a line located in the top surface of the container	B65D 5/547
Formed by folding one or more extensions hinged to the upper edge of a tubular container body, the lid being hinged about a line located in the top surface of the container	B65D 5/6623
Formed by folding extensions of a side panel of a container body formed by erecting a "cross-like" blank, the lid being hinged about a line located in the top surface of the container	B65D 5/6682
Formed by extensions hinged to the upper edge of a container body formed by erecting a blank to U-shape, the lid being hinged about a line located in the top surface of the container	B65D 5/6694

B65D 5/5495

{for separating interconnected containers}

Definition statement

This place covers:

Illustrative example of subject matter classified in this group:

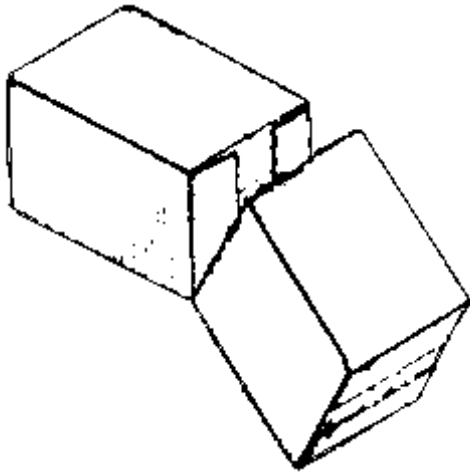

B65D 5/563

{Laminated linings; Coatings}

Definition statement

This place covers:

Illustrative example of subject matter classified in this group:

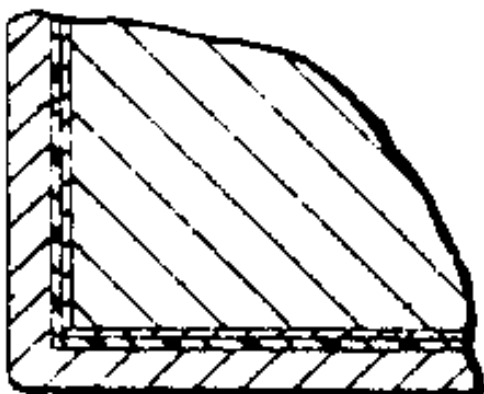

B65D 5/566

{Linings made of relatively rigid sheet material, e.g. carton ([B65D 5/0281](#) and [B65D 5/58](#) takes precedence; combined with a flexible lining [B65D 5/56](#), [B65D 5/60](#); for thermal insulating purposes [B65D 81/3858](#); for shock absorbing purposes [B65D 81/1275](#))}

Definition statement

This place covers:

Illustrative example of subject matter classified in this group:

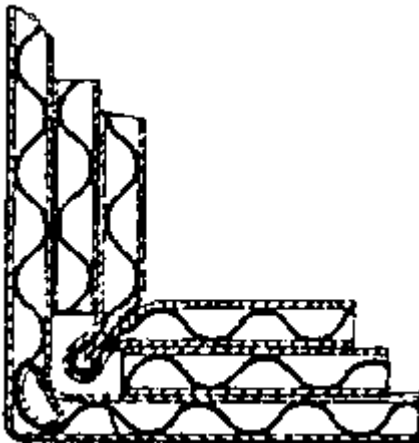

References

Limiting references

This place does not cover:

The tubular body presenting double or multiple walls	B65D 5/0281
Linings spaced appreciably from container wall	B65D 5/58

Informative references

Attention is drawn to the following places, which may be of interest for search:

The lines of weakness being provided in the container body and defining after rupture a lid hinge to the upper edge of the container body, the container being provided with an internal frame or the like for maintaining the lid in the closed position by friction	B65D 5/543
---	----------------------------

B65D 5/58

Linings spaced appreciably from container wall {(for thermal insulating purposes [B65D 81/3853](#))}

Definition statement

This place covers:

Illustrative example of subject matter classified in this group:

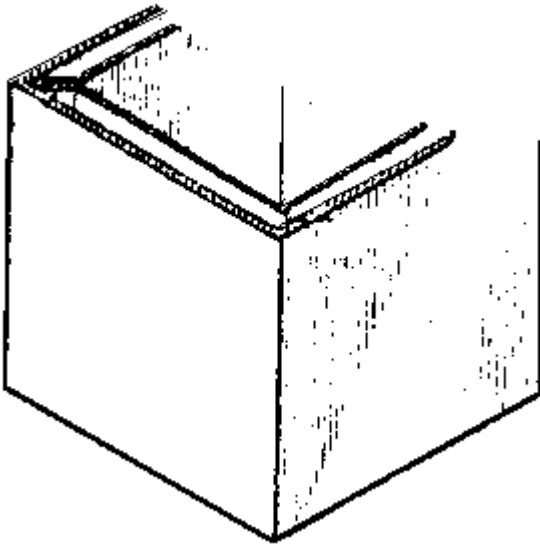
**References****Informative references**

Attention is drawn to the following places, which may be of interest for search:

Paper elements formed separately from the container body	B65D 5/5035
--	-----------------------------

B65D 5/60

Loose, {or loosely attached}, linings {(made only of relatively rigid sheet material [B65D 5/566](#))}

References**Limiting references**

This place does not cover:

Internal heat-shrinkable sheets for maintaining the contents	B65D 5/5028
--	-----------------------------

B65D 5/603

{Flexible linings loosely glued to the wall of the container ([B65D 5/0272](#) takes precedence)}

Definition statement

This place covers:

Illustrative example of subject matter classified in this group:

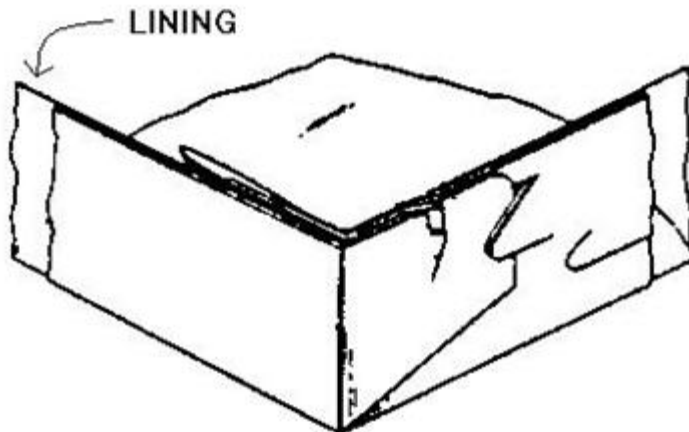
**References****Limiting references**

This place does not cover:

With end closures formed by applying a web on the edge of the body, and subsequent inward folding of flaps	B65D 5/0272
Heat-shrinkable	B65D 5/5028

Informative references

Attention is drawn to the following places, which may be of interest for search:

Loose, or loosely attached, linings	B65D 25/16
-------------------------------------	----------------------------

B65D 5/606

{Bags or bag-like tubes loosely glued to the wall of a "tubular" container}

Definition statement

This place covers:

Illustrative example of subject matter classified in this group:

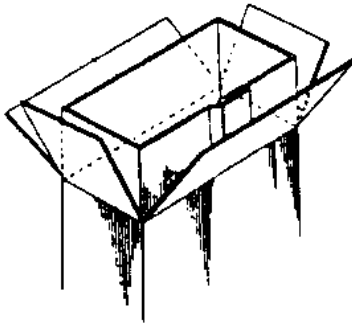
**B65D 5/62**

External coverings or coatings {([B65D 5/4245](#), [B65D 5/4262](#) take precedence)}

Definition statement

This place covers:

Illustrative example of subject matter classified in this group:

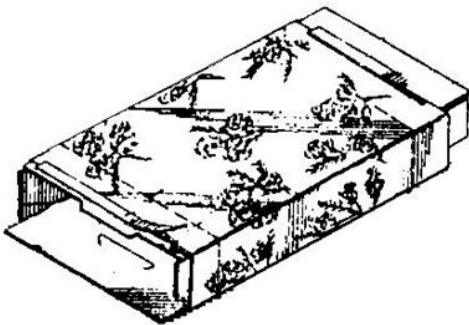
**References****Limiting references**

This place does not cover:

Bands covering at least 3 adjacent faces of a container	B65D 5/4245
Bands covering at least 3 adjacent faces of a container provided with a decoration	B65D 5/4262

Informative references

Attention is drawn to the following places, which may be of interest for search:

Coverings or external coatings	B65D 25/34
--------------------------------	----------------------------

Coverings or external coatings formed by applying sheet material	B65D 25/36
Articles enclosed in rigid or semi-rigid containers, the whole being wrapped	B65D 77/003

B65D 5/64

Lids

References

Informative references

Attention is drawn to the following places, which may be of interest for search:

Having a mesh or apertures closure to allow contents to breathe	B65D 85/345
---	-----------------------------

B65D 5/643

{held in closed position by application of separate elements, e.g. clips, straps
 ([B65D 5/6611](#), [B65D 5/6673](#) take precedence)}

Definition statement

This place covers:

Illustrative example of subject matter classified in this group:

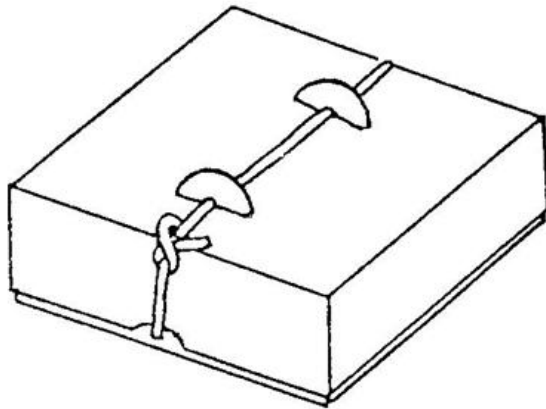

References

Limiting references

This place does not cover:

Hinged lids formed by folding one or more extensions hinged to the upper edge of a tubular container body, the lid being held in position by application of separate elements	B65D 5/6611
Hinged lids formed by folding extensions of a side panel of a container body formed by erecting a "cross-like" blank, the lid being held in position by application of separate elements	B65D 5/6673

Informative references

Attention is drawn to the following places, which may be of interest for search:

Connections formed by separate elements	B65D 5/4283
Telescope flanged lids	B65D 5/68

B65D 5/646

{comprising a slidable panel or wall ([B65D 5/723](#) takes precedence)}

Definition statement

This place covers:

Illustrative example of subject matter classified in this group:

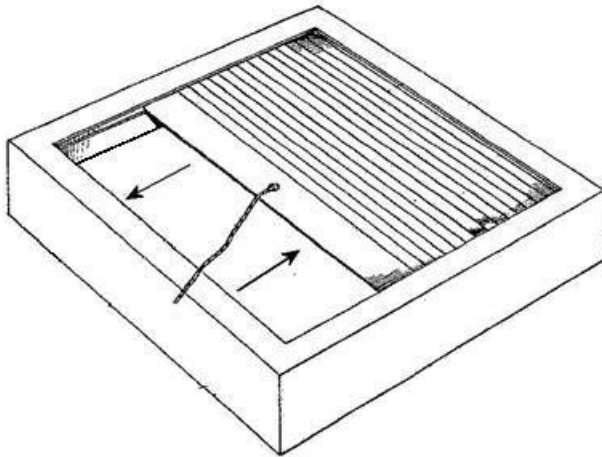
**References****Limiting references**

This place does not cover:

Sliding elements for covering and uncovering discharge openings of containers	B65D 5/723
Container lids removed by sliding	B65D 43/12
Linearly slidable, non-removable lids	B65D 43/20

Informative references

Attention is drawn to the following places, which may be of interest for search:

Drawer-and-shell type containers	B65D 5/38
Contents-dispensing means for drawer-and-shell-type containers	B65D 5/728

B65D 5/66

Hinged lids ({[B65D 5/325](#)} takes precedence)

References**Limiting references**

This place does not cover:

Whereby one blank forms three sides of the body, and the other blank forms the remaining sides, a hinged lid, and the opposite end closure	B65D 5/325
Combined with lines of weakness	B65D 5/54
For cigarette packs	B65D 85/10

B65D 5/6602

{formed by folding one or more extensions hinged to the upper edge of a tubular container body}

References**Informative references**

Attention is drawn to the following places, which may be of interest for search:

With end closures formed by inward folding of flaps and securing means of them by means of a tongue integral with one of the flaps	B65D 5/0254
Containers formed by erecting a rigid or semi-rigid blank having a cap-like lid hinged to an edge	B65D 85/1045

B65D 5/6605

{the lid being formed by two mating halves joined to opposite edges of the container body}

Definition statement

This place covers:

Illustrative example of subject matter classified in this group:

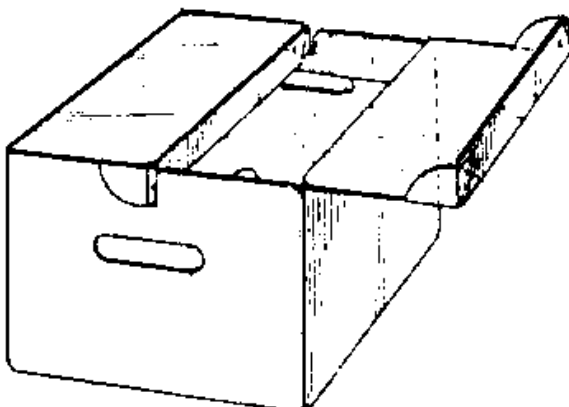

B65D 5/6608

{the lid being held in closed position by self-locking integral flaps}

Definition statement

This place covers:

Illustrative example of subject matter classified in this group:

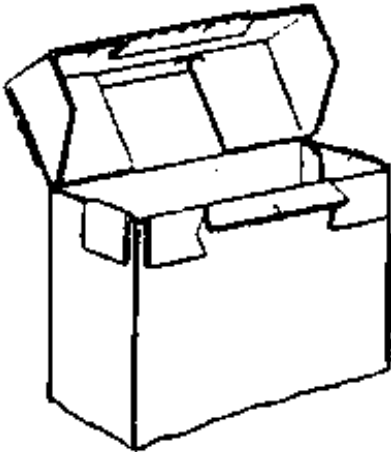

B65D 5/6611

{the lid being held in closed position by application of separate elements, e.g. clips, hooks, elastics}

Definition statement

This place covers:

Illustrative example of subject matter classified in this group:

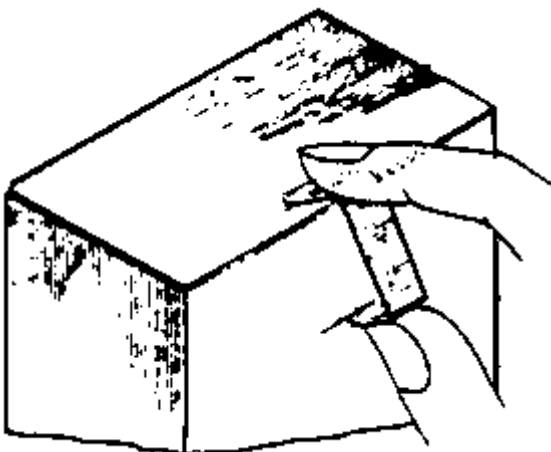

References

Informative references

Attention is drawn to the following places, which may be of interest for search:

Adhesive tapes, labels or the like	B65D 5/0236
Releasable fastenings clips	F16B 2/20

B65D 5/6614

{with means for retaining the lid in open position}

Definition statement

This place covers:

Illustrative example of subject matter classified in this group:

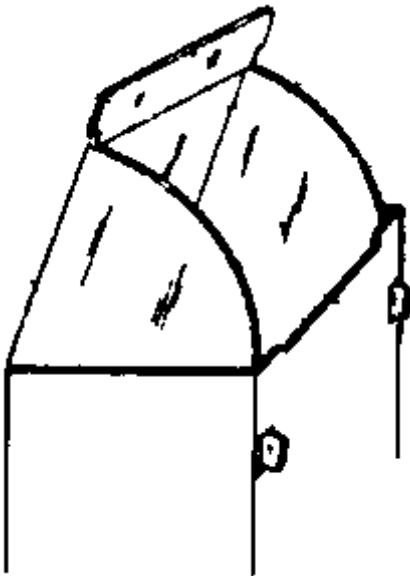

B65D 5/6617

{the container body sliding in an outer sleeve ([B65D 85/1054](#) takes precedence)}

References

Limiting references

This place does not cover:

Containers formed by erecting a rigid or semi-rigid blank, having a cap-like lid hinges to an edge combined with an outer sleeve connected to the lid	B65D 85/1054
---	------------------------------

Informative references

Attention is drawn to the following places, which may be of interest for search:

The container body sliding in an outer sleeve	B65D 5/6688
Contents dispensing means for drawer-and-shell-type containers	B65D 5/728

B65D 5/662

{the container being provided with an internal frame or the like for maintaining the lid in the closed position by friction}

Definition statement

This place covers:

Illustrative example of subject matter classified in this group:

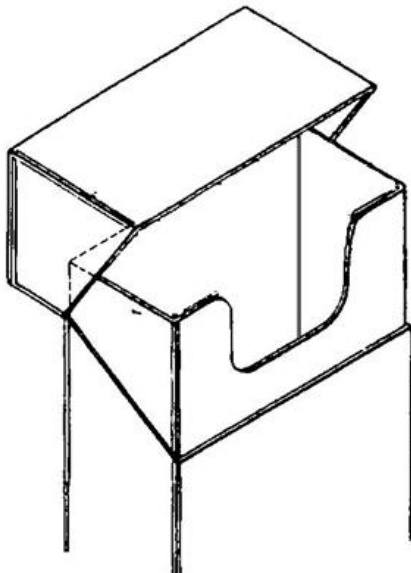
**References****Informative references**

Attention is drawn to the following places, which may be of interest for search:

For opening containers formed by erecting a blank in tubular form the lines of weakness being provided in the container body and defining after rupture a lid hinged to the upper edge of the container body the container being provided with an internal frame or the like for maintaining the lid in the closed position by friction	B65D 5/543
For opening containers formed by erecting a "cross-like" blank the container being provided with an internal frame or the like for maintaining the lid in the closed position by friction	B65D 5/5465
For opening containers formed by erecting a blank to U-shape the container being provided with an internal frame or the like for maintaining the lid in the closed position by friction	B65D 5/5485

Formed by folding extensions of a side panel of a container body formed by erecting a "cross-like" blank the container being provided with an internal frame or the like for maintaining the lid in the closed position by friction	B65D 5/6679
Formed by extensions hinged to the upper edge of a container body formed by erecting a blank to U-shape the container being provided with an internal frame or the like for maintaining the lid in the closed position by friction	B65D 5/6691

B65D 5/6623

{the lid being hinged about a line located in the top surface of the container}

Definition statement

This place covers:

Illustrative example of subject matter classified in this group:

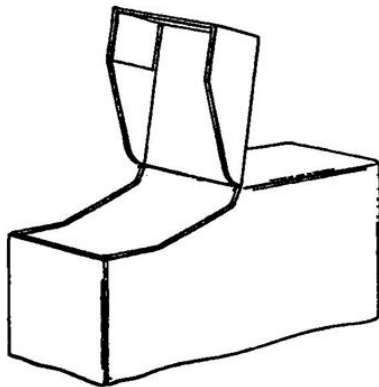

References

Informative references

Attention is drawn to the following places, which may be of interest for search:

For opening containers formed by erecting a blank in tubular form the lines of weakness being provided in the container body and defining after rupture a lid hinged about a line located in the top surface of the container	B65D 5/544
For opening containers formed by erecting a "cross-like" blank and defining after rupture a lid hinged about a line located in the top surface of the container	B65D 5/547
For opening containers formed by erecting a blank to U-shape and defining after rupture a lid hinged about a line located in the top surface of the container	B65D 5/549
Formed by folding extensions of a side panel of a container body formed by erecting a "cross-like" blank the lid being hinged about a line located in the top surface of the container	B65D 5/6682
Formed by extensions hinged to the upper edge of a container body formed by erecting a blank to U-shape the lid being hinged about a line located in the top surface of the container	B65D 5/6694

B65D 5/6629

{the lid being formed by two mating halves joined to opposite edges of the container body}

Definition statement

This place covers:

Illustrative example of subject matter classified in this group:

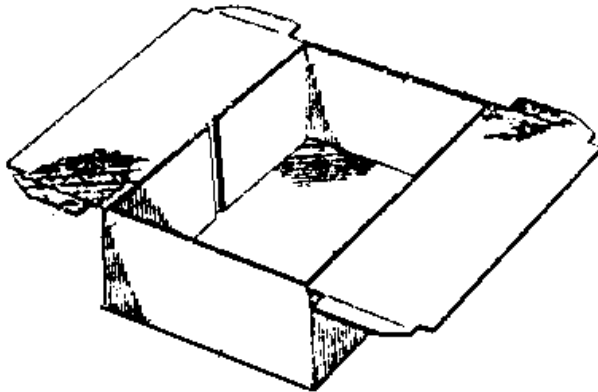

B65D 5/6632

{the lid-halves being held in closed position by flaps or tabs provided at their side edges only ([B65D 5/6644](#), [B65D 5/6647](#) take precedence)}

Definition statement

This place covers:

Illustrative example of subject matter classified in this group:

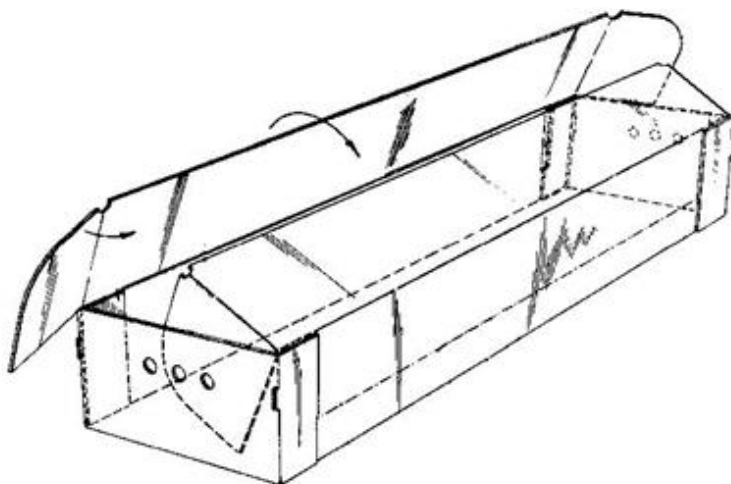

References

Limiting references

This place does not cover:

The lid-halves being held in closed position by local tabs or projections at the upper edge of opposite walls of the container body, e.g. by entering within slots provided in the lid-halves	B65D 5/6644
The lid-halves being held in closed position by application of separate elements, e.g. clips, hooks, cords	B65D 5/6647

B65D 5/6635

{the lid-halves being held in closed position by flaps or tabs provided at their edge opposite to their hinge ([B65D 5/6644](#), [B65D 5/6647](#) take precedence)}

Definition statement

This place covers:

Illustrative example of subject matter classified in this group:

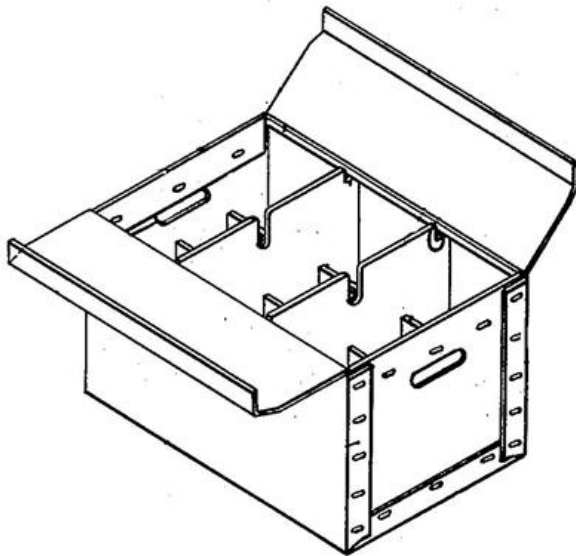

References

Limiting references

This place does not cover:

The lid-halves being held in closed position by local tabs or projections at the upper edge of opposite walls of the container body, e.g. by entering within slots provided in the lid-halves	B65D 5/6644
The lid-halves being held in closed position by application of separate elements, e.g. clips, hooks, cords	B65D 5/6647

B65D 5/6638

{combined with flaps or tabs provided at the side edges of the lid-halves}

Definition statement

This place covers:

Illustrative example of subject matter classified in this group:

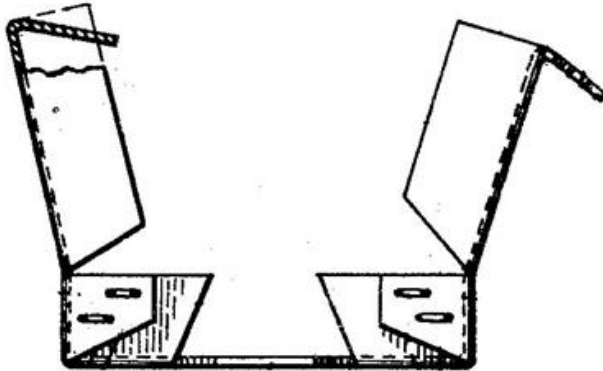

B65D 5/6641

{and connected to one another in order to form an uninterrupted flange}

Definition statement

This place covers:

Illustrative example of subject matter classified in this group:

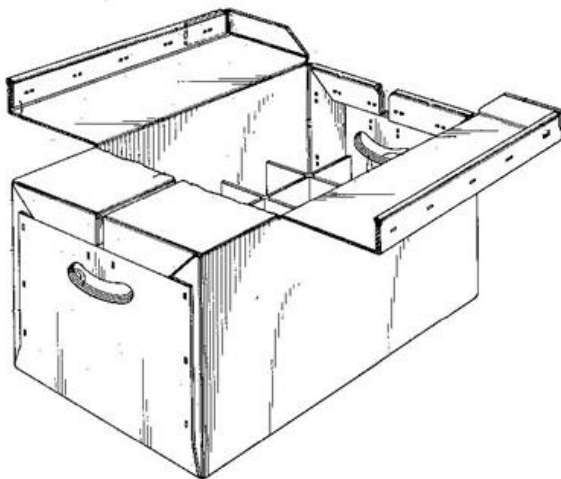

B65D 5/6644

{the lid-halves being held in closed position by local tabs or projections at the upper edge of opposite walls of the container body, e.g. by entering within slots provided in the lid-halves}

Definition statement

This place covers:

Illustrative example of subject matter classified in this group:

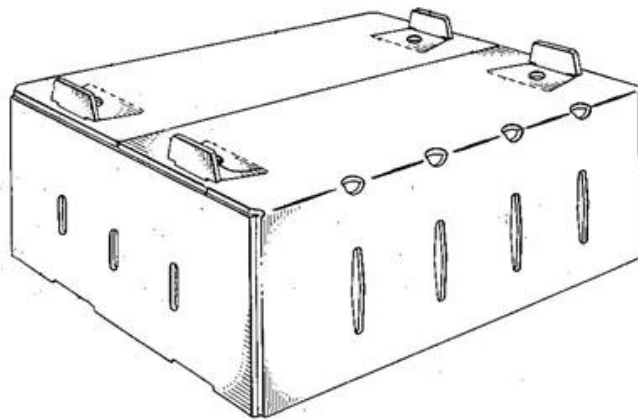

B65D 5/6647

{the lid-halves being held in closed position by application of separate elements, e.g. clips, hooks, cords}

Definition statement

This place covers:

Illustrative example of subject matter classified in this group:

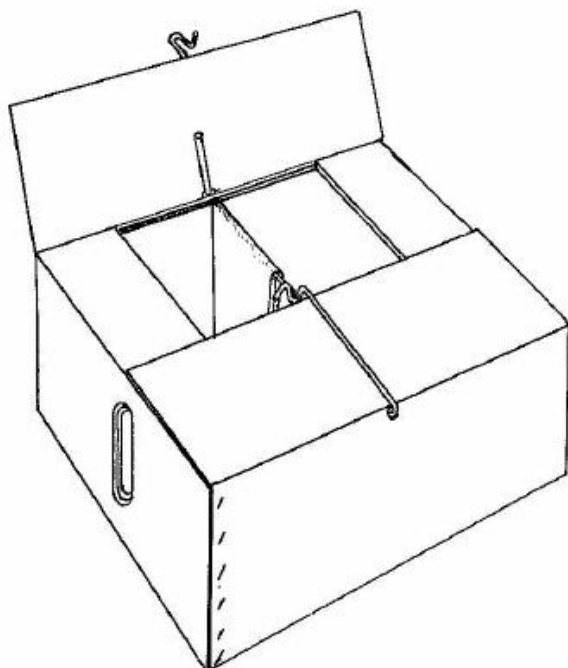

References

Informative references

Attention is drawn to the following places, which may be of interest for search:

The lid being held in closed position by application of separate elements, e.g. clips, hooks, cords	B65D 5/6673
---	-----------------------------

B65D 5/665

{the lid being held in closed position by self-locking integral flaps or tabs}

Definition statement

This place covers:

Illustrative example of subject matter classified in this group:

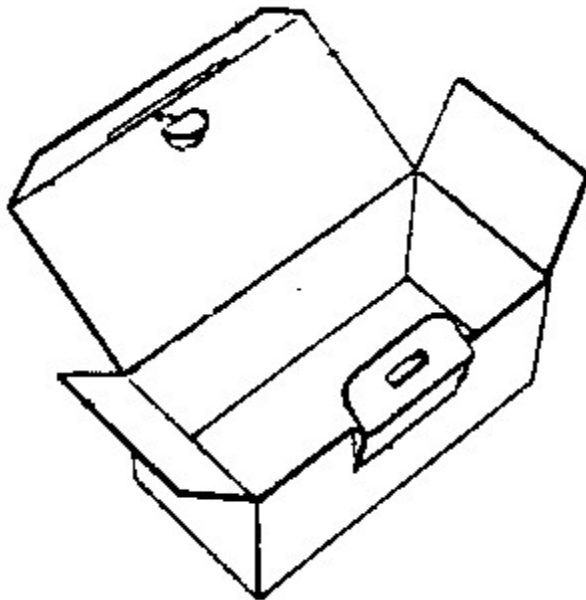

B65D 5/6652

{Flaps or tabs provided at the side edges of the lid only}

Definition statement

This place covers:

Illustrative example of subject matter classified in this group:

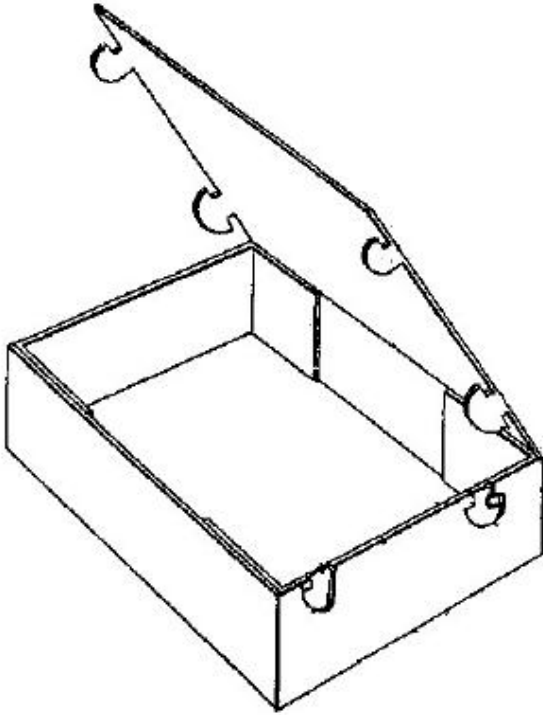

B65D 5/6655

{Local flaps or tabs provided at the lid edge opposite to the hinge}

Definition statement

This place covers:

Illustrative example of subject matter classified in this group:

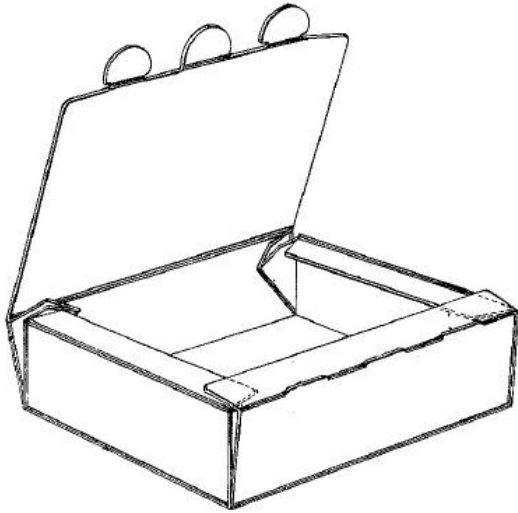

B65D 5/6658

{combined with flaps or tabs provided at the side edges of the lid}

Definition statement

This place covers:

Illustrative example of subject matter classified in this group:

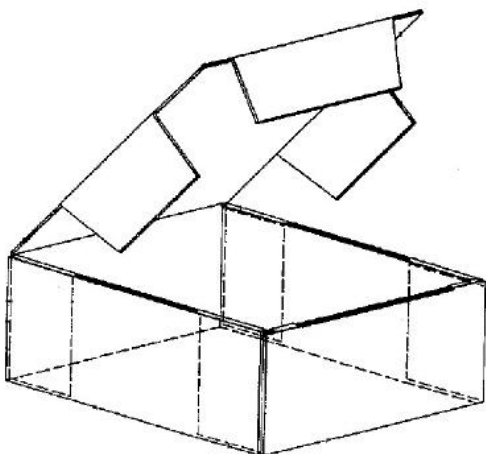

B65D 5/6661

{Flaps provided over the total length of the lid edge opposite to the hinge}

Definition statement

This place covers:

Illustrative example of subject matter classified in this group:

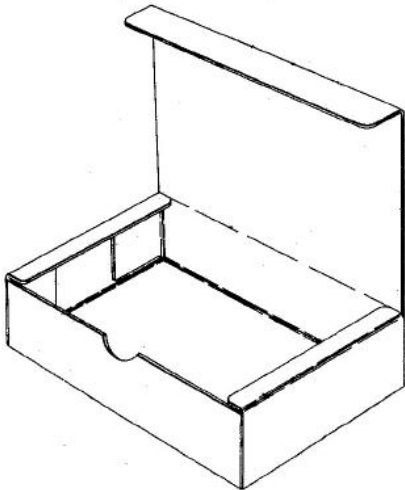

B65D 5/6664

{combined with flaps or tabs provided at the side edges of the lid}

Definition statement

This place covers:

Illustrative example of subject matter classified in this group:

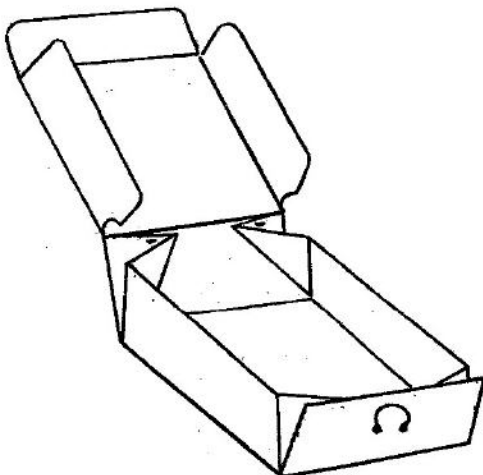

B65D 5/6667

{and connected to one another in order to form an uninterrupted telescoping flange ([B65D 5/667](#) takes precedence)}

Definition statement

This place covers:

Illustrative example of subject matter classified in this group:

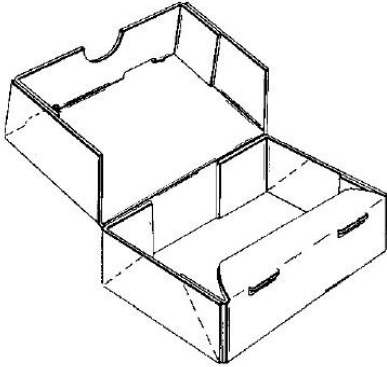
**References****Limiting references**

This place does not cover:

Lids in the form of an inverted tray	B65D 5/667
--------------------------------------	----------------------------

B65D 5/667

{Lids in the form of an inverted tray}

Definition statement

This place covers:

Illustrative example of subject matter classified in this group:

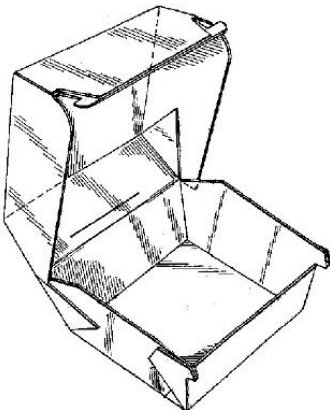

B65D 5/6673

{the lid being held in closed position by application of separate elements, e.g. clips, hooks, cords ([B65D 5/6647](#) takes precedence)}

Definition statement

This place covers:

Illustrative example of subject matter classified in this group:

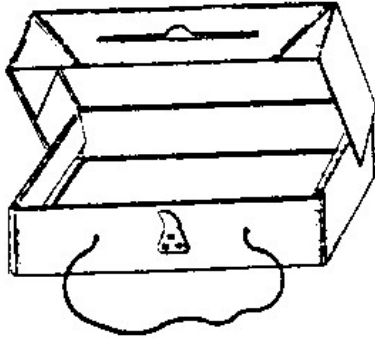
**References****Limiting references**

This place does not cover:

The lid-halves being held in closed position by application of separate elements, e.g. clips, hooks, cords	B65D 5/6647
Releasable fastenings clips	F16B 2/20

B65D 5/6676

{with means for retaining the lid in open position}

Definition statement

This place covers:

Illustrative example of subject matter classified in this group:

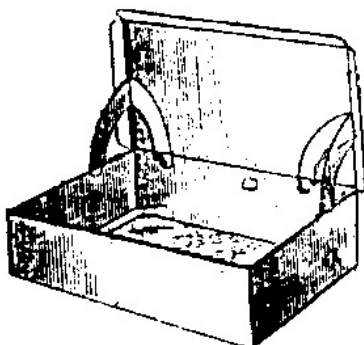

B65D 5/6679

{the container being provided with an internal frame or the like for maintaining the lid in the closed position by friction}

Definition statement

This place covers:

Illustrative example of subject matter classified in this group:

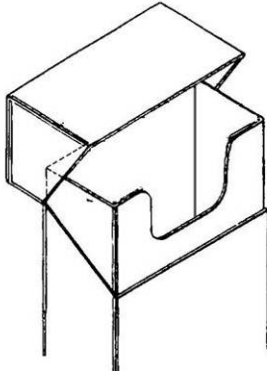
**References****Informative references**

Attention is drawn to the following places, which may be of interest for search:

The lines of weakness being provided in the container body, defining after rupture a lid hinged to the upper edge of the container body, the container being provided with an internal frame or the like for maintaining the lid in the closed position by friction	B65D 5/543
For opening containers formed by erecting a "cross-like" blank, the container being provided with an internal frame or the like for maintaining the lid in the closed position by friction	B65D 5/5465
For opening containers formed by erecting a blank to U-shape, the container being provided with an internal frame or the like for maintaining the lid in the closed position by friction	B65D 5/5485
Formed by folding one or more extensions hinged to the upper edge of a tubular container body, the container being provided with an internal frame or the like for maintaining the lid in the closed position by friction	B65D 5/662
Formed by extensions hinged to the upper edge of a container body formed by erecting a blank to U-shape, the container being provided with an internal frame or the like for maintaining the lid in the closed position by friction	B65D 5/6691

B65D 5/6682

{the lid being hinged about a line located in the top surface of the container}

Definition statement

This place covers:

Illustrative example of subject matter classified in this group:

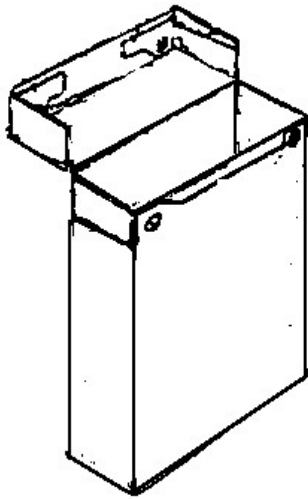
**References****Informative references**

Attention is drawn to the following places, which may be of interest for search:

For opening containers formed by erecting a blank in tubular form, the lines of weakness being provided in the container body, and defining after rupture a lid hinged about a line located in the top surface of the container	B65D 5/544
For opening containers formed by erecting a "cross-like" blank and defining after rupture a lid hinged about a line located in the top surface of the container	B65D 5/547
For opening containers formed by erecting a blank to U-shape and defining after rupture a lid hinged about a line located in the top surface of the container	B65D 5/549
Formed by folding one or more extensions hinged to the upper edge of a tubular container body, the lid being hinged about a line located in the top surface of the container	B65D 5/6623
Formed by extensions hinged to the upper edge of a container body formed by erecting a blank to U-shape, the lid being hinged about a line located in the top surface of the container	B65D 5/6694

B65D 5/6685

{formed by extensions hinged to the upper edge of a container body formed by erecting a blank to U-shape}

References**Informative references**

Attention is drawn to the following places, which may be of interest for search:

Containers formed by erecting a rigid or semi-rigid blank	B65D 85/1036
---	------------------------------

B65D 5/6688

{the container body sliding in an outer sleeve ([B65D 85/1054](#) takes precedence)}

Definition statement

This place covers:

Illustrative example of subject matter classified in this group:

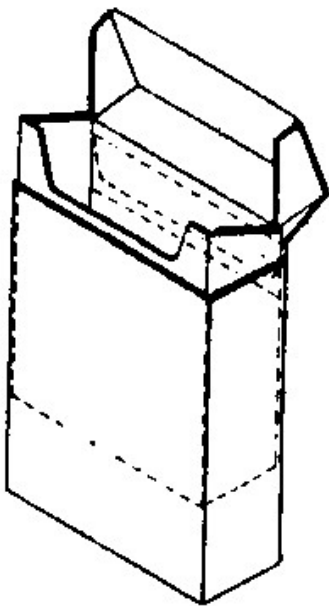
**References****Limiting references**

This place does not cover:

Containers formed by erecting a rigid or semi-rigid blank having a cap-like lid hinged to an edge combined with an outer sleeve connected to the lid	B65D 85/1054
--	------------------------------

B65D 5/6691

{the container being provided with an internal frame or the like for maintaining the lid in the closed position by friction}

Definition statement

This place covers:

Illustrative example of subject matter classified in this group:

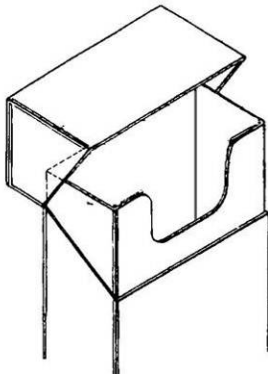
**References****Informative references**

Attention is drawn to the following places, which may be of interest for search:

The lines of weakness being provided in the container body, defining after rupture a lid hinged to the upper edge of the container body, the container being provided with an internal frame or the like for maintaining the lid in the closed position by friction	B65D 5/543
For opening containers formed by erecting a "cross-like" blank, the container being provided with an internal frame or the like for maintaining the lid in the closed position by friction	B65D 5/5465
For opening containers formed by erecting a blank to U-shape, the container being provided with an internal frame or the like for maintaining the lid in the closed position by friction	B65D 5/5485
Formed by folding one or more extensions hinged to the upper edge of a tubular container body, the container being provided with an internal frame or the like for maintaining the lid in the closed position by friction	B65D 5/662
Formed by folding extensions of a side panel of a container body formed by erecting a "cross-like" blank, the container being provided with an internal frame or the like for maintaining the lid in the closed position by friction	B65D 5/6679

B65D 5/6694

{the lid being hinged about a line located in the top surface of the container}

Definition statement

This place covers:

Illustrative example of subject matter classified in this group:

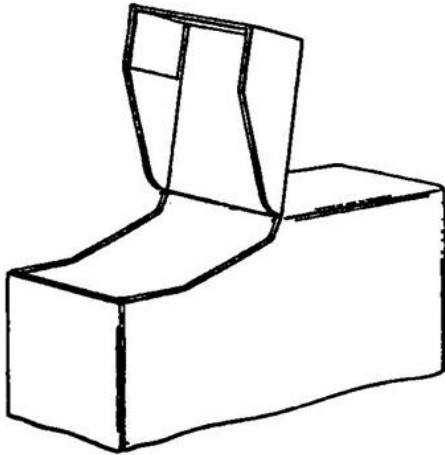
**References****Informative references**

Attention is drawn to the following places, which may be of interest for search:

For opening containers formed by erecting a blank in tubular form, the lines of weakness being provided in the container body, and defining after rupture a lid hinged about a line located in the top surface of the container	B65D 5/544
For opening containers formed by erecting a "cross-like" blank and defining after rupture a lid hinged about a line located in the top surface of the container	B65D 5/547
For opening containers formed by erecting a blank to U-shape and defining after rupture a lid hinged about a line located in the top surface of the container	B65D 5/549
Formed by folding one or more extensions hinged to the upper edge of a tubular container body, the lid being hinged about a line located in the top surface of the container	B65D 5/6623
Formed by folding extensions of a side panel of a container body formed by erecting a "cross-like" blank, the lid being hinged about a line located in the top surface of the container	B65D 5/6682

B65D 5/6697

{Separate lids attached to the container body by a hinge element}

Definition statement

This place covers:

Illustrative example of subject matter classified in this group:

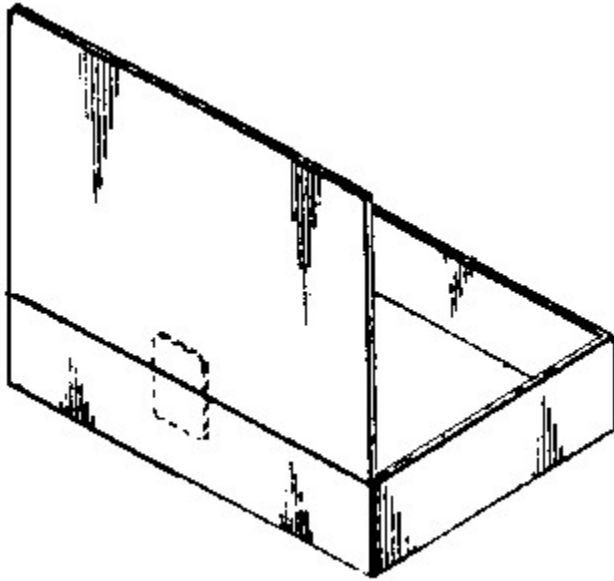

B65D 5/68

Telescope flanged lids

Definition statement

This place covers:

Illustrative example of subject matter classified in this group:

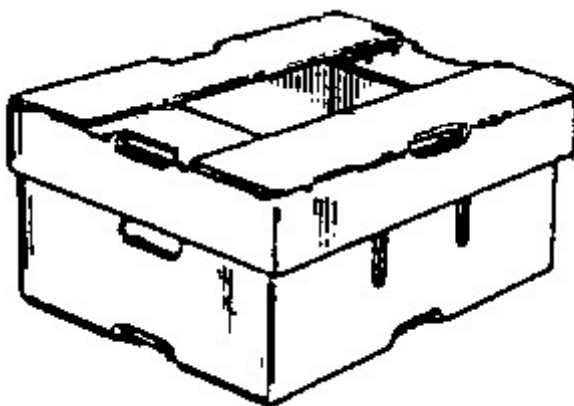

B65D 5/685

{having an inwardly or upwardly extending tab on the lid side wall cooperating with a tab on, or an opening in, the container side wall}

Definition statement

This place covers:

Illustrative example of subject matter classified in this group:

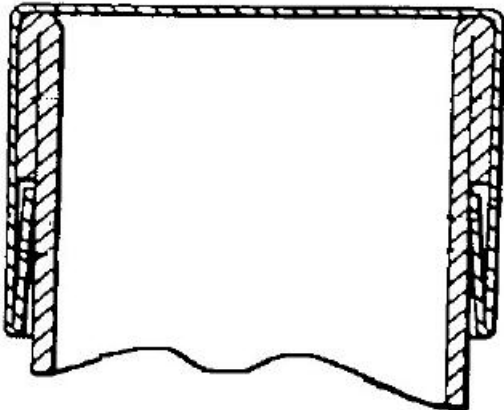
**B65D 5/70**

Break-in flaps, or members adapted to be torn-off, to provide pouring openings
([B65D 5/74](#) takes precedence)

References**Limiting references**

This place does not cover:

Spouts	B65D 5/74
--------	---------------------------

B65D 5/701

{Tearable flaps defined by score-lines or incisions provided in the closure flaps of a tubular container made of a single blank}

Definition statement

This place covers:

Illustrative example of subject matter classified in this group:

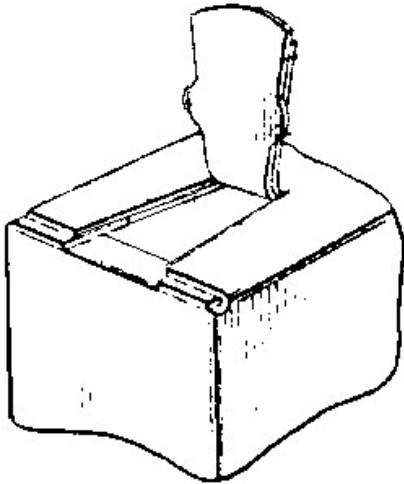

B65D 5/703

{the score-lines or incisions extending in the body of the tubular container}

Definition statement

This place covers:

Illustrative example of subject matter classified in this group:

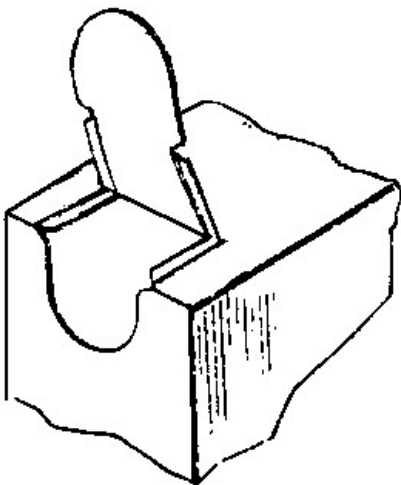

B65D 5/705

{Tearable flaps defined by score-lines or incisions provided in the body of a tubular container made of a single blank}

Definition statement

This place covers:

Illustrative example of subject matter classified in this group:

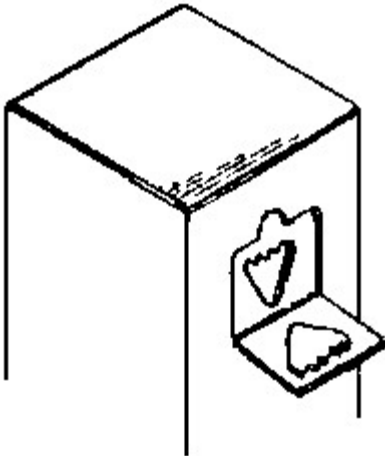

References

Informative references

Attention is drawn to the following places, which may be of interest for search:

Spouts formed by deforming or tearing scored or incised parts of the side-wall of containers	B65D 5/743
--	----------------------------

B65D 5/706

{Tearable flaps defined by score-lines or incisions provided in a separate end closure of a tubular container}

Definition statement

This place covers:

Illustrative example of subject matter classified in this group:

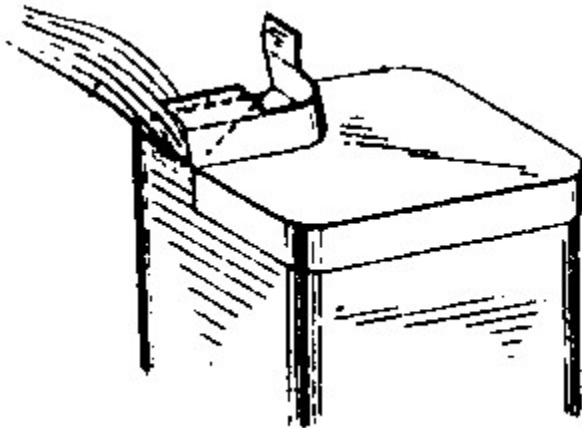

B65D 5/708

{Separate tearable flexible elements covering a discharge opening of a container, e.g. adhesive tape}

Definition statement

This place covers:

Illustrative example of subject matter classified in this group:

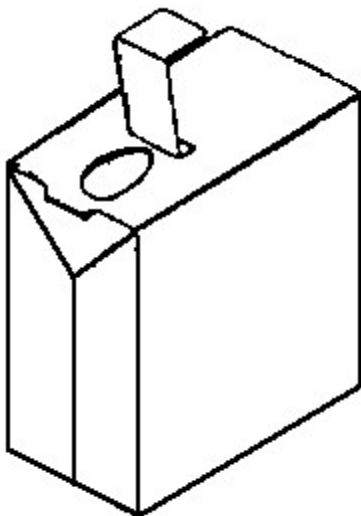

References

Informative references

Attention is drawn to the following places, which may be of interest for search:

Non-integral frangible members applied to, or inserted in, a preformed opening, e.g. tearable strips, plastic plugs	B65D 17/50
---	----------------------------

B65D 5/722

{having an alternating movement co-operating with incised or scored openings near the bottom-edges of the bodies of tubular containers}

Definition statement

This place covers:

Illustrative example of subject matter classified in this group:

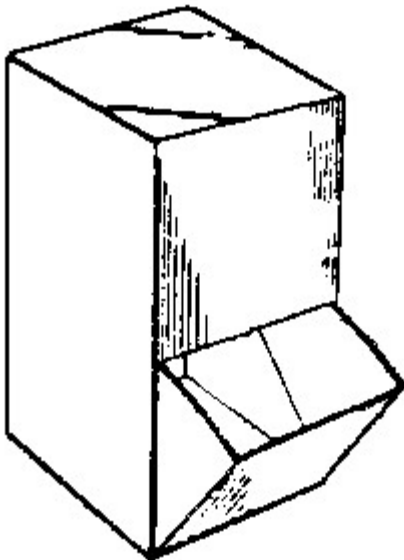

References

Informative references

Attention is drawn to the following places, which may be of interest for search:

Combined with swivelling devices having a bottom-wall and two side-walls	B65D 5/744
--	----------------------------

B65D 5/723

{Sliding elements for covering and uncovering discharge openings of containers, e.g. slide-closures}

Definition statement

This place covers:

Illustrative example of subject matter classified in this group:

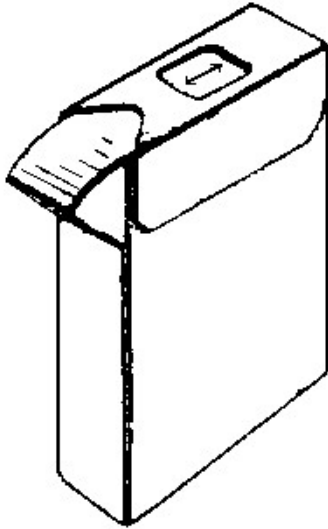

References

Informative references

Attention is drawn to the following places, which may be of interest for search:

Contents-dispensing means consisting of mobile elements forming part of the containers or attached to the containers	B65D 5/721
--	----------------------------

B65D 5/724

{Internal fittings facilitating the discharge of contents, e.g. guiding panels, movable bottoms or lifting strips}

Definition statement

This place covers:

Illustrative example of subject matter classified in this group:

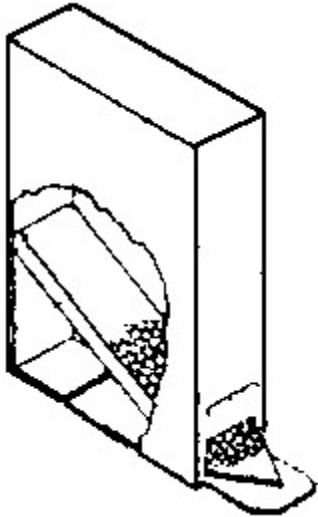

B65D 5/725

{Incised or pre-scored openings or windows provided in the side wall of containers}

Definition statement

This place covers:

Illustrative example of subject matter classified in this group:

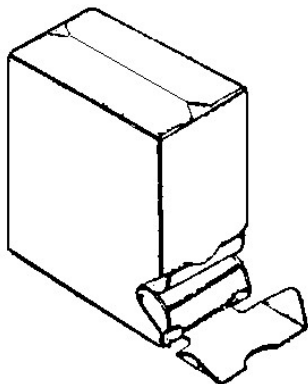

References

Informative references

Attention is drawn to the following places, which may be of interest for search:

The tubular body being formed with an aperture or removable portion arranged to allow removal or insertion of contents through one or more sides	B65D 5/16
--	---------------------------

B65D 5/726

{Means for discharging contents through the bottom of containers}

Definition statement

This place covers:

Illustrative example of subject matter classified in this group:

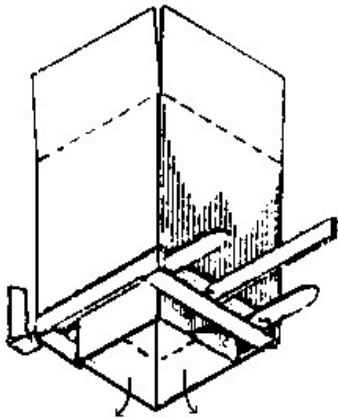

B65D 5/727

{Dispensing openings provided in the upper end-walls of tubular containers, the openings being closed by means of separate stopper or other closure elements}

Definition statement

This place covers:

Illustrative example of subject matter classified in this group:

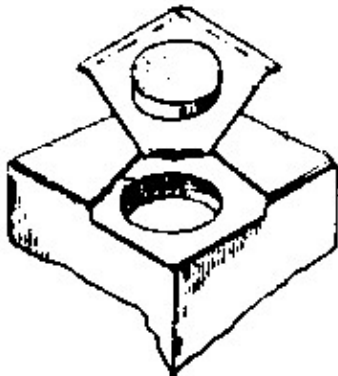

References

Informative references

Attention is drawn to the following places, which may be of interest for search:

Non-integral frangible members applied to, or inserted in, a preformed opening, e.g. tearable strips, plastic plugs	B65D 17/50
---	----------------------------

B65D 5/728**{for drawer-and-shell-type containers}****Definition statement***This place covers:*

Illustrative example of subject matter classified in this group:

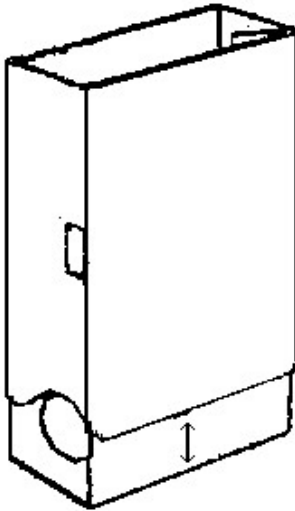
**References****Informative references***Attention is drawn to the following places, which may be of interest for search:*

Containers formed by erecting a rigid or semi-rigid blank having a cap-like lid hinged to an edge combined with an outer sleeve connected to the lid	B65D 85/1054
--	------------------------------

B65D 5/741**{for containers having a tubular body ([B65D 5/746](#) takes precedence)}****References****Limiting references***This place does not cover:*

Spouts formed separately from the container	B65D 5/746
---	----------------------------

B65D 5/742

{Spouts formed by deforming or tearing the closure flaps or severed or incised parts of the closure flaps ([B65D 5/06](#) takes precedence)}

Definition statement

This place covers:

Illustrative example of subject matter classified in this group:

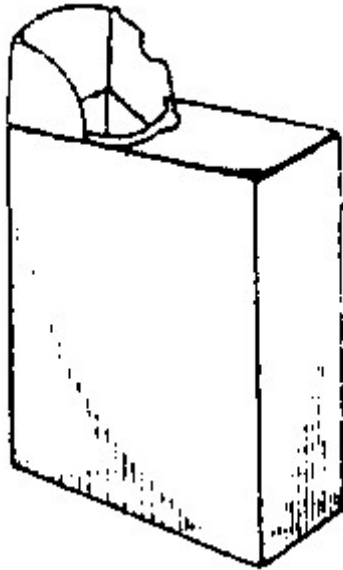
**References****Limiting references**

This place does not cover:

With end-closing or contents-supporting elements formed by folding inwardly a wall extending from, and continuously around, an end of the tubular body	B65D 5/06
--	---------------------------

B65D 5/743

{Spouts formed by deforming or tearing scored or incised parts of the side-wall of containers}

Definition statement

This place covers:

Illustrative example of subject matter classified in this group:

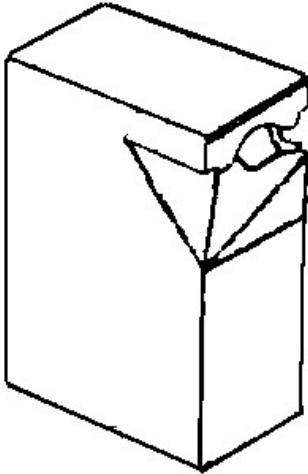

References

Informative references

Attention is drawn to the following places, which may be of interest for search:

Tearable flaps defined by score-lines or incisions provided in the body of a tubular container made of a single blank	B65D 5/705
---	----------------------------

B65D 5/744

{combined with swivelling devices having a bottom-wall and two side-walls}

Definition statement

This place covers:

Illustrative example of subject matter classified in this group:

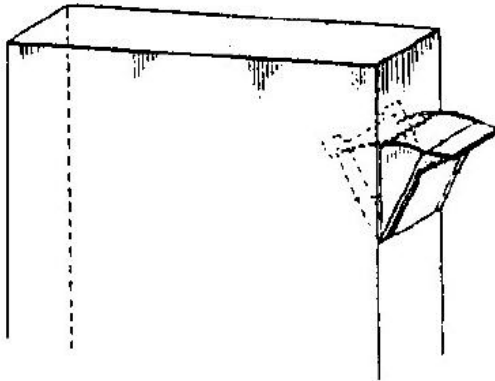
**References****Informative references**

Attention is drawn to the following places, which may be of interest for search:

Having an alternating movement co-operating with incised or scored openings near the bottom-edges of the bodies of tubular containers	B65D 5/722
Closures with swivelling dispensing devices	B65D 47/046

B65D 5/745

{Spouts formed by deforming or tearing parts of the upper wall, combined with a deformation of a part of the body of the container}

Definition statement

This place covers:

Illustrative example of subject matter classified in this group:

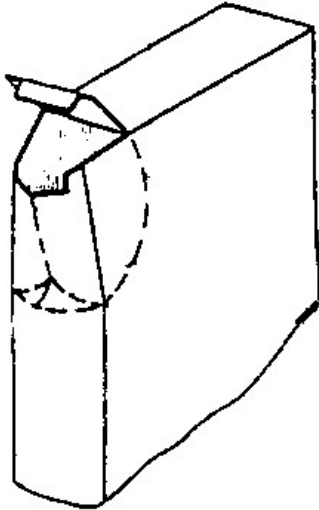

B65D 5/746

{Spouts formed separately from the container}

Definition statement

This place covers:

Illustrative example of subject matter classified in this group:

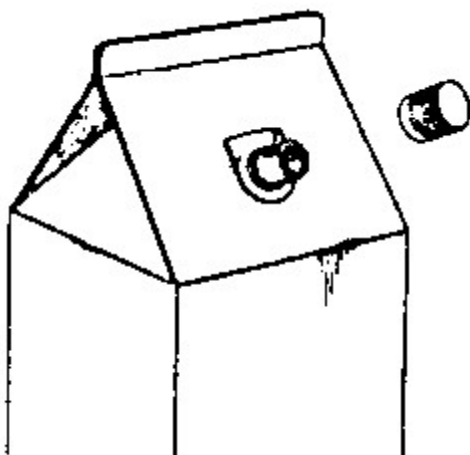

B65D 5/747

{with means for piercing or cutting the container wall or a membrane connected to said wall}

References**Informative references**

Attention is drawn to the following places, which may be of interest for search:

Caps, lids, or covers co-operating with an inner closure arranged to be opened by piercing, cutting, or tearing having means for piercing, cutting, or tearing the inner closure	B65D 51/22
--	----------------------------

B65D 5/748

{a major part of the container wall or membrane being left inside the container after the opening}

Definition statement

This place covers:

Illustrative example of subject matter classified in this group:

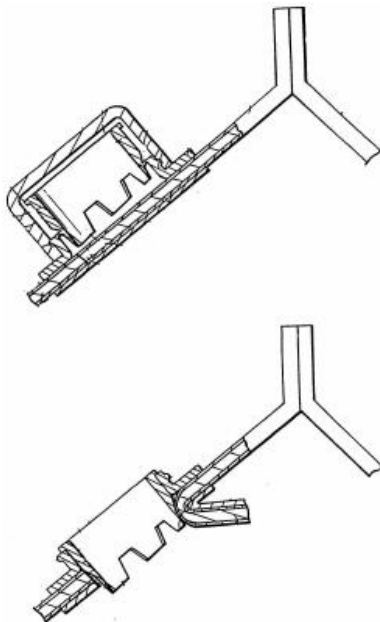
**References****Informative references**

Attention is drawn to the following places, which may be of interest for search:

A major part of the inner closure being left inside the container after the opening	B65D 51/221
---	-----------------------------

B65D 5/749

{a major part of the container wall or membrane being removed from the container after the opening}

Definition statement

This place covers:

Illustrative example of subject matter classified in this group:

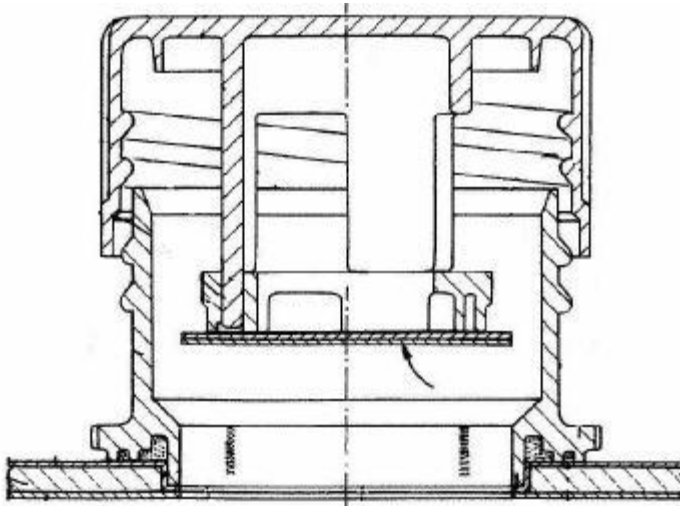
**References****Informative references**

Attention is drawn to the following places, which may be of interest for search:

A major part of the inner closure being removed from the container after the opening	B65D 51/228
--	-----------------------------

B65D 5/76

for discharging metered quantities

Definition statement

This place covers:

Illustrative example of subject matter classified in this group:

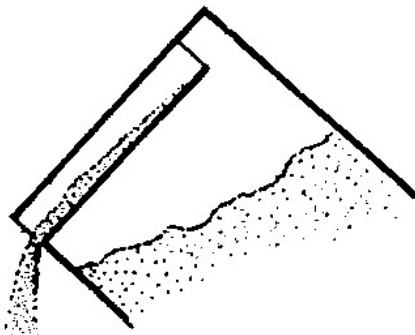

References

Informative references

Attention is drawn to the following places, which may be of interest for search:

Devices for discharging successive articles or portions of contents	B65D 25/52
---	----------------------------

B65D 7/00

{Containers having bodies formed by interconnecting or uniting two or more rigid, or substantially rigid, components made wholly or mainly of metal (specially constructed to be opened by cutting, piercing, or tearing of wall portions [B65D 17/00](#); pallets [B65D 19/00](#); tanks for domestic water storage heaters [F24H 1/181](#))}

References

Limiting references

This place does not cover:

Milk churns	A61J 9/00
-------------	---------------------------

B65D 7/02

{characterised by shape}

References

Limiting references

This place does not cover:

Milk churns	A61J 9/00
-------------	---------------------------

B65D 7/04

{of curved cross-section, e.g. cans of circular or elliptical cross-section (thermally insulated [B65D 81/3813](#), [B65D 81/3837](#))}

References

Limiting references

This place does not cover:

Milk churns	A61J 9/00
-------------	---------------------------

B65D 7/045

{Casks, barrels, or drums in their entirety, e.g. beer barrels, i.e. presenting most of the following features like rolling beads, double walls, reinforcing and supporting beads for end walls (thermally insulated barrels, [B65D 81/3802](#))}

Definition statement

This place covers:

Illustrative example of subject matter classified in this group:

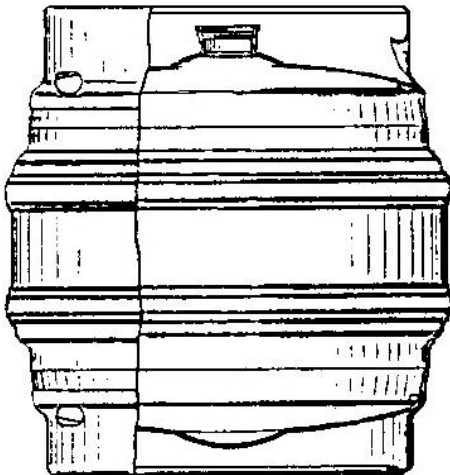

References

Limiting references

This place does not cover:

Filling or emptying apertures only	B65D 7/40
Milk churns	A61J 9/00

Informative references

Attention is drawn to the following places, which may be of interest for search:

Cans, casks, barrels, or drums characterised by location or arrangement of filling or discharge apertures	B65D 1/20
Arrangements of filling or discharging apertures	B65D 11/08

B65D 7/065

{with partitions or compartments}

Definition statement

This place covers:

Illustrative example of subject matter classified in this group:

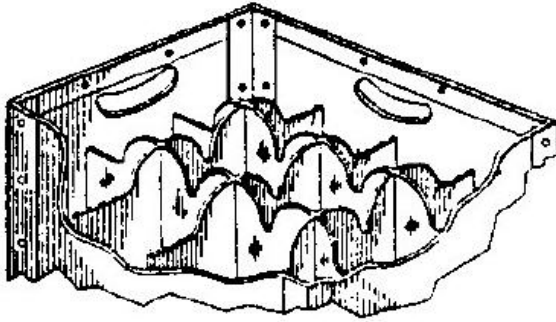

References

Informative references

Attention is drawn to the following places, which may be of interest for search:

Bottle crates not made in one piece	B65D 85/305
-------------------------------------	-----------------------------

B65D 7/20

{made of wire}

Definition statement

This place covers:

Illustrative example of subject matter classified in this group:

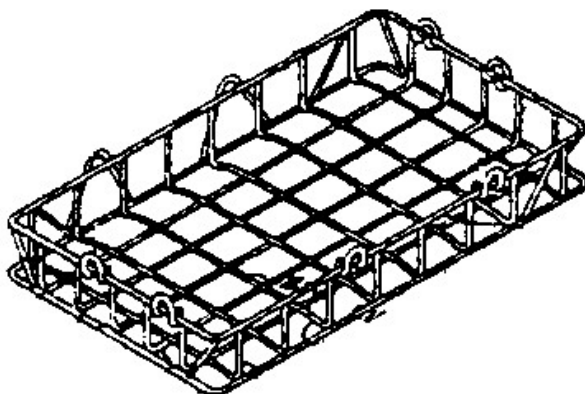

References

Limiting references

This place does not cover:

Collapsible	B65D 7/24
Containers specially shaped, or provided with fittings or attachments, to facilitate nesting, stacking, or joining together	B65D 21/02

B65D 7/26

{with all parts hinged together}

Definition statement

This place covers:

Illustrative example of subject matter classified in this group:

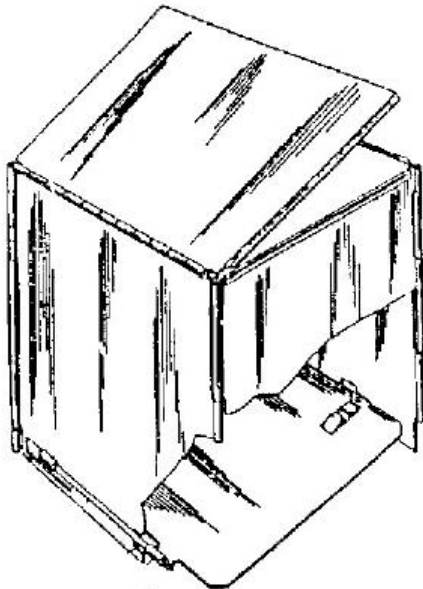

B65D 7/28

{with some parts detachable and other parts hinged together}

Definition statement

This place covers:

Illustrative example of subject matter classified in this group:

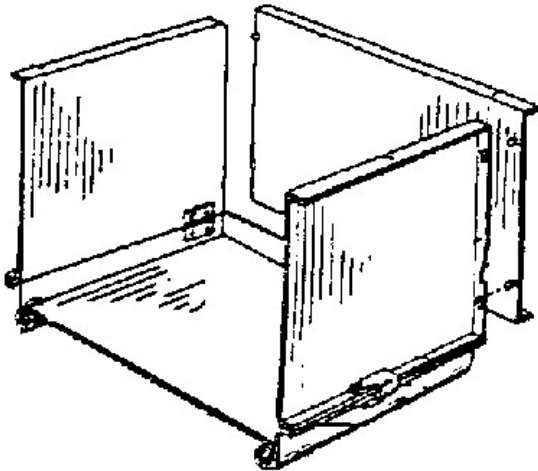

B65D 7/32

{separate from container walls}

Definition statement

This place covers:

Illustrative example of subject matter classified in this group:

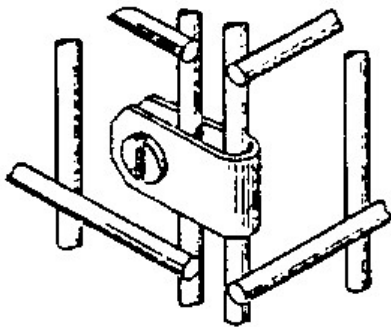

B65D 7/36**{formed by rolling, or by rolling and pressing}****Definition statement***This place covers:*

Illustrative example of subject matter classified in this group:

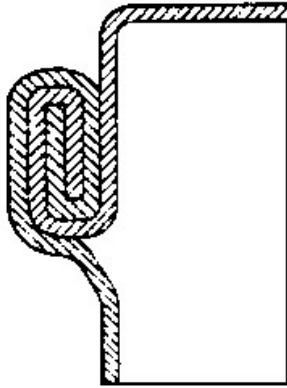
**References*****Informative references****Attention is drawn to the following places, which may be of interest for search:*

Closures secured by folding or rolling and pressing	B65D 17/08
Container closures formed after filling by applying separate lids or covers, the cover being maintained on the container by mechanical means	B65D 77/2004

B65D 7/38**{formed by soldering, welding, or otherwise uniting opposed surfaces}****Definition statement***This place covers:*

Illustrative example of subject matter classified in this group:

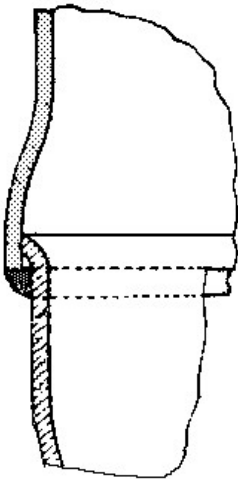
**References****Informative references***Attention is drawn to the following places, which may be of interest for search:*

Closures secured by soldering, welding, or otherwise uniting opposed surfaces	B65D 17/12
---	----------------------------

B65D 7/40**{with walls formed with filling or emptying apertures}****Definition statement***This place covers:*

Illustrative example of subject matter classified in this group:

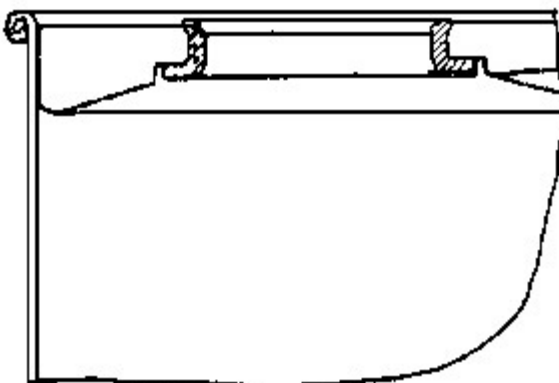

References

Limiting references

This place does not cover:

For plastic barrels	B65D 1/20 , B65D 11/08
---------------------	--

Informative references

Attention is drawn to the following places, which may be of interest for search:

Casks, barrels, or drums in their entirety, e.g. beer barrels	B65D 7/045
---	----------------------------

B65D 7/46

{Corrugations}

Definition statement

This place covers:

Illustrative example of subject matter classified in this group:

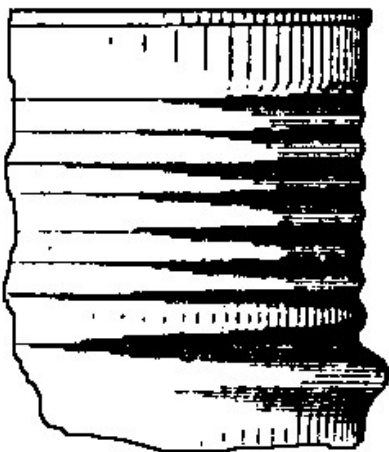

B65D 7/48

{Local reinforcements, e.g. adjacent closures}

References

Informative references

Attention is drawn to the following places, which may be of interest for search:

Lids secured to an intermediate ring or like annular member fixed to the container mouth	B65D 2543/00435
--	---------------------------------

B65D 9/04

{made up of staves, e.g. barrels for liquids (thermally insulated barrels, [B65D 81/3802](#))}

Definition statement

This place covers:

Illustrative example of subject matter classified in this group:

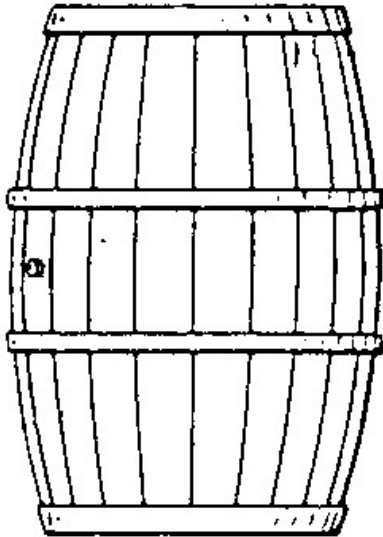
**B65D 9/06**

{Boxes or crates of polygonal cross-section}

References**Limiting references**

This place does not cover:

Bottle crates made in one piece	B65D 1/243
Baskets or like containers made in interwoven or intermeshing flexible wooden material or by attaching thin wooden strips to a supporting framework	B65D 9/10
Bottle crates not made in one piece	B65D 85/305

B65D 9/10

{Baskets or like containers made in interwoven or intermeshing flexible wooden material or by attaching thin wooden strips to a supporting framework}

Definition statement

This place covers:

Illustrative example of subject matter classified in this group:

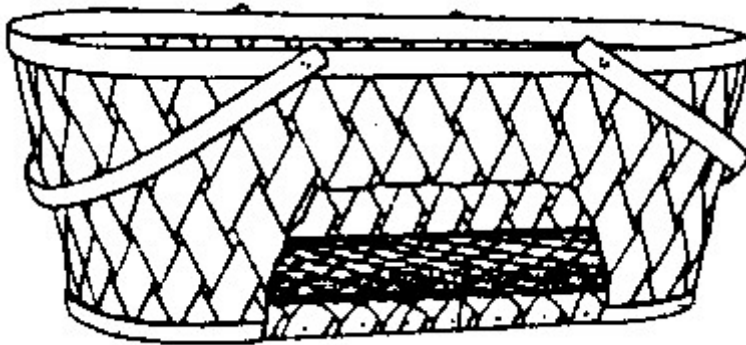

B65D 9/14

{with all parts hinged together}

Definition statement

This place covers:

Illustrative example of subject matter classified in this group:

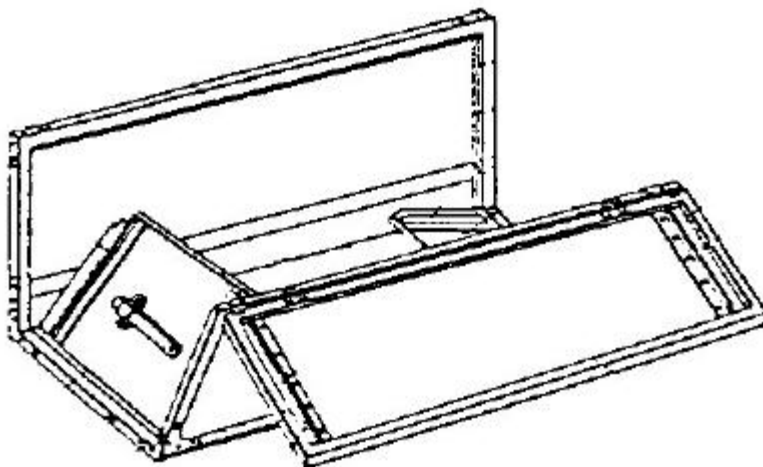

B65D 9/16

{wire-bound boxes}

Definition statement

This place covers:

Illustrative example of subject matter classified in this group:

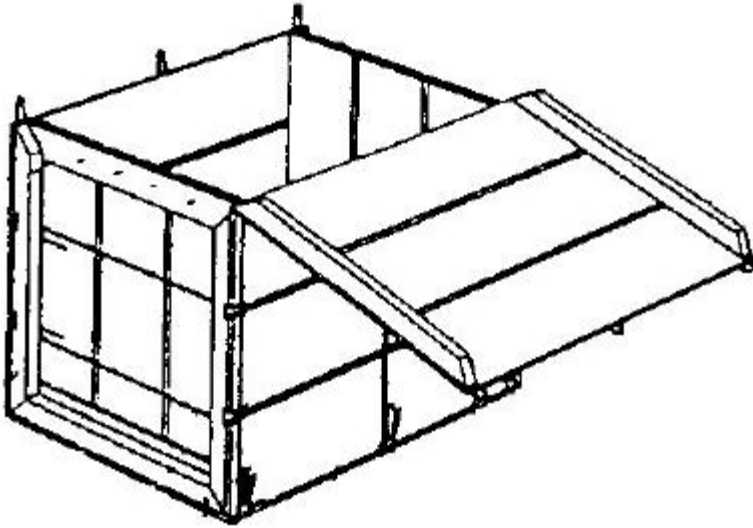

B65D 9/18

{with some parts detachable and other parts hinged together}

Definition statement

This place covers:

Illustrative example of subject matter classified in this group:

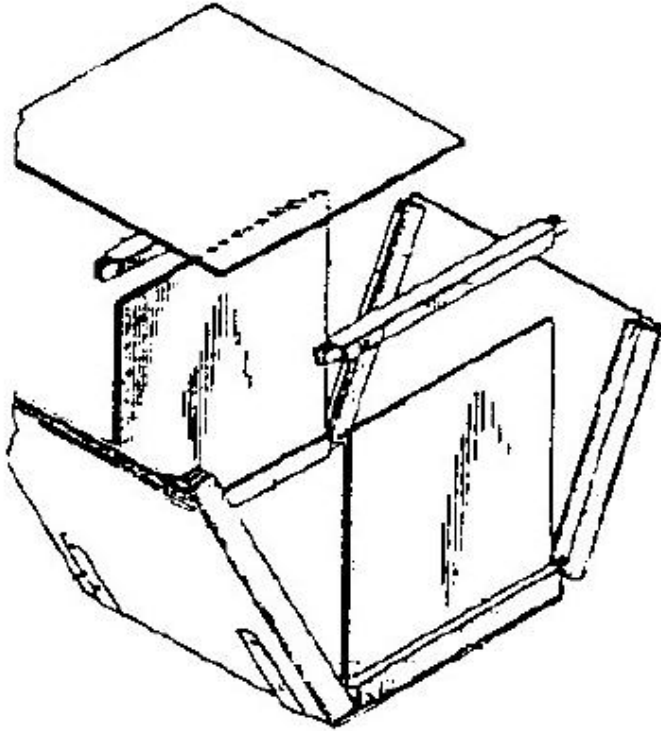

B65D 9/20

{wire-bound boxes}

Definition statement

This place covers:

Illustrative example of subject matter classified in this group:

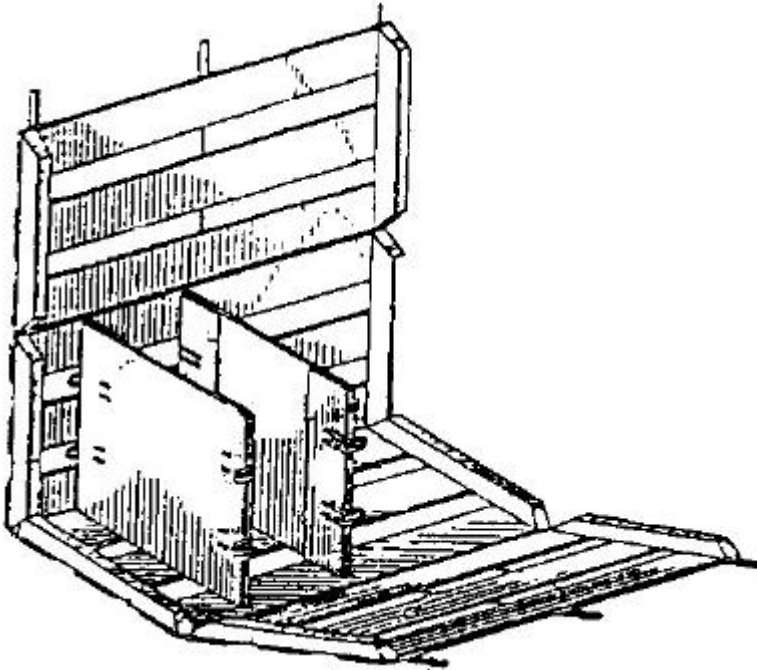

B65D 9/24

{separate from container walls}

Definition statement

This place covers:

Illustrative example of subject matter classified in this group:

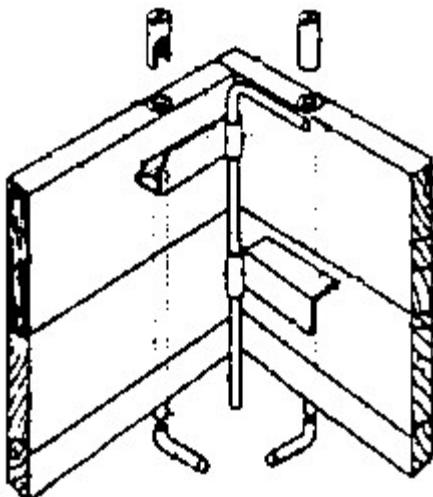

B65D 9/28**{with bottoms movable under influence of contents}****References****Limiting references***This place does not cover:*

Containers or packages provided with a piston or with a movable bottom or partition having approximately the same section as the container, moved by a spring-like mechanism	B65D 83/0038
Containers or packages provided with a piston or with a movable bottom or partition having approximately the same section as the container, the piston or movable bottom being pulled upwards to dispense the contents	B65D 83/005

Informative references*Attention is drawn to the following places, which may be of interest for search:*

Containers of variable capacity	B65D 21/08
---------------------------------	----------------------------

B65D 9/30**{Applications of laminates as wall material, e.g. plywood}****Definition statement***This place covers:*

Illustrative example of subject matter classified in this group:

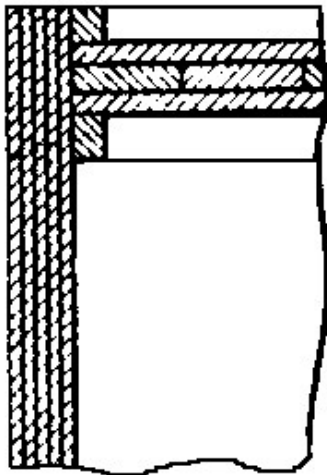

B65D 9/34

{Joints; Local reinforcements}

Definition statement

This place covers:

Illustrative example of subject matter classified in this group:

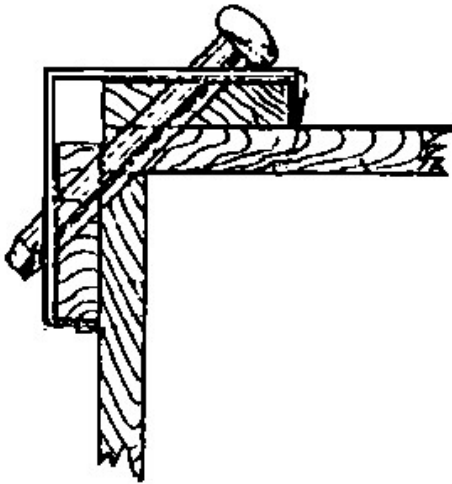

B65D 9/38

{Metal bands or strips}

Definition statement

This place covers:

Illustrative example of subject matter classified in this group:

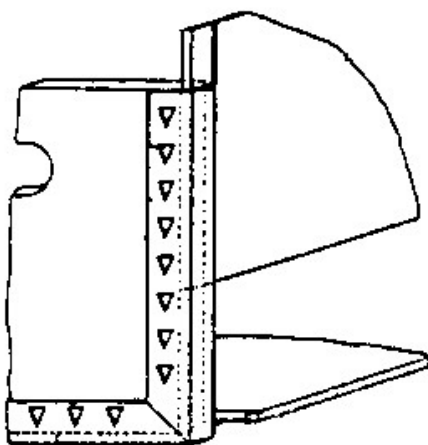

B65D 11/04

{Bottles or similar containers with necks or like restricted apertures designed for pouring contents (thermally insulated [B65D 81/3837](#))}

Definition statement

This place covers:

Illustrative example of subject matter classified in this group:

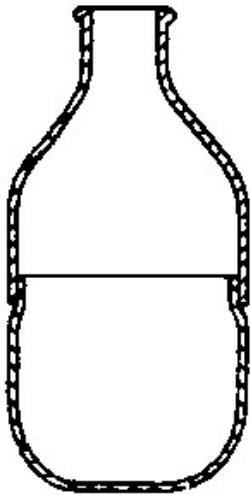

B65D 11/06

{Drums or barrels (thermally insulated [B65D 81/3802](#))}

Definition statement

This place covers:

Illustrative example of subject matter classified in this group:

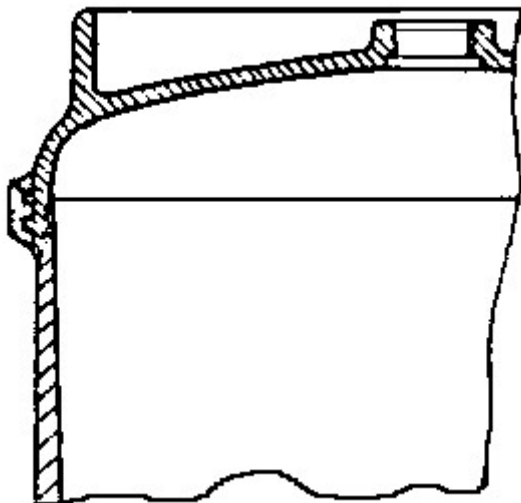

B65D 11/08**{Arrangements of filling or discharging apertures}****Definition statement***This place covers:*

Illustrative example of subject matter classified in this group:

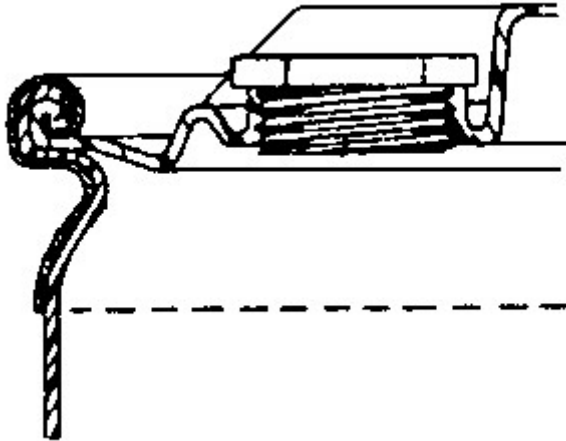
**References****Limiting references***This place does not cover:*

For one piece plastic drums	B65D 1/20
For metal drums	B65D 7/40

B65D 11/10**{of polygonal cross-section and all parts being permanently connected to each other ([B65D 11/18](#) takes precedence)}****References****Limiting references***This place does not cover:*

Bottle crates	B65D 1/243 , B65D 85/305
Collapsible	B65D 11/18

B65D 11/105

{the container being formed by two mating U-shaped halves connected to each other after a rotation of 90 degrees}

Definition statement

This place covers:

Illustrative example of subject matter classified in this group:

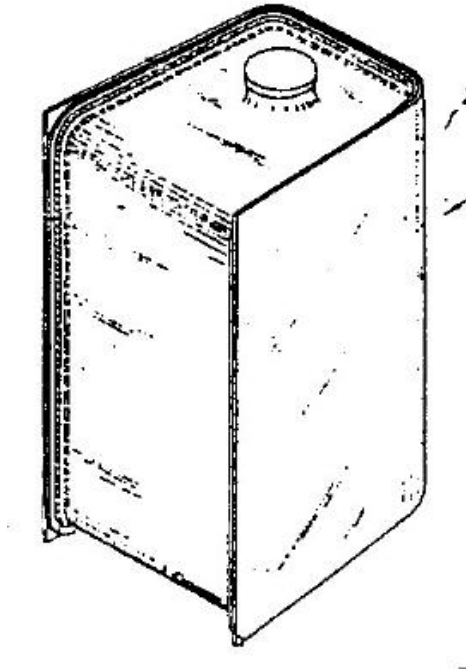
**References****Informative references**

Attention is drawn to the following places, which may be of interest for search:

The container being formed by two mating halves the two mating halves being U-shaped and connected to each other after a rotation of 90 degrees	B65D 11/1886
---	------------------------------

B65D 11/12

{of drawer-and-shell type}

References**Limiting references**

This place does not cover:

Made of paper	B65D 5/38
---------------	---------------------------

B65D 11/14

{of skeleton or apertured construction, e.g. baskets or carriers made up of interconnected spaced bands, rods, or strips}

Definition statement

This place covers:

Illustrative example of subject matter classified in this group:

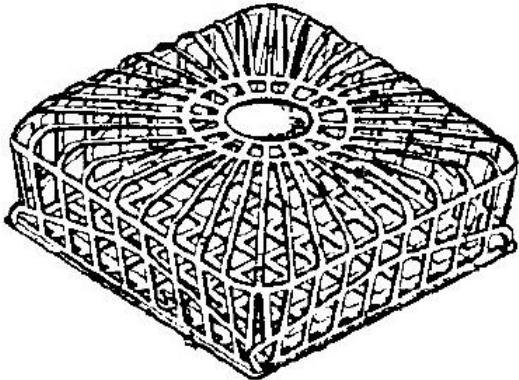
**References****Informative references**

Attention is drawn to the following places, which may be of interest for search:

Baskets or like containers of skeleton or apertured construction	B65D 1/38
Net-like containers made of plastics material	B65D 29/04

B65D 11/16

{with double walls}

Definition statement

This place covers:

Illustrative example of subject matter classified in this group:

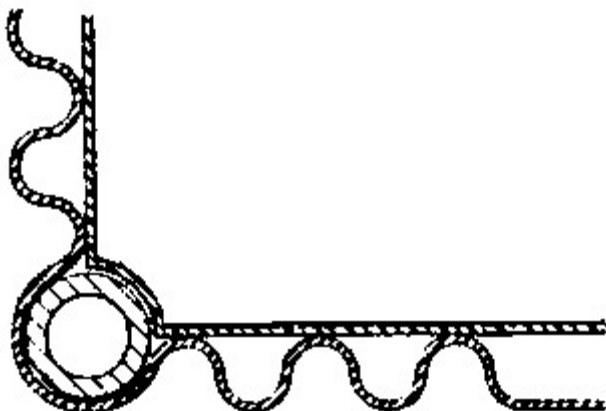

B65D 11/18

{collapsible, i.e. with walls hinged together or detachably connected}

References**Limiting references**

This place does not cover:

Made of one piece	B65D 1/225
-------------------	----------------------------

B65D 11/1806

{comprising two side walls hinged to a base panel and two other side walls being extensions hinged to said side walls}

Definition statement

This place covers:

Illustrative example of subject matter classified in this group:

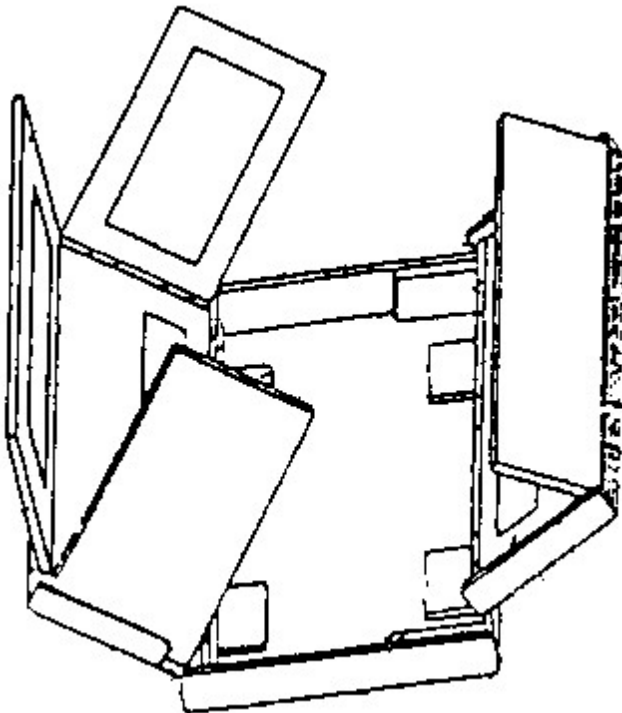
**References****Limiting references**

This place does not cover:

Made of one piece	B65D 1/225
-------------------	----------------------------

B65D 11/1813

{and one or more side walls being foldable along a median line}

References**Limiting references**

This place does not cover:

Made of one piece	B65D 1/225
-------------------	----------------------------

B65D 11/182

{comprising two side walls hinged along the sides of a base panel and to an upper frame and two other side walls being hinged only to the upper frame}

References**Limiting references**

This place does not cover:

Made of one piece	B65D 1/225
-------------------	----------------------------

B65D 11/1826

{and one or more side walls being foldable along a median line}

Definition statement

This place covers:

Illustrative example of subject matter classified in this group:

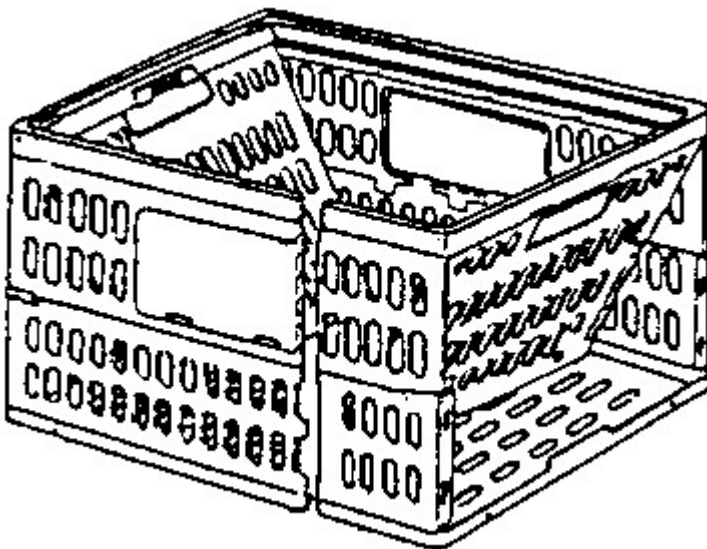

References

Limiting references

This place does not cover:

Made of one piece	B65D 1/225
-------------------	----------------------------

B65D 11/1833

{whereby all side walls are hingedly connected to the base panel ([B65D 11/186](#) takes precedence)}

Definition statement

This place covers:

Illustrative example of subject matter classified in this group:

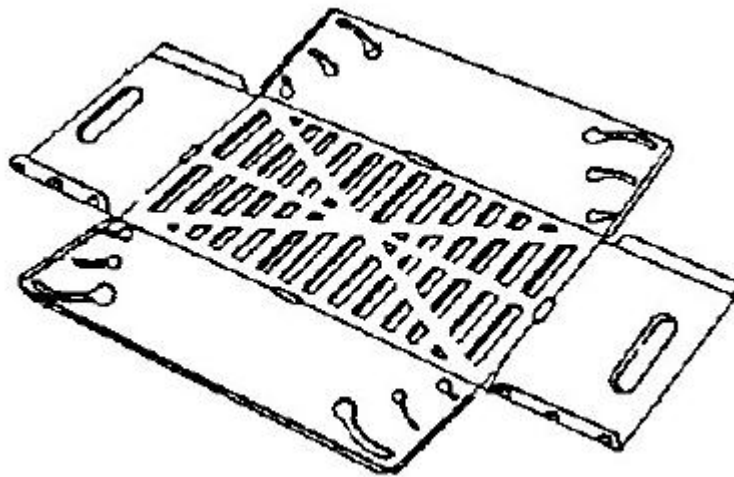

References

Limiting references

This place does not cover:

Made of one piece	B65D 1/225
Whereby all side walls are hingedly connected to the base panel and to each other to allow automatic collapsing and reerecting, e.g. by means of folds provided in the side walls and or in the base panel	B65D 11/186

B65D 11/184

{and one or more side walls being foldable along a median line}

References

Limiting references

This place does not cover:

Made of one piece	B65D 1/225
-------------------	----------------------------

B65D 11/1846

{whereby all side walls are hingedly connected to each other ([B65D 11/186](#) takes precedence)}

Definition statement

This place covers:

Illustrative example of subject matter classified in this group:

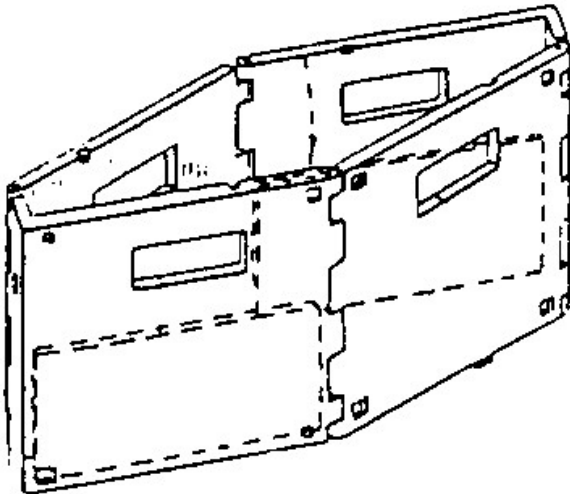
**References****Limiting references**

This place does not cover:

Made of one piece	B65D 1/225
Whereby all side walls are hingedly connected to the base panel and to each other to allow automatic collapsing and reerecting, e.g. by means of folds provided in the side walls and or in the base panel	B65D 11/186

B65D 11/1853

{and one or more side walls being foldable along a median line}

References**Limiting references**

This place does not cover:

Made of one piece	B65D 1/225
-------------------	----------------------------

B65D 11/186

{whereby all side walls are hingedly connected to the base panel and to each other to allow automatic collapsing and reerecting, e.g. by means of folds provided in the side walls and or in the base panel}

Definition statement

This place covers:

Illustrative example of subject matter classified in this group:

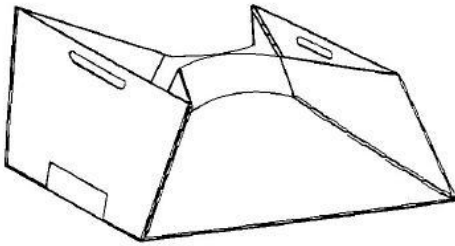
**References****Limiting references**

This place does not cover:

Made of one piece	B65D 1/225
-------------------	----------------------------

B65D 11/1866

{with detachable components ([B65D 11/1893](#) takes precedence)}

References**Limiting references**

This place does not cover:

Collapsible, with semidetachable components	B65D 11/1893
---	------------------------------

B65D 11/1873

{all walls are detached from each other to collapse the container}

Definition statement

This place covers:

Illustrative example of subject matter classified in this group:

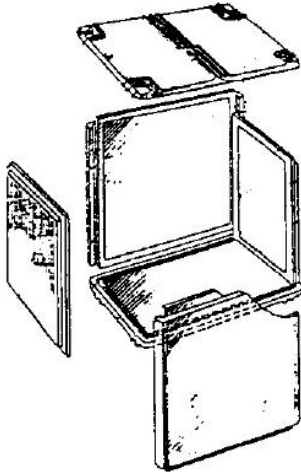

References

Limiting references

This place does not cover:

Modular elements for containers of variable capacity	B65D 21/083
--	-----------------------------

B65D 11/188

{the container being formed by two mating halves}

Definition statement

This place covers:

Illustrative example of subject matter classified in this group:

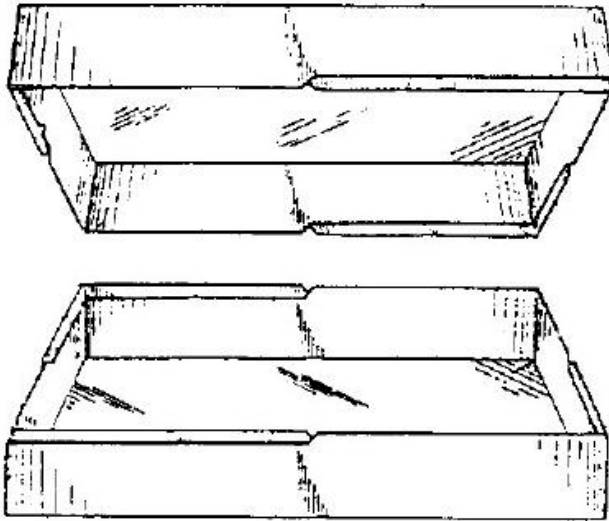
**References****Limiting references**

This place does not cover:

Permanently connected	B65D 11/10
-----------------------	----------------------------

Informative references

Attention is drawn to the following places, which may be of interest for search:

Nestable or stackable container parts forming a receptacle when one part is inverted upon the other	B65D 21/0234
---	------------------------------

B65D 11/1886

{the two mating halves being U-shaped and connected to each other after a rotation of 90 degrees}

Definition statement

This place covers:

Illustrative example of subject matter classified in this group:

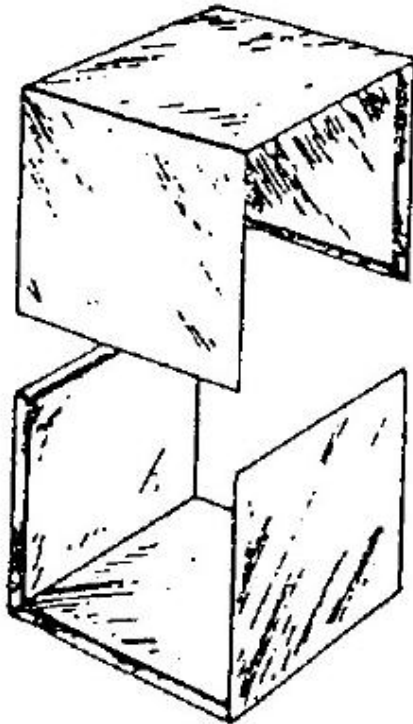

References

Informative references

Attention is drawn to the following places, which may be of interest for search:

The container being formed by two mating U-shaped halves connected to each other after a rotation of 90 degrees	B65D 11/105
---	-----------------------------

B65D 11/1893

{with semidetachable components, i.e. with some side walls hinged to each other or to a base panel and the other side walls being detachable to allow collapsing of the container}

Definition statement

This place covers:

Illustrative example of subject matter classified in this group:

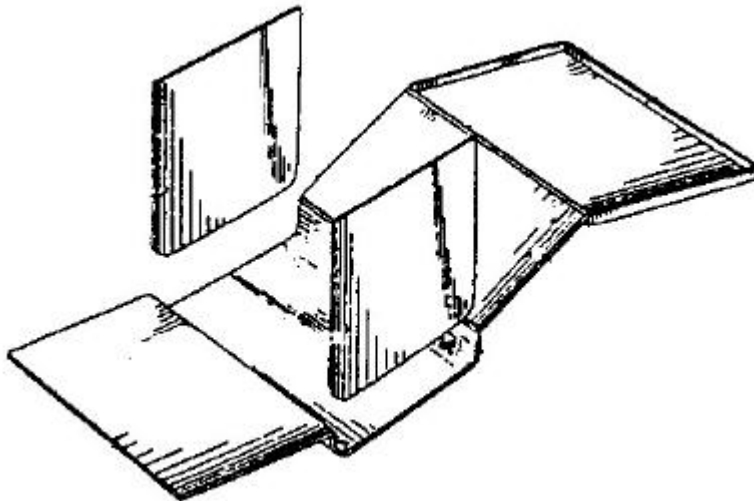

B65D 11/24

{Corrugations}

Definition statement

This place covers:

Illustrative example of subject matter classified in this group:

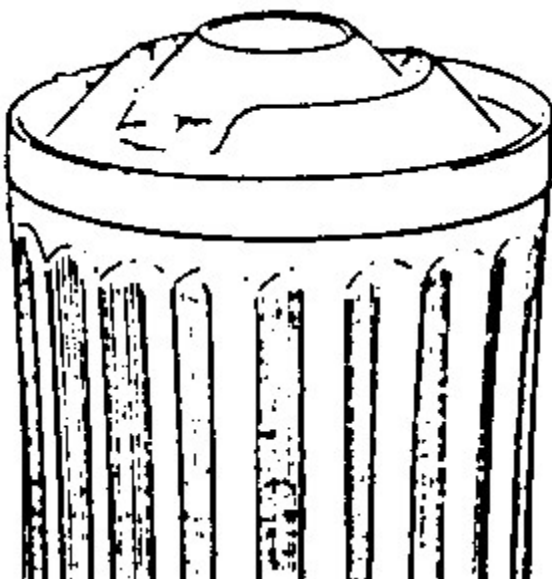

B65D 11/26

{Local reinforcements, e.g. adjacent to closures}

Definition statement

This place covers:

Illustrative example of subject matter classified in this group:



B65D 11/28

{Metal reinforcements, e.g. metal frames}

Definition statement

This place covers:

Illustrative example of subject matter classified in this group:

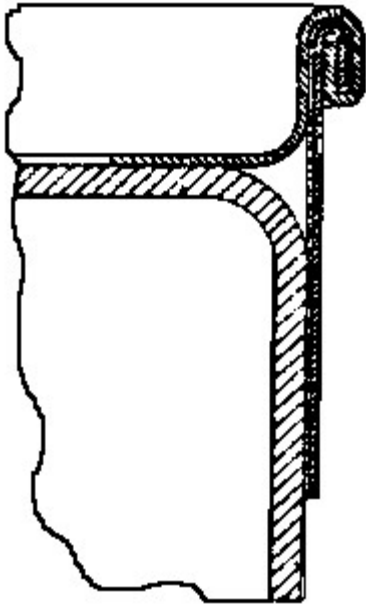

B65D 13/02

of glass, pottery, or other ceramic material

Definition statement

This place covers:

Illustrative example of subject matter classified in this group:

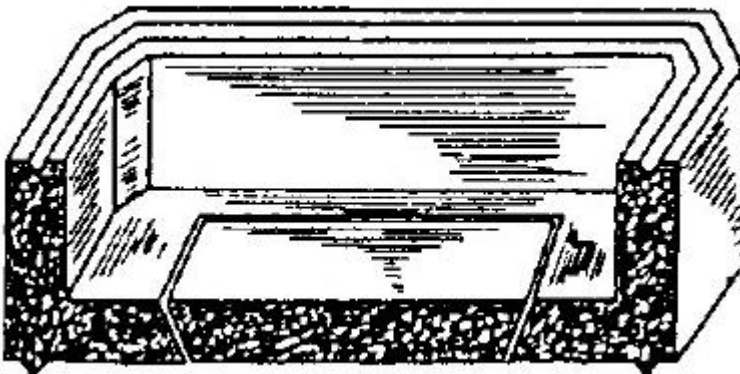

B65D 15/04

{with curved, or partially curved, walls made by winding or bending paper}

References**Limiting references**

This place does not cover:

Made wholly of paper	B65D 3/00
----------------------	---------------------------

B65D 15/06

{with end walls made of metal}

Definition statement

This place covers:

Illustrative example of subject matter classified in this group:

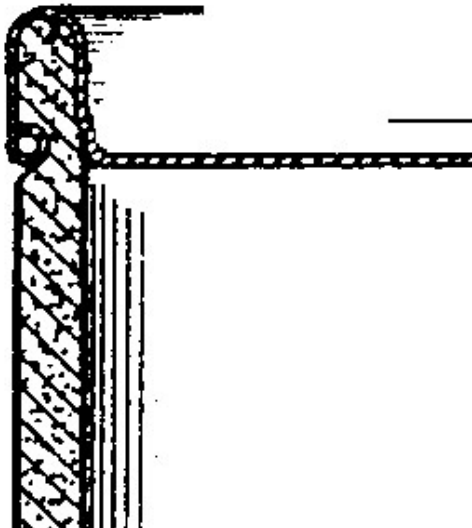

B65D 15/08

{with end walls made of plastics material}

Definition statement

This place covers:

Illustrative example of subject matter classified in this group:

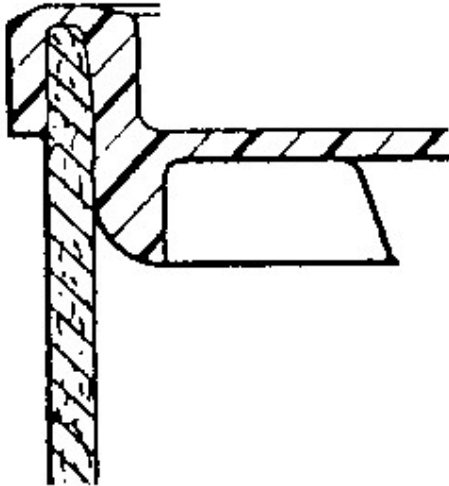

B65D 15/12

{with end walls made of paper}

Definition statement

This place covers:

Illustrative example of subject matter classified in this group:

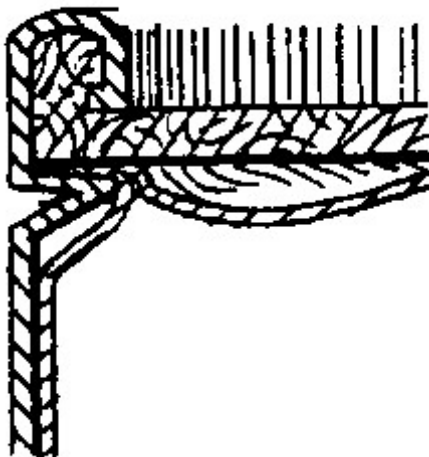

B65D 15/14

{with end walls made of plastics material}

Definition statement

This place covers:

Illustrative example of subject matter classified in this group:

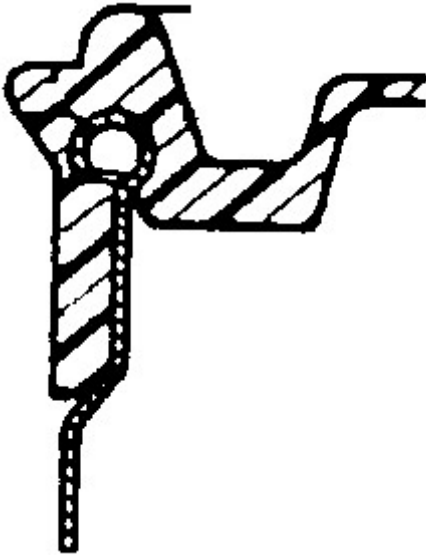

B65D 15/18

{with end walls made of metal}

Definition statement

This place covers:

Illustrative example of subject matter classified in this group:

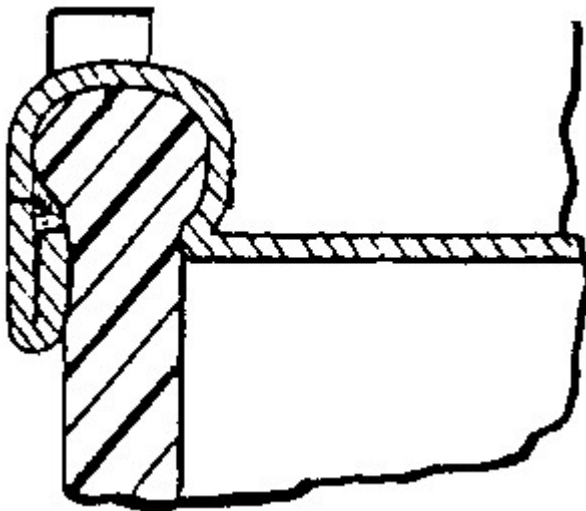

B65D 15/20

{with end walls made of paper}

Definition statement

This place covers:

Illustrative example of subject matter classified in this group:

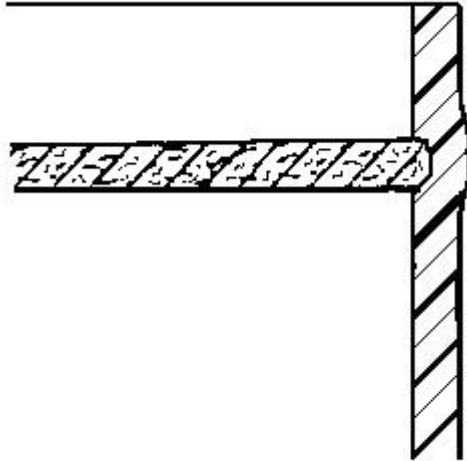

B65D 15/22

{of polygonal cross-section}

Definition statement

This place covers:

Illustrative example of subject matter classified in this group:

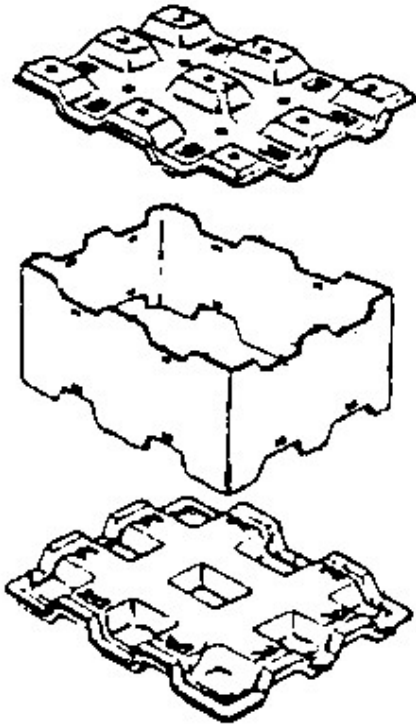

B65D 17/00

Rigid or semi-rigid containers specially constructed to be opened by cutting or piercing, or by tearing of frangible members or portions ({containers made of paper [B65D 3/00](#), [B65D 5/00](#);} frangible inner closure members associated with caps, lids or covers [B65D 51/20](#))

Definition statement

This place covers:

Illustrative example of subject matter classified in this group:

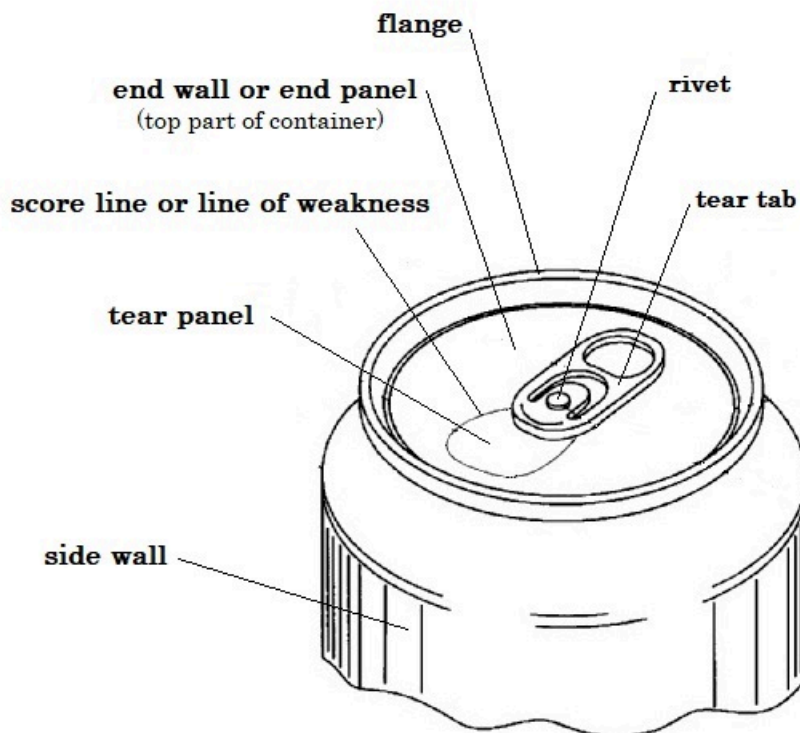

Typical beverage can with a list of its components and terms usually found in the [B65D 17/00](#) patent literature.

References

Limiting references

This place does not cover:

Opening arrangements or devices for containers made by winding, bending or folding paper	B65D 3/00 , B65D 5/00
Frangible inner closure members associated with caps, lids or covers	B65D 51/20

Informative references

Attention is drawn to the following places, which may be of interest for search:

Opening devices added or incorporated during filling or closing of containers	B65D 77/30
Manufacture of metal containers, closures, e.g. caps	B21D 51/00
Separate devices for opening closed containers	B67B 7/00

Special rules of classification

The use of [B65D 2517/00](#)-series Indexing Codes is mandatory.

B65D 17/06

{Integral, or permanently secured, end or side closures}

References**Informative references**

Attention is drawn to the following places, which may be of interest for search:

Integral frangible closures	B65D 1/0238
-----------------------------	-----------------------------

Special rules of classification

The use of [B65D 2517/00](#)-series Indexing Codes is mandatory.

B65D 17/08

{Closures secured by folding or rolling and pressing}

Definition statement

This place covers:

Illustrative example of subject matter classified in this group:

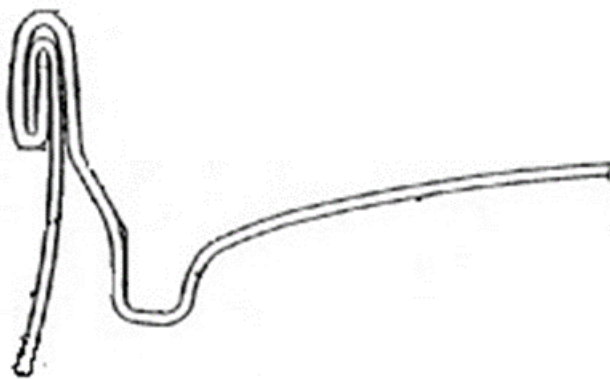

References

Informative references

Attention is drawn to the following places, which may be of interest for search:

With permanent connections between walls, formed by rolling, or by rolling and pressing	B65D 7/36
Reusable closures	B65D 43/0233 , B65D 43/0285
By applying separate lids or covers the cover being maintained on the container by mechanical means	B65D 77/2004

Special rules of classification

The use of [B65D 2517/00](#)-series Indexing Codes is mandatory.

B65D 17/10

{with interposed packing rings}

Definition statement

This place covers:

Illustrative example of subject matter classified in this group:

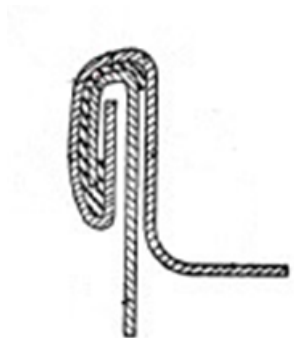

References

Informative references

Attention is drawn to the following places, which may be of interest for search:

Reusable closures	B65D 43/0233 , B65D 43/0285
-------------------	--

Special rules of classification

The use of [B65D 2517/00](#)-series Indexing Codes is mandatory.

B65D 17/12

{Closures secured by soldering, welding, or otherwise uniting opposed surfaces}

Definition statement

This place covers:

Illustrative example of subject matter classified in this group:

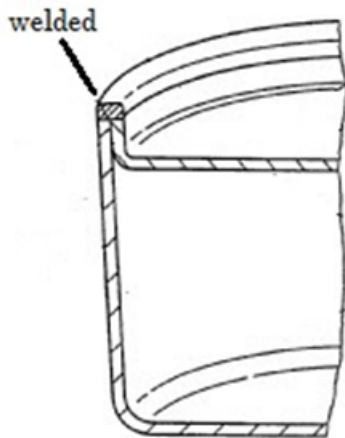

References

Informative references

Attention is drawn to the following places, which may be of interest for search:

Formed by soldering, welding, or otherwise uniting opposed surfaces	B65D 7/38
---	---------------------------

Special rules of classification

The use of [B65D 2517/00](#)-series Indexing Codes is mandatory.

B65D 17/30**using cutting devices****Definition statement**

This place covers:

Illustrative example of subject matter classified in this group:

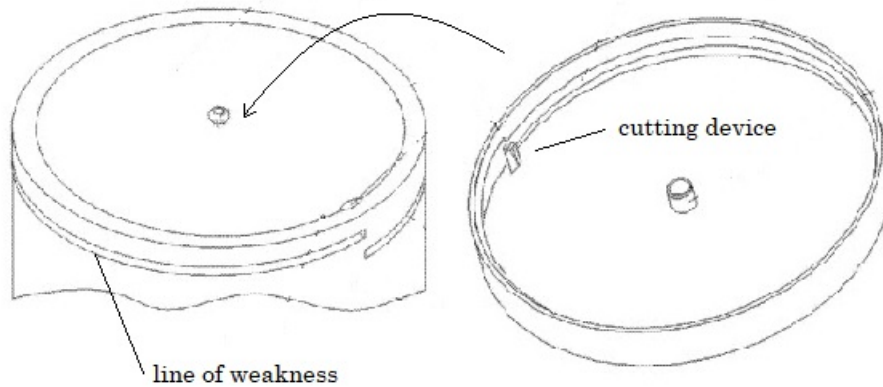

The cutting device is specially adapted to the line of weakness of the container.

References**Informative references**

Attention is drawn to the following places, which may be of interest for search:

Attached can-cutting devices	B65D 17/521
------------------------------	-----------------------------

Special rules of classification

The use of [B65D 2517/00](#)-series Indexing Codes is mandatory.

B65D 17/32**having non-detachable members or portions****Definition statement**

This place covers:

Illustrative example of subject matter classified in this group:

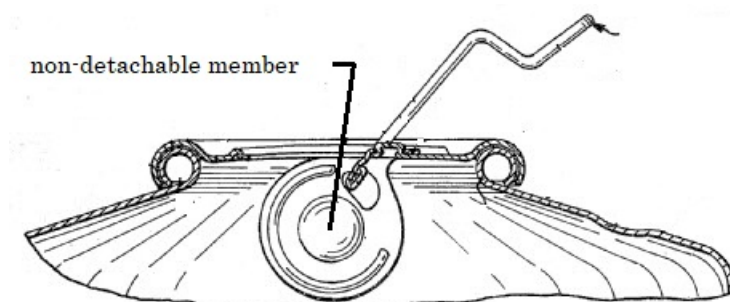

The torn end wall part remains attached to the container.

References

Informative references

Attention is drawn to the following places, which may be of interest for search:

Arrangement or construction of pull or lift tabs	B65D 17/34
--	----------------------------

Special rules of classification

The use of [B65D 2517/00](#)-series Indexing Codes is mandatory.

The non-detachable members or portions are understood to be the torn part of the end wall, i.e. the tear panel, and not the tear tab.

Note: most documents classified with [B65D 2517/0011](#), [B65D 2517/0014](#), [B65D 2517/0017](#) and [B65D 2517/0019](#) Indexing Codes would also require a classification in [B65D 17/32](#).

B65D 17/34

Arrangement or construction of pull or lift tabs ([B65D 17/32](#) takes precedence)

Definition statement

This place covers:

Illustrative example of subject matter classified in this group:

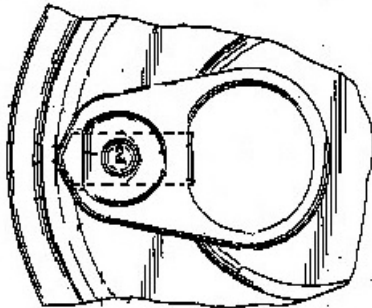

References

Limiting references

This place does not cover:

Having non-detachable members or portions	B65D 17/32
---	----------------------------

Special rules of classification

The use of [B65D 2517/00](#)-series Indexing Codes is mandatory.

B65D 17/353

the connecting means being integral with the tab or with the detachable member or portion

Definition statement

This place covers:

Illustrative example of subject matter classified in this group:

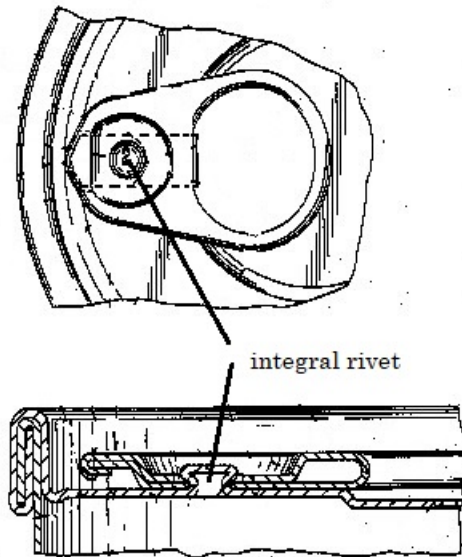

Special rules of classification

The use of [B65D 2517/00](#)-series Indexing Codes is mandatory.

B65D 17/38

with strip or tool guides

Definition statement

This place covers:

Illustrative example of subject matter classified in this group:

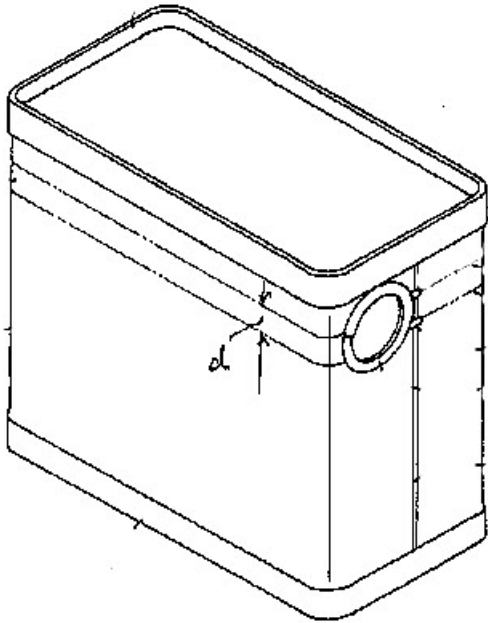

References

Informative references

Attention is drawn to the following places, which may be of interest for search:

With tongues or tags for engagement by slotted keys	B65D 17/464
---	-----------------------------

Special rules of classification

The use of [B65D 2517/00](#)-series Indexing Codes is mandatory.

B65D 17/401

{characterised by having the line of weakness provided in an end wall}

Definition statement

This place covers:

Illustrative example of subject matter classified in this group:

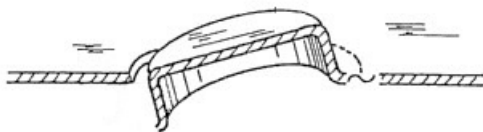
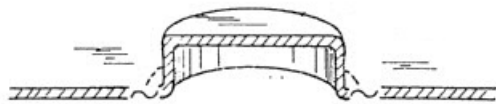
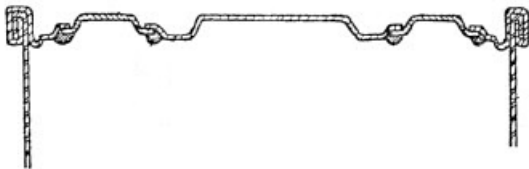
**References****Informative references**

Attention is drawn to the following places, which may be of interest for search:

Pour spouts, nozzles, tubes having frangible closures	B65D 47/10
Closures with venting means whereby venting occurs by rupturing a portion of the closure	B65D 51/1677

Special rules of classification

The use of [B65D 2517/00](#)-series Indexing Codes is mandatory.

B65D 17/4011

{for opening completely by means of a tearing tab}

Definition statement

This place covers:

Illustrative example of subject matter classified in this group:

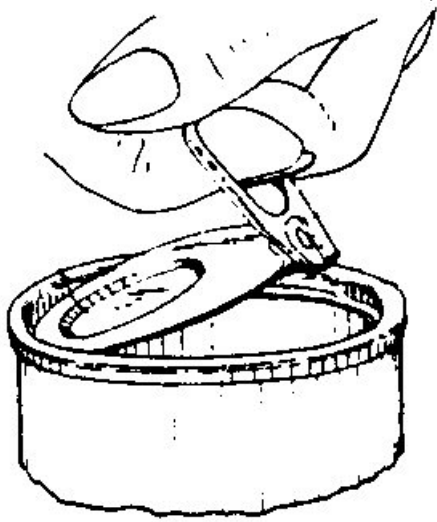

A large part of, or the entire end wall is opened.

References

Informative references

Attention is drawn to the following places, which may be of interest for search:

Membranes with a tearing element	B65D 47/103
----------------------------------	-----------------------------

Special rules of classification

The use of [B65D 2517/00](#)-series Indexing Codes is mandatory.

B65D 17/4012**{for opening partially by means of a tearing tab}****Definition statement***This place covers:*

Illustrative example of subject matter classified in this group:

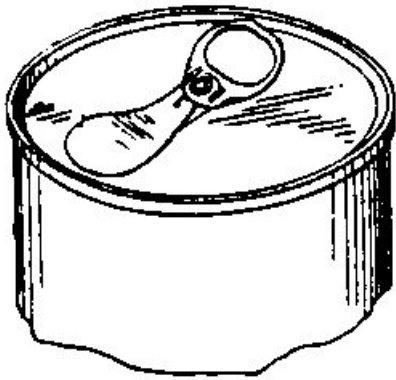

Only a part of the end wall is opened, e.g. typical beverage can

References***Informative references****Attention is drawn to the following places, which may be of interest for search:*

Break-in flaps, or members adapted to be torn-off, to provide pouring openings	B65D 5/70
Membranes with a tearing element	B65D 47/103

Special rules of classificationThe use of [B65D 2517/00](#)-series Indexing Codes is mandatory.

B65D 17/402

{characterised by having the line of weakness provided in the side wall
([B65D 17/46](#) takes precedence)}

Definition statement

This place covers:

Illustrative example of subject matter classified in this group:

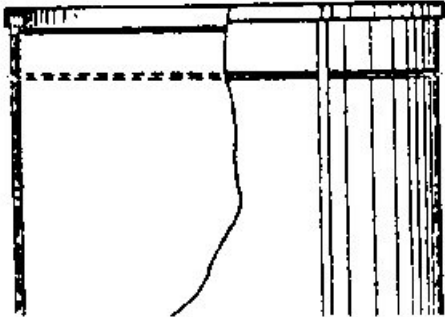
**References****Limiting references**

This place does not cover:

Wires, strings or the like, e.g. rip cords	B65D 17/46
--	----------------------------

Informative references

Attention is drawn to the following places, which may be of interest for search:

For bottles	B65D 1/0223
Lines of weakness facilitating opening of carton containers, e.g. carton boxes	B65D 5/54

Special rules of classification

The use of [B65D 2517/00](#)-series Indexing Codes is mandatory.

B65D 17/404**{Details of the lines of weakness}****Definition statement***This place covers:*

Illustrative example of subject matter classified in this group:

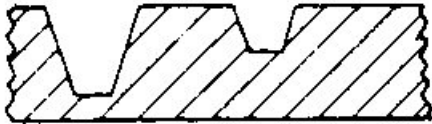

For example details of the depth or shape of the line of weakness.

Special rules of classificationThe use of [B65D 2517/00](#)-series Indexing Codes is mandatory.**B65D 17/42****with cutting, punching, or cutter accommodating means (for opening at lines or points of weakness [B65D 17/28](#))****Definition statement***This place covers:*

Illustrative example of subject matter classified in this group:

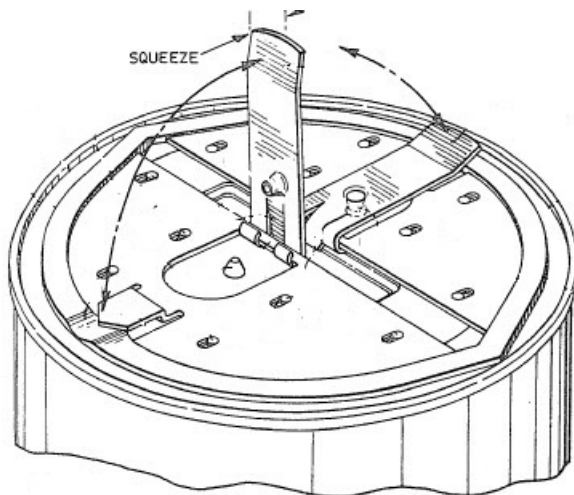
**References****Limiting references***This place does not cover:*

For opening at lines or points of weakness	B65D 17/28
--	----------------------------

Informative references

Attention is drawn to the following places, which may be of interest for search:

Attached can-cutting devices	B65D 17/521
------------------------------	-----------------------------

Special rules of classification

The use of [B65D 2517/00](#)-series Indexing Codes is mandatory.

B65D 17/44

in which the puncturing tool serves as closure

Definition statement

This place covers:

Illustrative example of subject matter classified in this group:

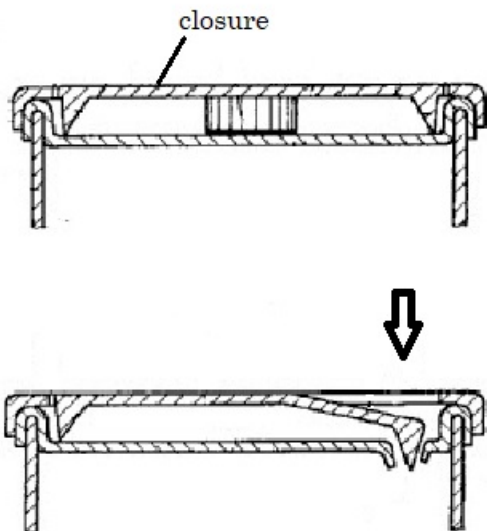
**Special rules of classification**

The use of [B65D 2517/00](#)-series Indexing Codes is mandatory.

B65D 17/462**{Tearing-strips or -wires}****Definition statement***This place covers:*

Illustrative example of subject matter classified in this group:

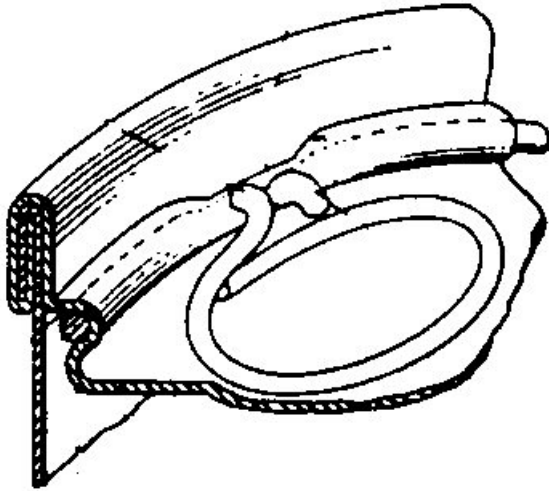
**References*****Informative references****Attention is drawn to the following places, which may be of interest for search:*

Inserted or applied tearing-strings or like flexible elements	B65D 75/66
Tearing-strings or like flexible elements	B65D 77/32

Special rules of classificationThe use of [B65D 2517/00](#)-series Indexing Codes is mandatory.

B65D 17/464

{with tongues or tags for engagement by slotted keys}

Definition statement

This place covers:

Illustrative example of subject matter classified in this group:

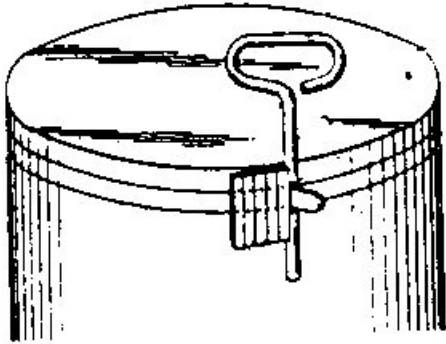
**Special rules of classification**

The use of [B65D 2517/00](#)-series Indexing Codes is mandatory.

B65D 17/48

located in the seam-adjointing parts of the container

Definition statement

This place covers:

Illustrative example of subject matter classified in this group:

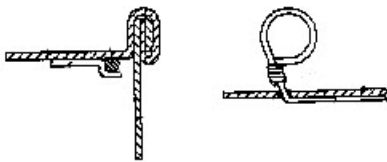
**Special rules of classification**

The use of [B65D 2517/00](#)-series Indexing Codes is mandatory.

B65D 17/50

Non-integral frangible members applied to, or inserted in, preformed openings, e.g. tearable strips or plastic plugs ([B65D 53/08](#) takes precedence)

References**Informative references**

Attention is drawn to the following places, which may be of interest for search:

Separate tearable flexible elements covering a discharge opening of a container	B65D 5/708
Separate closure devices for reclosing opened cans or tins, e.g. beer cans	B65D 51/007
Preformed openings provided in a wall portion and covered by a separate removable flexible element	B65D 75/5894

Special rules of classification

The use of available Indexing Codes is mandatory.

B65D 17/501

{Flexible tape or foil-like material}

References**Informative references**

Attention is drawn to the following places, which may be of interest for search:

Flexible adhesive strips adapted to seal filling or discharging apertures	B65D 53/08
---	----------------------------

Special rules of classification

The use of available Indexing Codes is mandatory.

B65D 17/502

{applied to the external part of the container wall only}

Definition statement

This place covers:

Illustrative example of subject matter classified in this group:

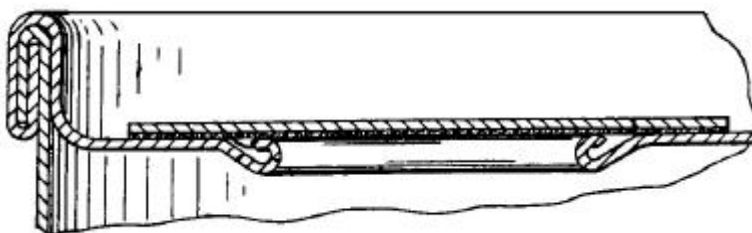

References

Informative references

Attention is drawn to the following places, which may be of interest for search:

Flexible tape or foil-like material applied to the external and internal part of the container wa	B65D 17/505
Flexible adhesive strips adapted to seal filling or discharging apertures	B65D 53/08

Special rules of classification

The use of available Indexing Codes is mandatory.

B65D 17/503

{applied to the internal part of the container wall only}

Definition statement

This place covers:

Illustrative example of subject matter classified in this group:

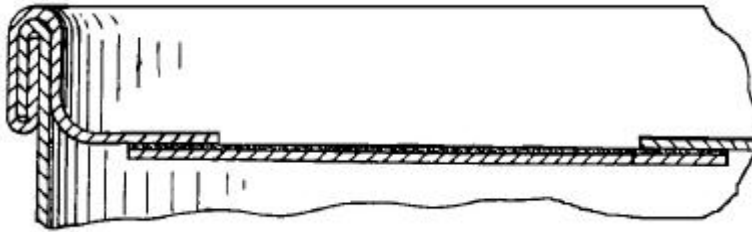

References

Informative references

Attention is drawn to the following places, which may be of interest for search:

Flexible tape or foil-like material applied to the external and internal part of the container wall	B65D 17/505
Flexible adhesive strips adapted to seal filling or discharging apertures	B65D 53/08

Special rules of classification

The use of available Indexing Codes is mandatory.

B65D 17/505

{applied to the external and internal part of the container wall}

Definition statement

This place covers:

Illustrative example of subject matter classified in this group:

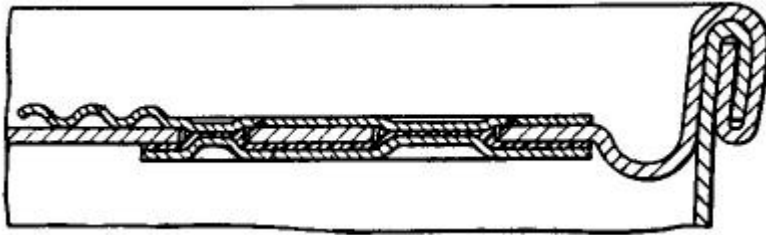
**References****Informative references**

Attention is drawn to the following places, which may be of interest for search:

Flexible adhesive strips adapted to seal filling or discharging apertures	B65D 53/08
---	----------------------------

Special rules of classification

The use of available Indexing Codes is mandatory.

B65D 17/506

{Rigid or semi-rigid members, e.g. plugs}

Definition statement

This place covers:

Illustrative example of subject matter classified in this group:

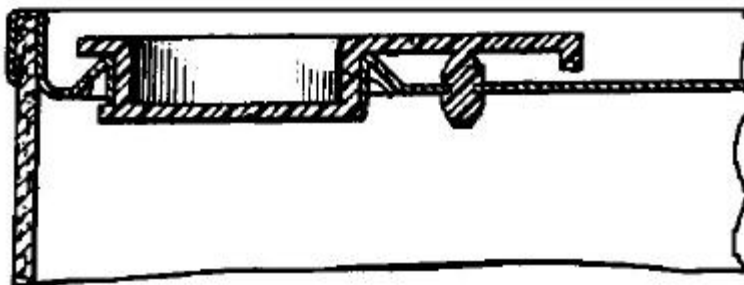
**References****Limiting references**

This place does not cover:

Separate closure devices for reclosing opening cans, tins, e.g. beer cans	B65D 51/007
---	-----------------------------

Special rules of classification

The use of available Indexing Codes is mandatory.

B65D 17/507

{moulded in situ, e.g. during production of container}

Definition statement

This place covers:

Illustrative example of subject matter classified in this group:

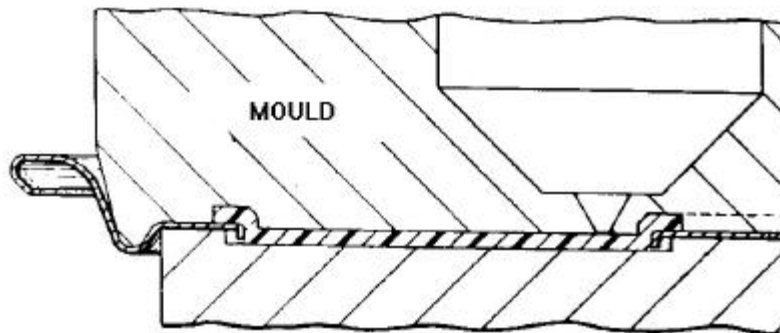
**References****Limiting references**

This place does not cover:

Moulding in or through a hole of the article	B29C 45/14344
--	-------------------------------

Special rules of classification

The use of available Indexing Codes is mandatory.

B65D 17/508

{and combined with a rigid or semi-rigid, e.g. metallic sheet and a moulded plastic body}

Definition statement

This place covers:

Illustrative example of subject matter classified in this group:

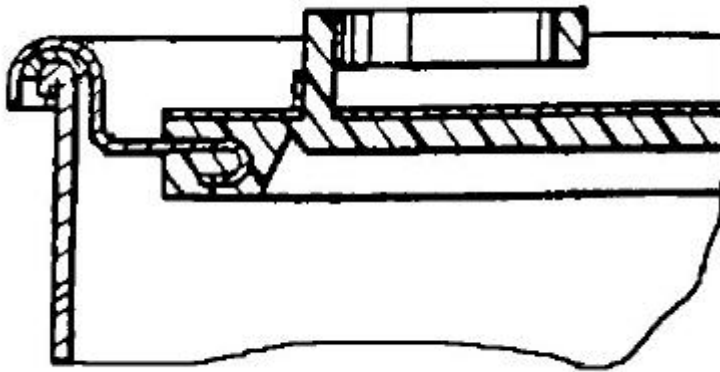
**Special rules of classification**

The use of available Indexing Codes is mandatory.

B65D 17/521

{Attached can-cutting devices}

Definition statement

This place covers:

Illustrative example of subject matter classified in this group:

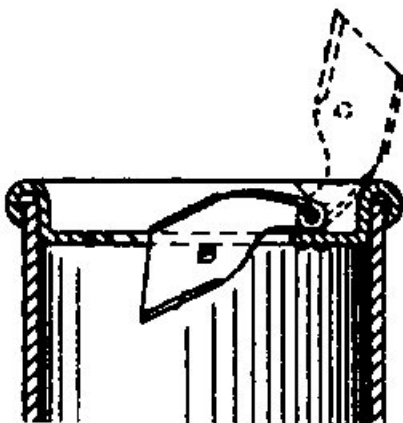
**Special rules of classification**

The use of [B65D 2517/00](#)-series Indexing Codes is mandatory.

B65D 17/523**{Attachments of slotted keys to preserving cans or tins}****Definition statement***This place covers:*

Illustrative example of subject matter classified in this group:

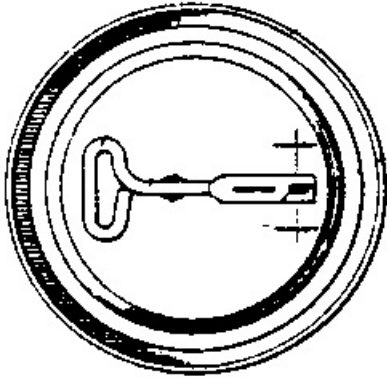
**Special rules of classification**The use of [B65D 2517/00](#)-series Indexing Codes is mandatory.**B65D 19/00****Pallets or like platforms, with or without side walls, for supporting loads to be lifted or lowered (in devices for lifting or lowering bulky or heavy goods for loading or unloading purposes [B66F 9/12](#))****References****Limiting references***This place does not cover:*

Slip sheets	B65D 19/36
Spillage retaining means	B65D 81/26 , B65D 90/24
Trays for tools or instruments for workshops	B25H 3/06
Devices for adapting aircraft pallets to the shape of the aircraft	B64D 9/00
Transport frames for fragile sheets	B65G 49/061

Special rules of classification

The use of available Indexing Codes is mandatory.

B65D 19/0002

{Platforms, i.e. load supporting devices without provision for handling by a forklift}

References**Limiting references**

This place does not cover:

For large platforms	B65D 88/129
---------------------	-----------------------------

Informative references

Attention is drawn to the following places, which may be of interest for search:

Rigid pallets without side walls	B65D19/22
----------------------------------	------------------

Special rules of classification

The use of available Indexing Codes is mandatory.

B65D 19/0004

{Rigid pallets without side walls}

References**Informative references**

Attention is drawn to the following places, which may be of interest for search:

Rigid pallets without side walls	B65D19/22
----------------------------------	------------------

Special rules of classification

The use of available Indexing Codes is mandatory.

B65D 19/02

Rigid pallets with side walls, e.g. box pallets

Special rules of classification

The use of available Indexing Codes is mandatory.

B65D 19/04

with bodies moulded or otherwise fabricated in one piece

Definition statement

This place covers:

Illustrative example of subject matter classified in this group:

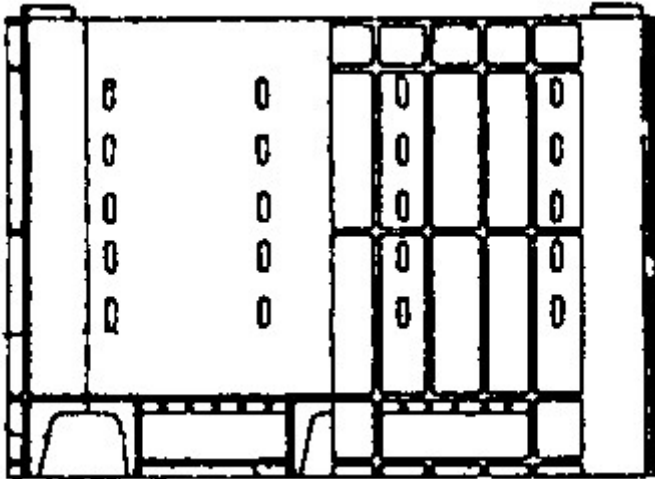
**References****Informative references**

Attention is drawn to the following places, which may be of interest for search:

For pallets made of plastic	B29L 2031/7178
-----------------------------	--------------------------------

Special rules of classification

The use of available Indexing Codes is mandatory.

B65D 19/06

with bodies formed by uniting or interconnecting two or more components

References**Informative references**

Attention is drawn to the following places, which may be of interest for search:

For pallets made of plastic	B29L 2031/7178
-----------------------------	--------------------------------

Special rules of classification

The use of available Indexing Codes is mandatory.

B65D 19/08

made wholly or mainly of metal

Definition statement

This place covers:

Illustrative example of subject matter classified in this group:

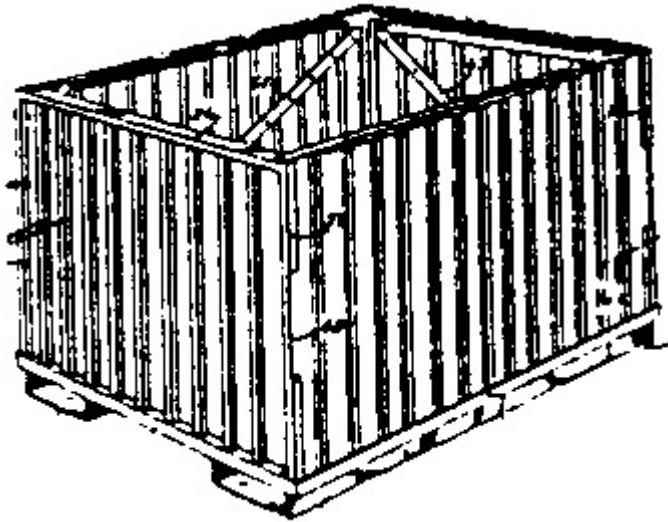

Special rules of classification

The use of available Indexing Codes is mandatory.

B65D 19/10

of skeleton construction, e.g. made of wire

Definition statement

This place covers:

Illustrative example of subject matter classified in this group:

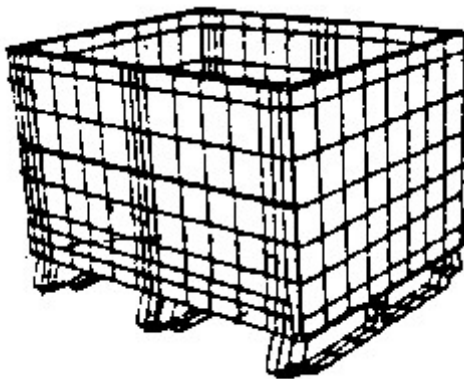

Special rules of classification

The use of available Indexing Codes is mandatory.

B65D 19/12**Collapsible pallets****Definition statement**

This place covers:

Illustrative example of subject matter classified in this group:

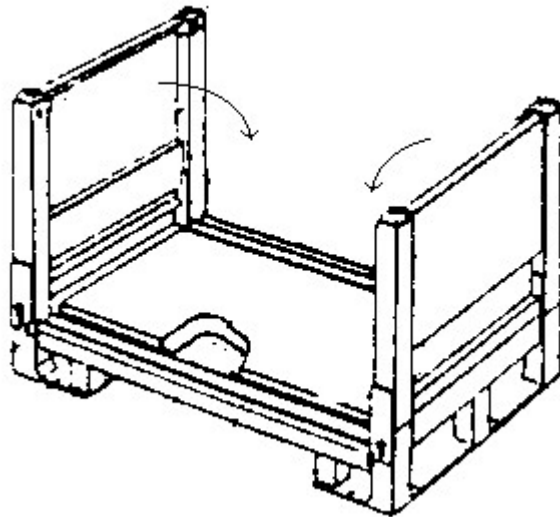
**References****Limiting references**

This place does not cover:

Frames, corner posts or pallet converters	B65D 19/385
Large containers	B65D 88/52

Informative references

Attention is drawn to the following places, which may be of interest for search:

Collapsible with all parts hinged together	B65D 7/26
--	---------------------------

Special rules of classification

The use of available Indexing Codes is mandatory.

B65D 19/14

made wholly or mainly of wood

Definition statement

This place covers:

Illustrative example of subject matter classified in this group:

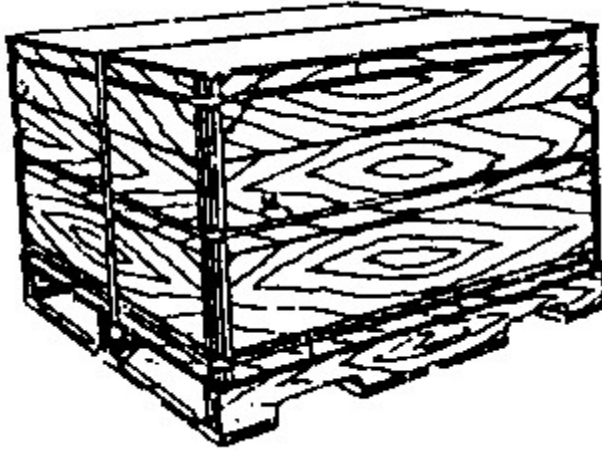

Special rules of classification

The use of available Indexing Codes is mandatory.

B65D 19/16

Collapsible pallets

Definition statement

This place covers:

Illustrative example of subject matter classified in this group:

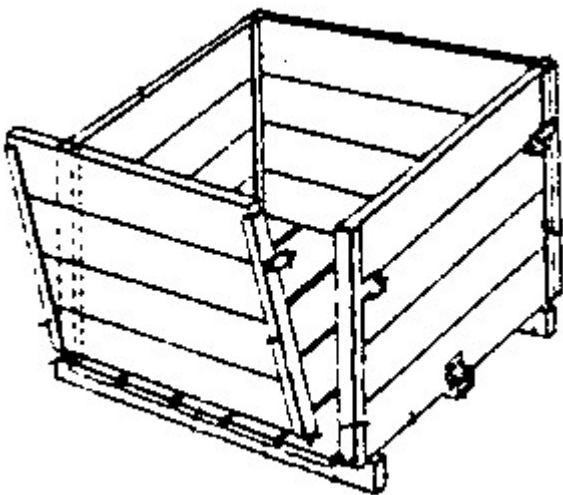

References

Informative references

Attention is drawn to the following places, which may be of interest for search:

Collapsible with all parts hinged together	B65D 9/14
--	---------------------------

Special rules of classification

The use of available Indexing Codes is mandatory.

B65D 19/18

made wholly or mainly of plastics material

Definition statement

This place covers:

Illustrative example of subject matter classified in this group:

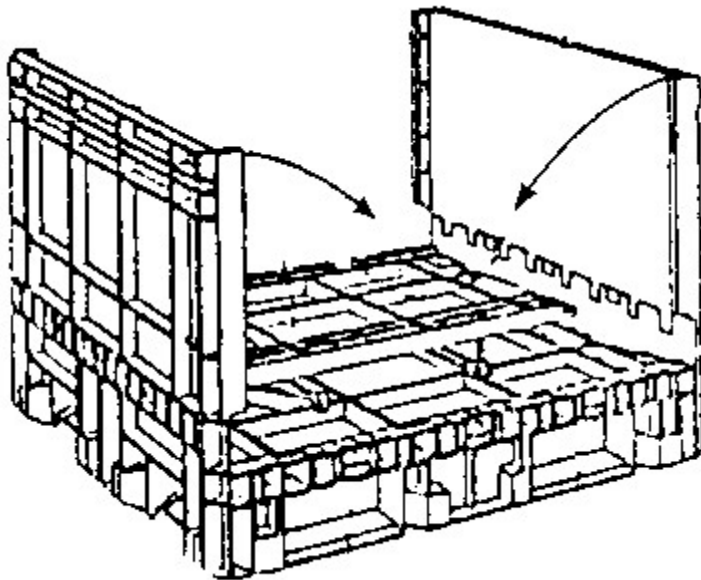

References

Informative references

Attention is drawn to the following places, which may be of interest for search:

For pallets made of plastic	B29L 2031/7178
-----------------------------	--------------------------------

B65D 19/20

made wholly or mainly of paper

Definition statement

This place covers:

Illustrative example of subject matter classified in this group:

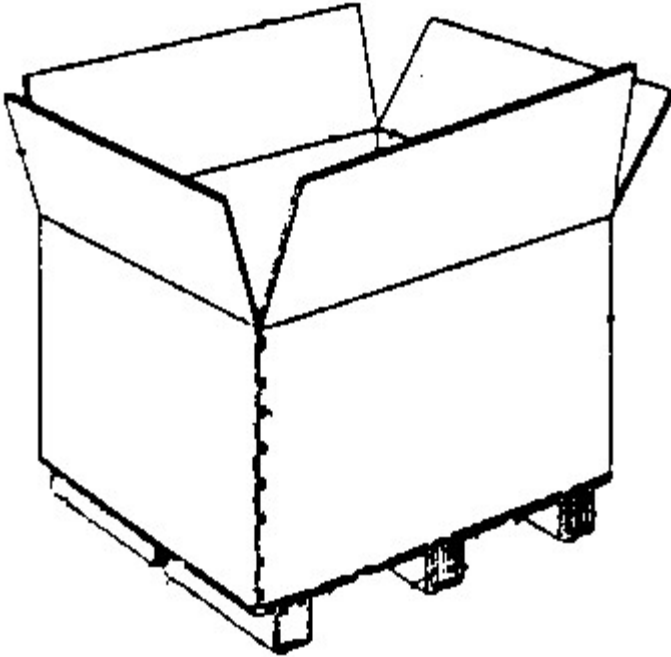

Special rules of classification

The use of available Indexing Codes is mandatory.

B65D 19/36

Pallets comprising a flexible load carrier extending between guide elements, e.g. guide tubes

Definition statement

This place covers:

Illustrative example of subject matter classified in this group:

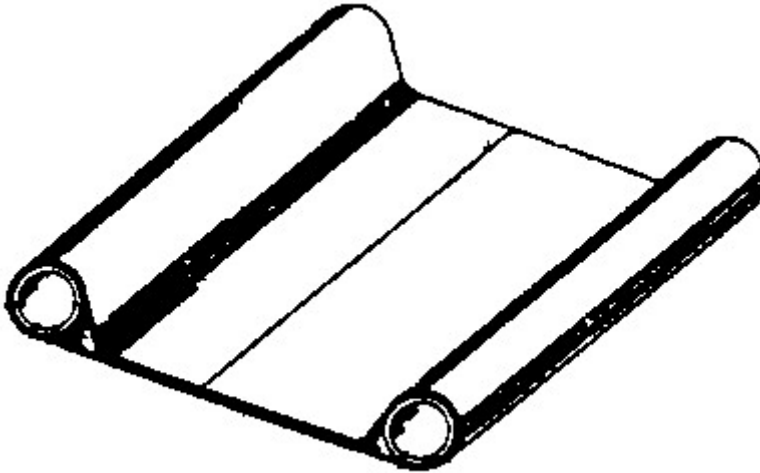
**Special rules of classification**

The use of available Indexing Codes is mandatory.

B65D 19/38

Details or accessories

References**Limiting references**

This place does not cover:

Anti-slip or anti-skid elements	B65D 19/44
---------------------------------	----------------------------

Informative references

Attention is drawn to the following places, which may be of interest for search:

Anti-slip or anti-skid coatings or other elements	B65D 33/005
---	-----------------------------

Special rules of classification

The use of available Indexing Codes is mandatory.

B65D 19/385

{Frames, corner posts or pallet converters, e.g. for facilitating stacking of charged pallets}

Definition statement

This place covers:

Illustrative example of subject matter classified in this group:

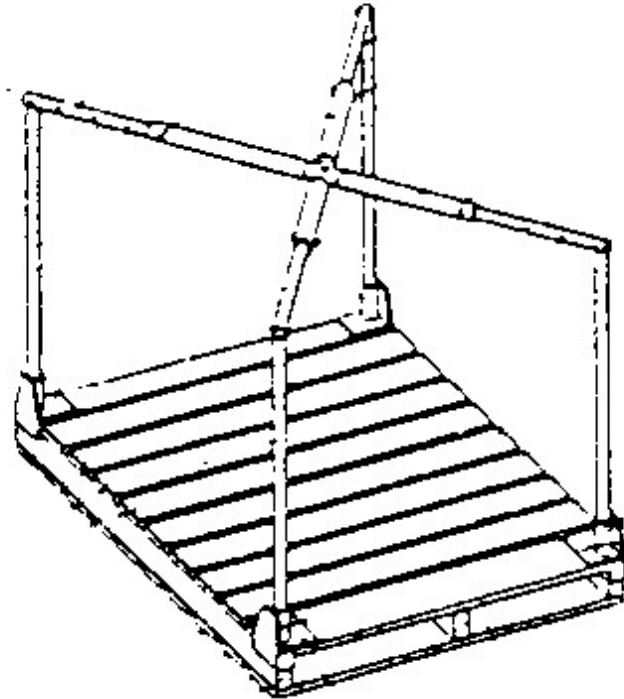
**References****Limiting references**

This place does not cover:

Stabilising columns for palletisable loads	B65D 2571/00074
--	---------------------------------

Informative references

Attention is drawn to the following places, which may be of interest for search:

Rigid pallets with side walls and with bodies formed by uniting or interconnecting two or more components	B65D 19/06
Rigid pallets with side walls and with bodies formed by uniting or interconnecting two or more components, made wholly or mainly of metal	B65D 19/08
Rigid pallets with side walls, with bodies formed by uniting or interconnecting two or more components, of skeleton construction, made wholly or mainly of metal	B65D 19/10
Rigid, collapsible pallets with side walls and with bodies formed by uniting or interconnecting two or more components, made wholly or mainly of metal	B65D 19/12

Elements or devices for locating articles on platforms	B65D 19/44
Containers with stacking feet or corner elements	B65D 21/0215

B65D 19/40

Elements for spacing platforms from supporting surface

Definition statement

This place covers:

Illustrative example of subject matter classified in this group:

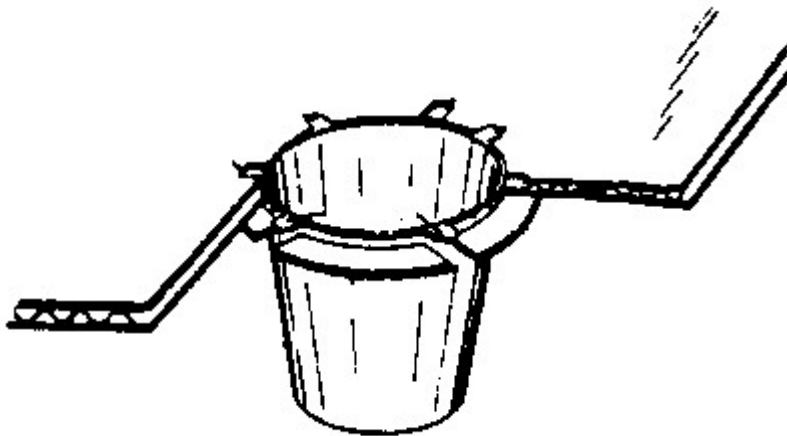

References

Limiting references

This place does not cover:

Isolated supports for palletisable loads (isolated feet)	B65D 71/0088
Isolated supports for palletisable loads (isolated skids)	B65D 71/0092

Informative references

Attention is drawn to the following places, which may be of interest for search:

External fittings for spacing bases of containers from supporting surfaces	B65D 25/24
Palletisable loads, local maintaining elements, stabilising and reinforcing columns	B65D 2571/00074
Load supporting elements (Not used)	B65D 2571/0008

Special rules of classification

The use of available Indexing Codes is mandatory.

B65D 19/42

Arrangements or applications of rollers or wheels

Definition statement

This place covers:

Illustrative example of subject matter classified in this group:

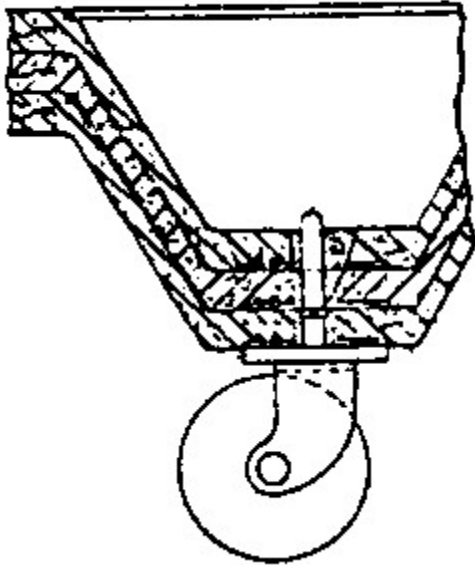

References

Informative references

Attention is drawn to the following places, which may be of interest for search:

Hand carts having more than one axis carrying transport wheels, characterised by a rectangular shape, involving side walls or racks

B62B 3/002

Special rules of classification

The use of available Indexing Codes is mandatory.

B65D 19/44

Elements or devices for locating articles on platforms

Definition statement

This place covers:

Illustrative example of subject matter classified in this group:

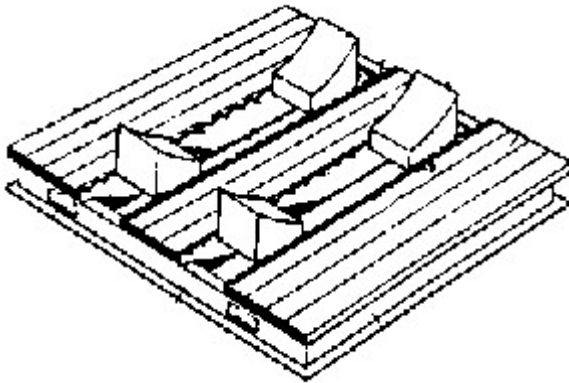

References

Limiting references

This place does not cover:

Anti-slip or anti-skid elements	B65D 19/38
Anti-slip or anti-skid bags	B65D 33/005

Special rules of classification

The use of available Indexing Codes is mandatory.

B65D 21/00

Nestable, stackable or joinable containers; Containers of variable capacity

References

Informative references

Attention is drawn to the following places, which may be of interest for search:

Multi-unit containers or multi-compartmented containers	B65D 88/1643
---	------------------------------

B65D 21/02

Containers specially shaped, or provided with fittings or attachments, to facilitate nesting, stacking, or joining together {(stackable containers of polygonal cross-section formed by folding or erecting blanks made of paper [B65D 5/001](#))}

References**Limiting references**

This place does not cover:

Drinking vessels or saucers used for table service of stackable type	A47G 19/23
--	----------------------------

B65D 21/0201

{stackable or joined together side-by-side}

Relationships with other classification places

Containers, also provided with means of different kind for stacking them one upon the other, are also classified in other [B65D 21/02](#) groups.

References**Informative references**

Attention is drawn to the following places, which may be of interest for search:

Articles joined together for convenience of storage or transport without the use of packaging elements	B65D 69/00
Cylindrical or polygonal containers	B65D 81/3283
Modular elements with complementary shapes, interengageable parts or the like	B65D 81/361

B65D 21/0202

{and loosely interengaged by integral complementary shapes}

Definition statement

This place covers:

Illustrative example of subject matter classified in this group:

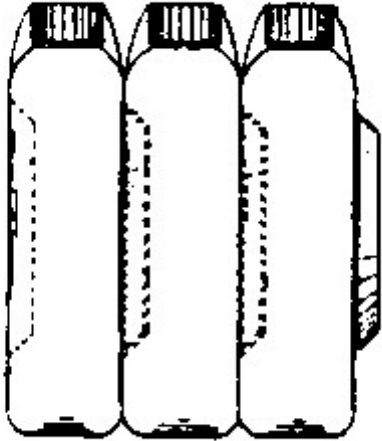

B65D 21/0204

{and joined together by interconnecting formations forming part of the container, e.g. dove-tail, snap connections, hook elements}

Definition statement

This place covers:

Illustrative example of subject matter classified in this group:

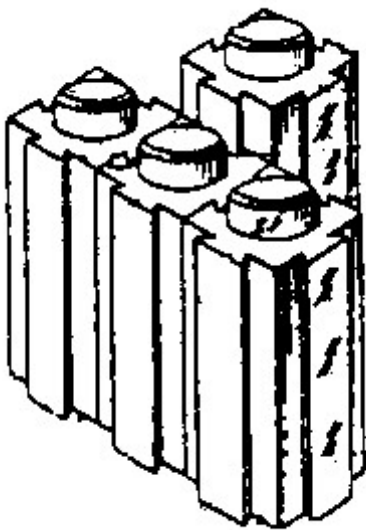

B65D 21/0205

{joined together by bonding, adhesive or the like ([B65D 21/0208](#) takes precedence)}

Definition statement

This place covers:

Illustrative example of subject matter classified in this group:

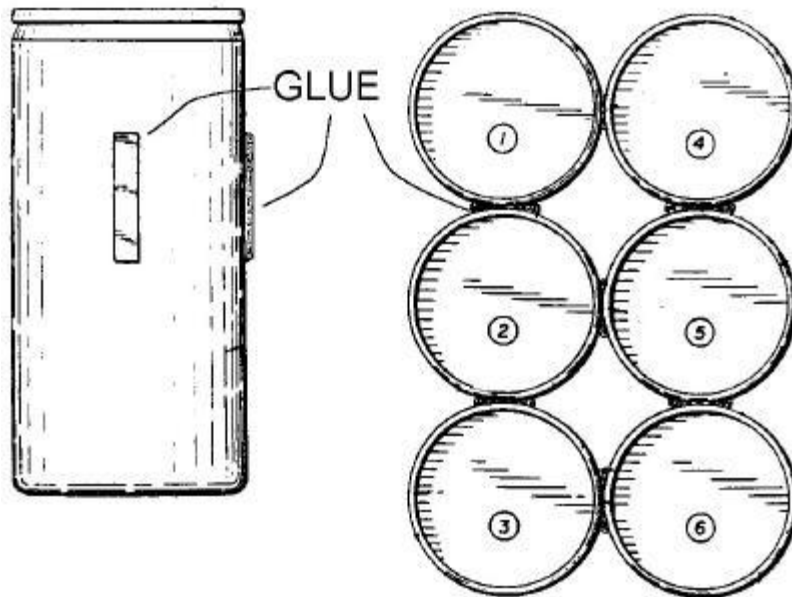
**References****Limiting references**

This place does not cover:

Separate rigid or semi-rigid trays or cups joined together by bonding, adhesive, hook and loop-type fastener or the like	B65D 21/0208
--	------------------------------

B65D 21/0206

{Separate rigid or semi-rigid trays or cups joined together, e.g. separate trays connected by single foil closure or crimped together (plurality of trays formed in one piece [B65D 1/30](#))}

Definition statement

This place covers:

Illustrative example of subject matter classified in this group:

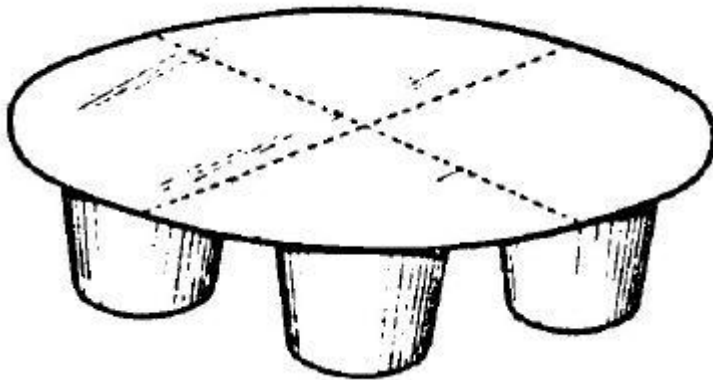

B65D 21/0208

{by bonding, adhesive, hook and loop-type fastener or the like}

Definition statement

This place covers:

Illustrative example of subject matter classified in this group:

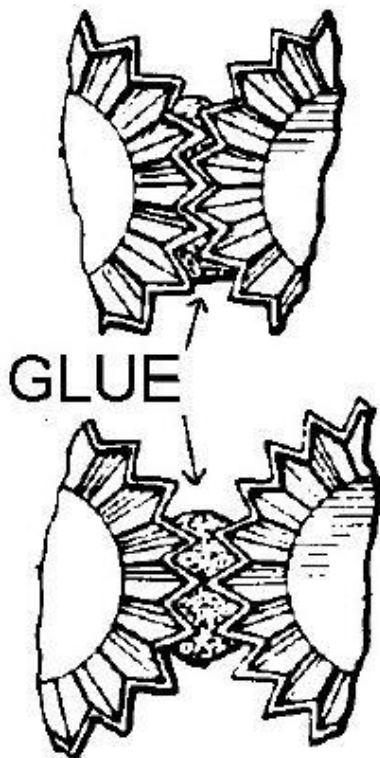
**B65D 21/0209**

{stackable or joined together one-upon-the-other in the upright or upside-down position ([B65D 21/0234](#), [B65D 21/0235](#) take precedence)}

References**Limiting references**

This place does not cover:

Nestable or stackable container parts forming a receptacle when one part is inverted upon the other	B65D 21/0234
Containers stackable in a staggered configuration	B65D 21/0235
Stackable post trays (in and out trays)	B42F 7/12

B65D 21/0211

{Wire-mesh containers}

Definition statement

This place covers:

Illustrative example of subject matter classified in this group:

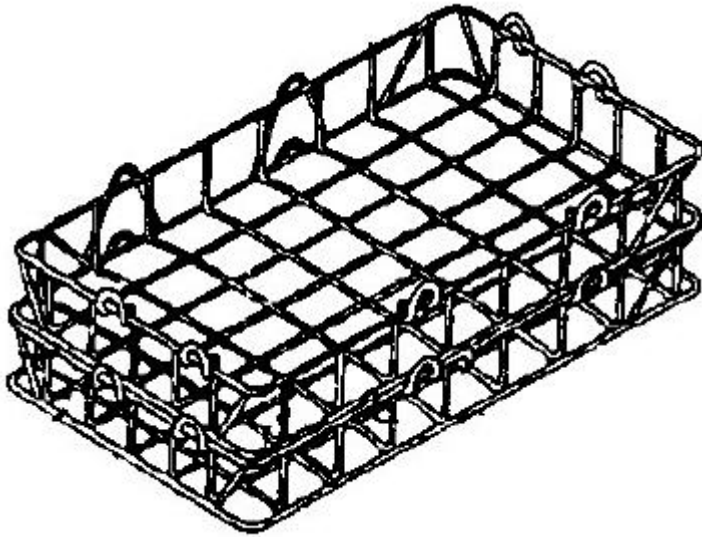

B65D 21/0212

{Containers presenting local stacking elements protruding from the upper or lower edge of a side wall, e.g. handles, lugs, ribs, grooves ([B65D 21/0211](#), [B65D 21/0215](#), [B65D 21/023](#) take precedence)}

Definition statement

This place covers:

Illustrative example of subject matter classified in this group:

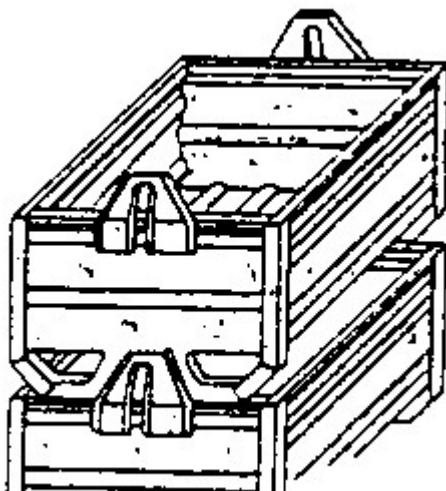

References

Limiting references

This place does not cover:

Wire-mesh containers	B65D 21/0211
Containers with stacking feet or corner elements	B65D 21/0215
Closed containers provided with local cooperating elements in the top and bottom surfaces	B65D 21/023
Stackable trays with means for draining away liquids escaping from, or exuded by, the contents	B65D 81/26

B65D 21/0213

{Containers presenting a continuous stacking profile along the upper or lower edge of at least two opposite side walls}

Definition statement

This place covers:

Illustrative example of subject matter classified in this group:

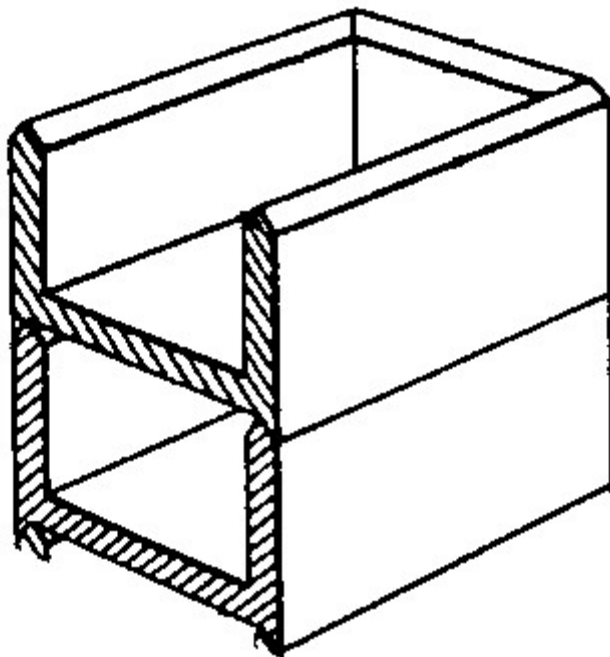

References

Limiting references

This place does not cover:

Stackable trays with means for draining away liquids escaping from, or exuded by, the contents	B65D 81/26
--	----------------------------

B65D 21/0215

{Containers with stacking feet or corner elements ([B65D 21/0211](#), [B65D 21/023](#) take precedence)}

Definition statement

This place covers:

Illustrative example of subject matter classified in this group:

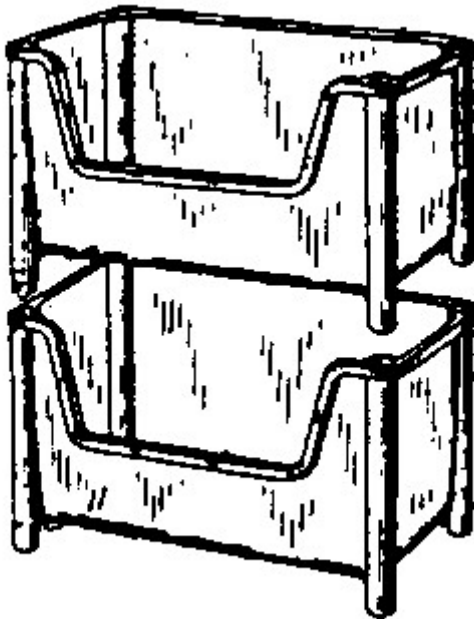
**References****Limiting references**

This place does not cover:

Wire-mesh containers	B65D 21/0211
Closed containers provided with local cooperating elements in the top and bottom surfaces	B65D 21/023
Stackable containers provided with means for draining away liquids escaping from, or exuded by, the contents	B65D 81/26

Informative references

Attention is drawn to the following places, which may be of interest for search:

Details of accessories	B65D 19/385
------------------------	-----------------------------

B65D 21/0216**{Containers with stacking ribs in the side walls}****Definition statement***This place covers:*

Illustrative example of subject matter classified in this group:

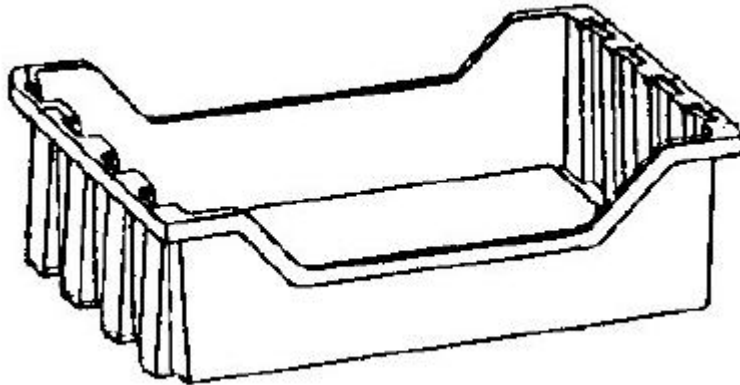
**B65D 21/0217****{Containers with a closure presenting stacking elements ([B65D 21/064](#) takes precedence)}****References****Limiting references***This place does not cover:*

Movable parts adapted to be placed in alternative positions for nesting the containers when empty and for stacking them when full, the movable parts being an attached or integral cover made of one or two pieces	B65D 21/064
--	-----------------------------

B65D 21/0219

{the closure presenting projecting peripheral elements receiving or surrounding the bottom or peripheral elements projecting from the bottom of a superimposed container ([B65D 21/0222](#) and [B65D 21/0223](#) take precedence)}

Definition statement

This place covers:

Illustrative example of subject matter classified in this group:

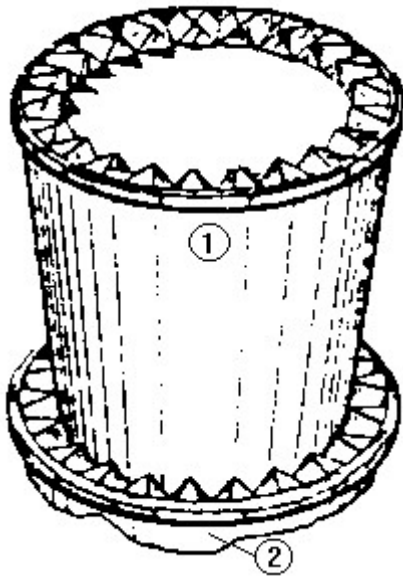
**References****Limiting references**

This place does not cover:

Containers with a closure presenting stacking elements the closure and the bottom presenting co-operating peripheral ribs and grooves	B65D 21/0222
Containers with a closure presenting stacking elements the closure and the bottom presenting local co-operating elements	B65D 21/0223

B65D 21/022

{the bottom presenting projecting peripheral elements receiving or surrounding the closure or peripheral elements projecting therefrom
([B65D 21/0222](#) and [B65D 21/0223](#) take precedence)}

Definition statement

This place covers:

Illustrative example of subject matter classified in this group:

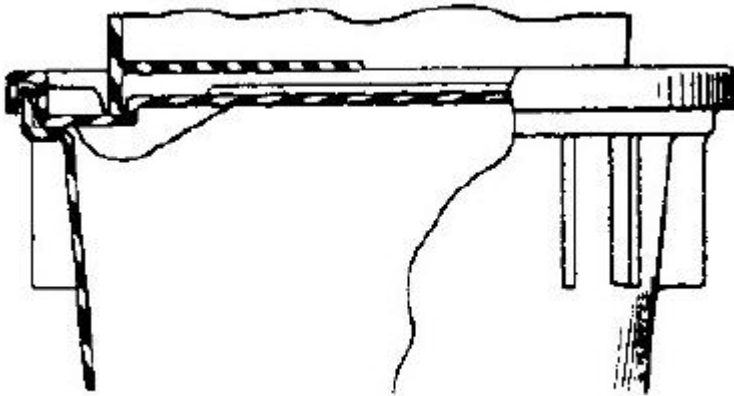
**References****Limiting references**

This place does not cover:

Containers with a closure presenting stacking elements the closure and the bottom presenting co-operating peripheral ribs and grooves	B65D 21/0222
Containers with a closure presenting stacking elements the closure and the bottom presenting local co-operating elements	B65D 21/0223

B65D 21/0222

{the closure and the bottom presenting co-operating peripheral ribs and grooves}

Definition statement

This place covers:

Illustrative example of subject matter classified in this group:

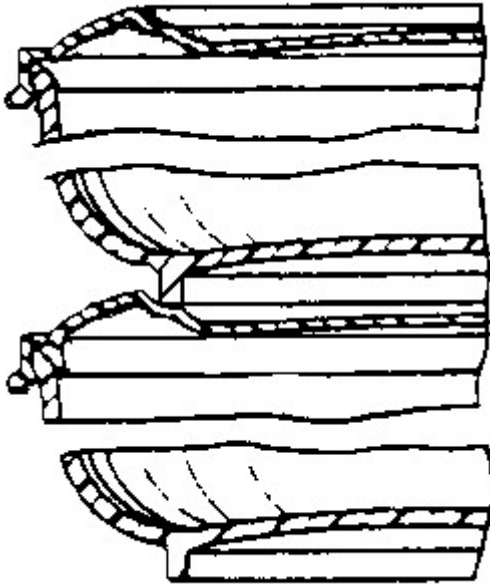

B65D 21/0223

{the closure and the bottom presenting local co-operating elements, e.g. projections and recesses ([B65D 21/0222](#) takes precedence)}

Definition statement

This place covers:

Illustrative example of subject matter classified in this group:

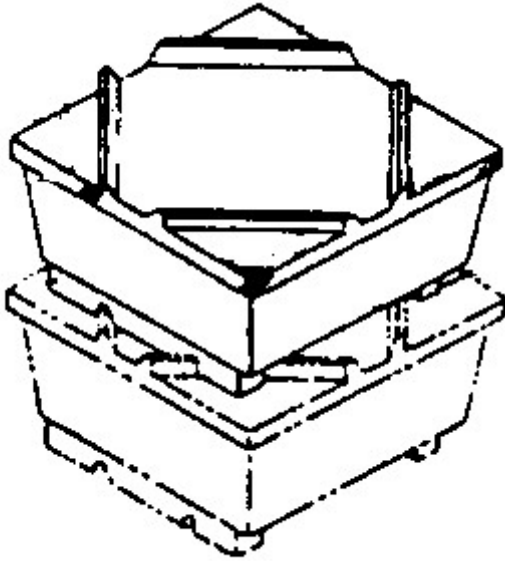
**References****Limiting references**

This place does not cover:

Containers with a closure presenting stacking elements the closure and the bottom presenting co-operating peripheral ribs and grooves	B65D 21/0222
---	------------------------------

B65D 21/0224**{Auxiliary removable stacking elements other than covers}****Definition statement***This place covers:*

Illustrative example of subject matter classified in this group:

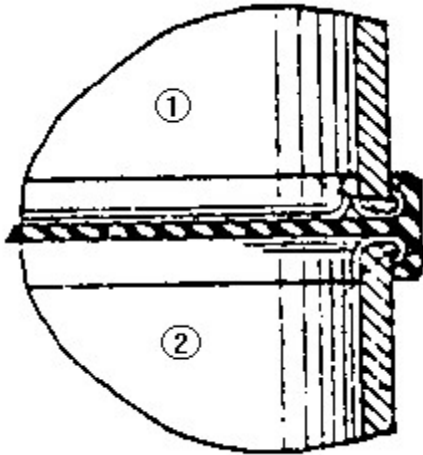
**References****Limiting references***This place does not cover:*

Auxiliary removable stacking elements in combination with the possibility for stacking containers side-by-side are also classified in	B65D 21/0201
---	------------------------------

Informative references*Attention is drawn to the following places, which may be of interest for search:*

Internal frames or supports for flexible articles	B65D 57/00
A plurality of articles held together only partially by packaging elements formed otherwise than by folding a blank, coaxial connections.	B65D 71/502
Separate rigid or semi-rigid containers joined to each other at their external surfaces	B65D 81/3205

B65D 21/0226

{Containers with movable parts adapted to be placed in alternative positions for stacking the containers at different levels, i.e. without nesting of the containers (with means for nesting [B65D 21/06](#))}

Definition statement

This place covers:

Illustrative examples of subject matter classified in this group:

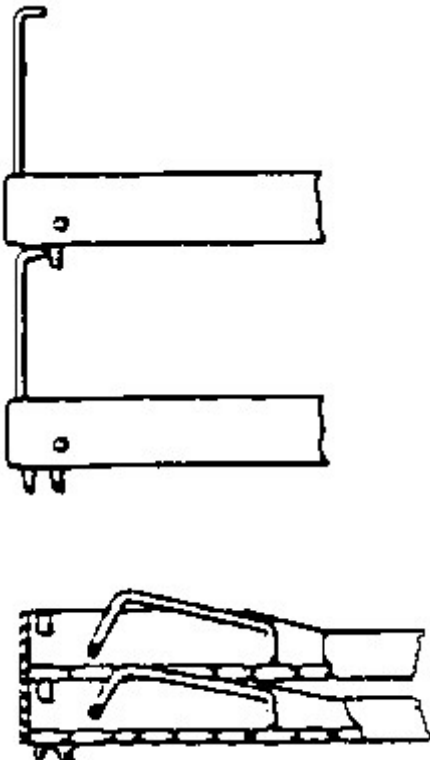
**References****Informative references**

Attention is drawn to the following places, which may be of interest for search:

Movable parts adapted to be placed in alternative positions for nesting the containers when empty and for stacking them when full, the movable parts being attached or integral and displaceable into a position overlying the top of the container	B65D 21/062
---	-----------------------------

B65D 21/0227

{Containers joined together by bonding, adhesive or the like}

Definition statement

This place covers:

Illustrative example of subject matter classified in this group:

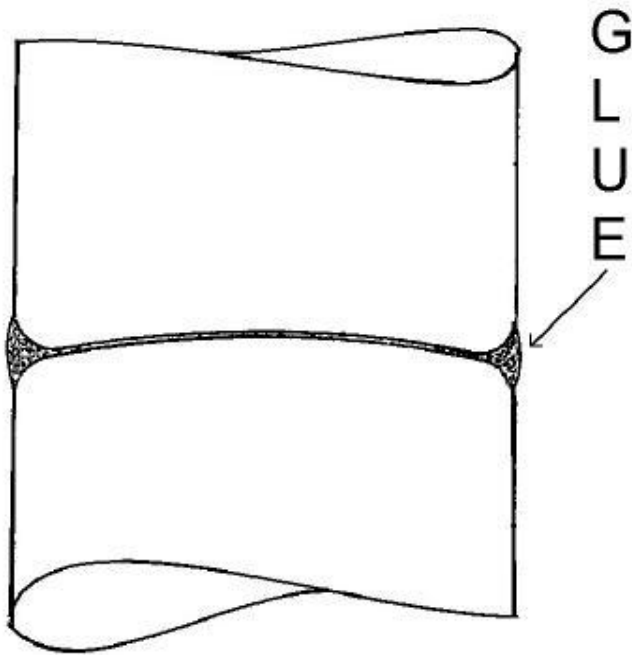

B65D 21/0228

{Containers joined together by screw-, bayonet-, snap-fit or the like, ([B65D 21/0211](#), [B65D 21/0231](#) take precedence)}

Definition statement

This place covers:

Illustrative example of subject matter classified in this group:

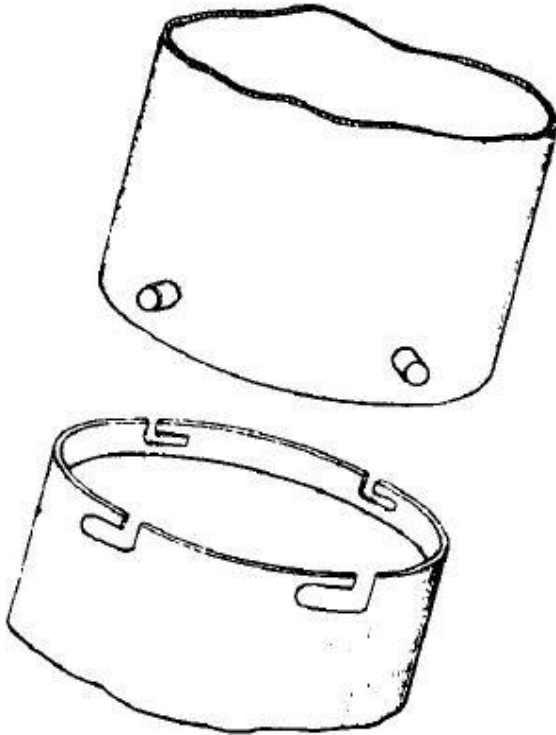
**References****Limiting references**

This place does not cover:

Wire-mesh containers	B65D 21/0211
Bottles, canisters or jars whereby the neck or handle project into a cooperating cavity in the bottom	B65D 21/0231

B65D 21/023

{Closed containers provided with local cooperating elements in the top and bottom surfaces, e.g. projection and recess ([B65D 21/0223](#) takes precedence)}

Definition statement

This place covers:

Illustrative example of subject matter classified in this group:

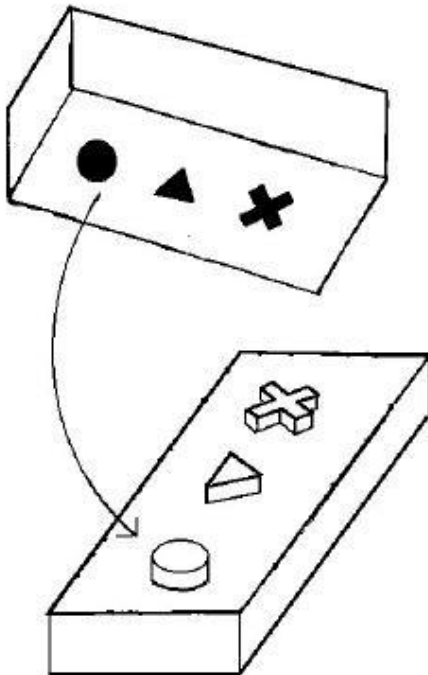
**References****Limiting references**

This place does not cover:

Containers with a closure presenting stacking elements, the closure and the bottom presenting local co-operating elements	B65D 21/0223
---	------------------------------

B65D 21/0231

{Bottles, canisters or jars whereby the neck or handle project into a cooperating cavity in the bottom ([B65D 81/361](#) takes precedence)}

Definition statement

This place covers:

Illustrative example of subject matter classified in this group:

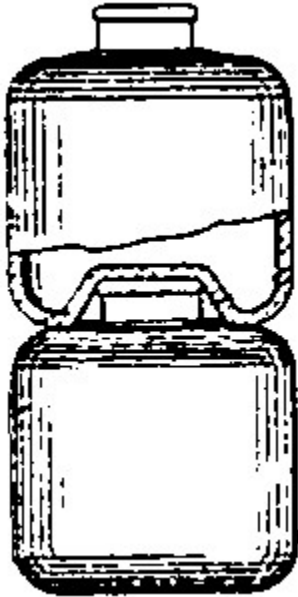

References

Limiting references

This place does not cover:

Modular elements with complementary shapes, interengageable parts or the like	B65D 81/361
---	-----------------------------

B65D 21/0233**{Nestable containers}****Definition statement***This place covers:*

Illustrative example of subject matter classified in this group:

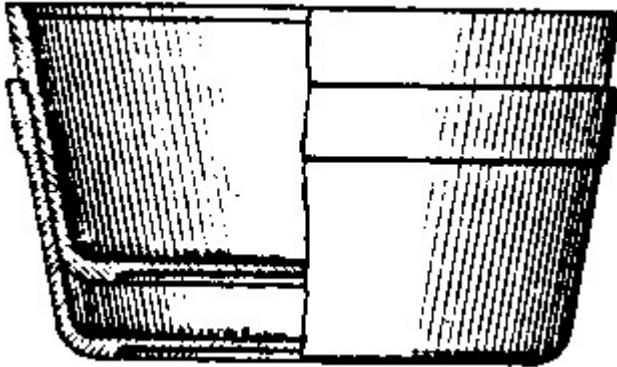
**References****Limiting references***This place does not cover:*

Nestable cups made of one piece	B65D 1/265
Nested by turning over every other container	B65D 21/0234

B65D 21/0234

{Nestable or stackable container parts forming a receptacle when one part is inverted upon the other}

Definition statement

This place covers:

Illustrative example of subject matter classified in this group:

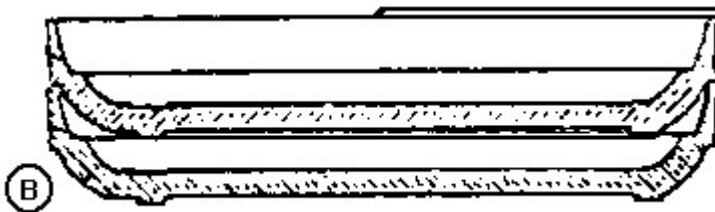
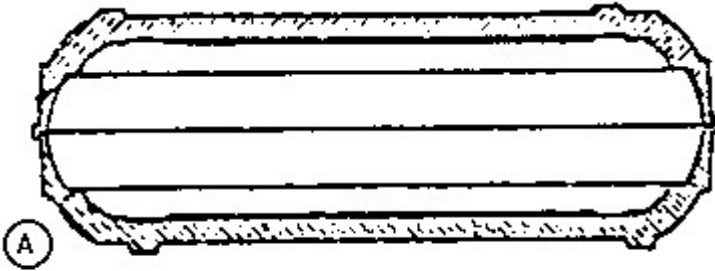
**B65D 21/0235**

{Containers stackable in a staggered configuration}

Definition statement

This place covers:

Illustrative example of subject matter classified in this group:

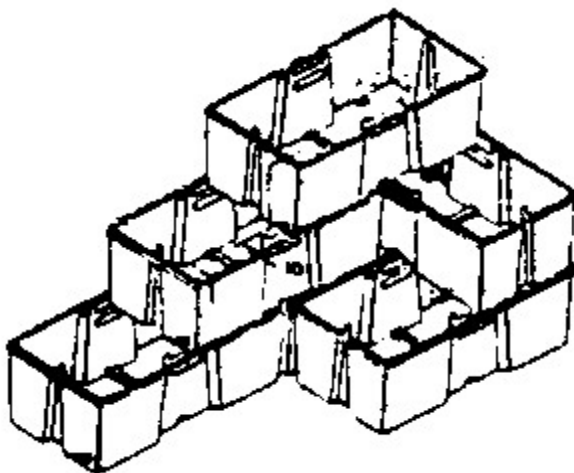

References

Informative references

Attention is drawn to the following places, which may be of interest for search:

Identical stackable containers specially adapted for nesting after rotation around a vertical axis about 90	B65D 21/046
---	-----------------------------

B65D 21/0237

{Rigid or semi-rigid containers provided with a recess on their external surface for accommodating a smaller container}

Definition statement

This place covers:

Illustrative example of subject matter classified in this group:

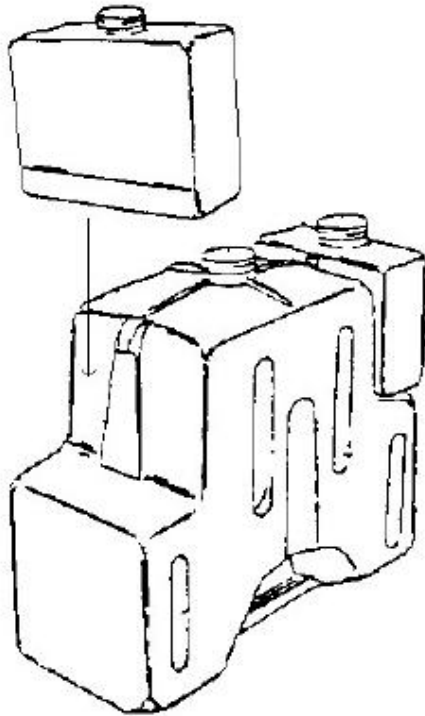

References

Informative references

Attention is drawn to the following places, which may be of interest for search:

Means for the attachment of tags	B65D 23/14
----------------------------------	----------------------------

B65D 21/0238

{Rigid or semi-rigid containers provided with a recess in order to be seated on the neck or similar protrusion of a larger container}

Definition statement

This place covers:

Illustrative example of subject matter classified in this group:

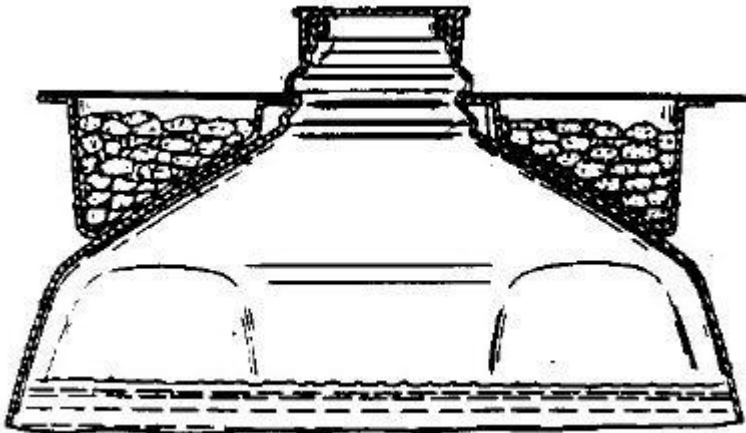
**References****Informative references**

Attention is drawn to the following places, which may be of interest for search:

Means for the attachment of tags	B65D 23/14
----------------------------------	----------------------------

B65D 21/04

Open-ended containers shaped to be nested when empty and to be superposed when full

References**Limiting references**

This place does not cover:

Nested by turning over every other container	B65D 21/0234
--	------------------------------

B65D 21/041

{Identical multi-level containers, i.e. having at least three levels}

Definition statement

This place covers:

Illustrative example of subject matter classified in this group:

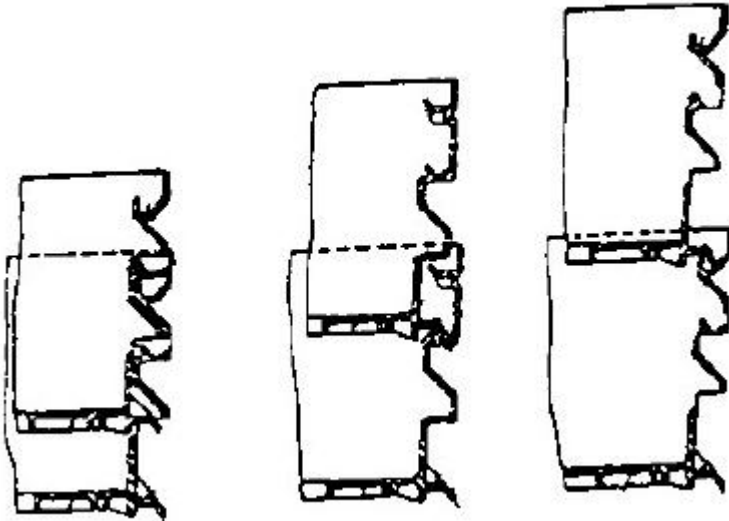
**References****Limiting references**

This place does not cover:

If all the levels are obtained by the same movable parts	B65D 21/062
--	-----------------------------

B65D 21/043

{Identical stackable containers specially adapted for nesting after rotation around a vertical axis ([B65D 21/041](#) takes precedence)}

References**Limiting references**

This place does not cover:

Identical multi-level containers	B65D 21/041
----------------------------------	-----------------------------

B65D 21/045

{about 180° only}

Definition statement

This place covers:

Illustrative example of subject matter classified in this group:

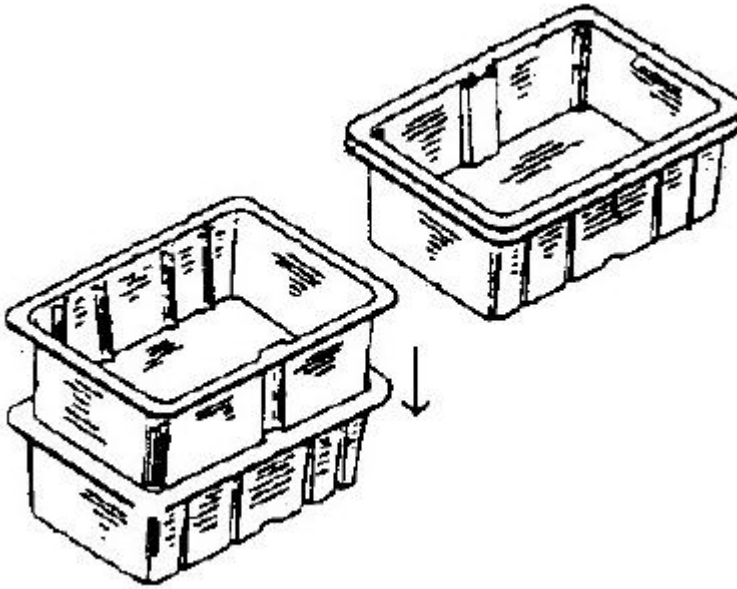

B65D 21/046

{about 90° (staggered configuration [B65D 21/0235](#))}

Definition statement

This place covers:

Illustrative example of subject matter classified in this group:

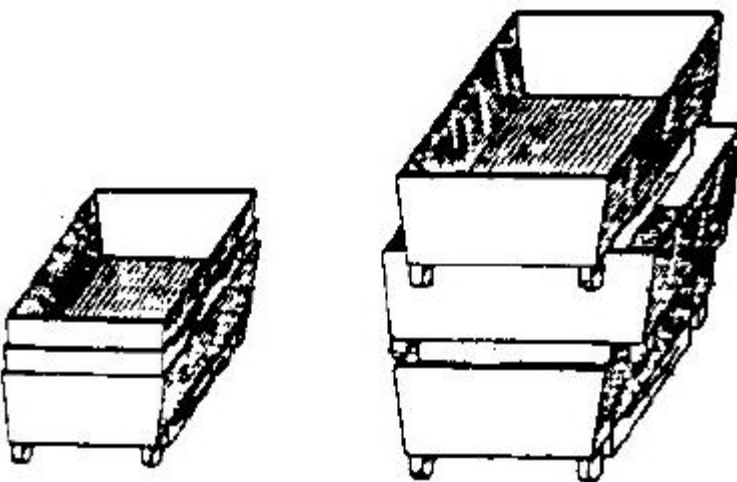

References

Informative references

Attention is drawn to the following places, which may be of interest for search:

Containers stackable in a staggered configuration	B65D 21/0235
---	------------------------------

B65D 21/048

{Identical stackable containers specially adapted for retaining the same orientation when nested, e.g. the upper container being fixed or slightly rotatable during the nesting operation ([B65D 21/041](#) takes precedence)}

Definition statement

This place covers:

Illustrative example of subject matter classified in this group:

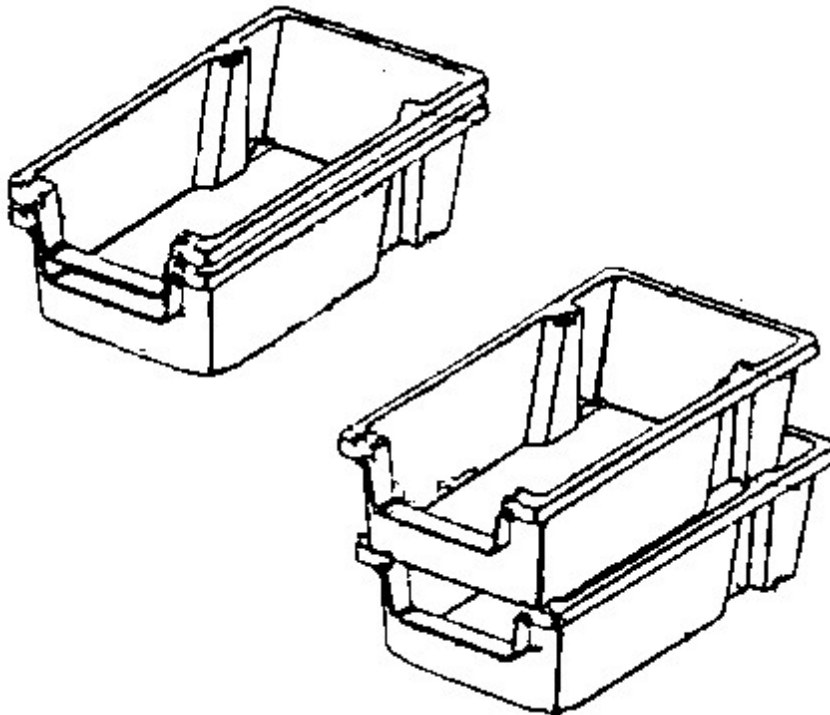

References

Limiting references

This place does not cover:

Identical multi-level containers	B65D 21/041
----------------------------------	-----------------------------

B65D 21/062

{the movable parts being attached or integral and displaceable into a position overlying the top of the container, e.g. bails, corner plates (covers [B65D 21/064](#))}

Definition statement

This place covers:

Illustrative example of subject matter classified in this group:

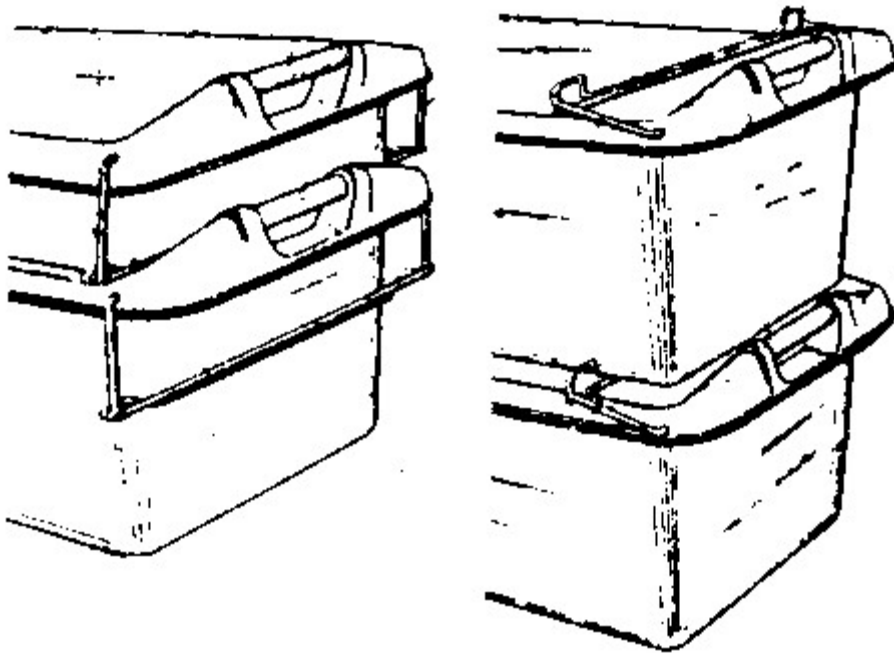
**References*****Informative references***

Attention is drawn to the following places, which may be of interest for search:

Containers with movable parts adapted to be placed in alternative positions for stacking the containers at different levels (containers not nesting)	B65D 21/0226
--	------------------------------

B65D 21/064

{the movable parts being an attached or integral cover made of one or two pieces}

Definition statement

This place covers:

Illustrative example of subject matter classified in this group:

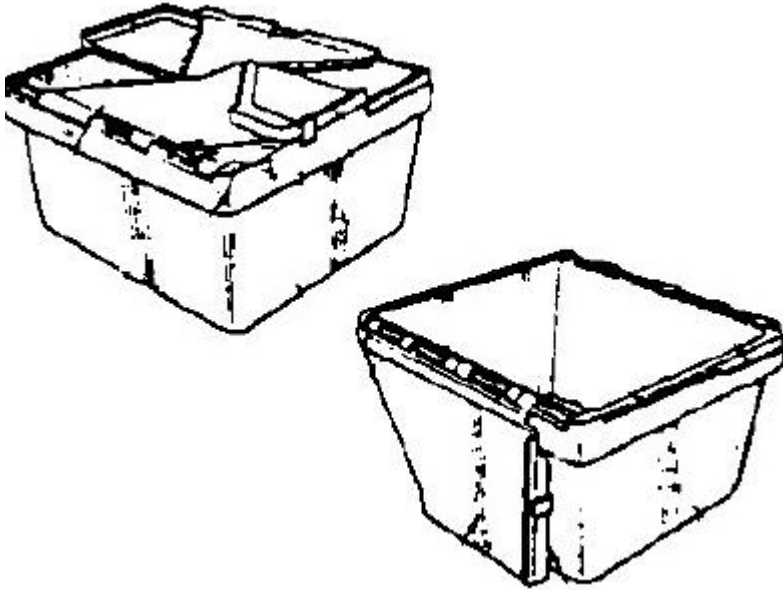

B65D 21/066

{the movable parts being supports or feet, e.g. retractable feet, pivotable supports}

Definition statement

This place covers:

Illustrative example of subject matter classified in this group:

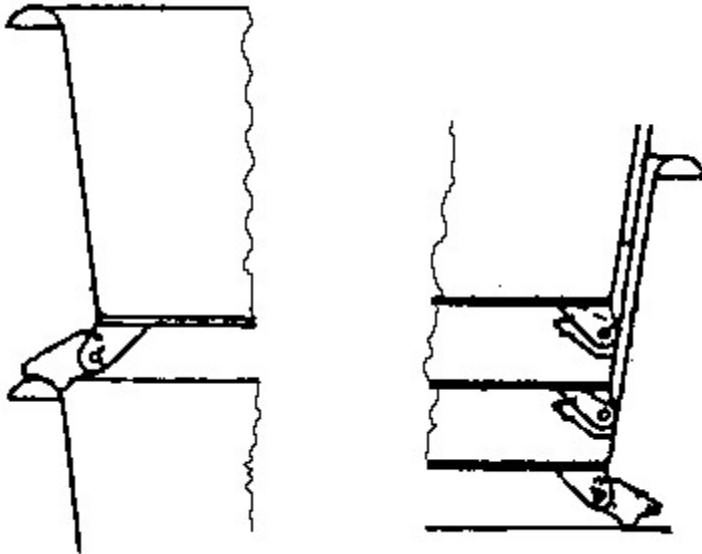
**B65D 21/068**

{the movable parts consisting of walls or parts thereof, i.e. deformable containers}

Definition statement

This place covers:

Illustrative example of subject matter classified in this group:

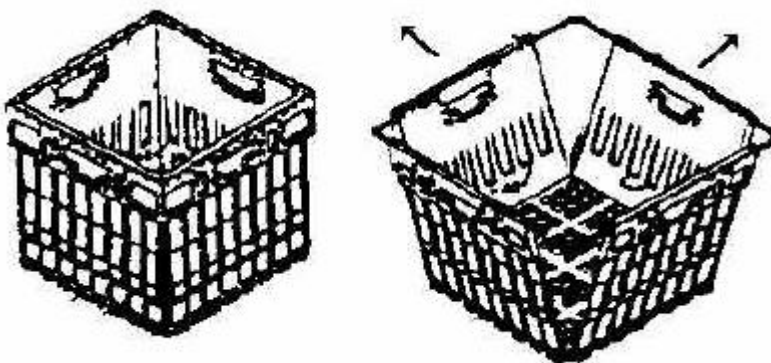

B65D 21/08

Containers of variable capacity (containers of polygonal cross-section adapted to be of variable capacity formed by folding or erecting blanks made of paper {[B65D 5/0005](#)})

References**Limiting references**

This place does not cover:

Foldable bottles	B65D 1/0292
Bottles made of several parts with variable capacity	B65D 11/04
Containers with breakable or removable sections to adapt to the remaining contents	B65D 83/0005

Informative references

Attention is drawn to the following places, which may be of interest for search:

Containers adapted to be temporarily deformed by external pressure to expel contents	B65D 1/32
Containers having bodies formed by interconnecting or uniting two or more rigid, or substantially rigid, components made wholly or mainly of wood or substitutes therefor, with double end walls and bottoms movable under influence of contents	B65D 9/28

B65D 21/083

{by means of additional elements, e.g. modular}

Definition statement

This place covers:

Illustrative example of subject matter classified in this group:

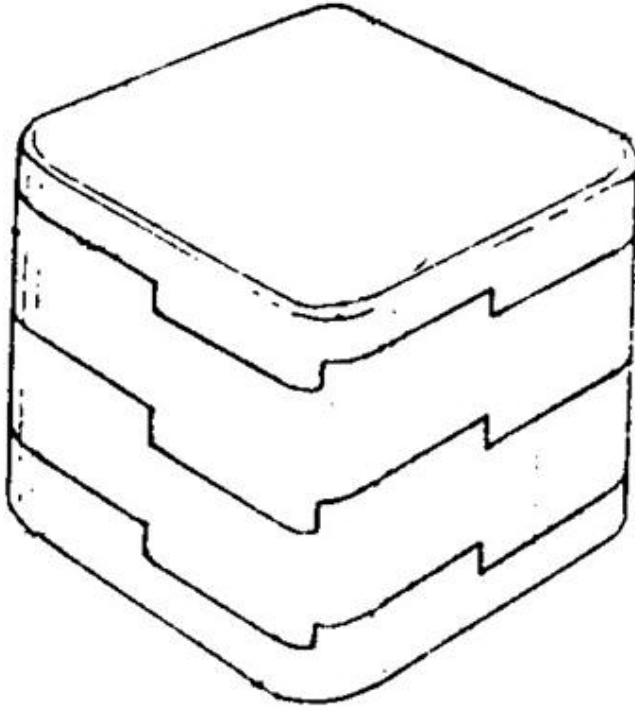

References

Informative references

Attention is drawn to the following places, which may be of interest for search:

Collapsible containers, with detachable components where all walls are detached from each other to collapse the container	B65D 11/1873
---	------------------------------

B65D 21/086

{Collapsible or telescopic containers ([B65D 1/0292](#) and [B65D 21/068](#) take precedence)}

Definition statement

This place covers:

Illustrative example of subject matter classified in this group:

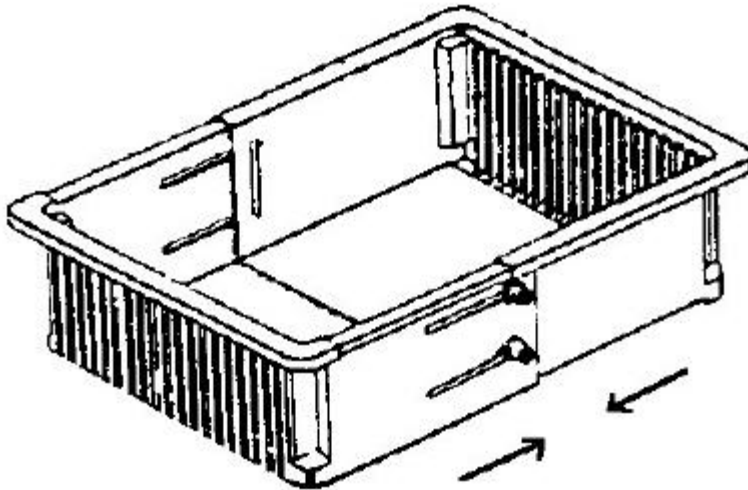
**References****Limiting references**

This place does not cover:

Foldable bottles	B65D 1/0292
Nestable, stackable, or joinable containers with movable parts where the movable parts consist of walls or parts thereof	B65D 21/068

B65D 23/00

Details of bottles or jars not otherwise provided for (closure-securing elements [B65D 45/00](#))

References**Limiting references**

This place does not cover:

Nets for bottles	B65D 29/04
Coaxial connectors, e.g. for transferring the contents from one bottle to another,	B65D 71/502
Protecting rings see also	B65D 85/307
Bottles for medical use	A61J 1/00
Containers made of glass see also	C03C

B65D 23/001

{Supporting means fixed to the container}

Definition statement

This place covers:

Illustrative example of subject matter classified in this group:

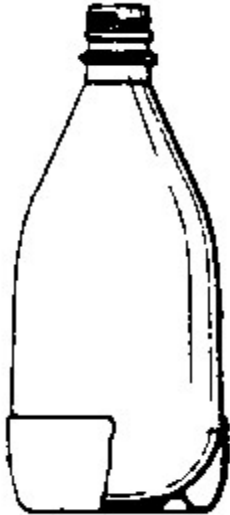

B65D 23/003

{Suspension means}

Definition statement

This place covers:

Illustrative example of subject matter classified in this group:



References

Limiting references

This place does not cover:

Suspending devices connected to the closure	B65D 51/242
---	-----------------------------

Informative references

Attention is drawn to the following places, which may be of interest for search:

Holders or handles for hanging up infusion containers	A61M 5/1417
---	-----------------------------

B65D 23/005

{in the form of a label hanger}

Definition statement

This place covers:

Illustrative example of subject matter classified in this group:

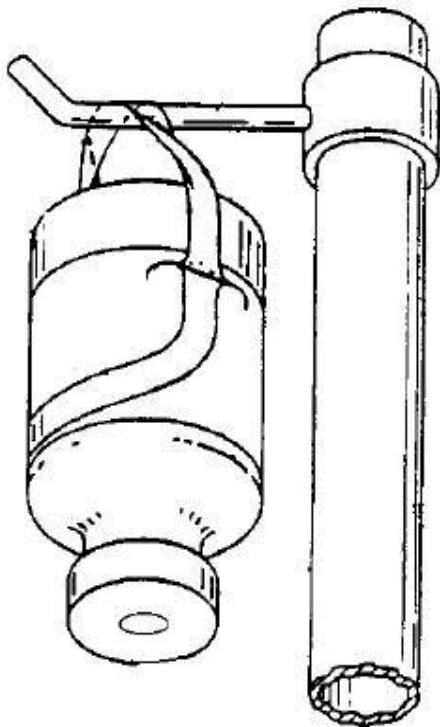

B65D 23/006

{Means for indicating refilling of the container}

Definition statement

This place covers:

Illustrative example of subject matter classified in this group:

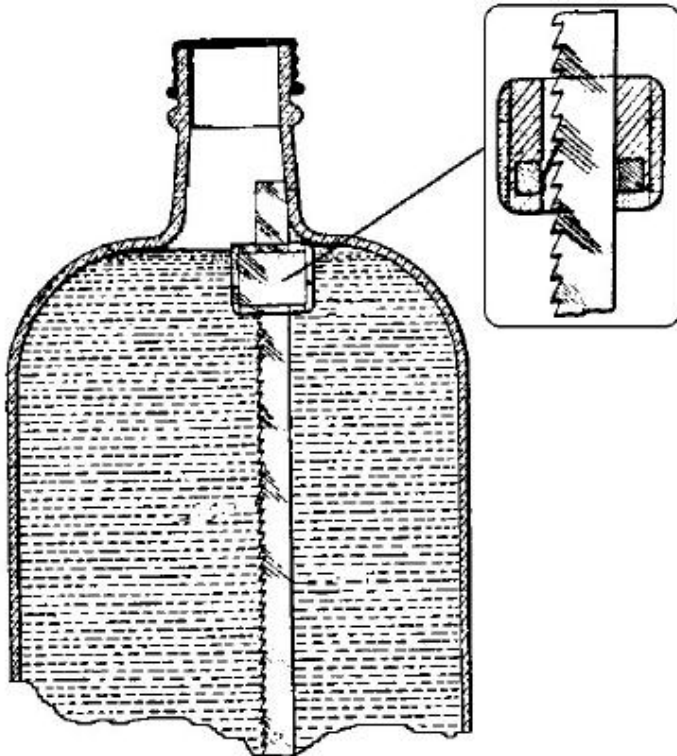

B65D 23/008

{by means of a label, e.g. tearable, light sensitive}

Definition statement

This place covers:

Illustrative example of subject matter classified in this group:

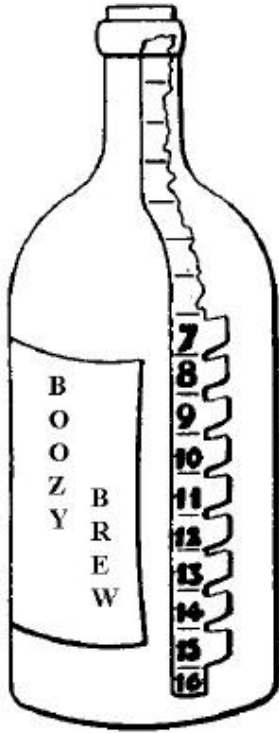

B65D 23/02**Linings or internal coatings****Definition statement**

This place covers:

Illustrative example of subject matter classified in this group:

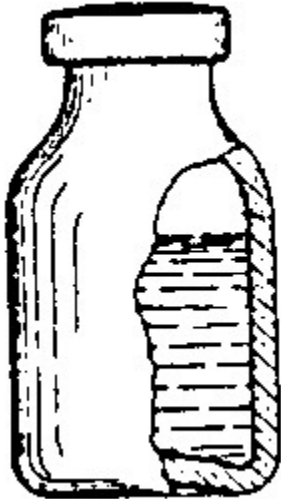
**References****Informative references**

Attention is drawn to the following places, which may be of interest for search:

Bottles or similar containers with necks or like restricted apertures, designed for pouring contents, characterised by material and multilayered	B65D 1/0215
Linings or internal coatings	B65D 25/14

B65D 23/04

Means for mixing or for promoting flow of contents (hydro-dynamic means for influencing the flow of liquids [F15D](#))

Definition statement

This place covers:

Illustrative example of subject matter classified in this group:

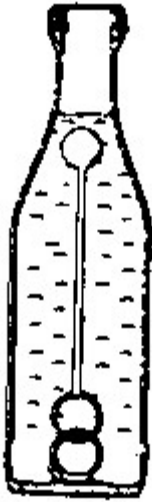
**References****Limiting references**

This place does not cover:

Stirring devices	B01F 33/00
------------------	----------------------------

Informative references

Attention is drawn to the following places, which may be of interest for search:

Hydrodynamic means for influencing the flow of liquids	F15D 1/00
--	---------------------------

B65D 23/06**Integral drip catchers or drip-preventing means****Definition statement**

This place covers:

Illustrative example of subject matter classified in this group:

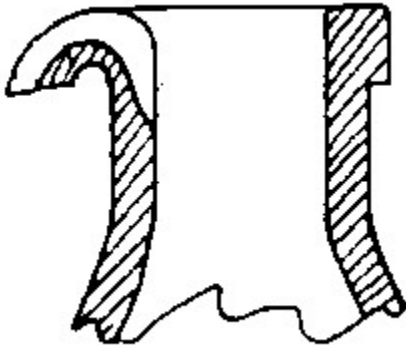
**References****Informative references**

Attention is drawn to the following places, which may be of interest for search:

Closures with filling and discharging, or with discharging, devices with drip catchers or drip-preventing means	B65D 47/40
---	----------------------------

B65D 23/065**{Loose or loosely-attached drip catchers or drip preventing means}****Definition statement***This place covers:*

Illustrative example of subject matter classified in this group:

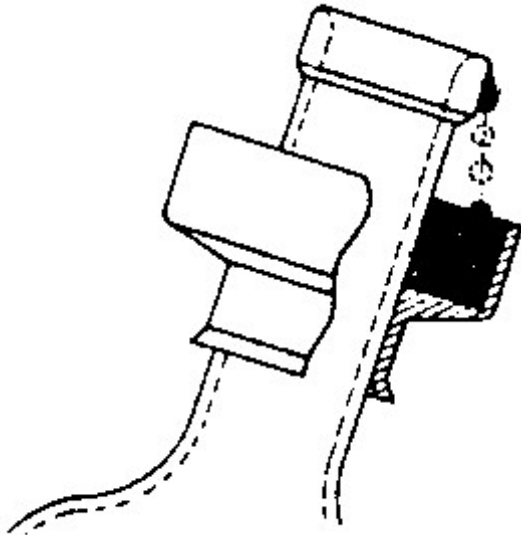
**References****Informative references***Attention is drawn to the following places, which may be of interest for search:*

Closures with filling and discharging, or with discharging, devices with drip catchers or drip-preventing means	B65D 47/40
---	----------------------------

B65D 23/08**Coverings or external coatings (wrappers [B65D 65/00](#))****References****Limiting references***This place does not cover:*

Protecting nets	B65D 29/04
Wrappers with shock-absorbing properties	B65D 81/03

Informative references*Attention is drawn to the following places, which may be of interest for search:*

Wrappers	B65D 65/00
----------	----------------------------

B65D 23/0807**{Coatings}****Definition statement***This place covers:*

Illustrative example of subject matter classified in this group:

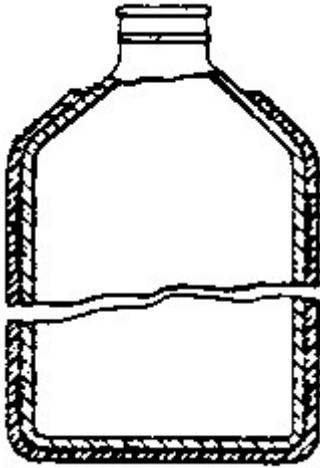
**B65D 23/0821****{consisting mainly of polymeric materials ([B65D 23/0828](#) takes precedence)}****References*****Limiting references****This place does not cover:*

Coatings consisting mainly of paints or lacquers	B65D 23/0828
--	------------------------------

B65D 23/085

{and glued or otherwise sealed to the bottle ([B65D 23/0857](#), [B65D 23/0864](#), [B65D 23/0871](#) take precedence)}

Definition statement

This place covers:

Illustrative example of subject matter classified in this group:

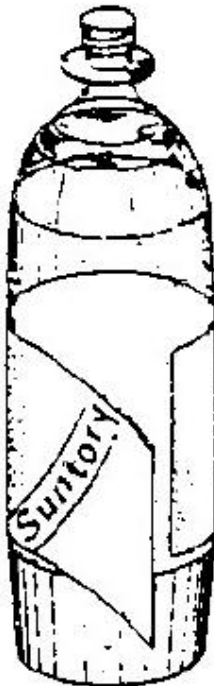
**References****Limiting references**

This place does not cover:

Sheets or tubes applied around the bottle and locked to the bottle by mechanical means	B65D 23/0857
Sheets or tubes applied around the bottle, applied in mould	B65D 23/0864
Sheets or tubes applied around the bottle, stretched over the bottle	B65D 23/0871

B65D 23/0857

{and locked to the bottle by mechanical means, e.g. tabs snapping into recesses of the bottle ([B65D 23/0871](#), [B65D 23/0878](#) take precedence)}

Definition statement

This place covers:

Illustrative example of subject matter classified in this group:

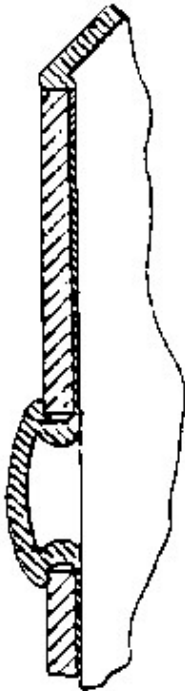
**References****Limiting references**

This place does not cover:

Sheets or tubes applied around the bottle, stretched over the bottle	B65D 23/0871
Sheets or tubes applied around the bottle, shrunk on the bottle	B65D 23/0878

B65D 23/0864**{Applied in mould}****Definition statement***This place covers:*

Illustrative example of subject matter classified in this group:

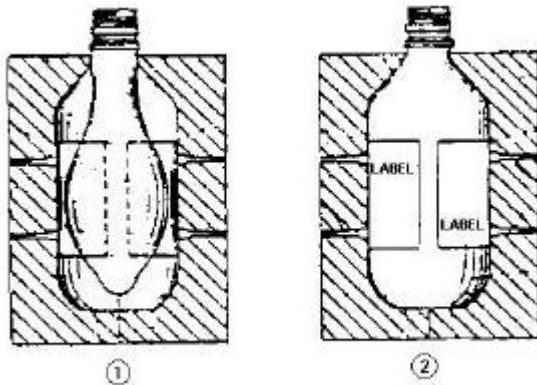
**References****Limiting references***This place does not cover:*

Methods or machines for in-mould labelling	B29C 49/2408
--	------------------------------

B65D 23/0871**{Stretched over the bottle ([B65D 23/0892](#) takes precedence)}****References****Limiting references***This place does not cover:*

Net-like covers	B65D 23/0892
For other containers	B65D 25/36
Stretched films as packages	B65D 75/006
Labels to be fastened or secured by the material of the label itself, e.g. by thermo-adhesion	G09F 3/04

B65D 23/0878**{Shrunk on the bottle}****Definition statement***This place covers:*

Illustrative example of subject matter classified in this group:

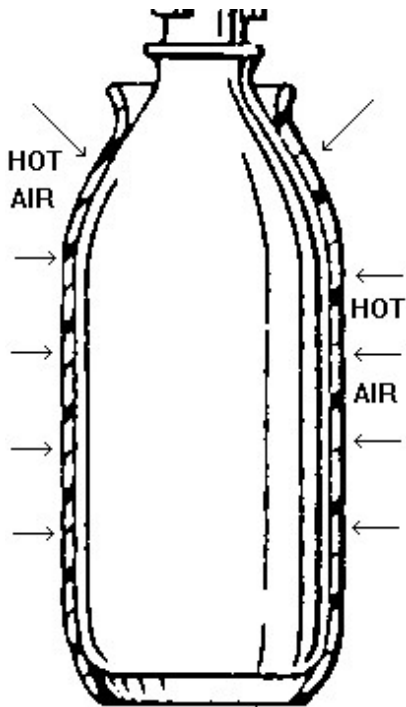
**References****Limiting references***This place does not cover:*

For other containers	B65D 25/36
Shrunk films as packages	B65D 75/002
Labels to be fastened or secured by the material of the label itself, e.g. by thermo-adhesion	G09F 3/04

B65D 23/0885

{Rigid shells for receiving the bottle or part of it ([B65D 23/0842](#), [B65D 81/3876](#), [B65D 85/302](#) take precedence)}

Definition statement

This place covers:

Illustrative example of subject matter classified in this group:

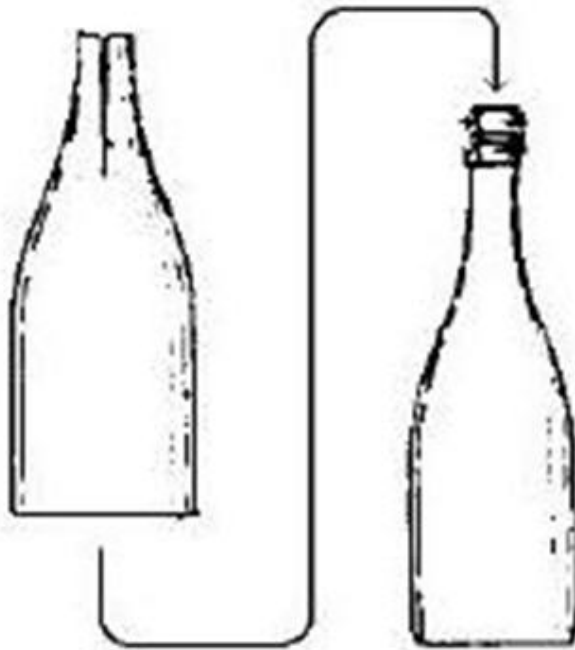
**References****Limiting references**

This place does not cover:

Sleeves	B65D 23/0842
Not specially adapted for bottles	B65D 77/04
Insulating sleeves or jackets for cans, bottles, barrels, etc.	B65D 81/3876
For carboys	B65D 85/302

B65D 23/0892

{Net-like covers}

Definition statement

This place covers:

Illustrative example of subject matter classified in this group:



B65D 23/10

Handles

Definition statement

This place covers:

Illustrative example of subject matter classified in this group:



References

Limiting references

This place does not cover:

Suspension means	B65D 23/003
------------------	-----------------------------

B65D 23/102**{Gripping means formed in the walls, e.g. roughening, cavities, projections}****Definition statement***This place covers:*

Illustrative example of subject matter classified in this group:

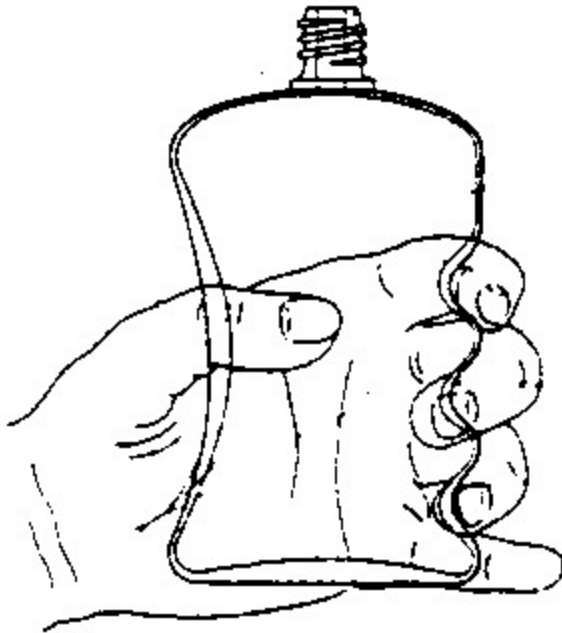
**References****Limiting references***This place does not cover:*

Roughening in a plastic box	B65D 1/40
For feeding bottles	A61J 9/00

B65D 23/104**{Handles formed separately}****References****Limiting references***This place does not cover:*

Holders for feeding-bottles	A61J 9/06
-----------------------------	---------------------------

Informative references*Attention is drawn to the following places, which may be of interest for search:*

Handles for carrying purposes	A45F 5/10
-------------------------------	---------------------------

B65D 23/106

{the gripping region of the handle extending between the neck and the base of the bottle or jar and being located in a radial plane comprising the axis of the bottle or jar}

Definition statement

This place covers:

Illustrative example of subject matter classified in this group:

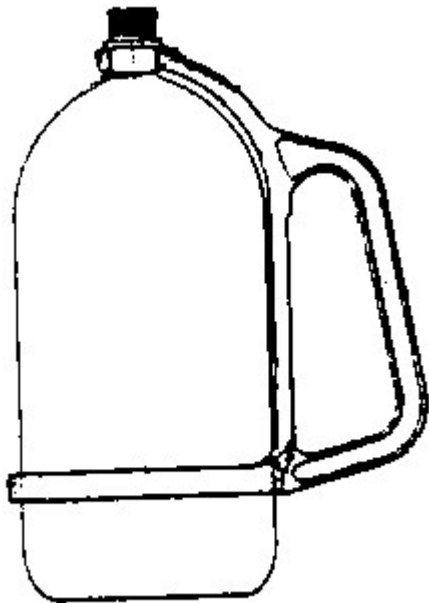

References

Informative references

Attention is drawn to the following places, which may be of interest for search:

Glass or bottle holders for decanters	A47G 23/0241
---------------------------------------	------------------------------

B65D 23/108

{Bail handles, i.e. pivoted handles of generally semi-circular or loop shape}

Definition statement

This place covers:

Illustrative example of subject matter classified in this group:

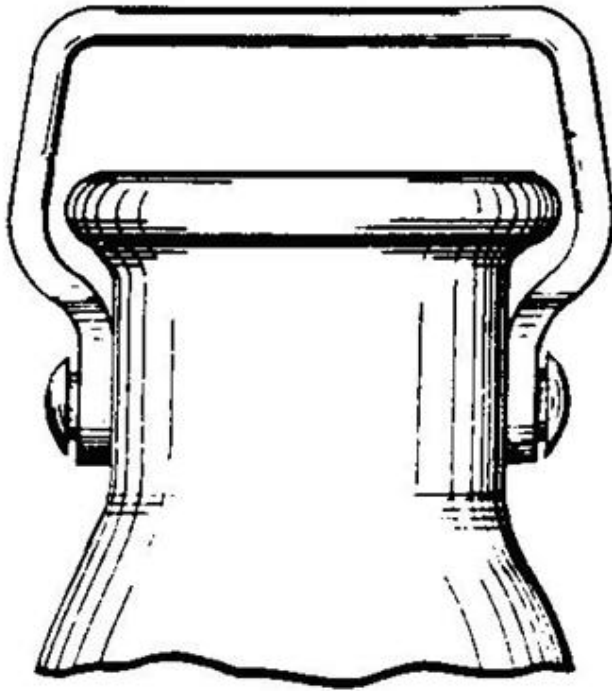
**References*****Informative references***

Attention is drawn to the following places, which may be of interest for search:

Hand holes, bail handles	B65D 25/32
--------------------------	----------------------------

B65D 23/14

of tags {, labels, cards, coupons, decorations or the like ([B65D 23/008](#) takes precedence)}

Definition statement

This place covers:

Illustrative example of subject matter classified in this group:

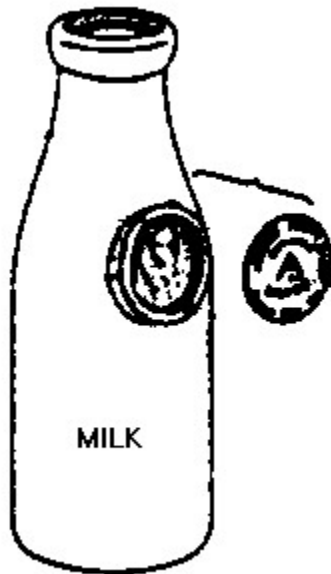
**References****Limiting references**

This place does not cover:

Means for indicating refilling of the container by means of a label	B65D 23/008
---	-----------------------------

Informative references

Attention is drawn to the following places, which may be of interest for search:

Information or decoration elements	B65D 5/4212
Means for the attachment of labels, cards, coupons or the like	B65D 25/205
Information or decoration elements	B65D 33/004
Cards, coupons, or other inserts or accessories, the inserts or accessories being located within a pouch or envelope attached to the exterior of the packages	B65D 75/545
Labels	B65D 2203/02
Labels for bottles, flasks	G09F 2003/0273

B65D 23/16

of thermometers (feeding bottles with thermometers [A61J 9/02](#))

Definition statement

This place covers:

Illustrative example of subject matter classified in this group:

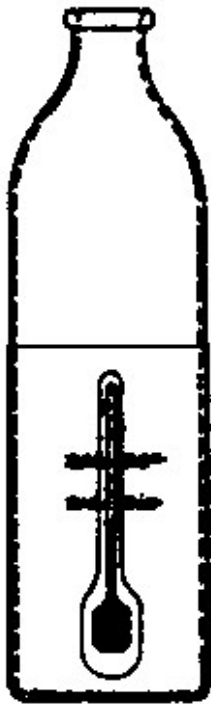
**References****Application-oriented references**

Examples of places where the subject matter of this place is covered when specially adapted, used for a particular purpose, or incorporated in a larger system:

Feeding bottles with thermometers	A61J 9/02
-----------------------------------	---------------------------

B65D 25/00

Details of other kinds or types of rigid or semi-rigid containers

References**Informative references**

Attention is drawn to the following places, which may be of interest for search:

For pallets	B65D 19/38
Of large containers	B65D 90/00

B65D 25/005

{Side walls formed with an aperture or a movable portion arranged to allow removal or insertion of contents ([B65D 5/16](#), [B65D 7/40](#) take precedence)}

Definition statement

This place covers:

Illustrative example of subject matter classified in this group:

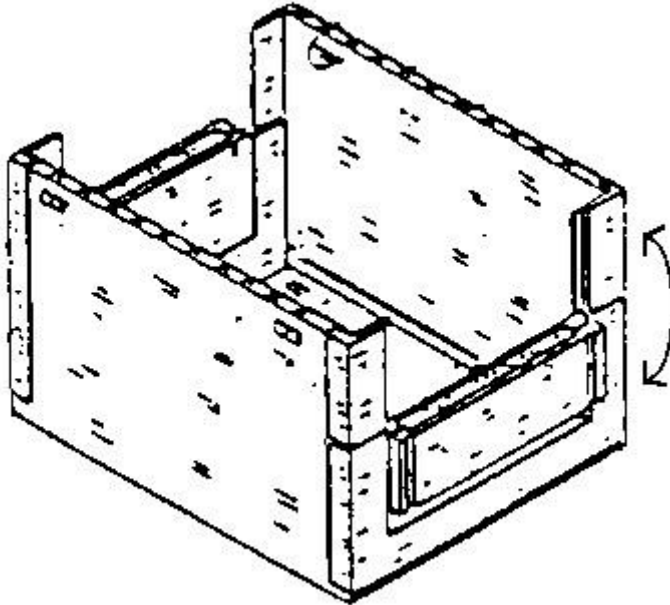
**References****Limiting references**

This place does not cover:

Tubular body being formed with an aperture or removable portion arranged to allow removal or insertion of contents through one or more sides	B65D 5/16
Walls formed with filling or emptying apertures	B65D 7/40

Informative references

Attention is drawn to the following places, which may be of interest for search:

Inspection openings or windows	B65D 25/54
--------------------------------	----------------------------

B65D 25/02

Internal fittings (of containers made by folding or erecting blanks made of paper [B65D 5/44](#))

References**Limiting references**

This place does not cover:

Of containers made by folding or erecting blanks made of paper	B65D 5/44
Means for effervescing the contents upon opening the container, e.g. bubbles in beer	B65D 25/02
Floating covers	B65D 81/245 , B65D 83/0005 , B65D 25/06

B65D 25/04**Partitions****Definition statement**

This place covers:

Illustrative example of subject matter classified in this group:

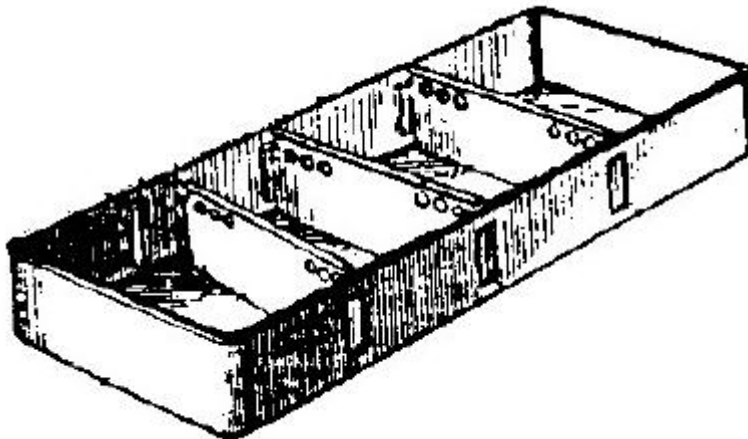
**References****Limiting references**

This place does not cover:

Boxes or like containers with moulded compartments or partitions	B65D 1/24
Made of carton	B65D 5/48
Bottle-crates	B65D 85/305

Informative references

Attention is drawn to the following places, which may be of interest for search:

Refuse receptacles being divided in compartments by partitions	B65F 1/004
--	----------------------------

B65D 25/06

adapted to be fitted in two or more alternative positions

Definition statement

This place covers:

Illustrative example of subject matter classified in this group:

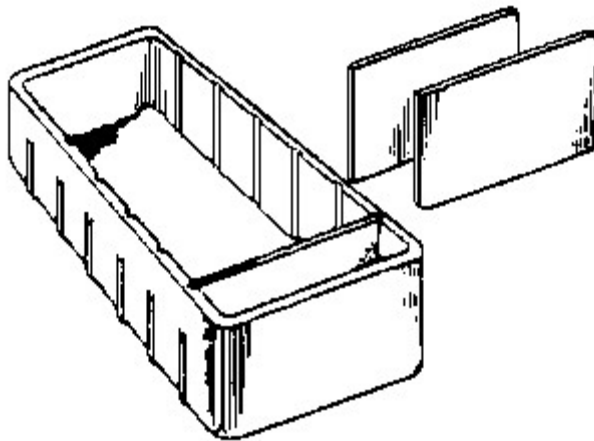
**References****Limiting references**

This place does not cover:

Floating covers	B65D 81/245 , B65D 83/0005 , B65D 25/02
-----------------	---

Informative references

Attention is drawn to the following places, which may be of interest for search:

Refuse receptacles being divided in compartments by movable partitions	B65F 1/0046
--	-----------------------------

B65D 25/08

with provisions for removing or destroying, e.g. to facilitate mixing of contents

References**Limiting references**

This place does not cover:

Separate rigid or semi-rigid containers joined to each other or disposed within the other	B65D 81/3205 , B65D 81/3216
---	--

Informative references

Attention is drawn to the following places, which may be of interest for search:

The closure presenting means for placing the additional articles or materials in contact with the main contents by acting on a part of the closure without removing the closure	B65D 51/2807
---	------------------------------

B65D 25/082

{the partition being in the form of a plug or the like which is removed by increasing or decreasing the pressure within the container ([B65D 81/3211](#) takes precedence)}

Definition statement

This place covers:

Illustrative example of subject matter classified in this group:

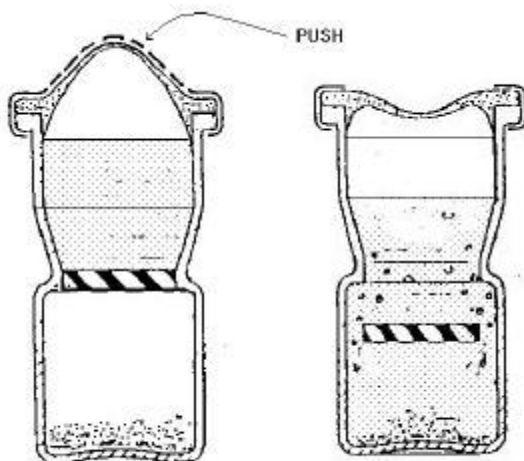
**References****Limiting references**

This place does not cover:

Separate rigid or semi-rigid containers joined to each other at their external surfaces coaxially and provided with means facilitating admixture	B65D 81/3211
--	------------------------------

Informative references

Attention is drawn to the following places, which may be of interest for search:

Containers specially adapted for medical or pharmaceutical purposes	A61J
---	----------------------

B65D 25/085

{the partition being in the form of a plug or the like which is dislodged by means of a plunger rod or the like pushing the plug down ([B65D 81/3211](#) takes precedence)}

Definition statement

This place covers:

Illustrative example of subject matter classified in this group:

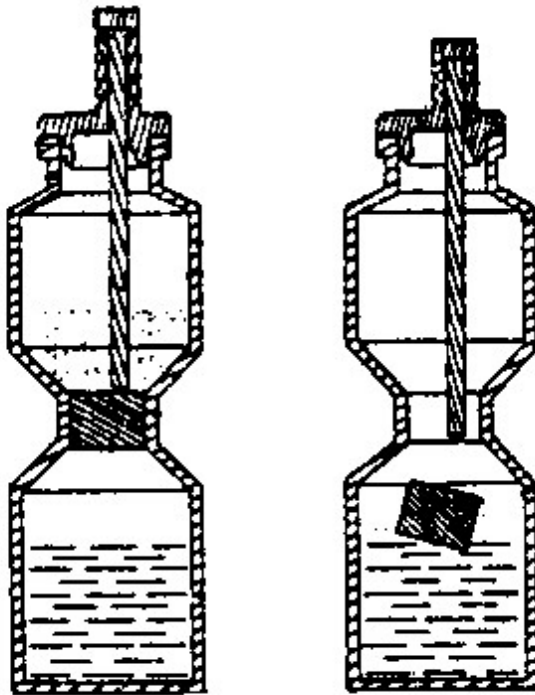
**References****Limiting references**

This place does not cover:

Separate rigid or semi-rigid containers joined to each other at their external surfaces coaxially and provided with means facilitating admixture	B65D 81/3211
--	------------------------------

B65D 25/087

{the partition being in the form of a plug or the like which can be raised off its seat by means of a pull cord or the like, e.g. the plug being connected to the cap ([B65D 81/3211](#) takes precedence)}

Definition statement

This place covers:

Illustrative example of subject matter classified in this group:

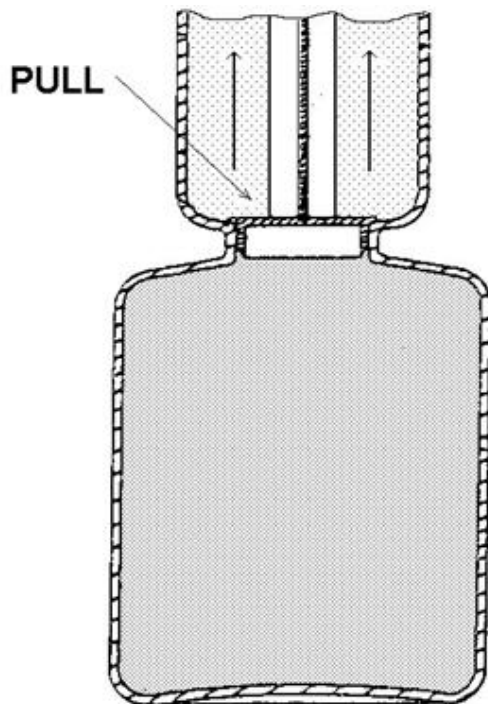
**References****Limiting references**

This place does not cover:

Separate rigid or semi-rigid containers joined to each other at their external surfaces coaxially and provided with means facilitating admixture	B65D 81/3211
--	------------------------------

B65D 25/10

Devices to locate articles in containers {(for protecting articles from mechanical damage [B65D 81/02](#))}

References**Limiting references**

This place does not cover:

Glass sheets	B65D 85/48
Bulky articles	B65D 85/64

Machines, engines, vehicles	B65D 85/68
Needles	A41H 19/00
Pencils	A45C 11/34
Drills	B25H 3/003
Tools	B25H 3/02
Record carriers	G11B 33/04
Printed circuit boards	H05K 13/0069

Informative references

Attention is drawn to the following places, which may be of interest for search:

Elements formed separately from the container body	B65D 5/5028
Elements or devices for locating or protecting articles	B65D 77/26
Maintaining contents at spaced relation from package walls, or from other contents using blocks of shock-absorbing material of a shape specially adapted to accommodate contents	B65D 81/133

B65D 25/101

{Springs, elastic lips, or other resilient elements to locate the articles by pressure ([B65D 25/102](#), [B65D 25/103](#) take precedence)}

Definition statement

This place covers:

Illustrative example of subject matter classified in this group:

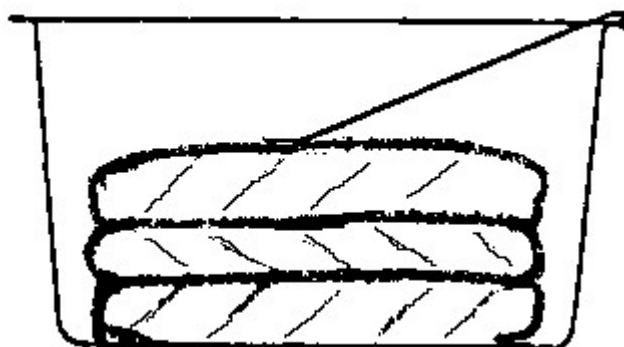

References

Limiting references

This place does not cover:

Straps, bands, strings or other elongate elements	B65D 25/102
V-shaped elements	B65D 25/103

B65D 25/102

{Straps, bands, strings or other elongate elements}

Definition statement

This place covers:

Illustrative example of subject matter classified in this group:

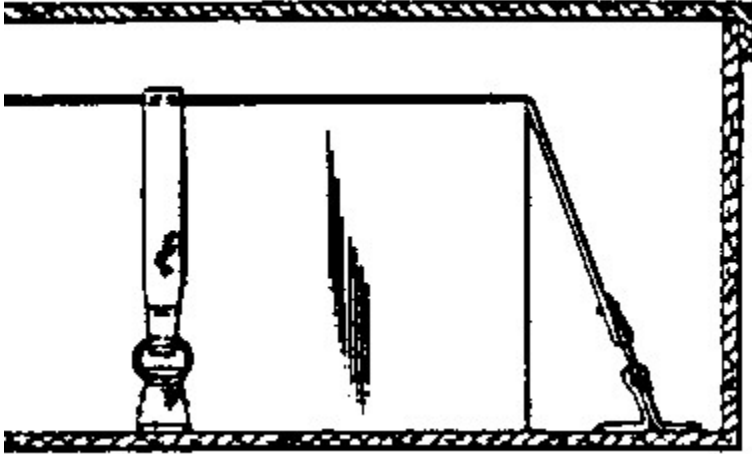

B65D 25/103

{V-shaped elements, e.g. racks, protuberances projecting from a supporting surface, supporting the articles locally at its sides ([B65D 25/107](#) takes precedence)}

Definition statement

This place covers:

Illustrative example of subject matter classified in this group:

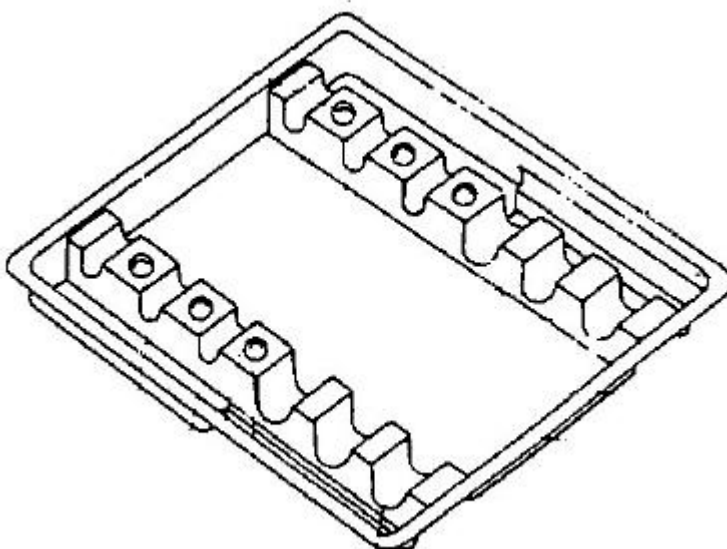

References

Limiting references

This place does not cover:

Grooves, ribs, or the like, situated on opposed walls and between which the articles are located	B65D 25/107
--	-----------------------------

Informative references

Attention is drawn to the following places, which may be of interest for search:

Maintaining contents at spaced relation from package walls, or from other contents using blocks of shock-absorbing material of a shape specially adapted to accommodate contents	B65D 81/133
--	-----------------------------

B65D 25/105

{and retaining it by snap-action, e.g. clips}

Definition statement

This place covers:

Illustrative example of subject matter classified in this group:

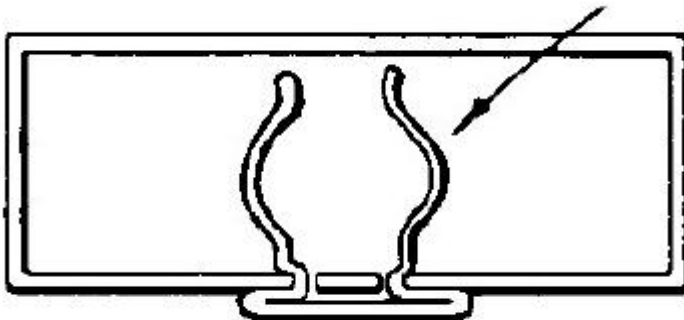

References

Limiting references

This place does not cover:

Releasable fastenings clips	F16B 2/20
-----------------------------	---------------------------

B65D 25/106

{Elements projecting into a recess or through a hole in the articles}

Definition statement

This place covers:

Illustrative example of subject matter classified in this group:

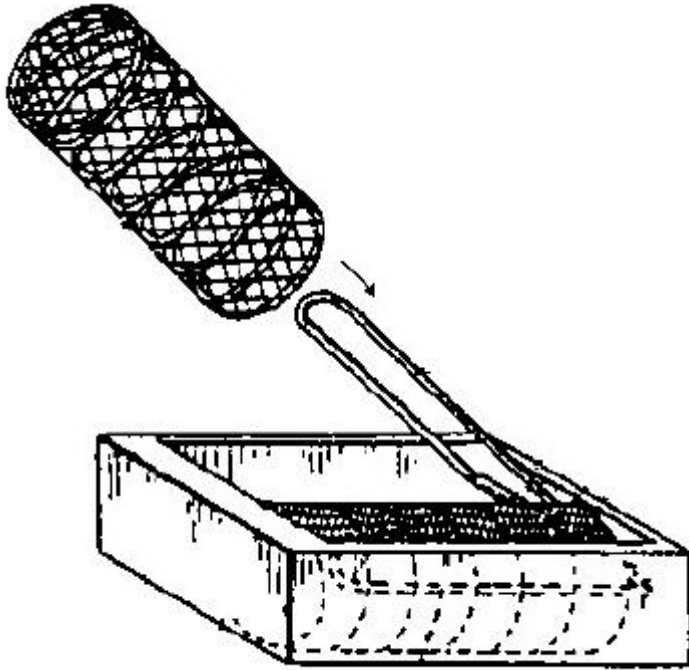

B65D 25/107

{Grooves, ribs, or the like, situated on opposed walls and between which the articles are located}

Definition statement

This place covers:

Illustrative example of subject matter classified in this group:

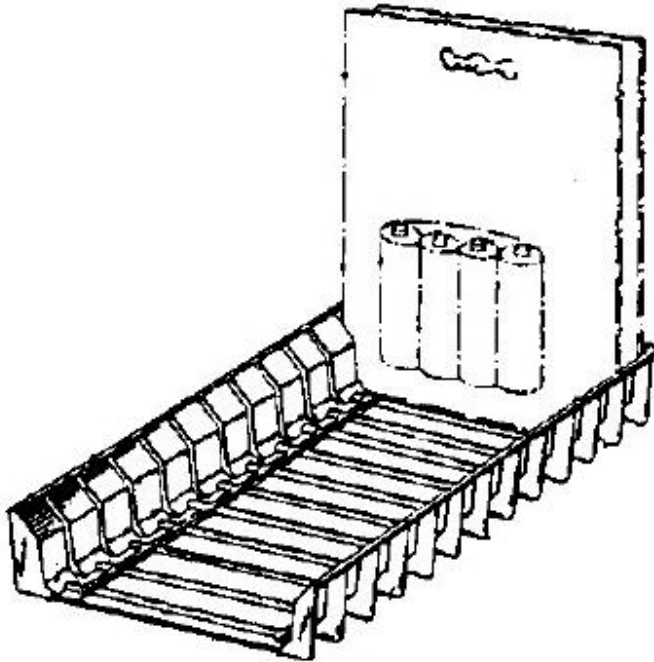

References

Informative references

Attention is drawn to the following places, which may be of interest for search:

Maintaining contents at spaced relation from package walls, or from other contents using blocks of shock-absorbing material of a shape specially adapted to accommodate contents	B65D 81/133
--	-----------------------------

B65D 25/108

{Devices, e.g. plates, presenting apertures through which the articles project}

Definition statement

This place covers:

Illustrative example of subject matter classified in this group:

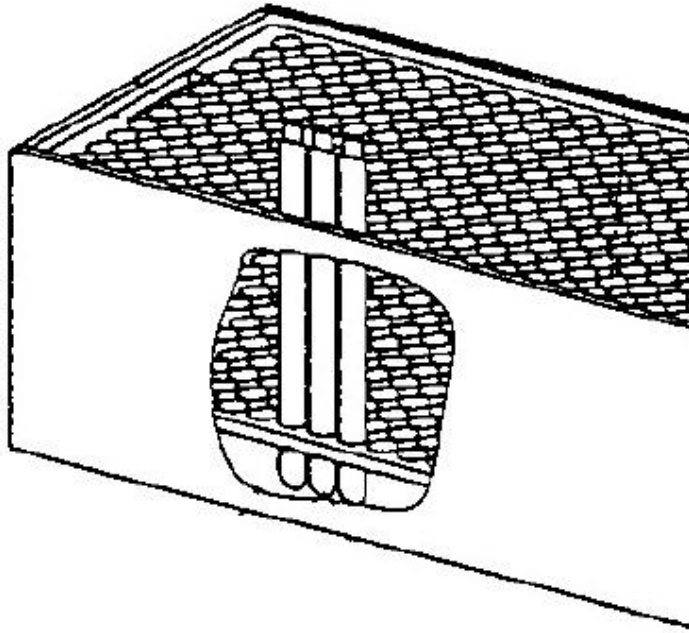

References

Informative references

Attention is drawn to the following places, which may be of interest for search:

Tray-like elements formed by folding a blank and presenting openings or recesses
--

B65D 5/5038

B65D 25/14

Linings or internal coatings (of containers made by folding or erecting blanks made of paper [B65D 5/56](#) {; linings for domestic water storage heaters [F24H 1/183](#)})

Definition statement

This place covers:

Illustrative example of subject matter classified in this group:

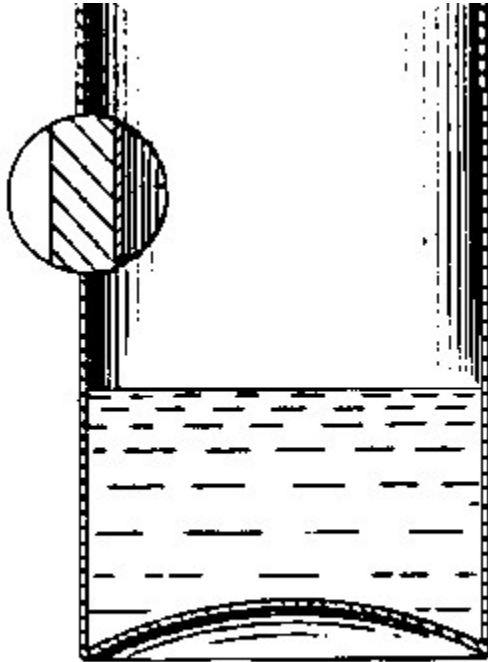

B65D 25/16**Loose, or loosely-attached, linings****Definition statement**

This place covers:

Illustrative example of subject matter classified in this group:

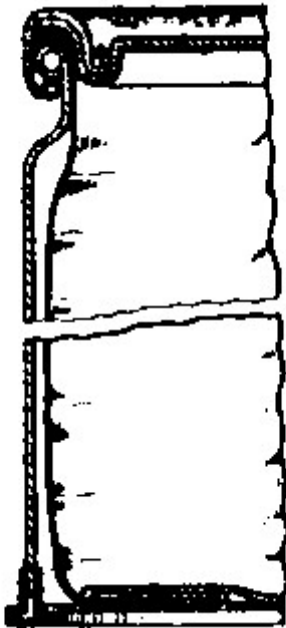
**References*****Limiting references***

This place does not cover:

Sack holders, i.e. stands or frames with means for supporting sacks in the open condition to facilitate filling with articles or materials	B65B 67/12
--	----------------------------

Special rules of classification

The use of available Indexing Codes is mandatory.

B65D 25/18

spaced appreciably from container wall

Definition statement

This place covers:

Illustrative example of subject matter classified in this group:

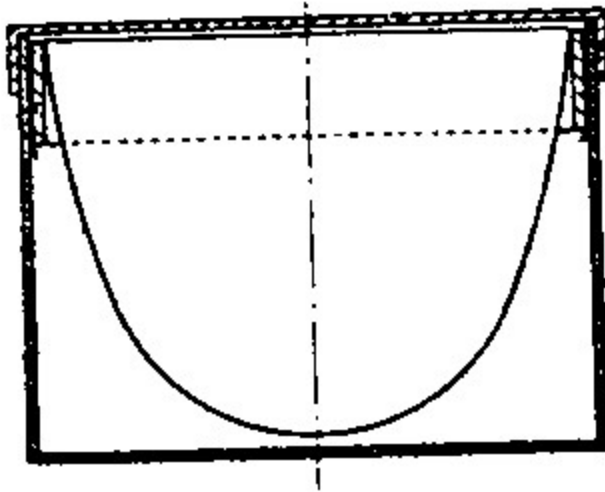

B65D 25/205

{Means for the attachment of labels, cards, coupons or the like; (cards or coupons for the other types of rigid or semi-rigid containers [B65D 25/36](#) takes precedence)}

Definition statement

This place covers:

Illustrative example of subject matter classified in this group:

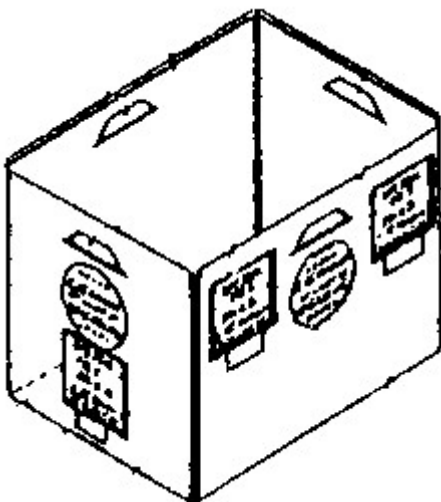

References

Limiting references

This place does not cover:

Labels or the like for bottles	B65D 23/14
Coverings or extra coatings formed by applying sheet material	B65D 25/36
Lids with labels	B65D 51/245
Shipping mailers	B65D 75/545

Informative references

Attention is drawn to the following places, which may be of interest for search:

Information on decoration elements, e.g. content indicators, or for mailing	B65D 5/4212
Information on decoration elements, e.g. level indicators, detachable pads or coupons	B65D 33/004
The inserts or accessories being located within a pouch or envelope attached to the exterior of the packages, e.g. shipping mailers	B65D 75/545

Special rules of classification

The use of available Indexing Codes is mandatory.

B65D 25/22

for facilitating lifting or suspending of containers

Definition statement

This place covers:

Illustrative example of subject matter classified in this group:

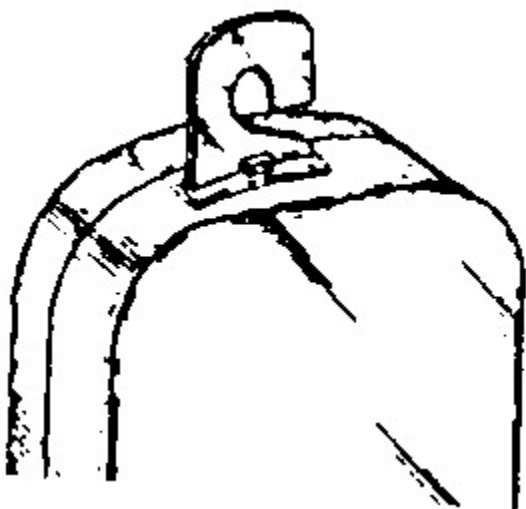

References

Limiting references

This place does not cover:

Closures provided with means for facilitating lifting or suspending of the container	B65D 51/242
Devices for transporting bundles from above, e.g. by cranes	B65D 2571/00098
Pen-like pill containers with pocket-clip	B65D 2583/045

Informative references

Attention is drawn to the following places, which may be of interest for search:

Means facilitating suspending, lifting, handling, or the like of containers	B65D 5/4208
Handles or other suspension means	B65D 75/56

Special rules of classification

The use of available Indexing Codes is mandatory.

B65D 25/24

for spacing bases of containers from supporting surfaces, e.g. legs (for pallets [B65D 19/40](#))

Definition statement

This place covers:

Illustrative example of subject matter classified in this group:

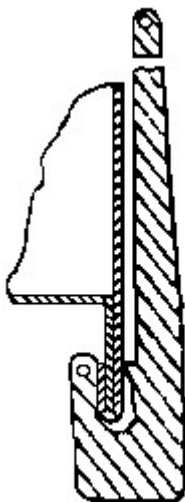

References

Limiting references

This place does not cover:

Isolated supports for palletisable loads (isolated feet)	B65D 71/0088
Isolated supports for palletisable loads (isolated skids)	B65D 71/0092
For large containers	B65D 90/12

B65D 25/28

Handles (of containers made by folding or erecting blanks made of paper [B65D 5/46](#); of bottles or jars [B65D 23/10](#) {; holders for glasses, bottles, cartons, plastic bags, cans [A47G 23/02](#)})

References

Limiting references

This place does not cover:

Handles for carrying holders, or carriers for hand articles	A45F 5/10
---	---------------------------

Special rules of classification

The use of available Indexing Codes is mandatory.

B65D 25/2802

{fixed, i.e. non-swingable, handles ([B65D 25/2867](#), [B65D 25/2882](#) take precedence)}

References

Limiting references

This place does not cover:

With respective ends fixed to local areas of two opposite sides or wall-part	B65D 25/2867
Integral handles	B65D 25/2882

Special rules of classification

The use of available Indexing Codes is mandatory.

B65D 25/2805

{provided on a local area of the side walls}

Special rules of classification

The use of available Indexing Codes is mandatory.

B65D 25/2808

{Horizontal, e.g. U-shaped}

Definition statement

This place covers:

Illustrative example of subject matter classified in this group:

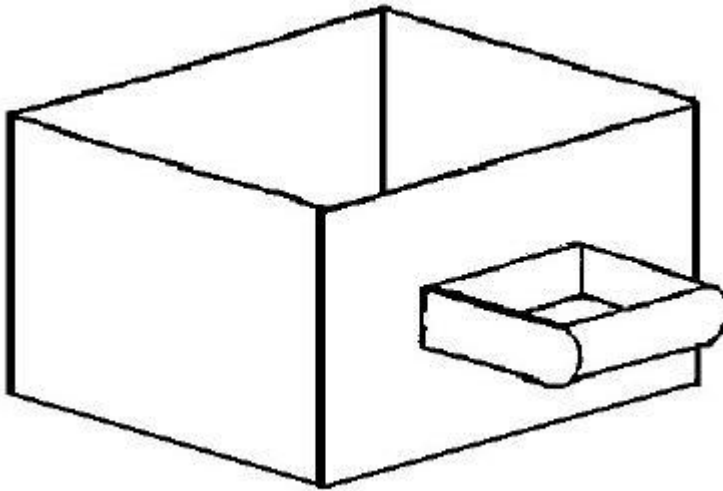

Special rules of classification

The use of available Indexing Codes is mandatory.

B65D 25/2811

{Vertical, e.g. U-shaped}

Definition statement

This place covers:

Illustrative example of subject matter classified in this group:

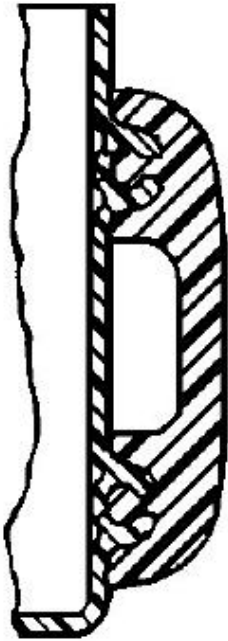

Special rules of classification

The use of available Indexing Codes is mandatory.

B65D 25/2814

{as a part or combined with a label or wrapping sheet or tube}

Definition statement

This place covers:

Illustrative example of subject matter classified in this group:

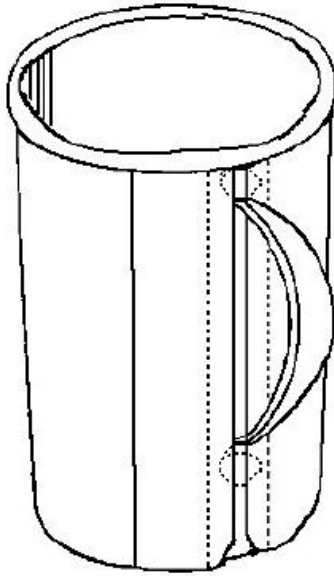

Special rules of classification

The use of available Indexing Codes is mandatory.

B65D 25/2817

{fixed by means of one or more collars}

Definition statement

This place covers:

Illustrative example of subject matter classified in this group:

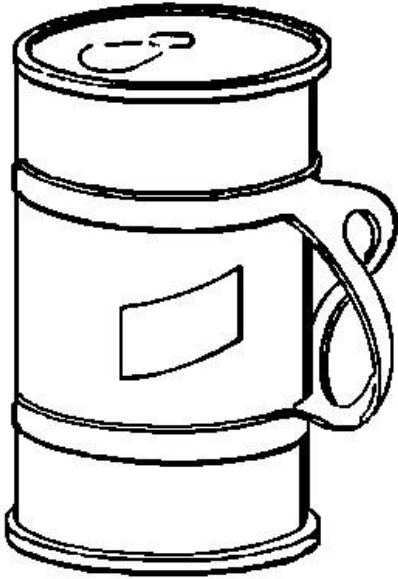

Special rules of classification

The use of available Indexing Codes is mandatory.

B65D 25/282

{provided on a local area near to or at the upper edge or rim}

Definition statement

This place covers:

Illustrative example of subject matter classified in this group:

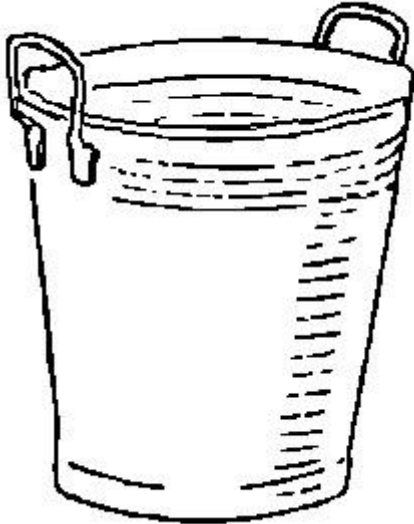

Special rules of classification

The use of available Indexing Codes is mandatory.

B65D 25/2823

{centrally located in open container}

Definition statement

This place covers:

Illustrative example of subject matter classified in this group:

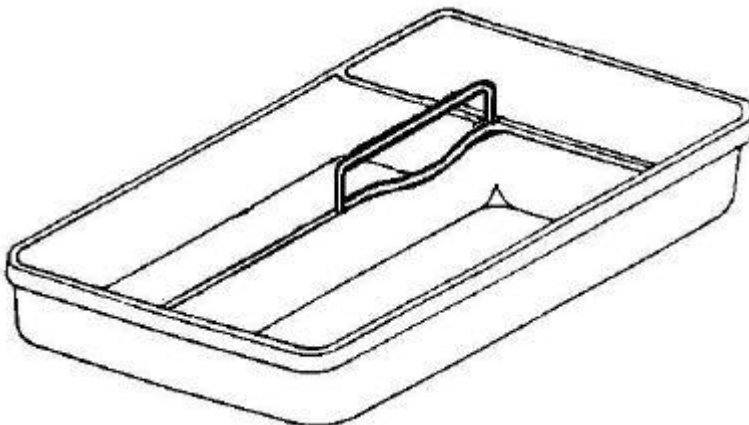

Special rules of classification

The use of available Indexing Codes is mandatory.

B65D 25/2826

{provided on a local area of the upper (top) wall, e.g. U-shaped}

Definition statement

This place covers:

Illustrative example of subject matter classified in this group:

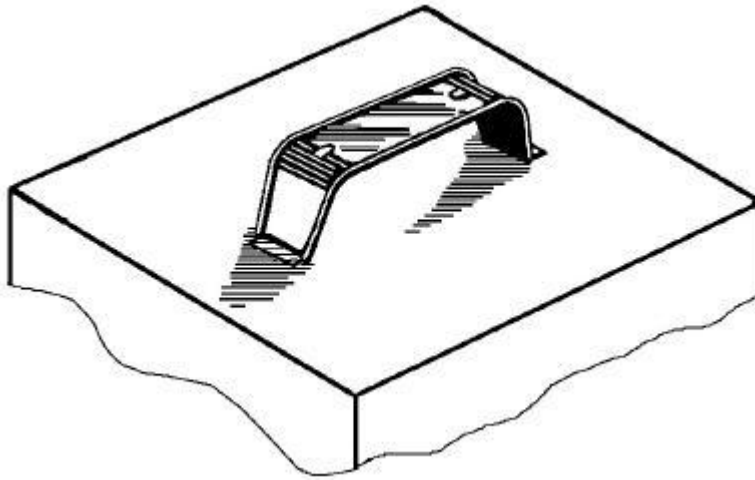

Special rules of classification

The use of available Indexing Codes is mandatory.

B65D 25/2829

{provided vertically and fixed to the upper and the lower rims or edges}

Definition statement

This place covers:

Illustrative example of subject matter classified in this group:

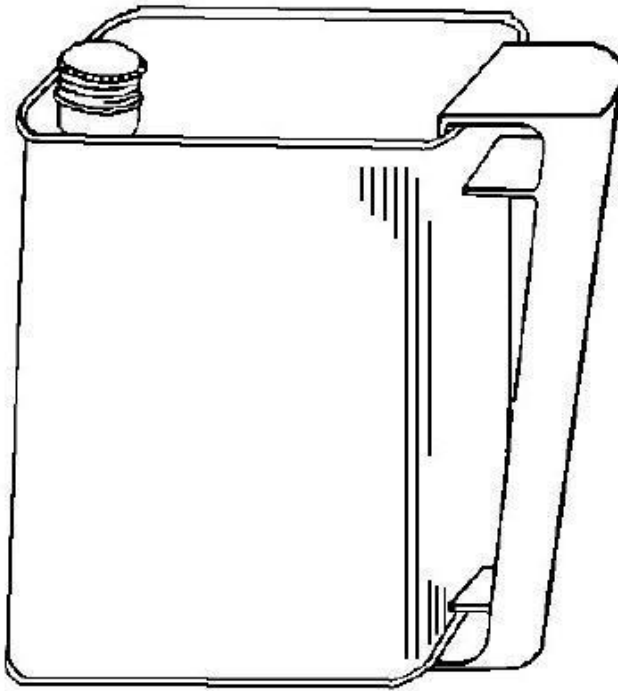

Special rules of classification

The use of available Indexing Codes is mandatory.

B65D 25/2832

{provided vertically and fixed to the upper or lower rim and to the side wall}

Definition statement

This place covers:

Illustrative example of subject matter classified in this group:

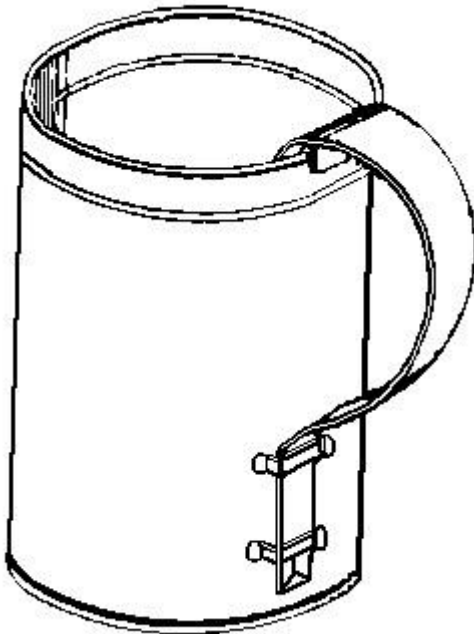
**Special rules of classification**

The use of available Indexing Codes is mandatory.

B65D 25/2835

{Swingable handles ([B65D 25/2867](#) and [B65D 25/2882](#) take precedence; bails [B65D 25/32](#))}

References**Limiting references**

This place does not cover:

With respective ends fixed to local areas of two opposite sides or wall-part	B65D 25/2867
Integral handles	B65D 25/2882

Special rules of classification

The use of available Indexing Codes is mandatory.

B65D 25/2838

{provided on a local area of the side wall(s)}

Special rules of classification

The use of available Indexing Codes is mandatory.

B65D 25/2841

{Horizontal, e.g. U-shaped}

Definition statement

This place covers:

Illustrative example of subject matter classified in this group:

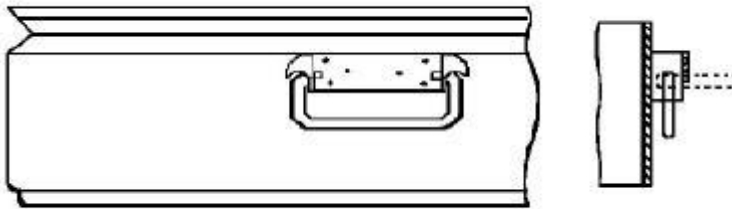

Special rules of classification

The use of available Indexing Codes is mandatory.

B65D 25/2844

{Vertical, e.g. U-shaped}

Definition statement

This place covers:

Illustrative example of subject matter classified in this group:

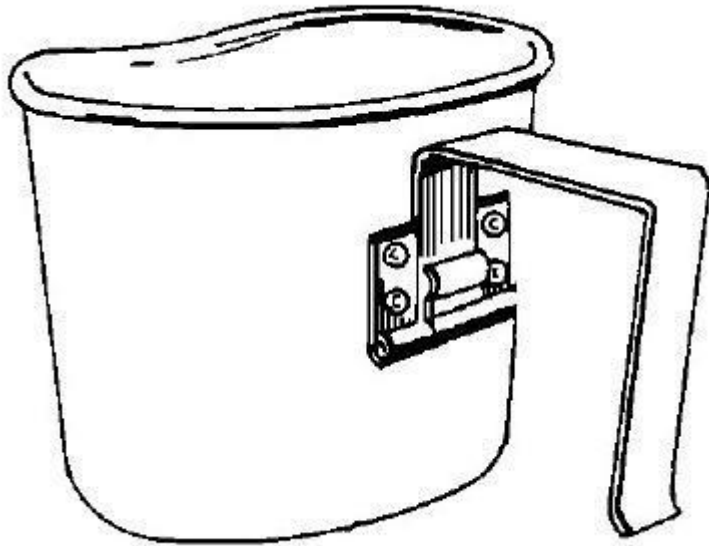

Special rules of classification

The use of available Indexing Codes is mandatory.

B65D 25/2847

{as a part or combined with a label or wrapping sheet or tube}

Definition statement

This place covers:

Illustrative example of subject matter classified in this group:

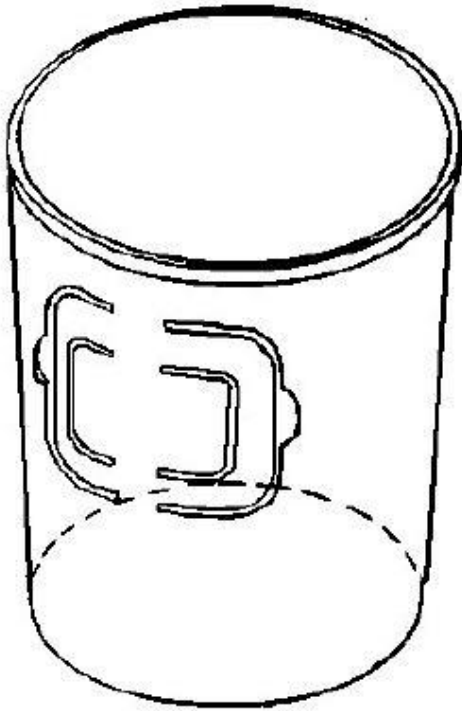

Special rules of classification

The use of available Indexing Codes is mandatory.

B65D 25/285

{fixed by means of one or more collars}

Definition statement

This place covers:

Illustrative example of subject matter classified in this group:

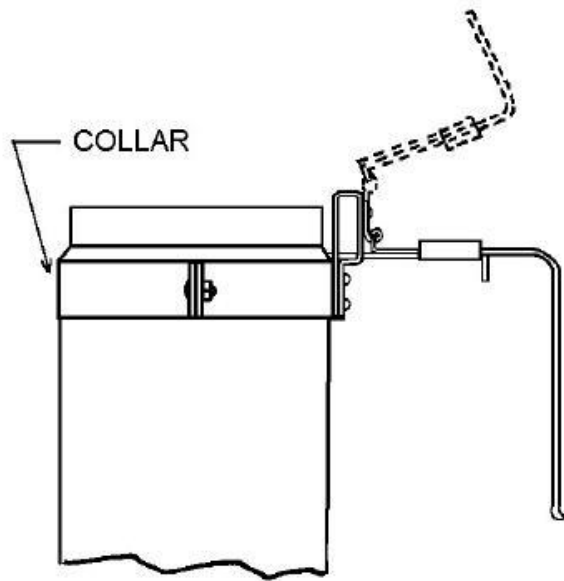

Special rules of classification

The use of available Indexing Codes is mandatory.

B65D 25/2852

{provided on a local area near to or at the upper edge or rim}

Definition statement

This place covers:

Illustrative example of subject matter classified in this group:

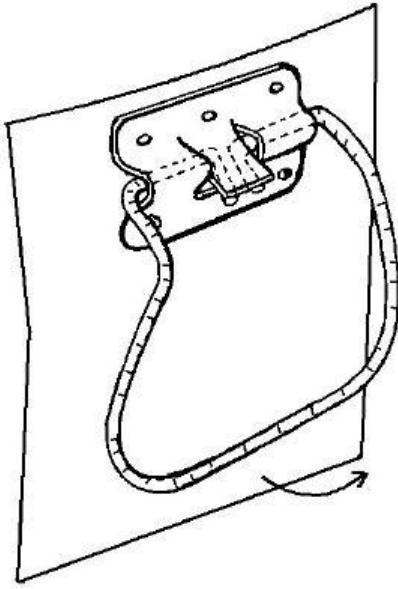

Special rules of classification

The use of available Indexing Codes is mandatory.

B65D 25/2855

{centrally located in open container}

Definition statement

This place covers:

Illustrative example of subject matter classified in this group:

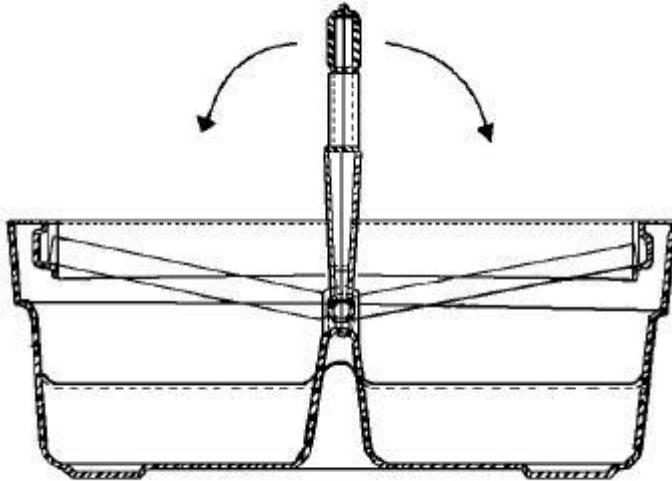

Special rules of classification

The use of available Indexing Codes is mandatory.

B65D 25/2858

{provided on a local area of the upper (top) wall, e.g. U-shaped}

Definition statement

This place covers:

Illustrative example of subject matter classified in this group:

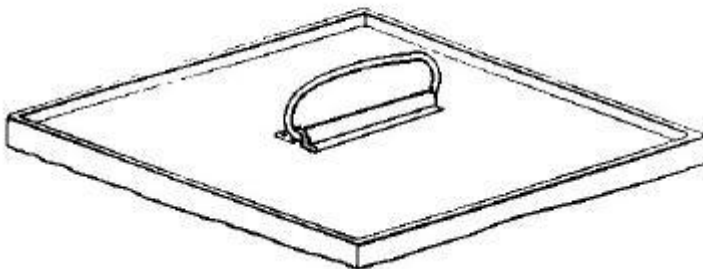

Special rules of classification

The use of available Indexing Codes is mandatory.

B65D 25/2861

{provided vertically and fixed to the upper and the lower rims or edges}

Definition statement

This place covers:

Illustrative example of subject matter classified in this group:

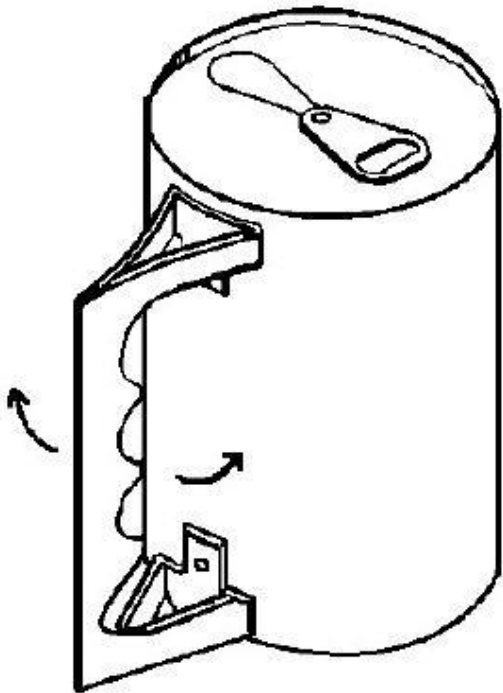
**Special rules of classification**

The use of available Indexing Codes is mandatory.

B65D 25/2864

{provided vertically and fixed to the upper or lower rim and to the side wall}

Special rules of classification

The use of available Indexing Codes is mandatory.

B65D 25/2867

{with respective ends fixed to local areas of two opposite sides or wall-part (bails [B65D 25/32](#))}

Special rules of classification

The use of available Indexing Codes is mandatory.

B65D 25/287

{Rope or string}

Definition statement

This place covers:

Illustrative example of subject matter classified in this group:

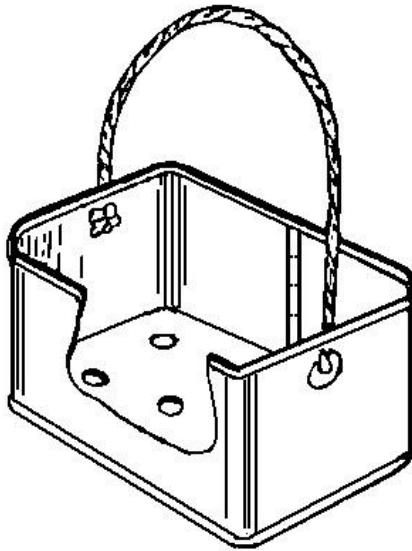

Special rules of classification

The use of available Indexing Codes is mandatory.

B65D 25/2873

{Straps or slings}

Definition statement

This place covers:

Illustrative example of subject matter classified in this group:

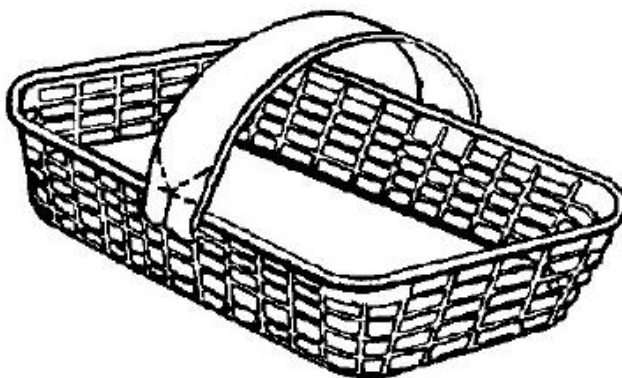

B65D 25/2876

{fixed by means of a collar}

Definition statement

This place covers:

Illustrative example of subject matter classified in this group:

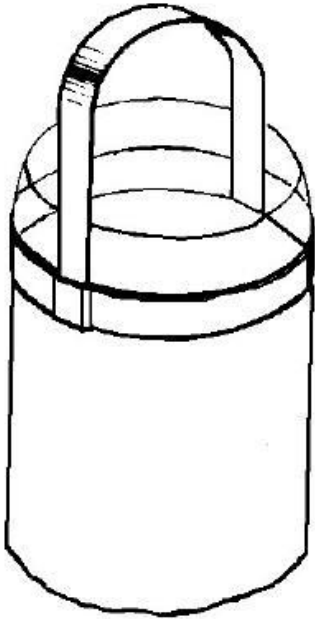

Special rules of classification

The use of available Indexing Codes is mandatory.

B65D 25/2879**{wire-like}****Definition statement***This place covers:*

Illustrative example of subject matter classified in this group:

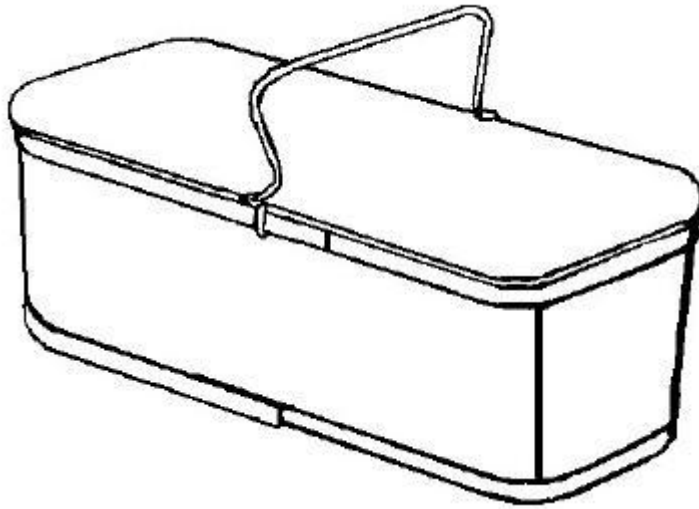
**Special rules of classification**

The use of available Indexing Codes is mandatory.

B65D 25/2882**{Integral handles ([B65D 25/2867](#) takes precedence)}****References****Limiting references***This place does not cover:*

With respective ends fixed to local areas of two opposite sides or wall-part	B65D 25/2867
--	------------------------------

Special rules of classification

The use of available Indexing Codes is mandatory.

B65D 25/2885

{provided on the side wall}

Definition statement

This place covers:

Illustrative example of subject matter classified in this group:

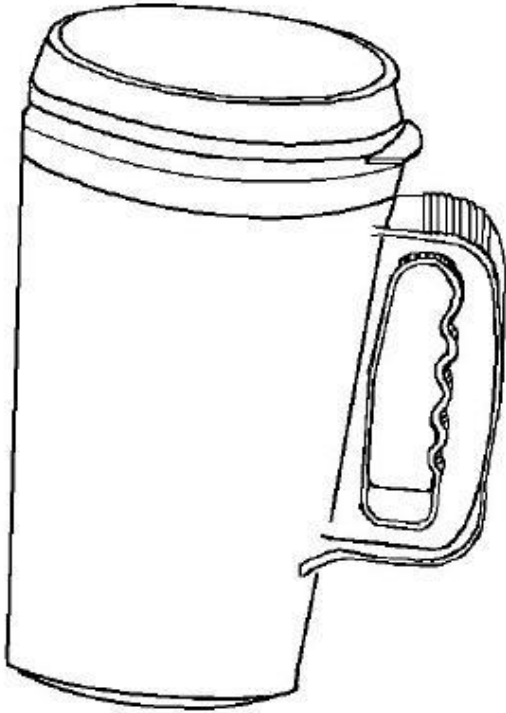

Special rules of classification

The use of available Indexing Codes is mandatory.

B65D 25/2888

{provided near to or at the upper edge or rim}

Definition statement

This place covers:

Illustrative example of subject matter classified in this group:

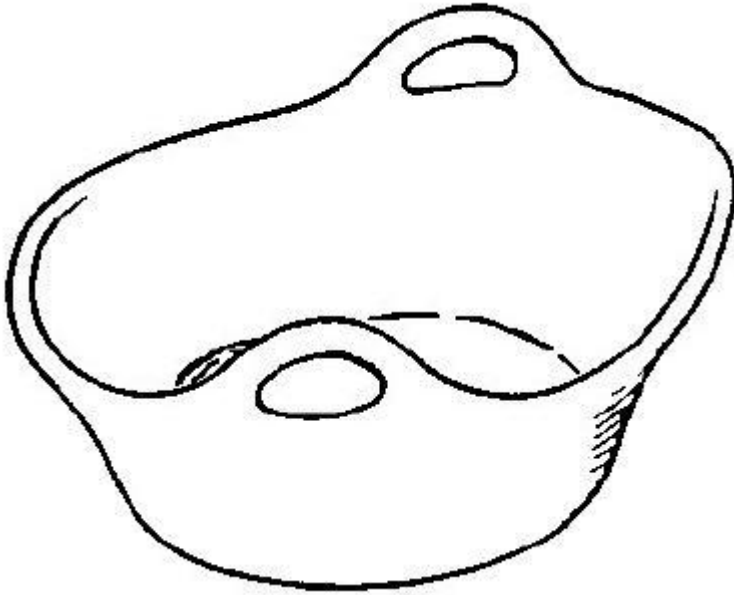

Special rules of classification

The use of available Indexing Codes is mandatory.

B65D 25/2891

{centrally located in open container}

Definition statement

This place covers:

Illustrative example of subject matter classified in this group:

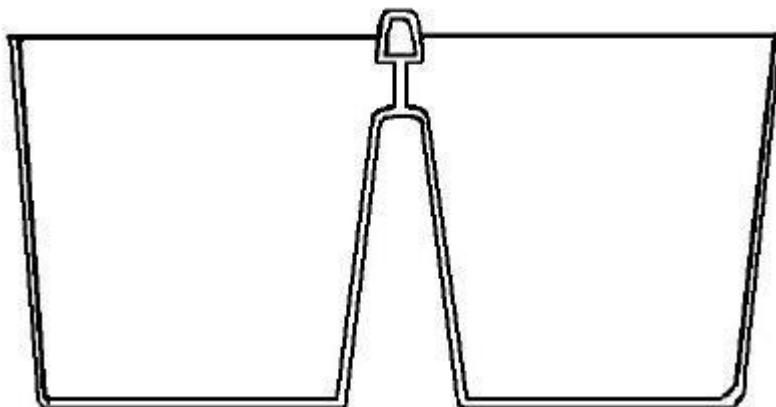

Special rules of classification

The use of available Indexing Codes is mandatory.

B65D 25/2894

{provided on the top or upper wall}

Definition statement

This place covers:

Illustrative example of subject matter classified in this group:

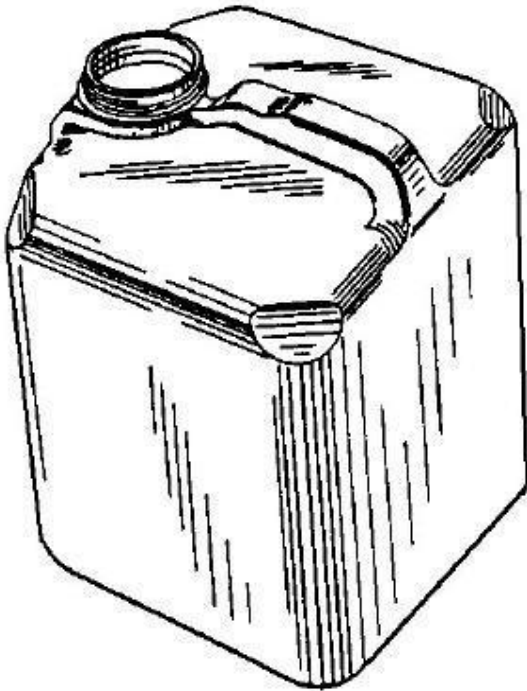

Special rules of classification

The use of available Indexing Codes is mandatory.

B65D 25/2897

{formed in the wall(s), e.g. roughenings, cavities or projections}

Definion statement

This place covers:

Illustrative example of subject matter classified in this group:

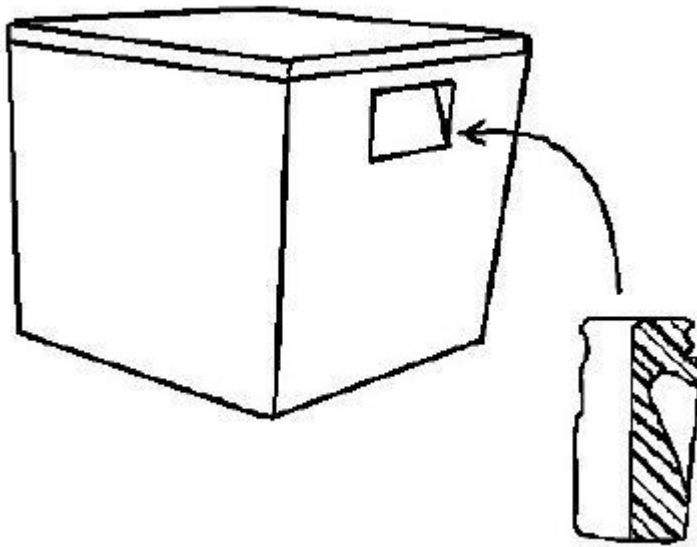

Special rules of classification

The use of available Indexing Codes is mandatory.

B65D 25/30

Hand holes

Definition statement

This place covers:

Illustrative example of subject matter classified in this group:

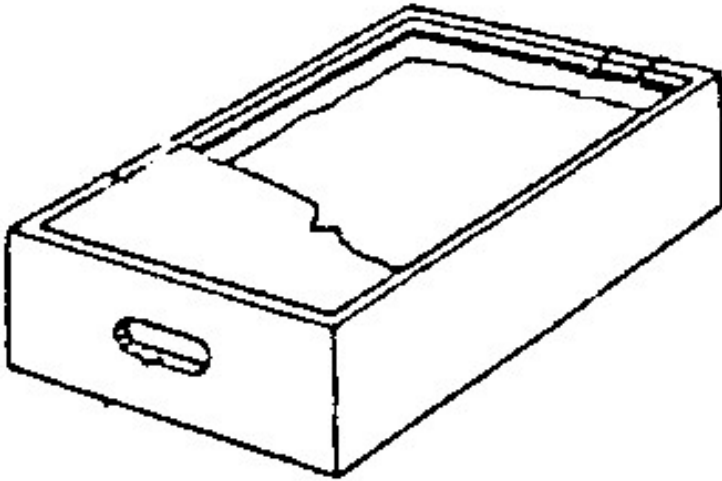

B65D 25/32

Bail handles, i.e. pivoted {rigid} handles of generally semi-circular shape {with pivot points on two opposed sides or wall parts of the container}

Definition statement

This place covers:

Illustrative example of subject matter classified in this group:

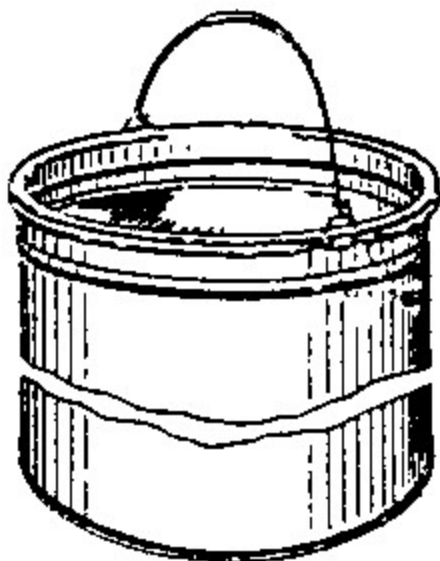

References

Informative references

Attention is drawn to the following places, which may be of interest for search:

Bail handles, i.e. pivoted handles of generally semi-circular or loop shape	B65D 23/108
Bails, e.g. for pails, for kettles	A47J 45/065
Pails for kitchen use	A47J 47/18

B65D 25/325

{integrally formed with the container}

Definition statement

This place covers:

Illustrative example of subject matter classified in this group:

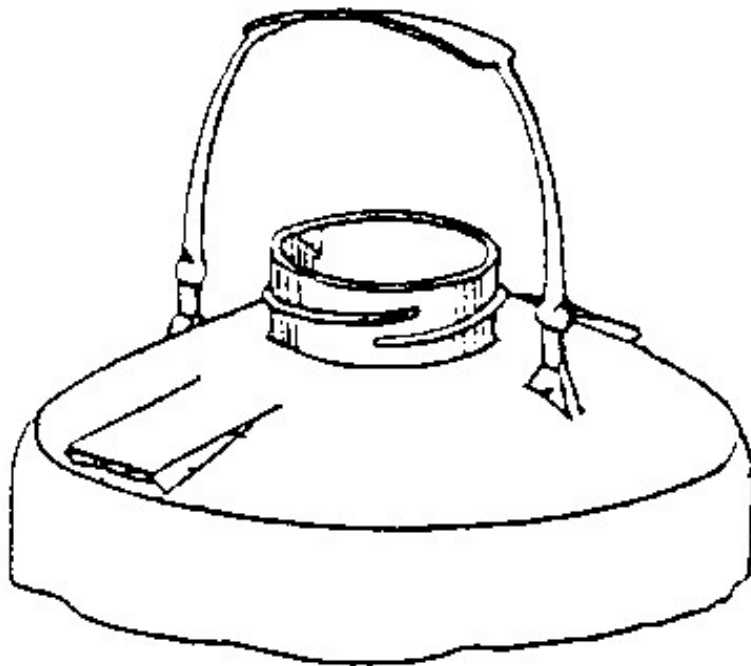

B65D 25/34

Coverings or external coatings (of containers made by folding or erecting blanks made of paper [B65D 5/62](#); for bottles or jars [B65D 23/08](#); wrappers [B65D 65/00](#))

Definition statement

This place covers:

Illustrative example of subject matter classified in this group:

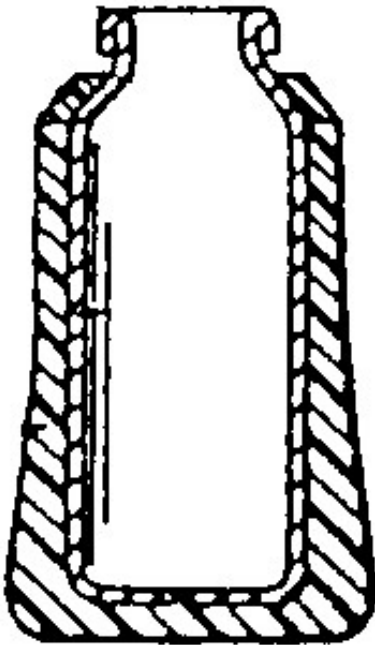

References

Informative references

Attention is drawn to the following places, which may be of interest for search:

External coverings or coatings	B65D 5/62
--------------------------------	---------------------------

B65D 25/36

formed by applying sheet material

Definition statement

This place covers:

Illustrative example of subject matter classified in this group:

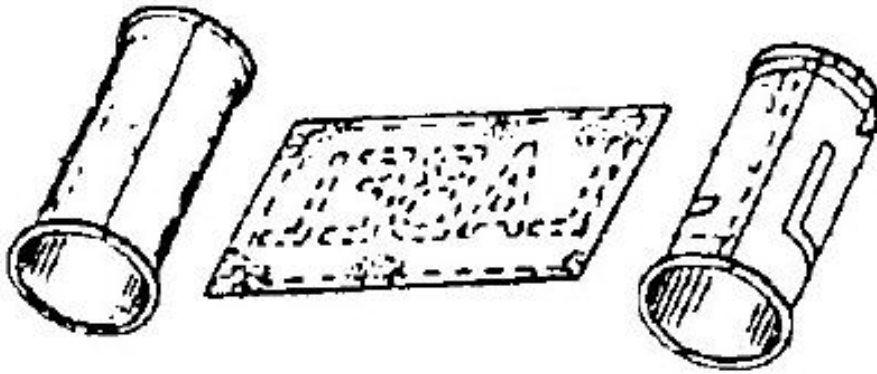
**References****Informative references**

Attention is drawn to the following places, which may be of interest for search:

External coverings or coatings	B65D 5/62
Articles enclosed in rigid or semi-rigid containers, the whole being wrapped	B65D 77/003

B65D 25/38

Devices for discharging contents (containers formed by folding or erecting paper blanks [B65D 5/72](#) ; incorporated in removable or non-permanently secured closure members [B65D 47/00](#); for discharging thin flat articles [B65D 83/08](#))

References**Limiting references**

This place does not cover:

Devices for releasing contents from the container, e.g. demoulding	B65D 85/72
--	----------------------------

Informative references

Attention is drawn to the following places, which may be of interest for search:

Pre-cut holes per weakened zones	B65D 2231/02
----------------------------------	------------------------------

B65D 25/385

{with means for preventing inflammation or explosion during discharging of inflammable or explosive substances from containers, e.g. from petroleum cans}

Definition statement

This place covers:

Illustrative example of subject matter classified in this group:

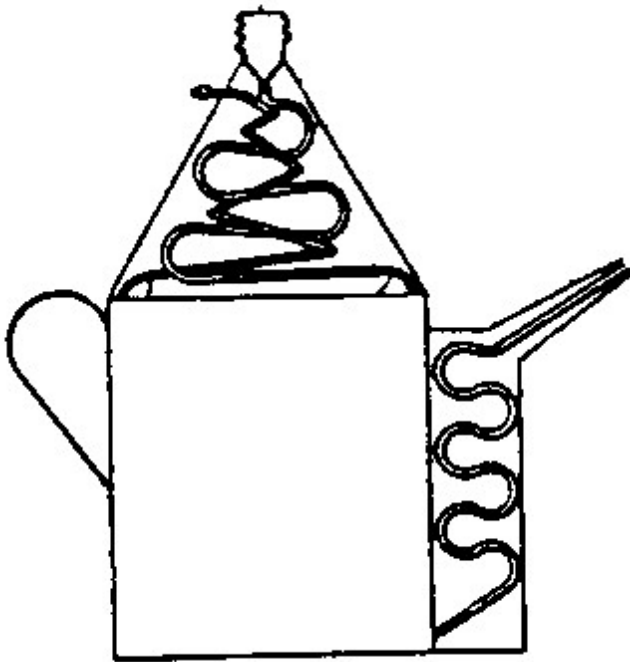
**B65D 25/40**

Nozzles or spouts (in general [B05B](#))

References**Limiting references**

This place does not cover:

Caulking nozzles	B05C 17/00503
------------------	-------------------------------

Informative references

Attention is drawn to the following places, which may be of interest for search:

Closures, with discharging devices other than pumps, with pouring spouts or tubes with discharge nozzles or passages	B65D 47/06
--	----------------------------

B65D 25/42**Integral or attached nozzles or spouts****Definition statement**

This place covers:

Illustrative example of subject matter classified in this group:

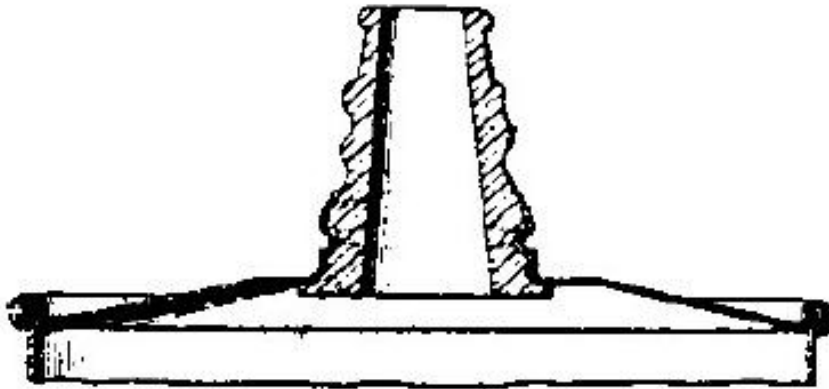
**References****Limiting references**

This place does not cover:

Caulking nozzles	B05C 17/005
------------------	-----------------------------

Informative references

Attention is drawn to the following places, which may be of interest for search:

Closures, with discharging devices other than pumps, with pouring spouts or tubes with discharge nozzles or passages	B65D 47/06
--	----------------------------

B65D 25/44**Telescopic or retractable nozzles or spouts****Definition statement**

This place covers:

Illustrative example of subject matter classified in this group:

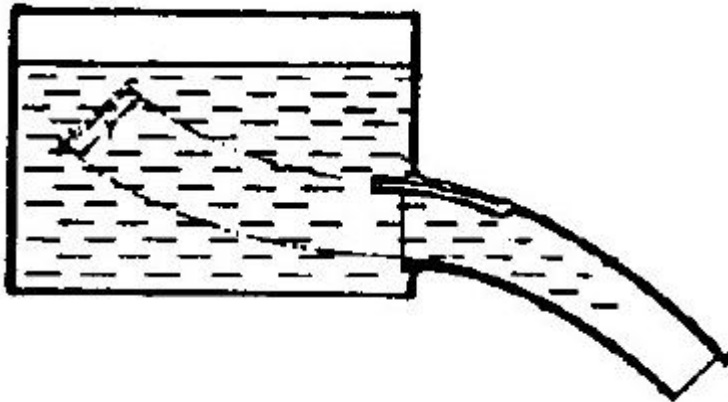
**References****Limiting references**

This place does not cover:

Caulking nozzles	B05C 17/00503
------------------	-------------------------------

Informative references

Attention is drawn to the following places, which may be of interest for search:

Closures, with discharging devices other than pumps, with flexible parts	B65D 47/061
--	-----------------------------

B65D 25/46**Hinged, {foldable} or pivoted nozzles or spouts****References****Limiting references**

This place does not cover:

Caulking nozzles	B05C 17/00503
------------------	-------------------------------

Informative references

Attention is drawn to the following places, which may be of interest for search:

Closures, with discharging devices other than pumps, with pouring spouts or tubes with discharge nozzles or passages	B65D 47/065
--	-----------------------------

B65D 25/465

{the spout being either flexible or having a flexible wall portion, whereby the spout is foldable between a dispensing and a non-dispensing position}

Definition statement

This place covers:

Illustrative example of subject matter classified in this group:

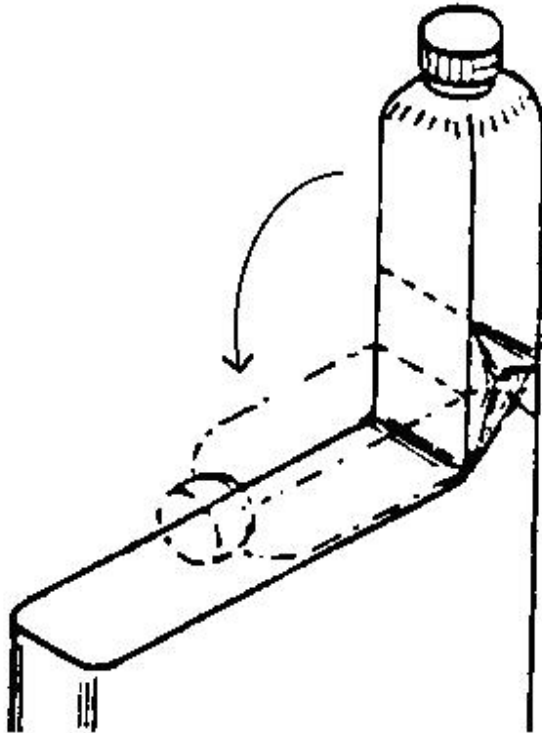
**References****Limiting references**

This place does not cover:

Bellows-like spouts	B65D 25/44
Caulking nozzles	B05C 17/00503

Informative references

Attention is drawn to the following places, which may be of interest for search:

The spout being either flexible or having a flexible wall portion, whereby the spout is foldable between a dispensing and a non-dispensing position	B65D 47/066
---	-----------------------------

B65D 25/48

Separable nozzles or spouts

Definition statement

This place covers:

Illustrative example of subject matter classified in this group:

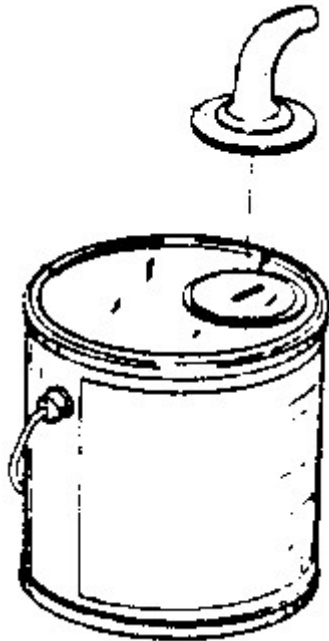

References

Limiting references

This place does not cover:

Caulking nozzles	B05C 17/00503
------------------	-------------------------------

Special rules of classification

The use of available Indexing Codes is mandatory.

B65D 25/50**arranged to be plugged in two alternate positions****Definition statement***This place covers:*

Illustrative example of subject matter classified in this group:

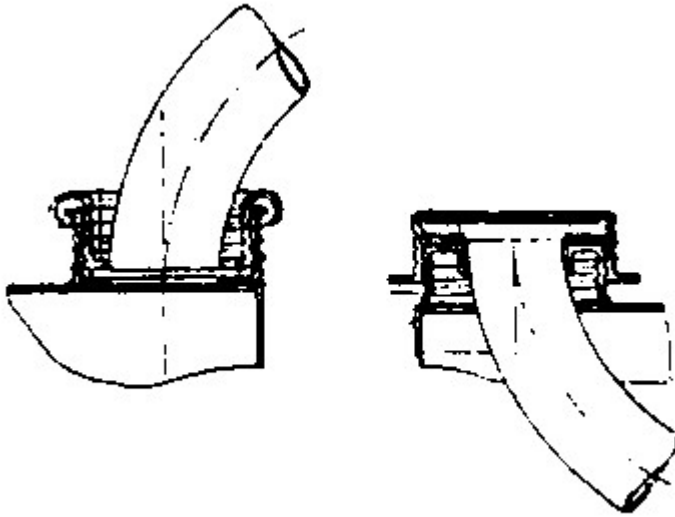
**References****Informative references***Attention is drawn to the following places, which may be of interest for search:*

With removable spouts which can be plugged in a discharging and in a position	B65D 47/068
---	-----------------------------

B65D 25/52**Devices for discharging successive articles or portions of contents****References****Informative references***Attention is drawn to the following places, which may be of interest for search:*

Contents-dispensing means for discharging metered quantities	B65D 5/76
--	---------------------------

B65D 25/525**{Swivelling devices, comprising a bottom wall and two side walls}****Definition statement***This place covers:*

Illustrative example of subject matter classified in this group:

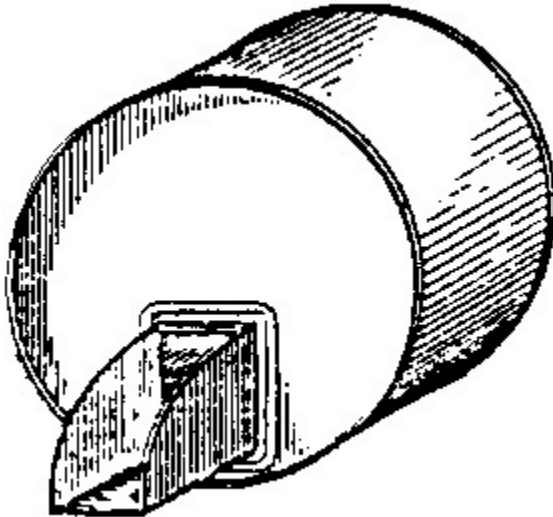
**References*****Informative references****Attention is drawn to the following places, which may be of interest for search:*

Closures with swivelling dispensing devices(containers with swivelling devices comprising a bottom wall and two side walls	B65D 47/046
--	-----------------------------

B65D 25/54**Inspection openings or windows****Definition statement**

This place covers:

Illustrative example of subject matter classified in this group:

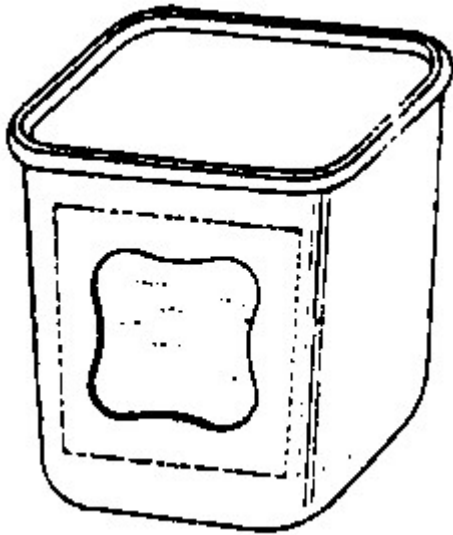
**References****Limiting references**

This place does not cover:

Side walls formed with an aperture or a movable portion arranged to allow removal or insertion of contents	B65D 25/005
--	-----------------------------

B65D 25/56

with means for indicating level of contents

Definition statement

This place covers:

Illustrative example of subject matter classified in this group:

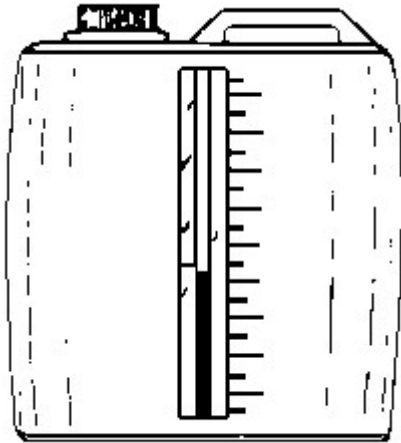
**References****Limiting references**

This place does not cover:

Measuring cups	G01F 19/00
----------------	----------------------------

B65D 27/00

Envelopes or like essentially-rectangular containers for postal or other purposes having no structural provision for thickness of contents (with shock-absorbing properties [B65D 81/03](#); letter-cards [B42D 15/00](#))

References**Limiting references**

This place does not cover:

Envelopes having string handles or a string hook	B65D 33/12
For records	B65D 85/544
Making mailing envelopes	B31B 70/00 , B31B 2150/00 , B31B 2160/10
Carbon paper transfer	B41L 11/00

Special rules of classification

The use of available Indexing Codes is mandatory.

B65D 27/005

{Linings}

Definition statement

This place covers:

Illustrative example of subject matter classified in this group:

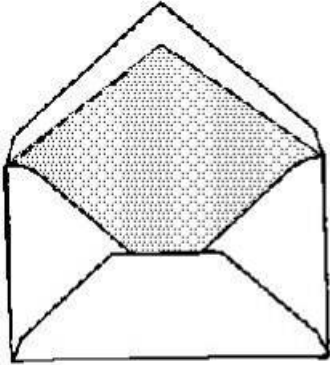

B65D 27/02

with stiffening inserts

Definition statement

This place covers:

Illustrative example of subject matter classified in this group:

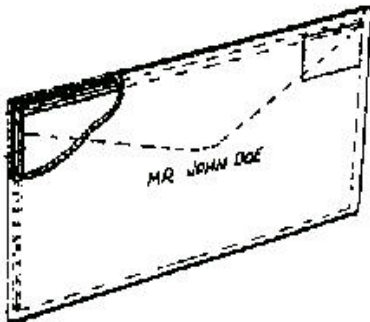

B65D 27/04

with apertures or windows for viewing contents

Definition statement

This place covers:

Illustrative example of subject matter classified in this group:

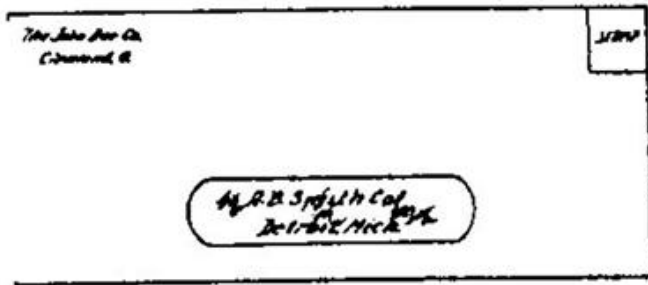

B65D 27/06

with provisions for repeated re-use

Definition statement

This place covers:

Illustrative example of subject matter classified in this group:

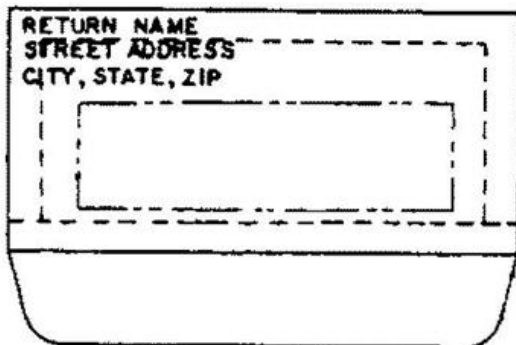

B65D 27/08

with two or more compartments

Definition statement

This place covers:

Illustrative example of subject matter classified in this group:

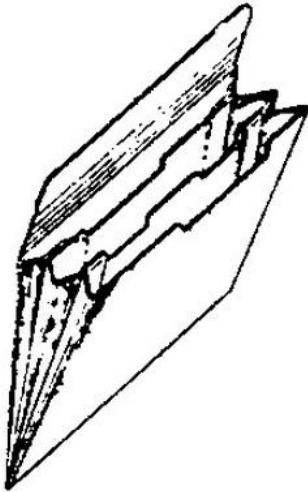

B65D 27/10

Chains of interconnected envelopes

Definition statement

This place covers:

Illustrative example of subject matter classified in this group:

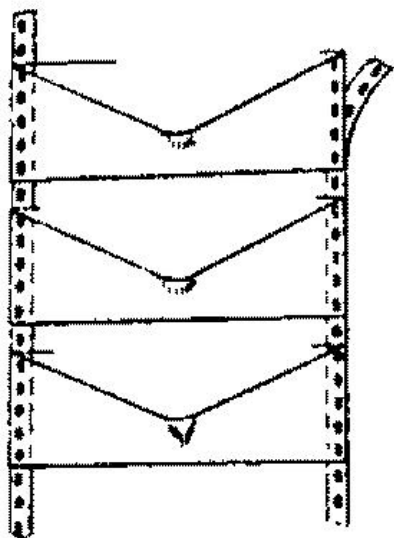

References**Limiting references**

This place does not cover:

Mailers and other chain forms	B42D
-------------------------------	----------------------

B65D 27/14

using adhesive applied to integral parts, e.g. flaps

Definition statement

This place covers:

Illustrative example of subject matter classified in this group:

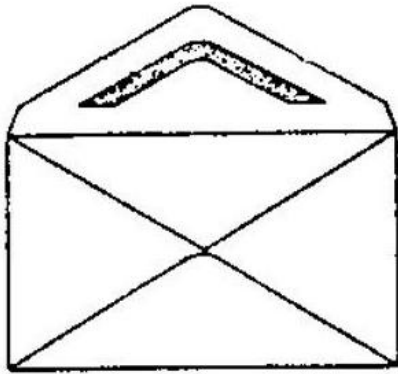
**B65D 27/16**

using pressure-sensitive adhesive

Definition statement

This place covers:

Illustrative example of subject matter classified in this group:

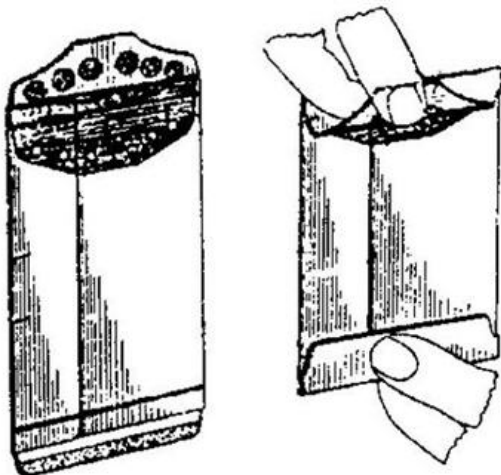

B65D 27/22

Tongue-and-slot or like closures; Tuck-in flaps

Definition statement

This place covers:

Illustrative example of subject matter classified in this group:

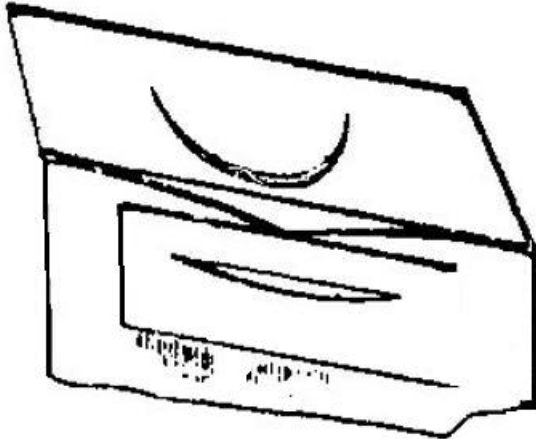

B65D 27/24

String closures

Definition statement

This place covers:

Illustrative example of subject matter classified in this group:

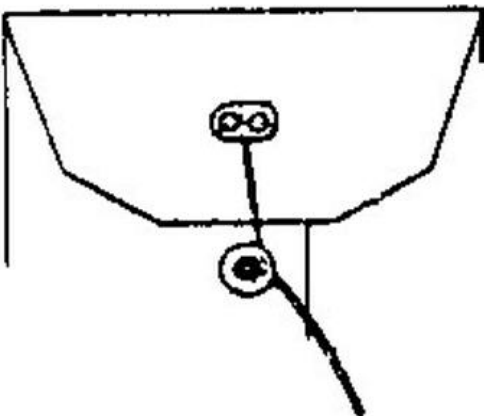

B65D 27/26

Deformable metallic elements

Definition statement

This place covers:

Illustrative example of subject matter classified in this group.

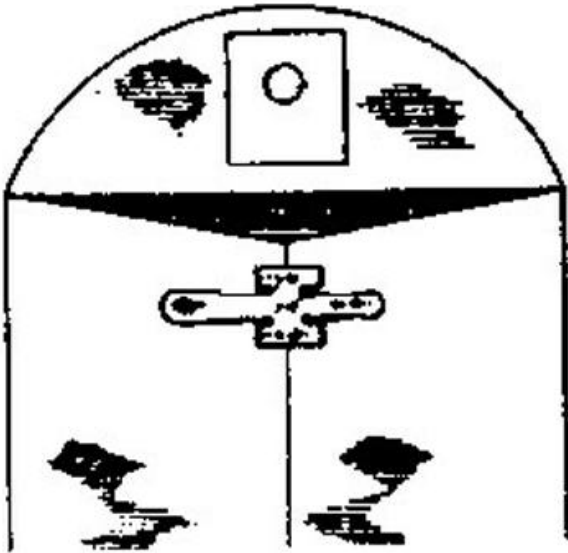

B65D 27/28

Applications of separate closing elements

Definition statement

This place covers:

Illustrative example of subject matter classified in this group:

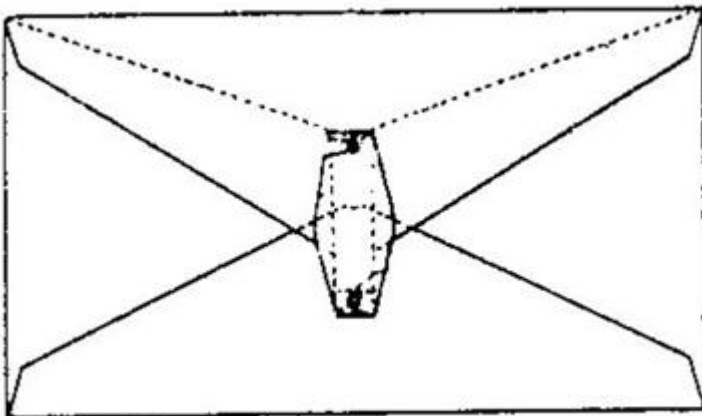

B65D 27/30**with special means for indicating unauthorised opening****Definition statement***This place covers:*

Illustrative example of subject matter classified in this group:

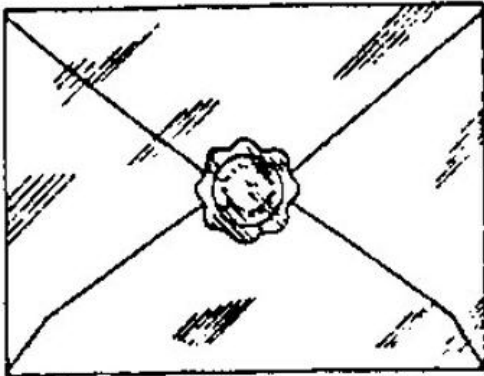
**References****Informative references***Attention is drawn to the following places, which may be of interest for search:*

Details of, or accessories for, sacks or bags with special means for indicating unauthorised opening	B65D 33/34
--	----------------------------

B65D 27/34**Lines of weakness****Definition statement***This place covers:*

Illustrative example of subject matter classified in this group:

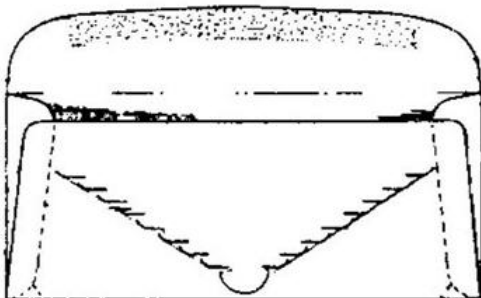

B65D 27/36**Finger openings, slots, or gripping tabs****Definition statement**

This place covers:

Illustrative example of subject matter classified in this group:

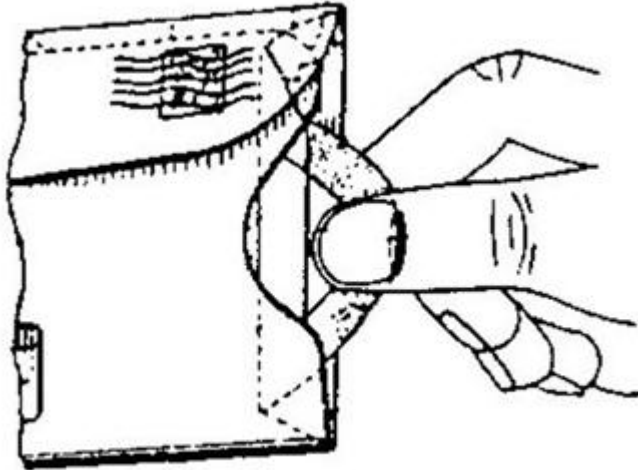
**B65D 27/38****Tearing-strings or -strips****Definition statement**

This place covers:

Illustrative example of subject matter classified in this group:

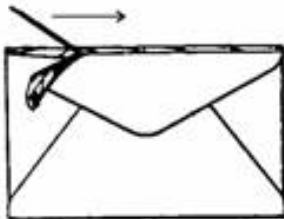
**References****Informative references**

Attention is drawn to the following places, which may be of interest for search:

Inserted or applied tearing-strings or like flexible elements	B65D 75/66
Tearing-strings or like flexible elements	B65D 77/32

B65D 29/00

{Sacks or like containers made of fabrics; Flexible containers of open-work, e.g. net-like construction}

Definition statement

This place covers:

Illustrative example of subject matter classified in this group:

**References****Limiting references**

This place does not cover:

Postal bags with safety closure	B65D 77/185
Shopping nets	A45C 3/04

B65D 29/02

{Sacks with laminated or multiple walls}

Definition statement

This place covers:

Illustrative example of subject matter classified in this group:

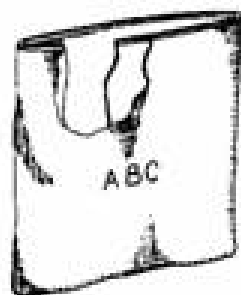

B65D 29/04**{Net-like containers made of plastics material}****Definition statement***This place covers:*

Illustrative example of subject matter classified in this group:

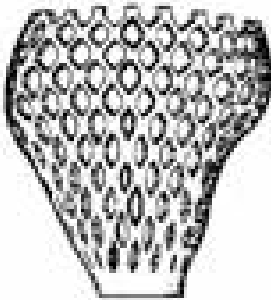
**References****Limiting references***This place does not cover:*

Net-like covers for bottles	B65D 23/0892
-----------------------------	------------------------------

Informative references*Attention is drawn to the following places, which may be of interest for search:*

Baskets or like containers of skeleton or apertured construction	B65D 1/38
Containers of skeleton or apertured construction, e.g. baskets or carriers made up of interconnected spaced bands, rods, or strings	B65D 11/14

B65D 31/00**{Bags or like containers made of paper and having structural provision for thickness of contents (with shock-absorbing properties [B65D 81/03](#))}****References****Limiting references***This place does not cover:*

Standing pouches	B65D 75/008
Flexible large bags	B65D 88/16
Tobacco pouches	A24F 23/02
Travelling bags	A45C
Manufacture of bags	B31B
Laundry bags	D06F 95/002
Bags for picking up excrement from public places	E01H 1/1206

B65D 31/005

{by folding a single blank to U-shape to form the base of the bag and opposite sides of the body-portion, the remaining sides being formed by extensions of one or more of these opposite sides (cartons [B65D 5/18](#))}

Definition statement

This place covers:

Illustrative example of subject matter classified in this group:

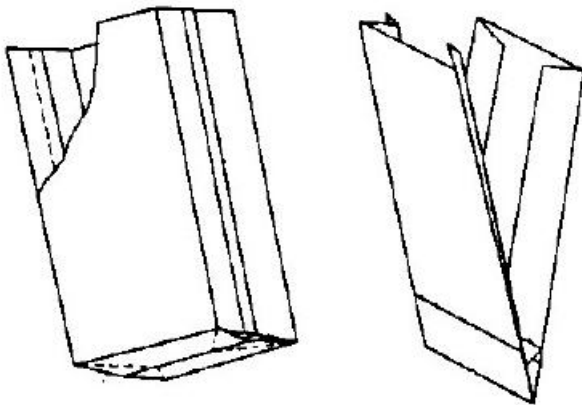

B65D 31/02

{with laminated walls}

Definition statement

This place covers:

Illustrative example of subject matter classified in this group:

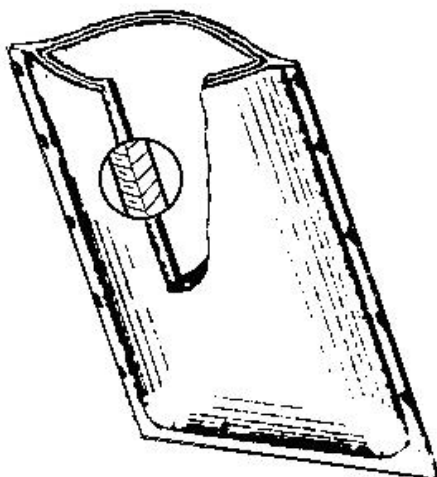

B65D 31/04

{with multiple walls ([B65D 81/3881](#) takes precedence; for shock absorbing purposes [B65D 81/03](#))}

Definition statement

This place covers:

Illustrative example of subject matter classified in this group:

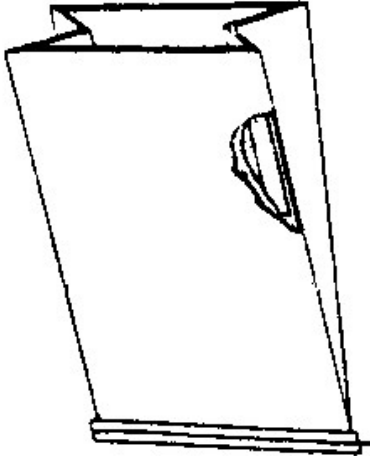
**References****Limiting references**

This place does not cover:

Containers, packaging elements, or packages with thermal insulation formed with double walls	B65D 81/3881
--	------------------------------

Informative references

Attention is drawn to the following places, which may be of interest for search:

Bags or like containers made of paper with laminated walls	B65D 31/02
--	----------------------------

B65D 31/06**{with rigid end walls}****Definition statement***This place covers:*

Illustrative example of subject matter classified in this group:

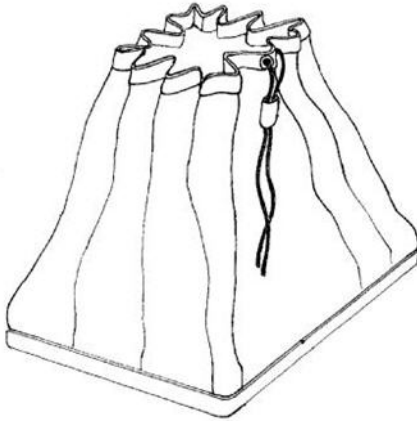
**References****Limiting references***This place does not cover:*

Rigid end bases for standing pouches	B65D 75/008
--------------------------------------	-----------------------------

Informative references*Attention is drawn to the following places, which may be of interest for search:*

Local reinforcements or stiffening inserts, e.g. wires, strings, strips, frames	B65D 33/02
---	----------------------------

B65D 31/08

{with block bottoms}

Definition statement

This place covers:

Illustrative example of subject matter classified in this group:

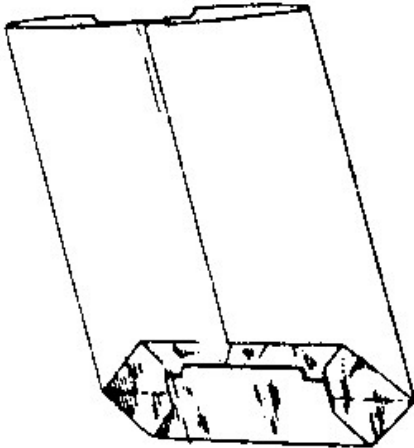

B65D 31/10

{with gusseted sides}

Definition statement

This place covers:

Illustrative example of subject matter classified in this group:

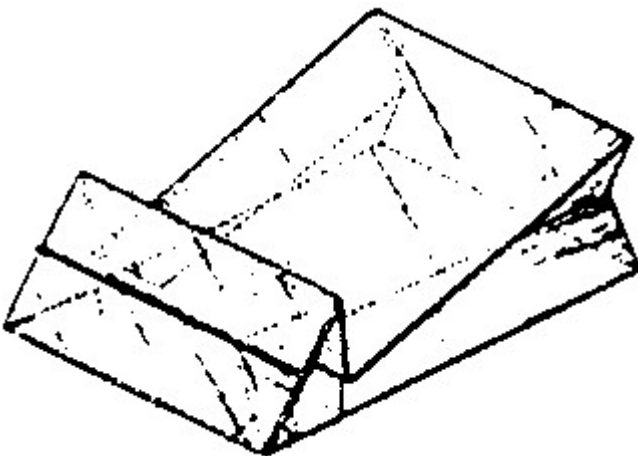

B65D 31/12**{with two or more compartments}****Definition statement***This place covers:*

Illustrative example of subject matter classified in this group:

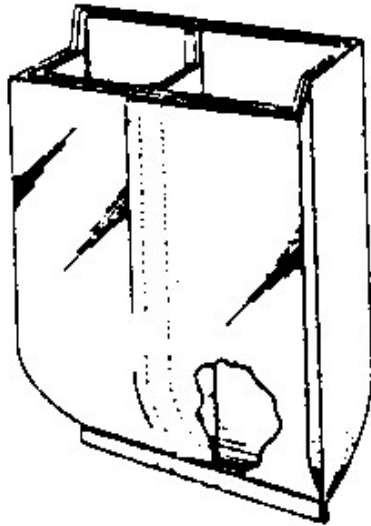
**References****Informative references***Attention is drawn to the following places, which may be of interest for search:*

Materials, e.g. different materials, enclosed in separate compartments formed during filling of a single container	B65D 77/08
--	----------------------------

B65D 31/14**{Valve bags, i.e. with valves for filling}****References****Limiting references***This place does not cover:*

Flexible pressure relief valves	B65D 77/225
Venting means	B65D 2205/00

B65D 31/142

{the filling port being formed by folding a flap connected to a side, e.g. block bottoms}

Definition statement

This place covers:

Illustrative example of subject matter classified in this group:

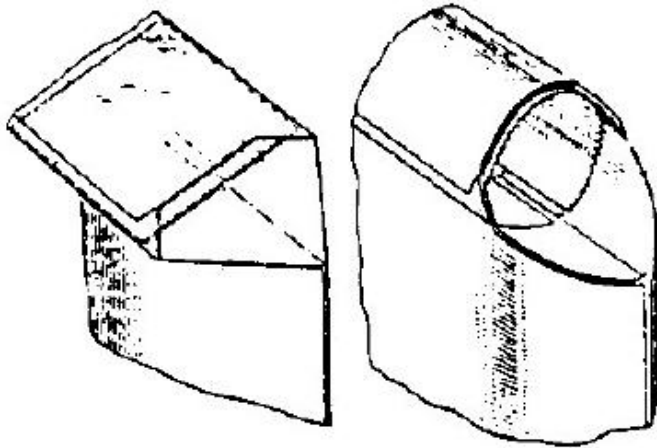

References

Limiting references

This place does not cover:

Flexible pressure relief valves	B65D 77/225
Venting means	B65D 2205/00

B65D 31/145

{the filling port being provided in a flat upper sealing-edge}

Definition statement

This place covers:

Illustrative example of subject matter classified in this group:

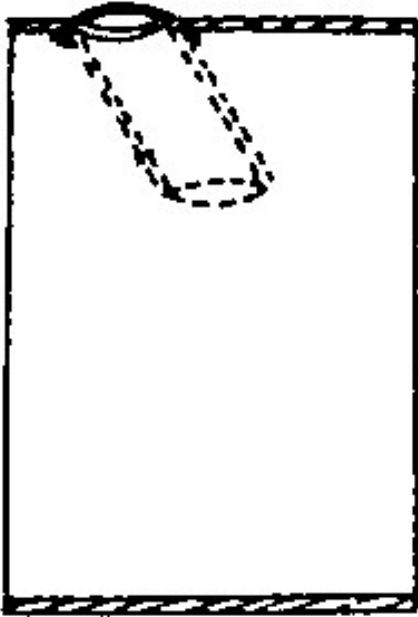
**References****Limiting references**

This place does not cover:

Flexible pressure relief valves	B65D 77/225
Venting means	B65D 2205/00

B65D 31/147

{the filling port being provided in a side wall}

Definition statement

This place covers:

Illustrative example of subject matter classified in this group:

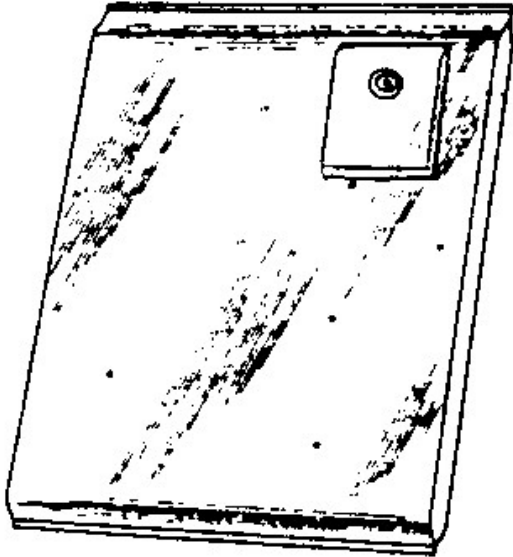
**References****Limiting references**

This place does not cover:

Flexible pressure relief valves	B65D 77/225
Venting means	B65D 2205/00

B65D 31/16

{of special shape}

Definition statement

This place covers:

Illustrative example of subject matter classified in this group:

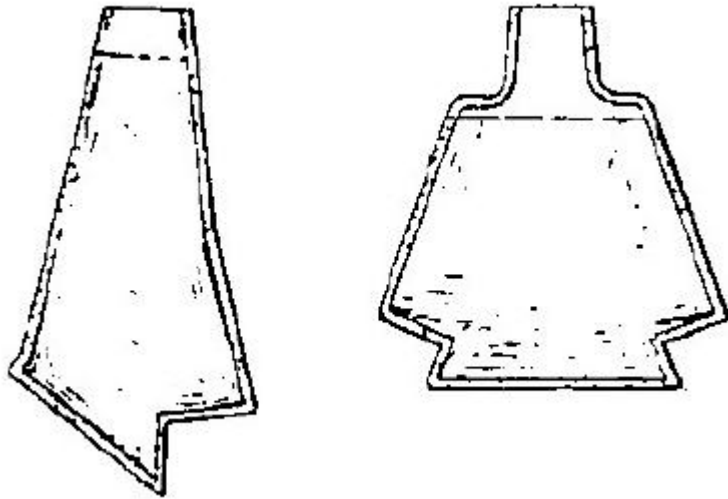

B65D 31/18

{Triangular or conical bags}

Definition statement

This place covers:

Illustrative example of subject matter classified in this group:

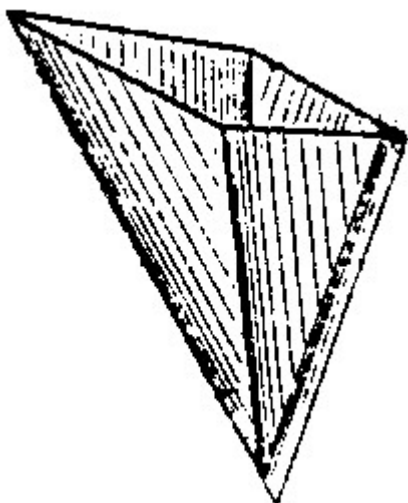

B65D 33/00**Details of, or accessories for, sacks or bags****References****Limiting references***This place does not cover:*

Pressure relief valves	B65D 77/225 , B65D 81/2038
Bags for the cultivation of mushrooms	A01G 18/64
Bags specially adapted for shopping trolleys	B62B 3/1464
Bags for microbiological cultures	C12M 1/16

Informative references*Attention is drawn to the following places, which may be of interest for search:*

Containers, packaging elements, or packages adapted to be used for non-packaging purposes after removal of contents	B65D 81/36
---	----------------------------

B65D 33/001**{Blocks, stacks or like assemblies of bags}****Definition statement***This place covers:*

Illustrative example of subject matter classified in this group:

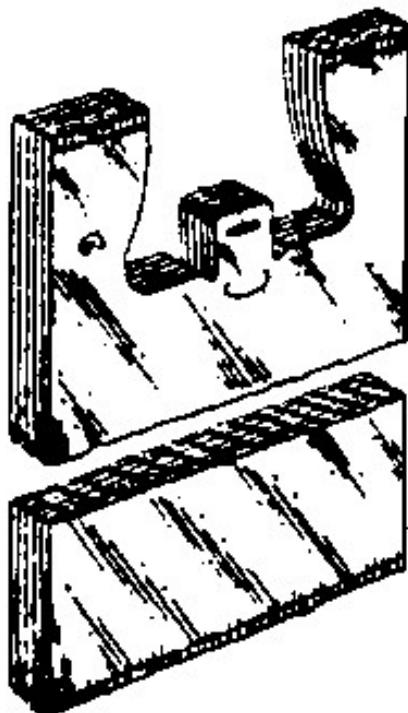

References

Limiting references

This place does not cover:

Shopping bags or carton-dispensing systems	A47F 9/042
Shopping bag holders	A47F 13/085
Feeding individual bags from piles or magazines	B65B 43/14

Informative references

Attention is drawn to the following places, which may be of interest for search:

Containers or packages with special means for dispensing thin flat articles in succession	B65D 83/08
---	----------------------------

B65D 33/002

{Rolls, strips or like assemblies of bags}

Definition statement

This place covers:

Illustrative example of subject matter classified in this group:

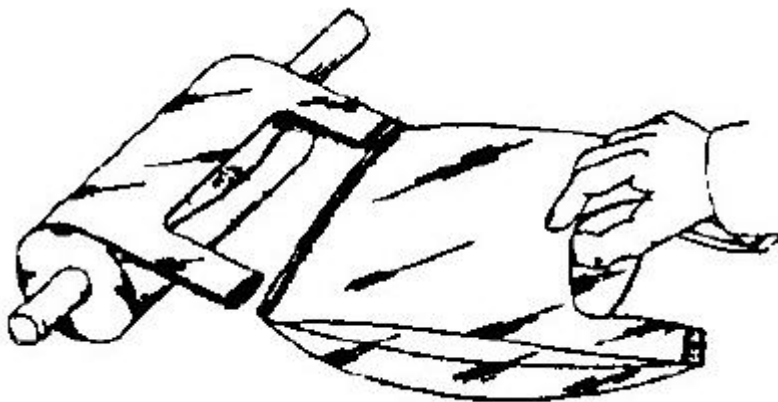

References

Informative references

Attention is drawn to the following places, which may be of interest for search:

Containers or packages with special means for dispensing thin flat articles in succession	B65D 83/08
---	----------------------------

B65D 33/004

{Information or decoration elements, e.g. level indicators, detachable tabs or coupons}

Definition statement

This place covers:

Illustrative example of subject matter classified in this group:

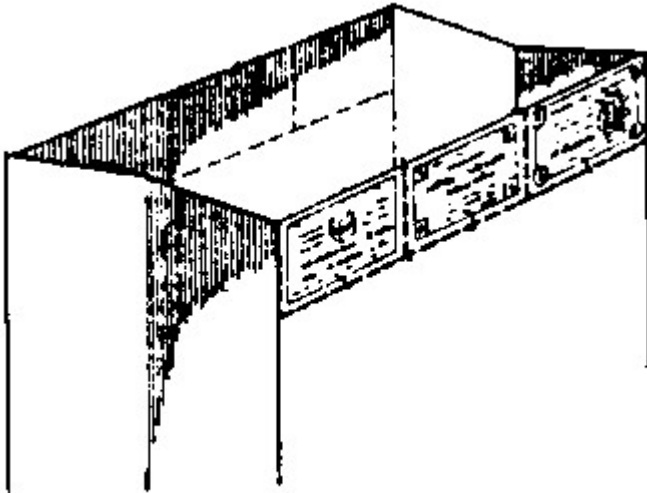
**References****Limiting references**

This place does not cover:

Decorative ribbons or rosettes	B65D 67/00
--------------------------------	----------------------------

Informative references

Attention is drawn to the following places, which may be of interest for search:

Information or decoration elements, e.g. content indicators, or for mailing	B65D 5/4212
Means for the attachments of tags	B65D 23/14
Means for the attachment of labels, cards, coupons or the like	B65D 25/205
The inserts being located with a pouch or envelope attached to the exterior of the packages	B65D 75/545

B65D 33/005

{Anti-slip or anti-skid bags, e.g. bags provided with anti-slip coating, ribs, strips}

Definition statement

This place covers:

Illustrative example of subject matter classified in this group:

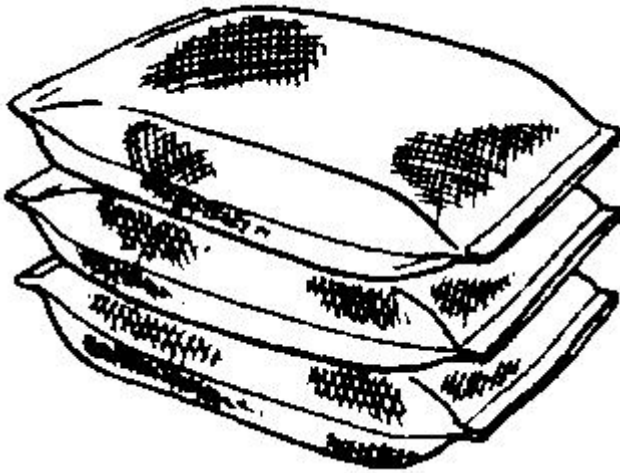

References

Limiting references

This place does not cover:

Anti-slip separators for articles packaged in stacks or groups	B65D 57/00
--	----------------------------

B65D 33/007

{for facilitating the separation of the two walls, e.g. walls of unequal height, tabs; for maintaining the mouth of the sack or bag open}

Definition statement

This place covers:

Illustrative example of subject matter classified in this group:

**References****Limiting references**

This place does not cover:

Two resilient self-closing bands	B65D 33/30
----------------------------------	----------------------------

B65D 33/008

{Individual filled bags or pouches connected together ([B65D 33/001](#), [B65D 33/002](#) take precedence)}

Definition statement

This place covers:

Illustrative example of subject matter classified in this group:

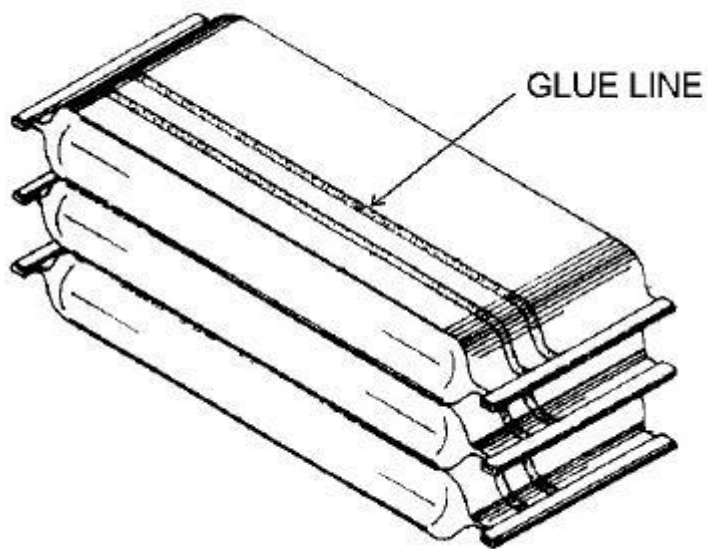
**References****Limiting references**

This place does not cover:

Blocks, stacks or like assemblies of bags	B65D 33/001
Rolls, strips or like assemblies of bags	B65D 33/002

Informative references

Attention is drawn to the following places, which may be of interest for search:

Flexible containers having several compartments	B65D 81/3261
---	------------------------------

B65D 33/01

Ventilation or drainage of bags

Definition statement

This place covers:

Illustrative example of subject matter classified in this group:

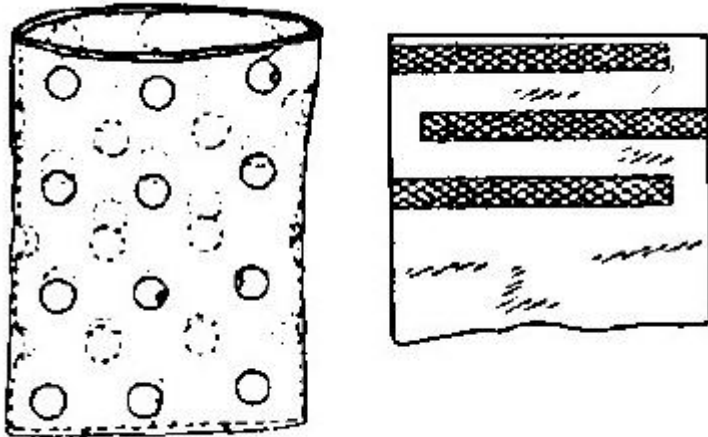

References

Informative references

Attention is drawn to the following places, which may be of interest for search:

Venting means	B65D 2205/00
---------------	------------------------------

B65D 33/02

Local reinforcements or stiffening inserts, e.g. wires, strings, strips or frames
 {([B65D 33/007](#) takes precedence)}

Definition statement

This place covers:

Illustrative example of subject matter classified in this group:

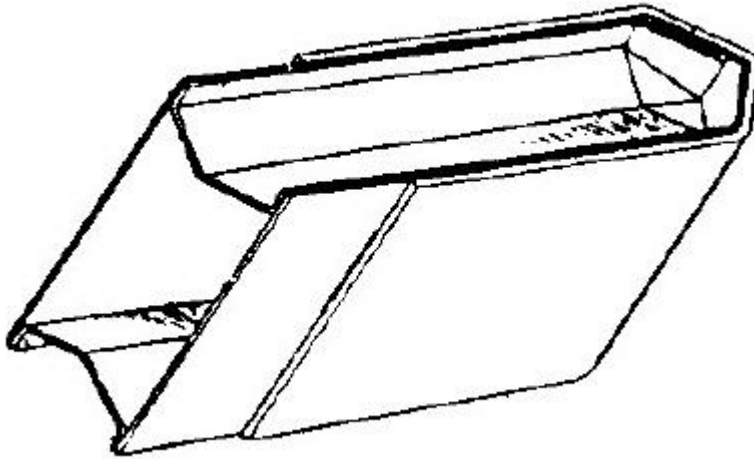
**References****Limiting references**

This place does not cover:

For maintaining the mouth of the bag open	B65D 33/007
Around a hand hole	B65D 33/08
Internal frames	B65D 57/00
External frames	B65D 61/00

B65D 33/04

Windows or other apertures, e.g. for viewing contents {(ventilation apertures [B65D 33/01](#); windows for level indication [B65D 33/004](#))}

Definition statement

This place covers:

Illustrative example of subject matter classified in this group:

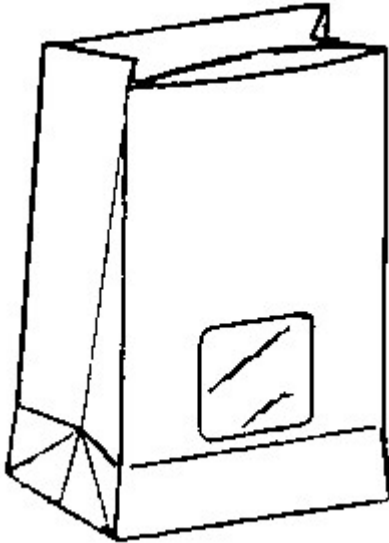

References

Informative references

Attention is drawn to the following places, which may be of interest for search:

Wrappers or flexible covers with some areas transparent and others opaque	B65D 65/18
Inspection openings or windows	B65D 75/522
Means or constructions for testing or controlling the contents	B65D 2201/00

B65D 33/06**Handles {(forming part of the closing arrangement [B65D 33/16](#))}****Definition statement***This place covers:*

Illustrative example of subject matter classified in this group:

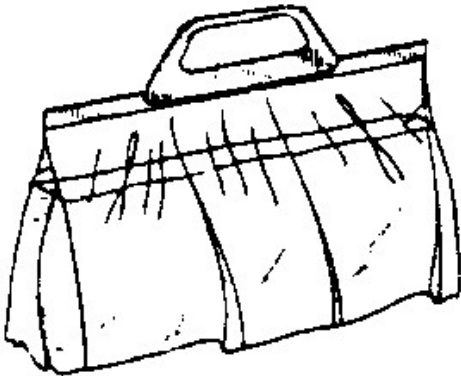
**References****Limiting references***This place does not cover:*

Loose handles for carrying purposes	A45F 5/10
-------------------------------------	---------------------------

B65D 33/065**{Integral handles ([B65D 33/08](#) takes precedence)}****Definition statement***This place covers:*

Illustrative example of subject matter classified in this group:

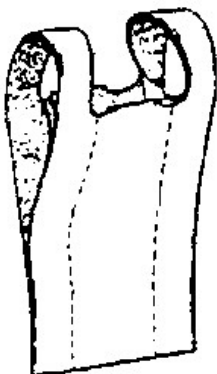

References

Limiting references

This place does not cover:

Hand holes	B65D 33/08
------------	----------------------------

B65D 33/08

Hand holes

Definition statement

This place covers:

Illustrative example of subject matter classified in this group:

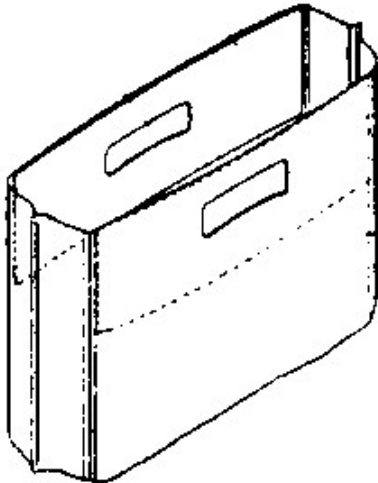

B65D 33/10

formed of similar material to that used for the bag

Definition statement

This place covers:

Illustrative example of subject matter classified in this group:

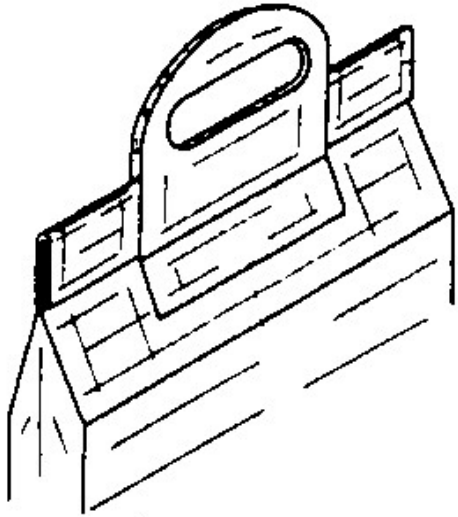

References

Limiting references

This place does not cover:

For packages in wrappers	B65D 75/56
--------------------------	----------------------------

B65D 33/105

{U-shaped}

Definition statement

This place covers:

Illustrative example of subject matter classified in this group:

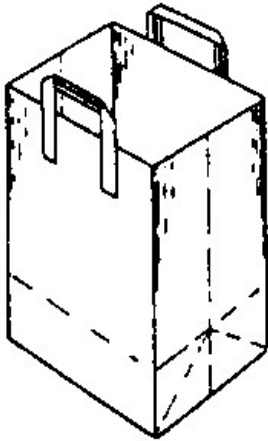

B65D 33/12

String handles

Definition statement

This place covers:

Illustrative example of subject matter classified in this group:

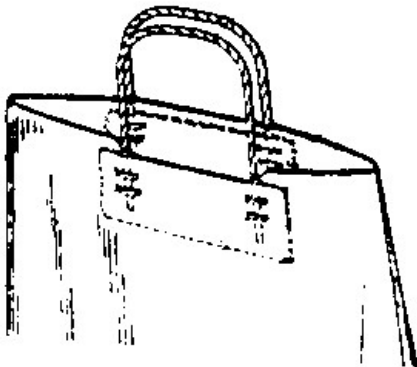

B65D 33/14**Suspension means (handles [B65D 33/06](#))****Definition statement***This place covers:*

Illustrative example of subject matter classified in this group:

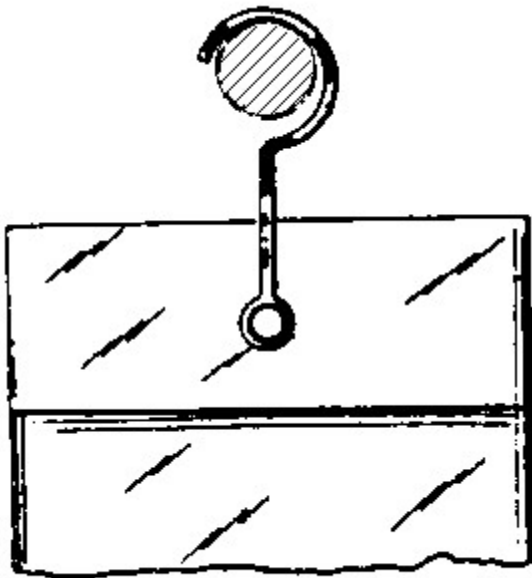
**References****Limiting references***This place does not cover:*

Large flexible containers with lifting loops or similar	B65D 88/16
Devices for suspending handbags from tables, chairs or the like	A47G 29/083
Sack holders, i.e. stands or frames with means for supporting sacks in the open position to facilitate filling with articles or materials	B65B 67/12

Informative references*Attention is drawn to the following places, which may be of interest for search:*

A pair of interconnecting rigid strips made of plastic material	B65D 33/1683
Turn-over flaps co-operating with a separate handle or suspension	B65D 33/246

B65D 33/1608**{Integral flaps for tying above the bag}****Definition statement***This place covers:*

Illustrative example of subject matter classified in this group:

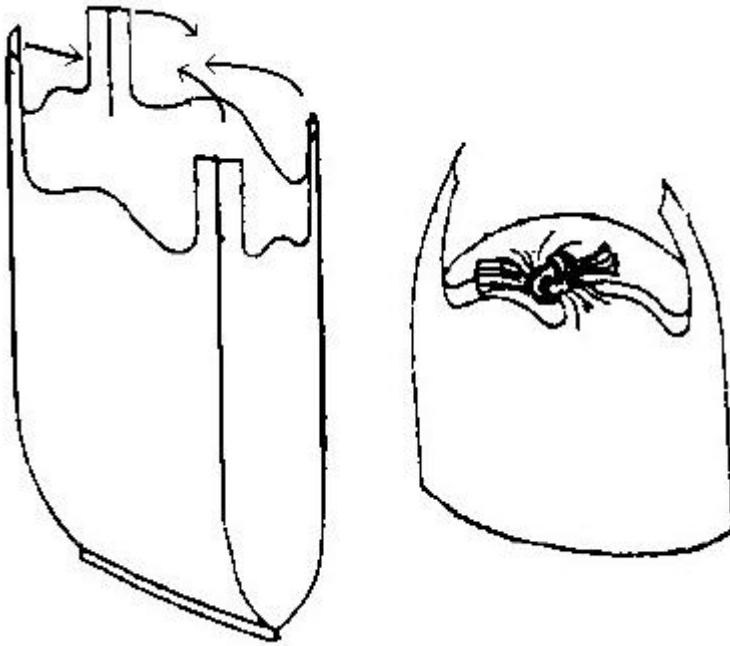
**B65D 33/1616****{Elements constricting the neck of the bag (hinged clips [B65D 33/1675](#))}****References****Limiting references***This place does not cover:*

Applying separate sealing or securing members, e.g. clips, to bags	B65B 51/04
Releasable fastenings clips	F16B 2/20
Tag tickets, or similar identification or indication means to be fastened or secured by the material of the label itself	G09F 3/04

B65D 33/1625

{Small plates or the like made of one piece and presenting slits or a central aperture to jam the neck of the bag}

Definition statement

This place covers:

Illustrative example of subject matter classified in this group:

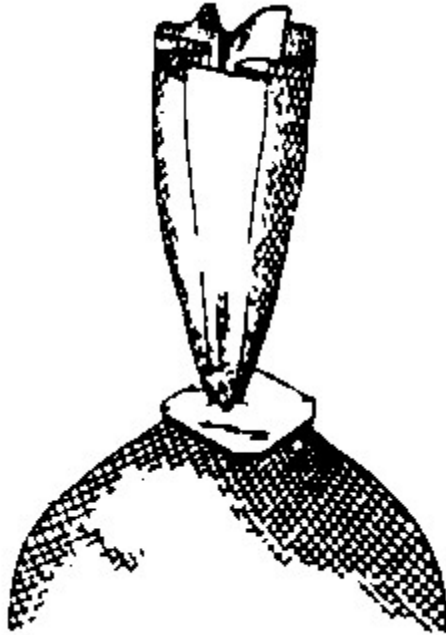
**References****Limiting references**

This place does not cover:

Devices for applying separate sealing or securing members, e.g. clips, to bags	B65B 51/04
Tag tickets, or similar identification or indication means to be fastened or secured by the material of the label itself	G09F 3/04

B65D 33/1633

{Closed rings maintaining the constricted neck around an element, e.g. used as a handle or suspension means, with the element integral or non-integral with the ring}

Definition statement

This place covers:

Illustrative example of subject matter classified in this group:

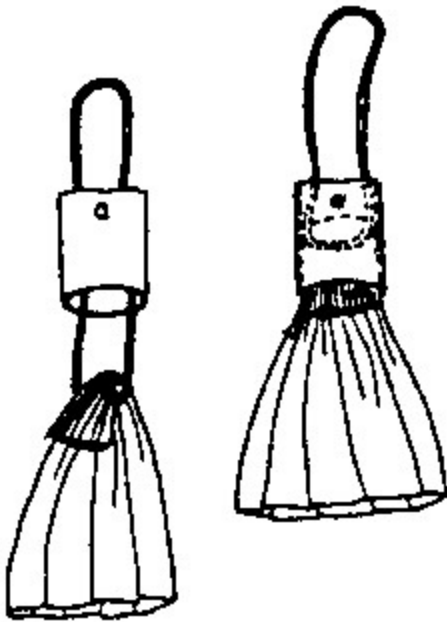
**References****Limiting references**

This place does not cover:

Devices for applying separate sealing or securing members, e.g. clips, to bags	B65B 51/04
--	----------------------------

B65D 33/1641**{Staples, clips or clamps made of metal}****Definition statement***This place covers:*

Illustrative example of subject matter classified in this group:

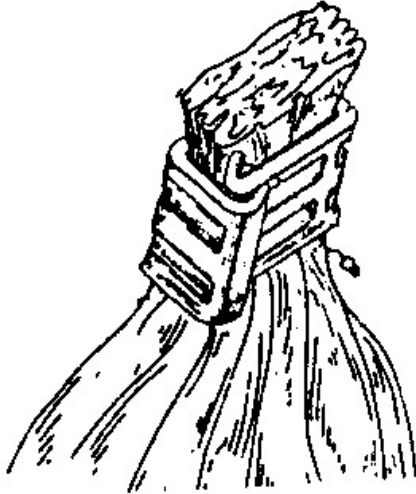
**References****Limiting references***This place does not cover:*

For clamps made of metal	B65D 63/06 , B65D 63/14
Devices for applying separate sealing or securing members, e.g. clips, to bags	B65B 51/04
Releasable fastenings clips	F16B 2/20

B65D 33/165

{Flexible elongated elements integral with or attached to bags or sacks (draw closures [B65D 33/28](#)); Fastening thereof to the bag before closing}

Definition statement

This place covers:

Illustrative example of subject matter classified in this group:

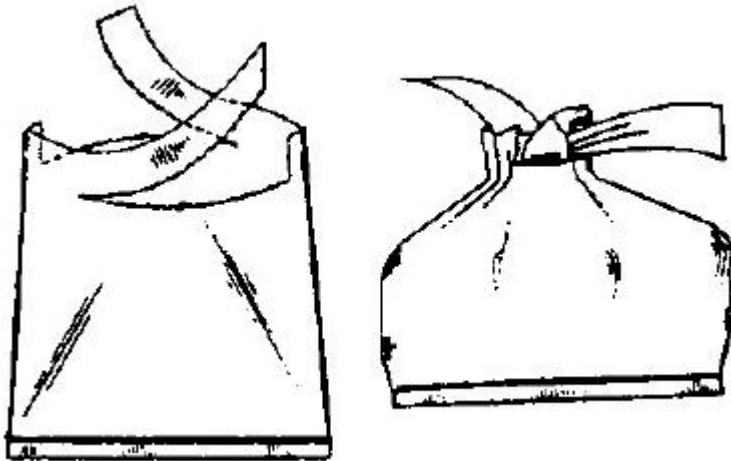
**References****Limiting references**

This place does not cover:

Deformable or resilient metal or like strips or bands	B65D 33/30
Flexible elements per se	B65D 63/00
Devices for applying separate sealing or securing members, e.g. clips, to bags	B65B 51/04

B65D 33/1658

{Elements for flattening or folding the mouth portion ([B65D 33/30](#) takes precedence)}

References**Limiting references**

This place does not cover:

Deformable or resilient metal or like strips or bands	B65D 33/30
---	----------------------------

Informative references

Attention is drawn to the following places, which may be of interest for search:

Flexible containers having several compartments separated by a common rupturable seal	B65D 81/3266
---	------------------------------

B65D 33/1666

{Slitted tubes with or without a core; U-shaped clips made of one piece}

Definition statement

This place covers:

Illustrative example of subject matter classified in this group:

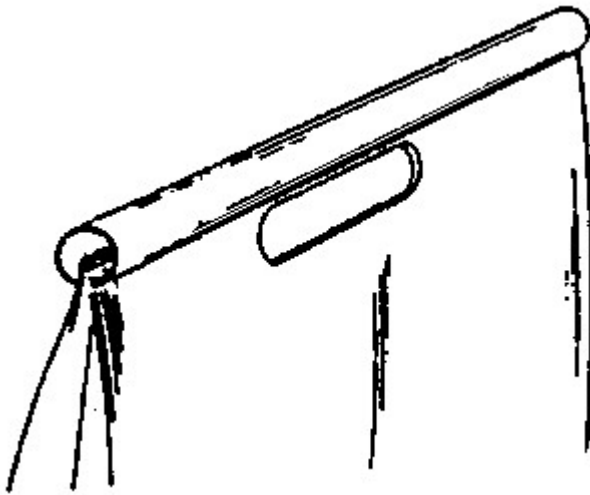
**B65D 33/1675**

{Hinged clips}

Definition statement

This place covers:

Illustrative example of subject matter classified in this group:

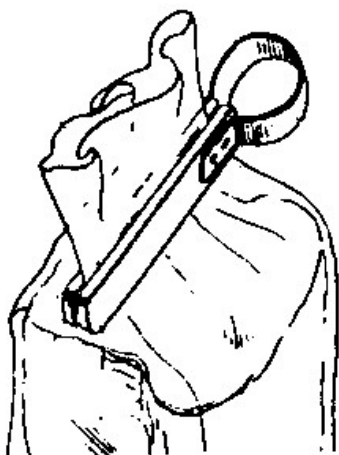
**References****Limiting references**

This place does not cover:

Clothes pegs	D06F 55/00
--------------	----------------------------

Releasable fastenings clips

F16B 2/20

B65D 33/1683

{A pair of interconnecting rigid strips made of plastic material, e.g. one or both being provided with a handle or suspension means}

Definition statement

This place covers:

Illustrative example of subject matter classified in this group:

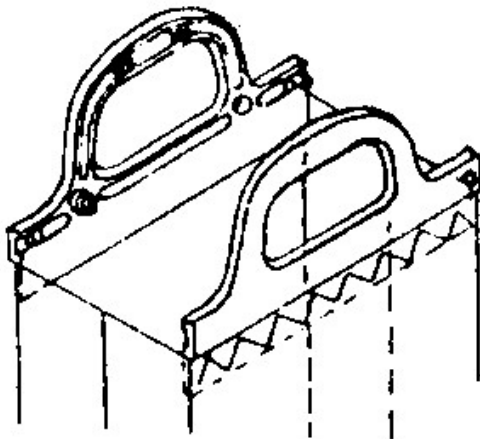

References

Informative references

Attention is drawn to the following places, which may be of interest for search:

Riveting; Dovetailing; Screwing; using press buttons or slide fasteners

B65D 33/25

B65D 33/1691

{using adhesive applied to attached closure elements}

Definition statement

This place covers:

Illustrative example of subject matter classified in this group:

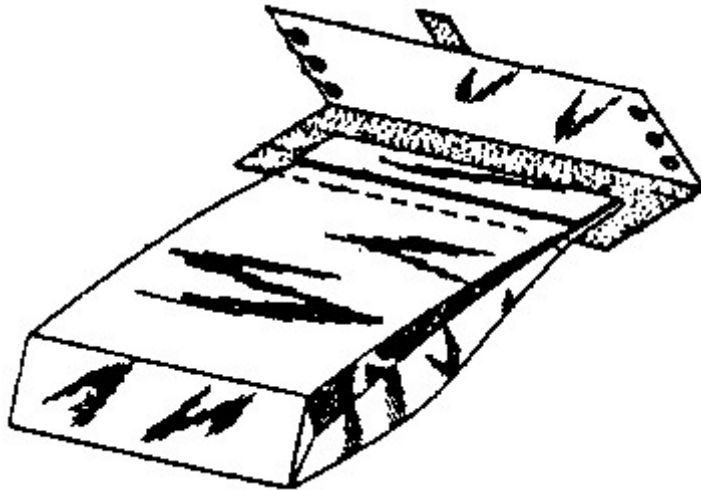

References

Informative references

Attention is drawn to the following places, which may be of interest for search:

Using adhesive applied to integral parts, e.g. to flaps	B65D 33/18
---	----------------------------

B65D 33/18

using adhesive applied to integral parts, e.g. to flaps

Definition statement

This place covers:

Illustrative example of subject matter classified in this group:

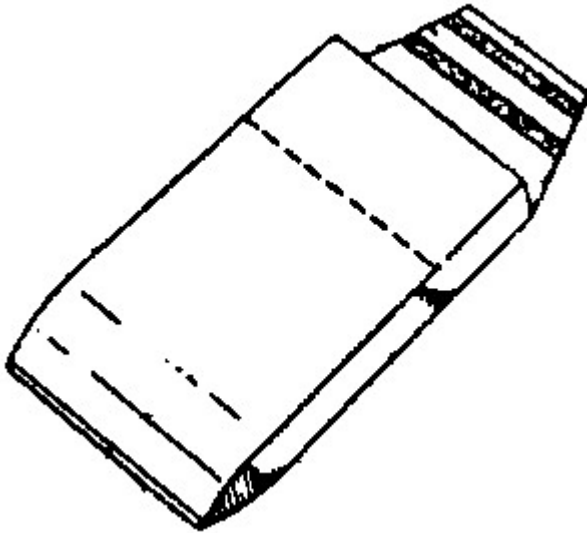

B65D 33/20

using pressure-sensitive adhesive

Definition statement

This place covers:

Illustrative example of subject matter classified in this group:

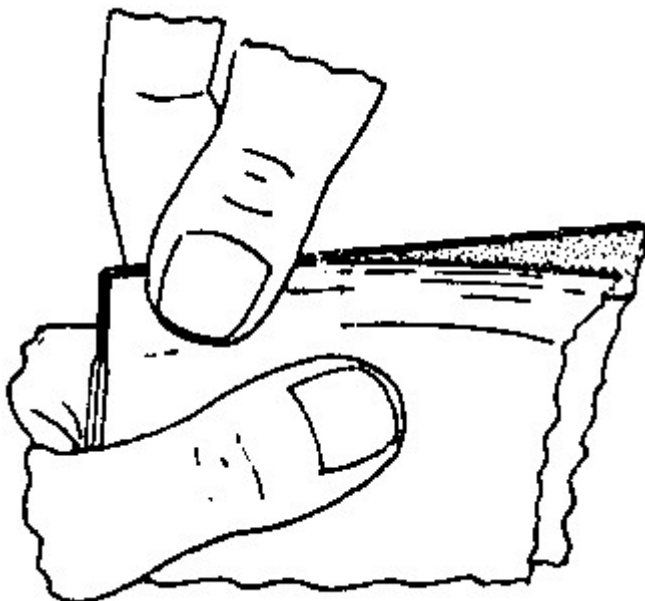

B65D 33/22

using heat-activatable adhesive

Definition statement

This place covers:

Illustrative example of subject matter classified in this group:

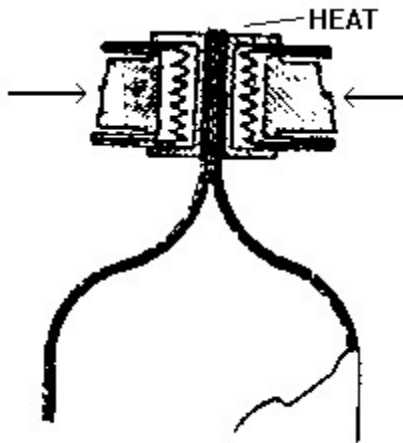

B65D 33/24

using self-locking integral or attached closure elements, e.g. flaps ([B65D 33/25](#) takes precedence)

Definition statement

This place covers:

Illustrative example of subject matter classified in this group:

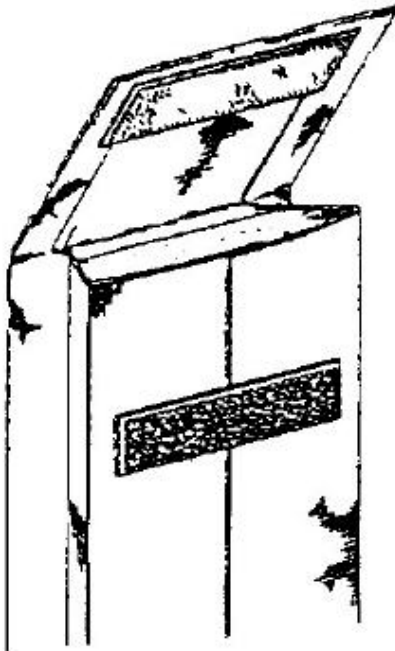
**References****Limiting references**

This place does not cover:

Riveting; Dovetailing; Screwing; Using press buttons or slide fasteners	B65D 33/25
---	----------------------------

Informative references

Attention is drawn to the following places, which may be of interest for search:

Force of static electricity; Two resilient self-closing bands	B65D 33/30
Hook-and-loop fastener bands	B65D 2313/02
Magnetic	B65D 2313/04

Special rules of classification

The use of available Indexing Codes is mandatory.

B65D 33/243

{Combination of flaps, slits, tongues or apertures, e.g. apertures serving as hand or finger holes}

Definition statement

This place covers:

Illustrative example of subject matter classified in this group:

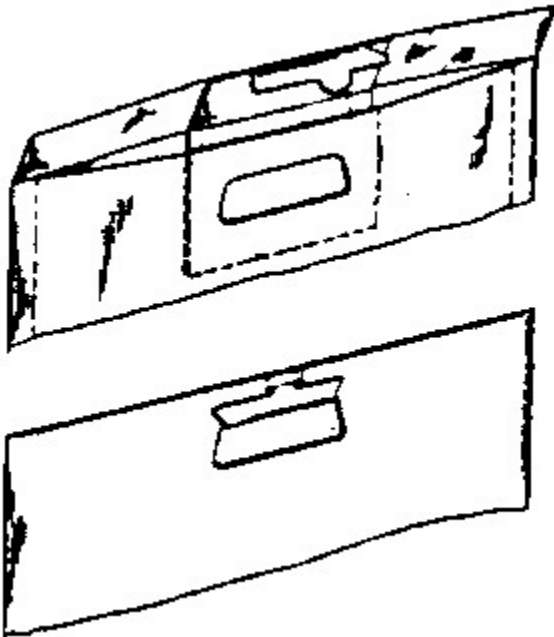

B65D 33/246

{Turn-over flaps co-operating with a separate handle or suspension means}

Definition statement

This place covers:

Illustrative example of subject matter classified in this group:

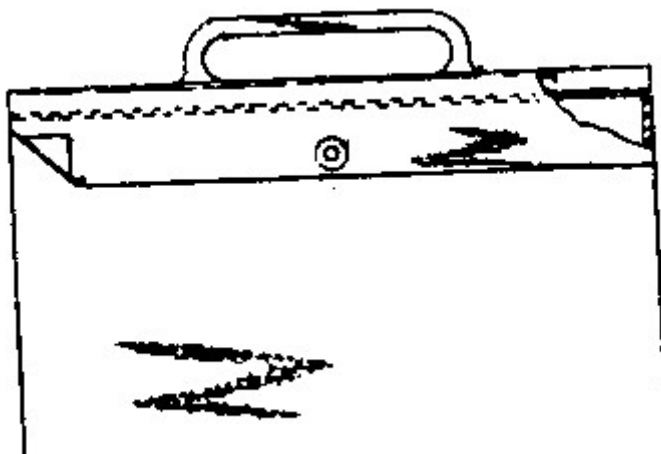

B65D 33/25**Riveting; Dovetailing; Screwing; using press buttons or slide fasteners****References****Informative references***Attention is drawn to the following places, which may be of interest for search:*

A pair of interconnecting rigid strips made of plastic material	B65D 33/1683
Body construction with linings or inserts for keeping body in rolled state after partial expulsion of contents	B65D 35/18
Body construction with the tubular container being provided on its internal surfaces with press buttons or the like for maintaining the container in compressed state	B65D 35/247

B65D 33/2508**{using slide fasteners with interlocking members having a substantially uniform section throughout the length of the fastener; Sliders therefor}****Definition statement***This place covers:*

The use of a slide fastener as end or aperture closing arrangements or devices for sacks or bags, whereby the slide fastener is characterized by a pair of elongated interlocking members which are closed by a sliding action, either manually or by using a slider.

Illustrative example of subject matter classified in this group:

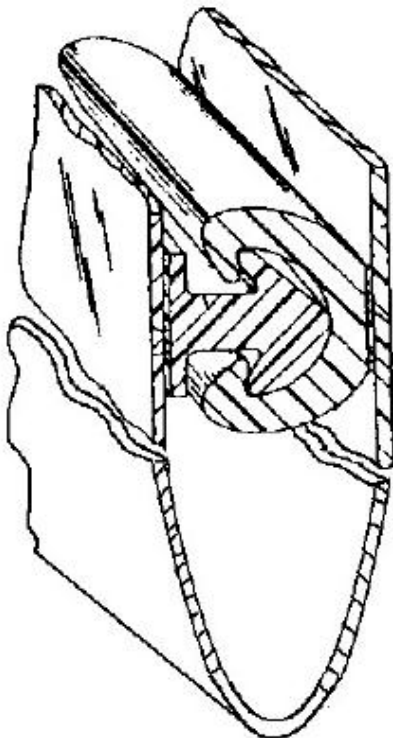

References

Informative references

Attention is drawn to the following places, which may be of interest for search:

Slide fasteners per se	A44B 19/00
Making of slide fasteners	B29D 5/00 , B29L 2005/00
Making reclosable bags with interengaging elements	B31B 70/81 , B31B 2160/10
Applying profile strips to bags	B65B 61/188

B65D 33/2516

{comprising tamper-indicating means, e.g. located within the fastener (provided in the slider [B65D 33/2585](#))}

Definition statement

This place covers:

Illustrative example of subject matter classified in this group:

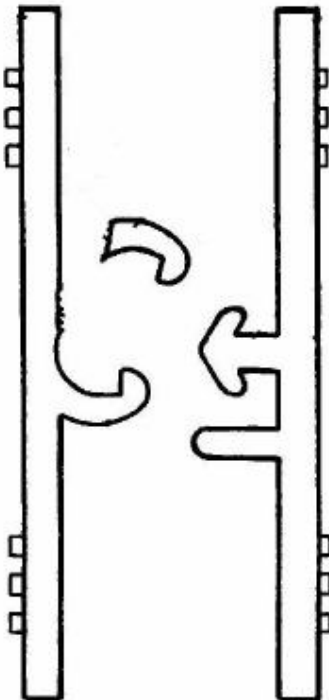

References

Limiting references

This place does not cover:

Tamper-indicating means provided in the slider	B65D 33/2585
--	------------------------------

B65D 33/2525

{located between the fastener and the product compartment}

Definition statement

This place covers:

Illustrative example of subject matter classified in this group:

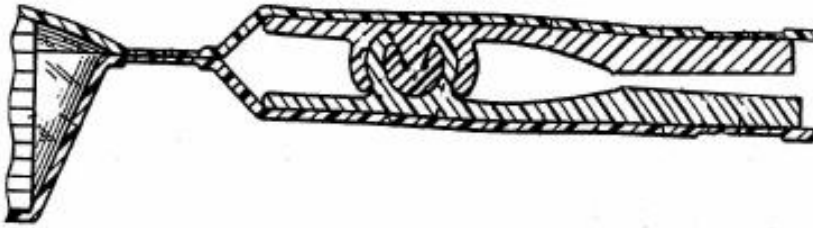

B65D 33/2533

{the slide fastener being located between the product compartment and the tamper indicating means}

Definition statement

This place covers:

Illustrative example of subject matter classified in this group:

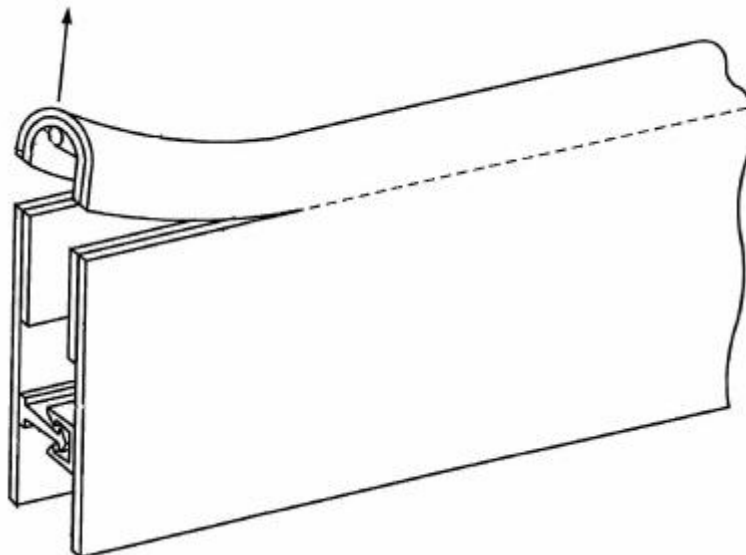

B65D 33/255

{being provided with special visual, audible or tactile indicating means, e.g. indicating proper engagement ([B65D 33/2516](#) takes precedence)}

Definition statement

This place covers:

Illustrative example of subject matter classified in this group:

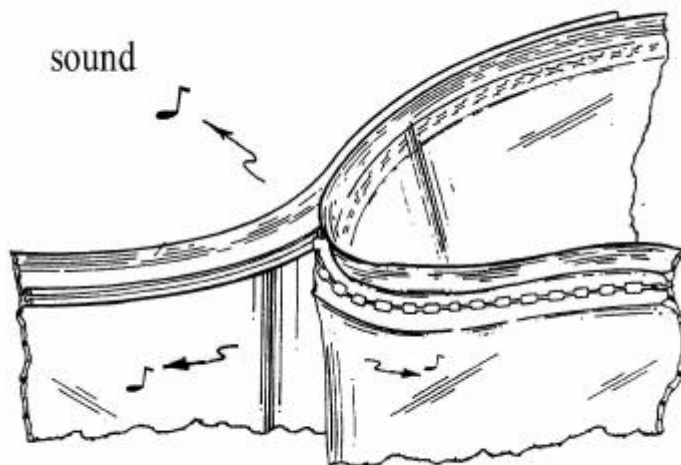
**References****Limiting references**

This place does not cover:

Comprising tamper-indicating means	B65D 33/2516
------------------------------------	------------------------------

Informative references

Attention is drawn to the following places, which may be of interest for search:

Audible olfactory or visual signalling means	B65D 2203/12
--	------------------------------

B65D 33/2558

{the slide fastener having a non-constant section throughout the length of the fastener, e.g. slightly undulated interlocking members or castellated stringers}

Definition statement

This place covers:

Illustrative example of subject matter classified in this group:

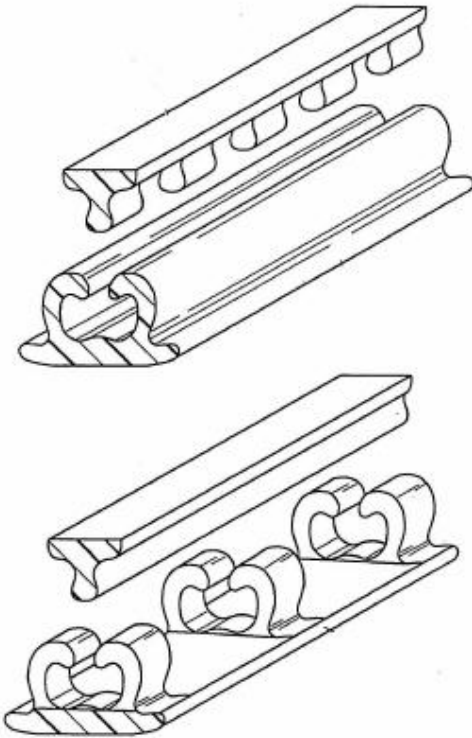

B65D 33/2566

{using two or more independently operable slide fasteners}

Definition statement

This place covers:

Illustrative example of subject matter classified in this group:



B65D 33/2575

{the slide fastener providing access to the bag through a bag wall, e.g. intended to be cut open by the consumer}

Definition statement

This place covers:

Illustrative example of subject matter classified in this group:

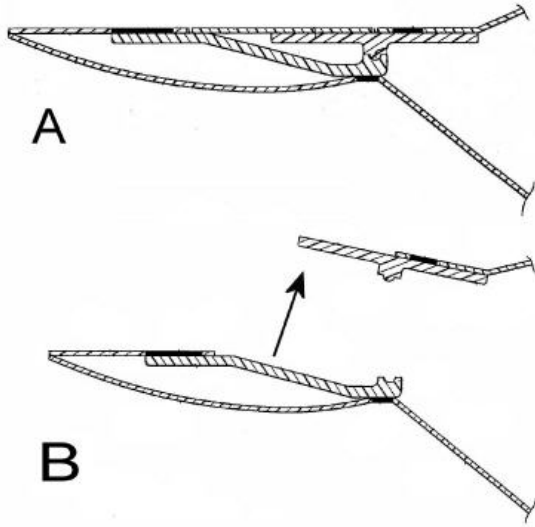
**B65D 33/2583**

{the slide fastener being attached to one wall only}

Definition statement

This place covers:

Illustrative example of subject matter classified in this group:

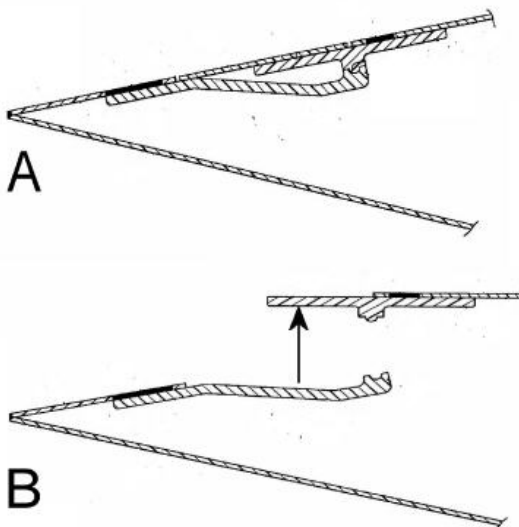

B65D 33/2585**{being provided with tamper-indicating means}****Definition statement***This place covers:*

Illustrative example of subject matter classified in this group.

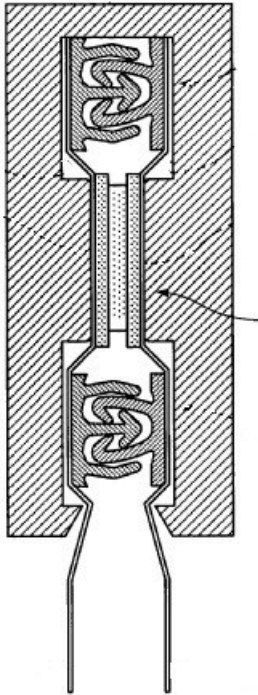
**References*****Informative references****Attention is drawn to the following places, which may be of interest for search:*

With special means for indicating unauthorized opening	B65D 33/34
--	----------------------------

B65D 33/2586

{being provided with a separating plow}

Definition statement

This place covers:

Illustrative example of subject matter classified in this group.

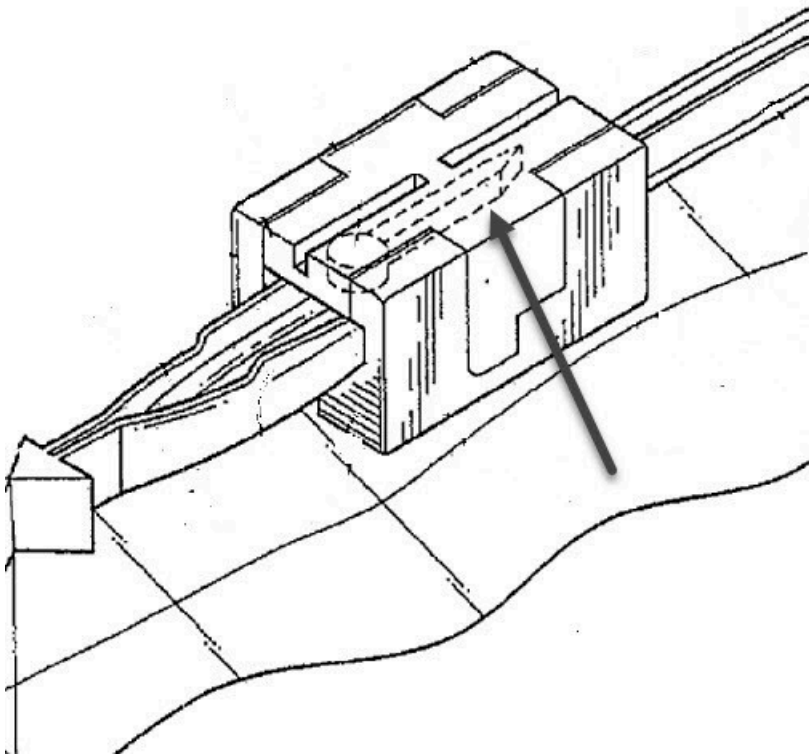

B65D 33/25865

{reaching between the interlocking fastener profiles}

Definition statement

This place covers:

Illustrative example of subject matter classified in this group.

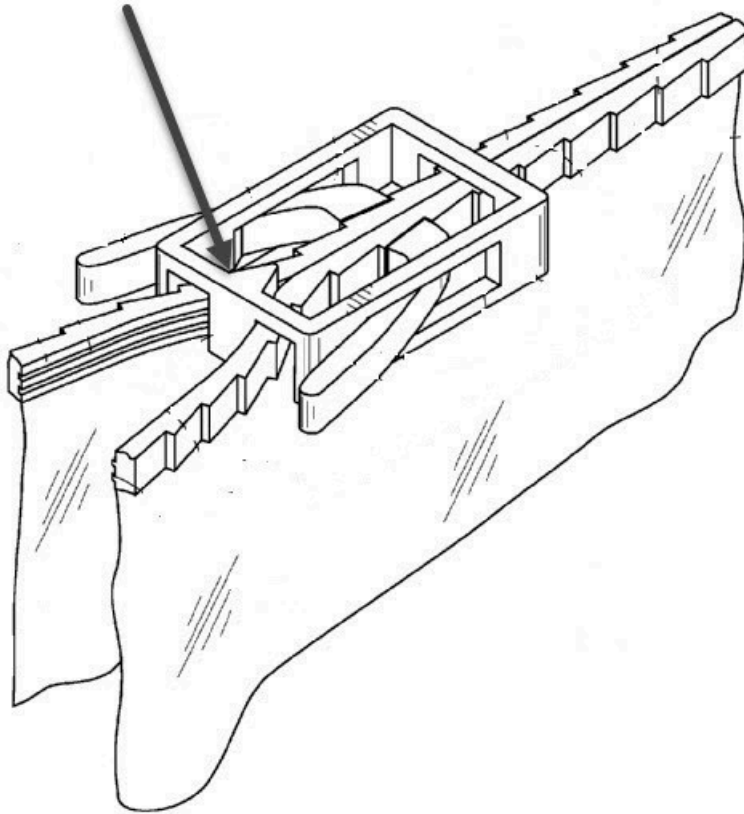

B65D 33/2587

{the slider being made out of a plurality of pieces}

Definition statement

This place covers:

Illustrative example of subject matter classified in this group.

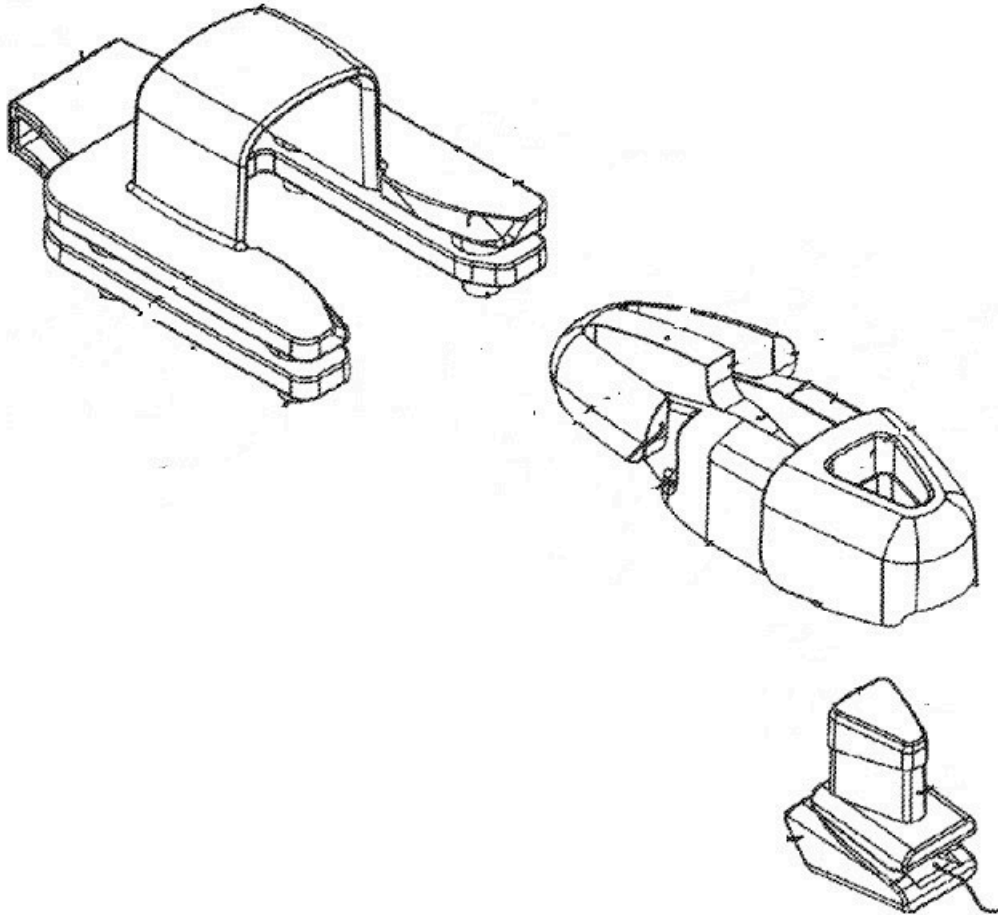

B65D 33/2588

{being provided with flexing or moving parts}

Definition statement

This place covers:

Illustrative example of subject matter classified in this group.

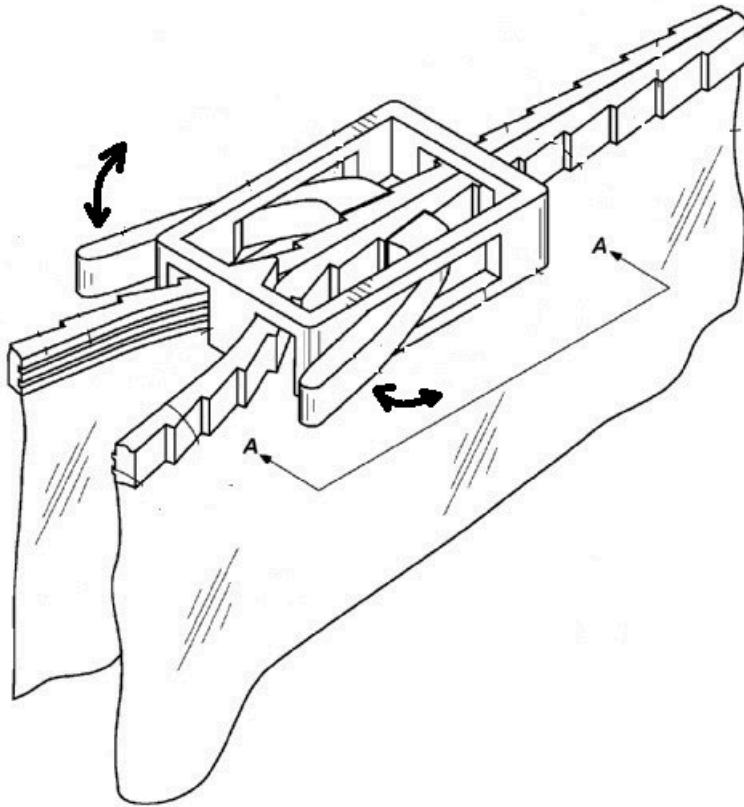

B65D 33/2589

{Bag or slide fastener details cooperating with the slider, e.g. details for removing or installing the slider}

Definition statement

This place covers:

Illustrative example of subject matter classified in this group.

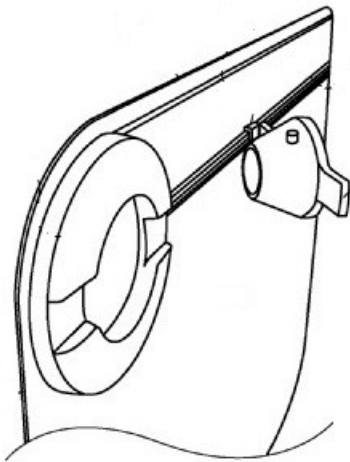
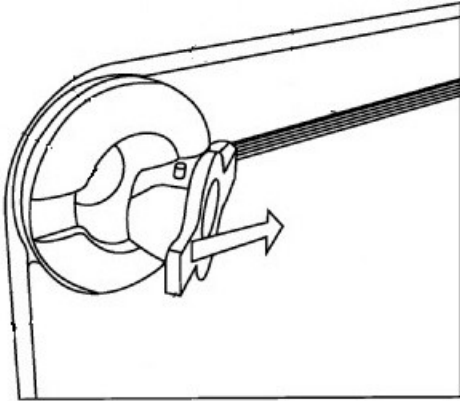

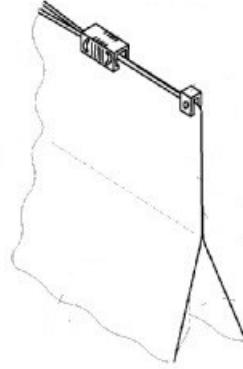
B65D 33/259**{End stops}****Definition statement***This place covers:*

Illustrative example of subject matter classified in this group.

B65D 33/26**using staples or stitches {(B65D 33/1641 takes precedence)}****Definition statement***This place covers:*

Illustrative example of subject matter classified in this group:

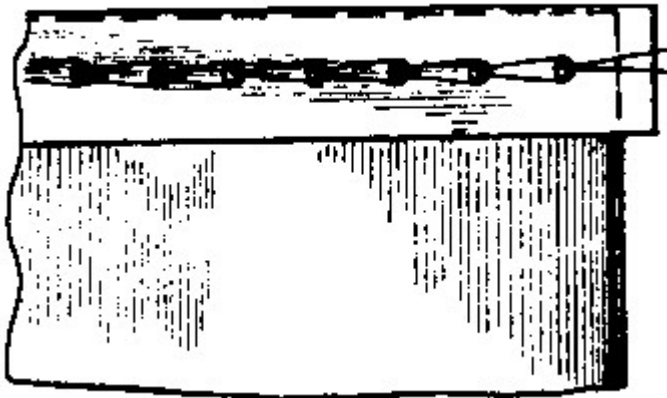
**References****Limiting references***This place does not cover:*

Staples, clips or clamps made of metal	B65D 33/1641
--	------------------------------

B65D 33/28

Strings or strip-like closures {, i.e. draw closures}

Definition statement

This place covers:

Illustrative example of subject matter classified in this group:

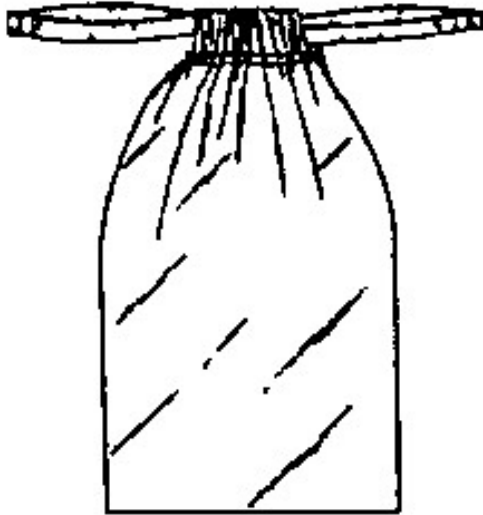

B65D 33/30

Deformable or resilient metal or like strips or bands {(B65D 33/1616 takes precedence)}

Definition statement

This place covers:

Illustrative example of subject matter classified in this group:

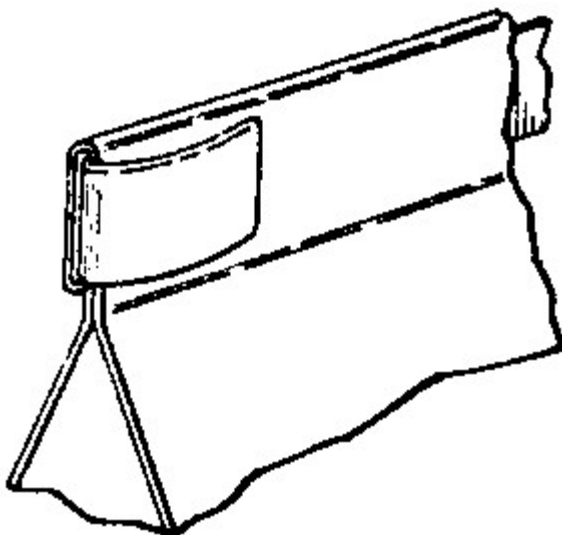

References

Limiting references

This place does not cover:

Elements constricting the neck of the bag	B65D 33/1616
---	------------------------------

Informative references

Attention is drawn to the following places, which may be of interest for search:

Joints produced by deformation or tying of ends of elements	B65D 63/12
---	----------------------------

B65D 33/32

Metallic chain closures

Definition statement

This place covers:

Illustrative example of subject matter classified in this group:

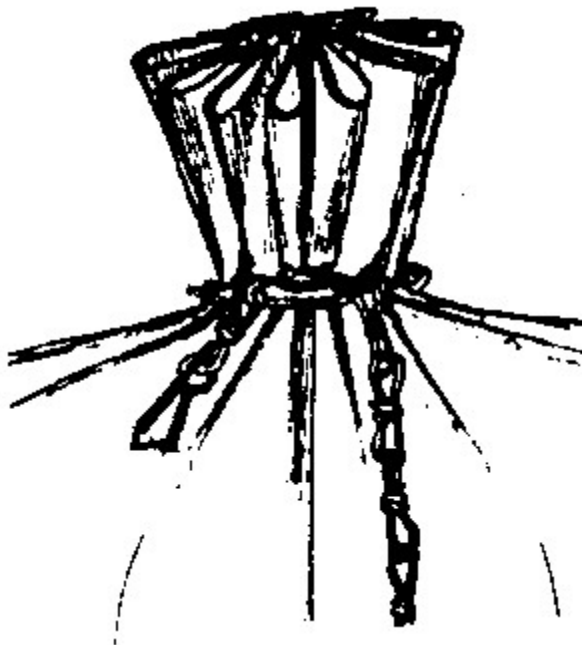

B65D 33/34

with special means for indicating unauthorised opening {([B65D 33/2516](#), [B65D 33/2585](#) take precedence)}

Definition statement

This place covers:

Illustrative example of subject matter classified in this group:

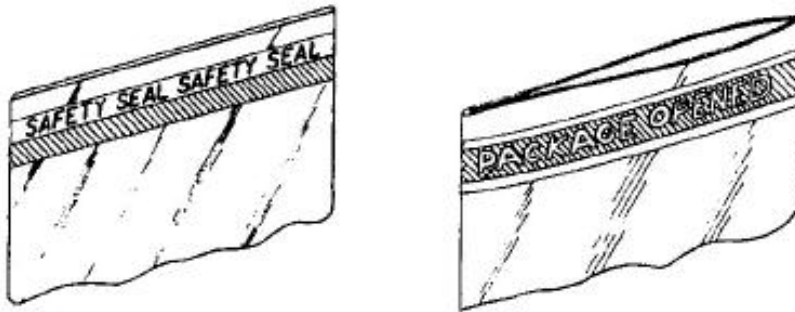
**References****Limiting references**

This place does not cover:

Comprising tamper-indicating means	B65D 33/2516
------------------------------------	------------------------------

Informative references

Attention is drawn to the following places, which may be of interest for search:

End- or aperture-closing arrangements using riveting, dovetailing, screwing press buttons or slide fasteners and comprising tamper-indicating means	B65D 33/2516
Slider being provided with tamper-indicating means	B65D 33/2585

B65D 35/04

made in one piece

Definition statement

This place covers:

Illustrative example of subject matter classified in this group:

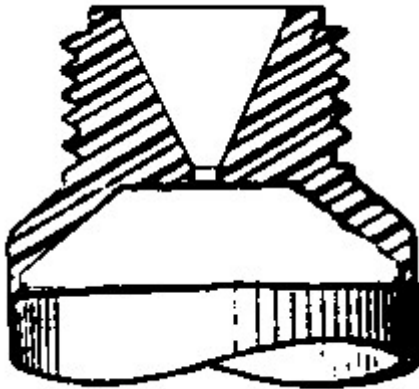

B65D 35/10

made by uniting or interconnecting two or more components

Definition statement

This place covers:

Illustrative example of subject matter classified in this group:

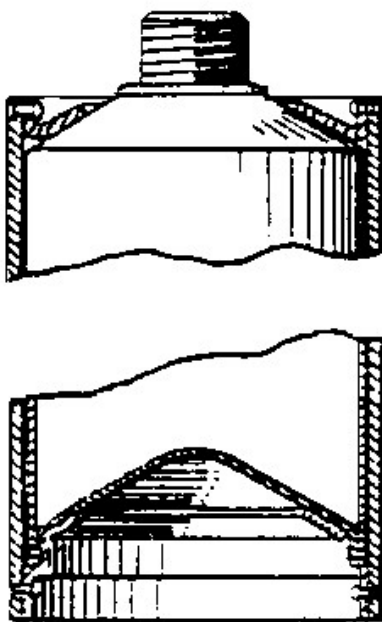

B65D 35/12

Connections between body and closure-receiving bush

Definition statement

This place covers:

Illustrative example of subject matter classified in this group:

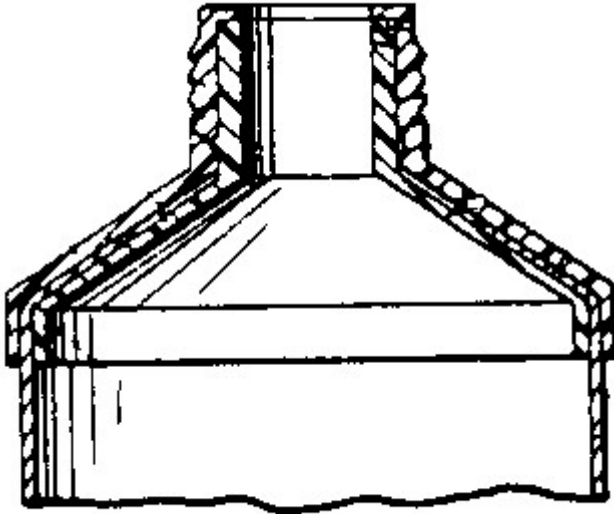

B65D 35/14**with linings or inserts****Definition statement***This place covers:*

Illustrative example of subject matter classified in this group:

**References*****Informative references****Attention is drawn to the following places, which may be of interest for search:*

Single-unit hand-held apparatus characterised by the container	B05B 11/048
--	-----------------------------

B65D 35/18

for keeping body in rolled state after partial expulsion of contents

Definition statement

This place covers:

Illustrative example of subject matter classified in this group:

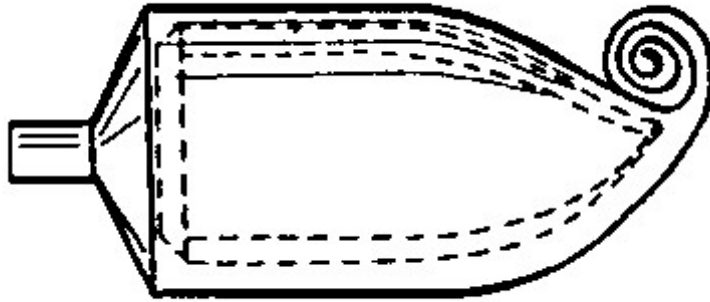
**References****Informative references**

Attention is drawn to the following places, which may be of interest for search:

Riveting; Dovetailing; Screwing; using press buttons or slide fasteners	B65D 33/25
The tubular container being provided on its internal surfaces with press buttons or the like for maintaining the container in a suppressed state	B65D 35/247

B65D 35/20

for retracting contents

Definition statement

This place covers:

Illustrative example of subject matter classified in this group:

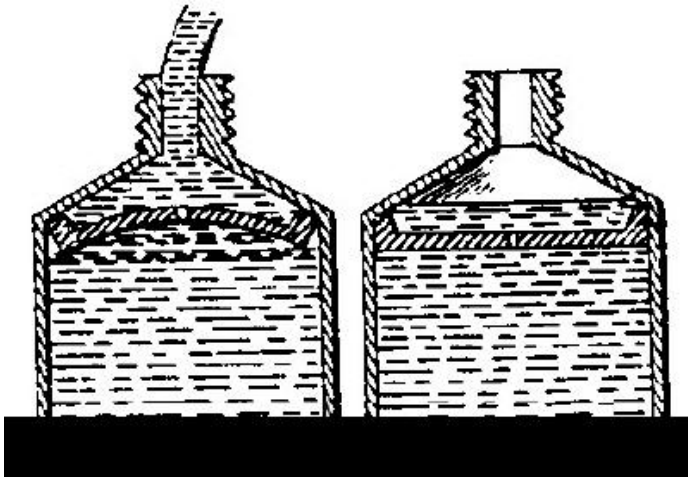

B65D 35/22

with two or more compartments

Definition statement

This place covers:

Illustrative example of subject matter classified in this group:

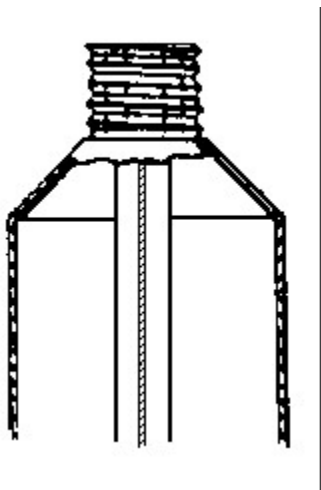

References

Informative references

Attention is drawn to the following places, which may be of interest for search:

Rigid containers disposed one within the other arranged parallel or concentrically and permitting simultaneous dispensing of the two materials without prior mixing	B65D 81/3227
Flexible containers disposed within rigid containers arranged parallel or concentrically and permitting simultaneous dispensing of the two materials without prior mixing	B65D 81/3244

B65D 35/24

with auxiliary devices (linings or inserts [B65D 35/14](#))

References

Limiting references

This place does not cover:

Spoon-shaped dispensing spouts	B65D 51/246 , B65D 77/245
Spoon-shaped dispensing spouts for administering medicine	A61J 7/0015

B65D 35/242

{for mixing or discharging of two or more components}

Definition statement

This place covers:

Illustrative example of subject matter classified in this group:

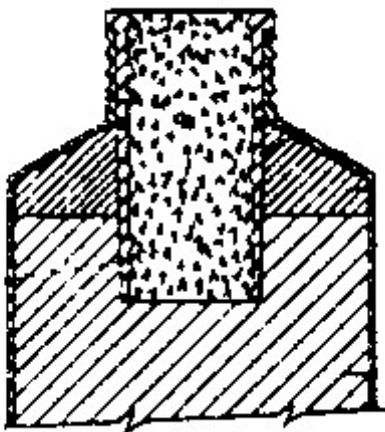

References

Informative references

Attention is drawn to the following places, which may be of interest for search:

Closures not otherwise provided for, with auxiliary containers for additional articles or materials	B65D 51/28
---	----------------------------

B65D 35/245

{Suspension means integral with, or attached to the container ([B65D 51/242](#) takes precedence)}

Definition statement

This place covers:

Illustrative example of subject matter classified in this group:



References

Informative references

Attention is drawn to the following places, which may be of interest for search:

Suspension means	B65D 23/003
HOLDERS for collapsible tubes	B65D 35/56

B65D 35/247

{the tubular container being provided on its internal surfaces with press buttons or the like for maintaining the container in compressed state}

Definition statement

This place covers:

Illustrative example of subject matter classified in this group:

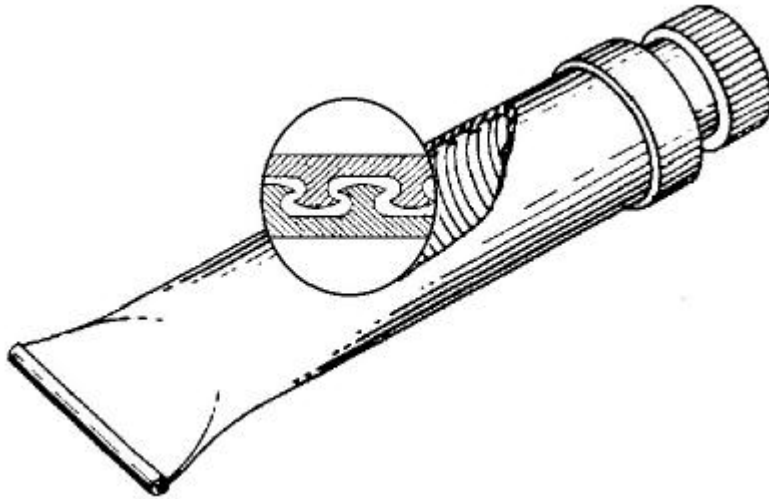
**References****Informative references**

Attention is drawn to the following places, which may be of interest for search:

Riveting; Dovetailing; Screwing; using press buttons or slide fasteners	B65D 33/25
Body construction for keeping body in rolled state after partial expulsion of contents	B65D 35/18

B65D 35/26**for filling****Definition statement***This place covers:*

Illustrative example of subject matter classified in this group:

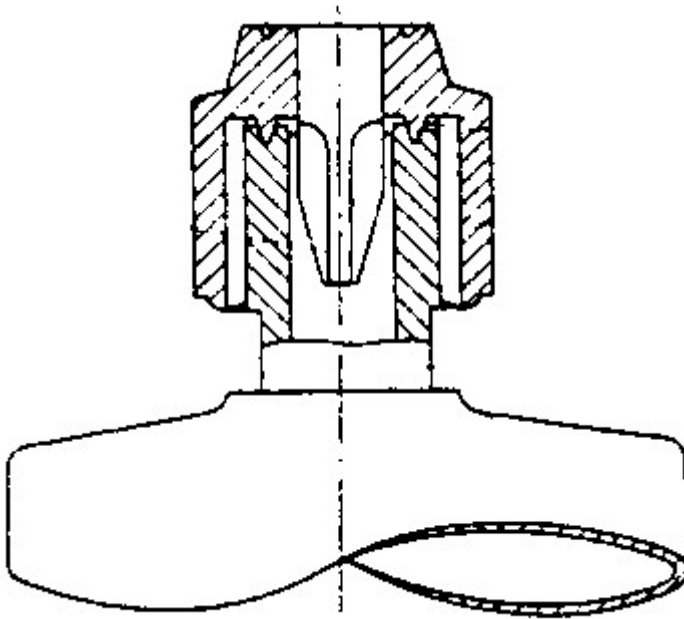
**B65D 35/28****for expelling contents****References****Limiting references***This place does not cover:*

Metering discharge	B65D 35/40
Brushes with reservoir or other means for applying substances, e.g. paints, pastes, water,	A46B 11/00

B65D 35/285**{Co-operating squeezing supporting rollers}****Definition statement***This place covers:*

Illustrative example of subject matter classified in this group:

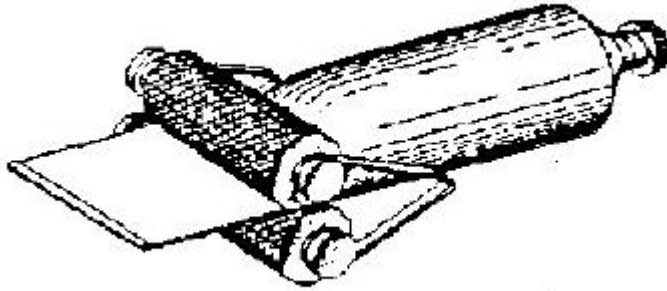
**B65D 35/30****Pistons****Definition statement***This place covers:*

Illustrative example of subject matter classified in this group:

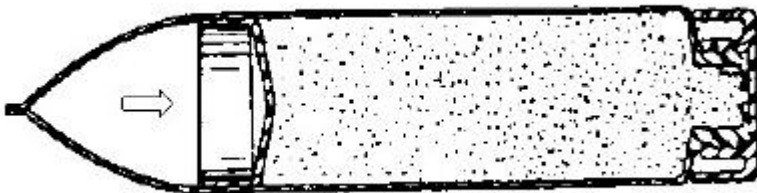
**References****Informative references***Attention is drawn to the following places, which may be of interest for search:*

Containers or packages provided with a piston or with a movable bottom or partition having approximately the same section as the container	B65D 83/0005
--	------------------------------

B65D 35/32

Winding keys

Definition statement

This place covers:

Illustrative example of subject matter classified in this group:

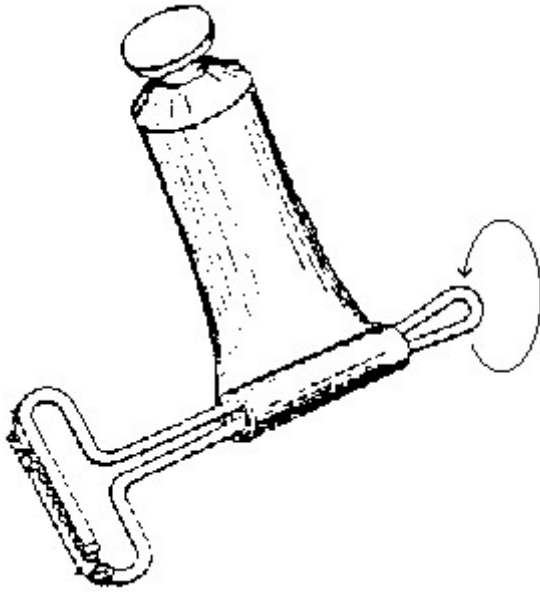

B65D 35/34

connected to, or associated with, tube holders

Definition statement

This place covers:

Illustrative example of subject matter classified in this group:

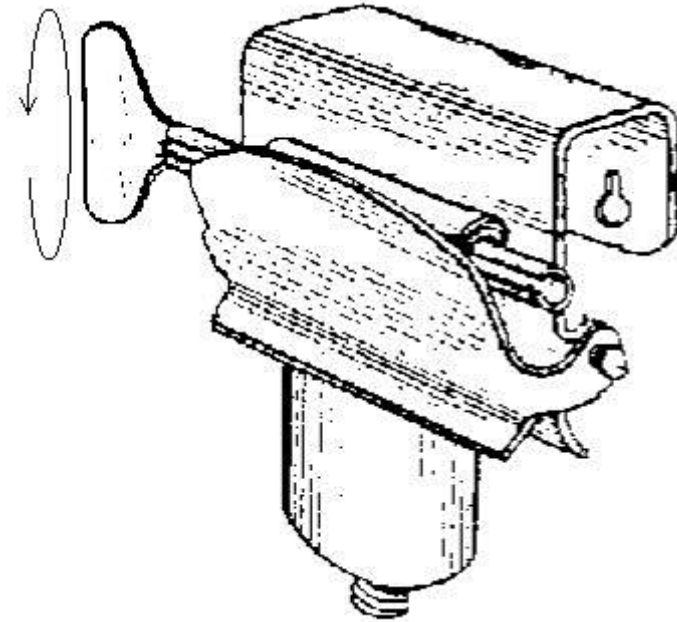

B65D 35/36

for applying contents to surfaces (brushes combined or associated with tubular containers [A46B 11/00](#))

Definition statement

This place covers:

Illustrative example of subject matter classified in this group:

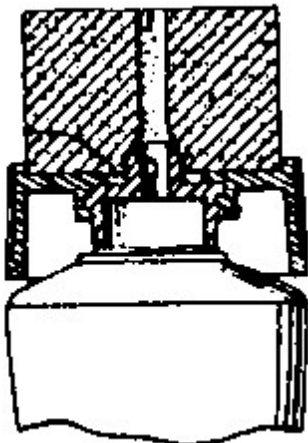

References

Informative references

Attention is drawn to the following places, which may be of interest for search:

Closures with filling and discharging, or with discharging, devices with pads or like contents-applying means	B65D 47/42
---	----------------------------

B65D 35/38

Nozzles

Definition statement

This place covers:

Illustrative example of subject matter classified in this group:

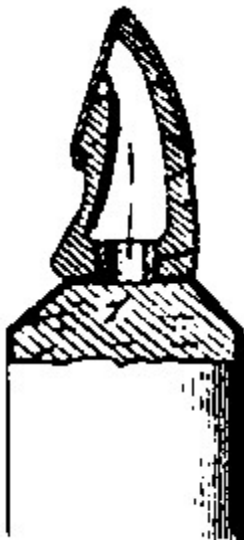

B65D 35/40

for metering discharge

Definition statement

This place covers:

Illustrative example of subject matter classified in this group:

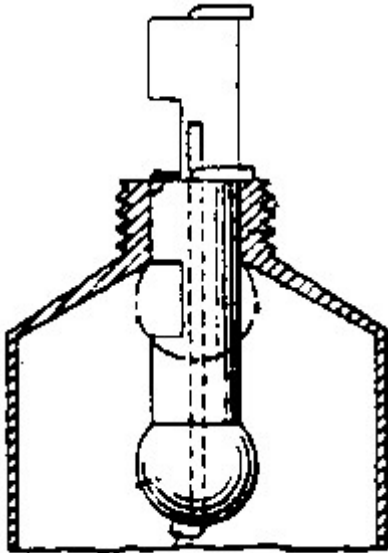

B65D 35/42

for preventing loss of removable closure members

Definition statement

This place covers:

Illustrative example of subject matter classified in this group:

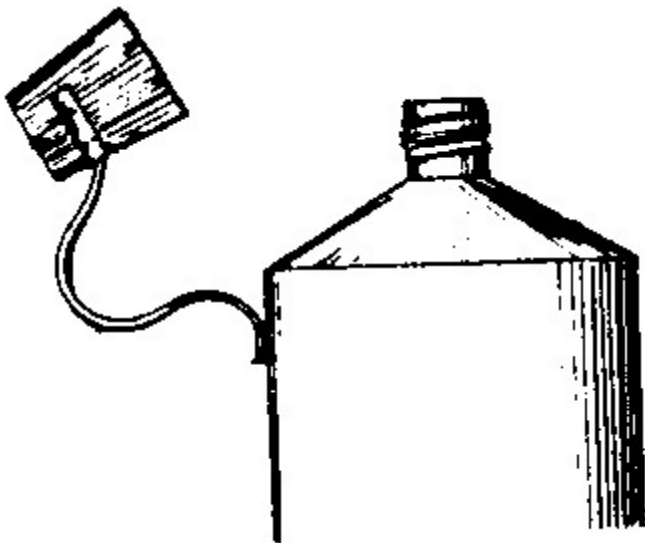

References

Informative references

Attention is drawn to the following places, which may be of interest for search:

Devices preventing loss of removable closure members	B65D 55/16
--	----------------------------

B65D 35/56

Holders for collapsible tubes {([B65D 51/249](#) takes precedence)}

Definition statement

This place covers:

Illustrative example of subject matter classified in this group:

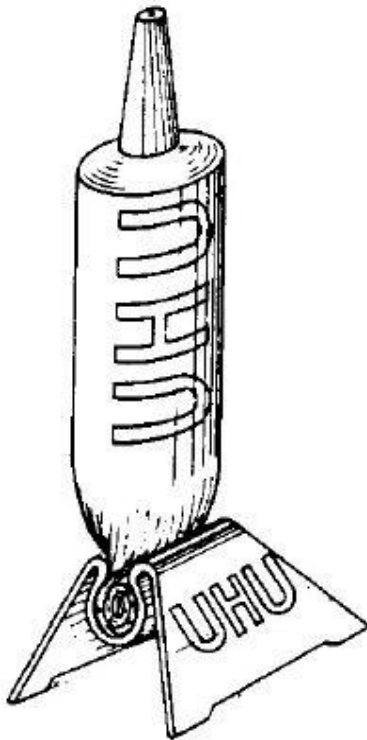

References

Limiting references

This place does not cover:

Suspension means	B65D 35/245
Discharge	B65D 35/28 , B65D 35/40
The closure being specifically formed for supporting the container	B65D 51/249

Informative references

Attention is drawn to the following places, which may be of interest for search:

The closure being specifically formed for supporting the container	B65D 51/249
--	-----------------------------

B65D 35/565

{the holder being attached to a wall or suspended from a panel ([B65D 35/285](#) takes precedence)}

Definition statement

This place covers:

Illustrative example of subject matter classified in this group:

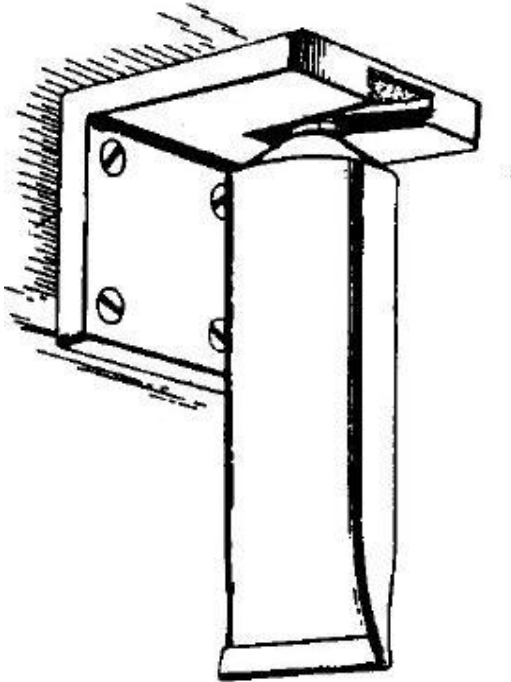
**References****Informative references**

Attention is drawn to the following places, which may be of interest for search:

Dispensers for soap applied by gravitational force	A47K 5/1214
--	-----------------------------

B65D 37/00

Portable flexible containers not otherwise provided for

References**Limiting references**

This place does not cover:

Big flexible bags	B65D 88/16
-------------------	----------------------------

B65D 39/00

Closures arranged within necks or pouring openings or in discharge apertures, e.g. stoppers (lids or covers [B65D 43/00](#); with additional securing elements [B65D 45/00](#))

References

Limiting references

This place does not cover:

Separate closure devices for reclosing opened cans, tins, e.g. beer cans	B65D 51/007
Closure members for apertures in vehicle floors, e.g. plugs	B62D 25/24

Informative references

Attention is drawn to the following places, which may be of interest for search:

Closures to be pierced by an extracting-device for the contents and fixed on the container by separate retaining means	B65D 51/002
--	-----------------------------

B65D 39/0005

{made in one piece ([B65D 39/02](#), [B65D 39/04](#), [B65D 39/06](#), [B65D 39/08](#) take precedence)}

References

Limiting references

This place does not cover:

Disc closures	B65D 39/02
Cup-shaped plugs or like hollow flanged members	B65D 39/04
Balls	B65D 39/06
Threaded or like closure members secured by rotation; Bushes therefor	B65D 39/08

Special rules of classification

The use of available Indexing Codes is mandatory.

B65D 39/0011

{from natural or synthetic cork, e.g. for wine bottles or the like}

Definition statement

This place covers:

Illustrative example of subject matter classified in this group:



Special rules of classification

The use of available Indexing Codes is mandatory.

B65D 39/0017

{Injection-molded plastic closures for "Champagne"- or "Sekt"-type bottles}

Definition statement

This place covers:

Illustrative example of subject matter classified in this group:

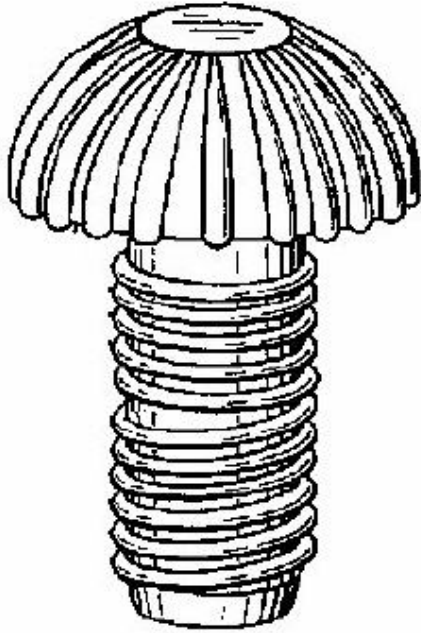

Special rules of classification

The use of available Indexing Codes is mandatory.

B65D 39/0023**{Plastic cap-shaped hollow plugs}****Definition statement***This place covers:*

Illustrative example of subject matter classified in this group:

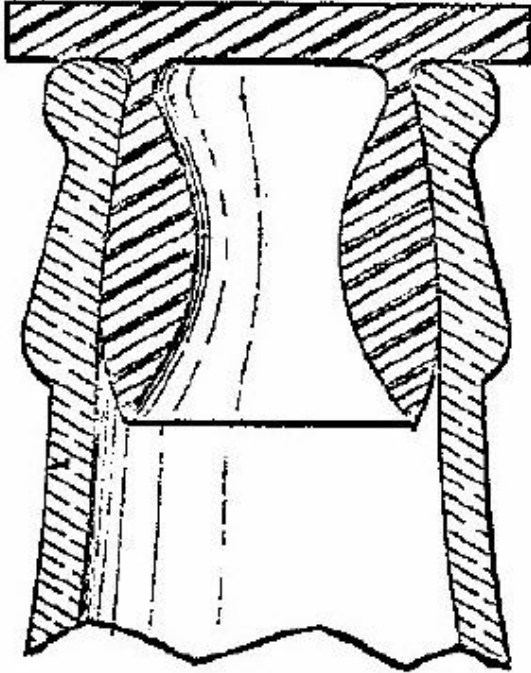
**References****Limiting references***This place does not cover:*

Cup-shaped hollow plugs	B65D 39/04
-------------------------	----------------------------

Special rules of classification

The use of available Indexing Codes is mandatory.

B65D 39/0029

{Plastic closures other than those covered by groups
[B65D 39/0011](#) - [B65D 39/0023](#)}

Definition statement

This place covers:

Illustrative example of subject matter classified in this group:

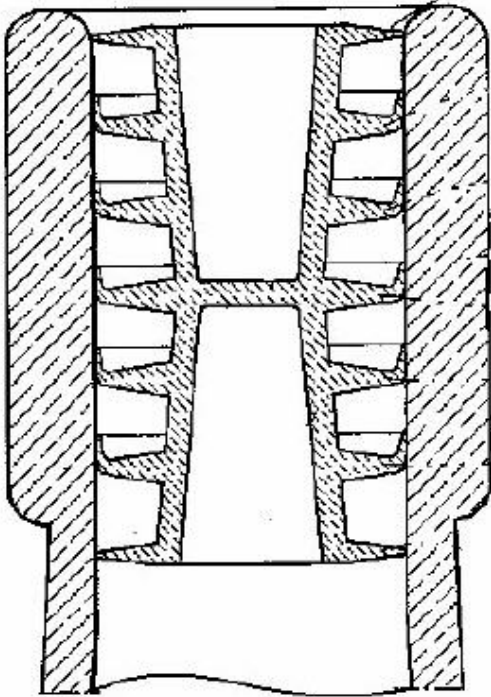

Special rules of classification

The use of available Indexing Codes is mandatory.

B65D 39/0035

{Swing or hinged stoppers, e.g. for "Grolsch"-type bottles (toggle mechanisms [B65D 45/06](#) or [B65D 45/16](#))}

Definition statement

This place covers:

Illustrative example of subject matter classified in this group:

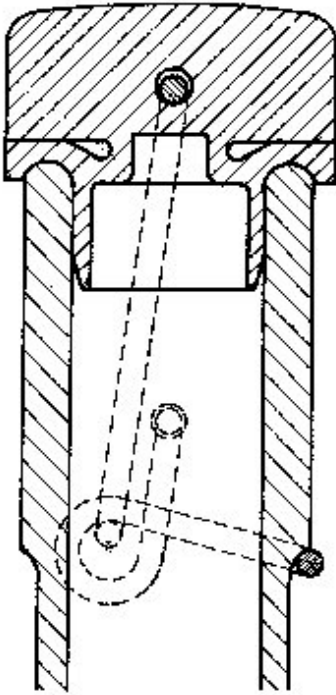

Special rules of classification

The use of available Indexing Codes is mandatory.

B65D 39/0041

{Bungs, e.g. wooden or rubber, for barrels or the like ([B65D 39/08](#) takes precedence)}

Definition statement

This place covers:

Illustrative example of subject matter classified in this group:

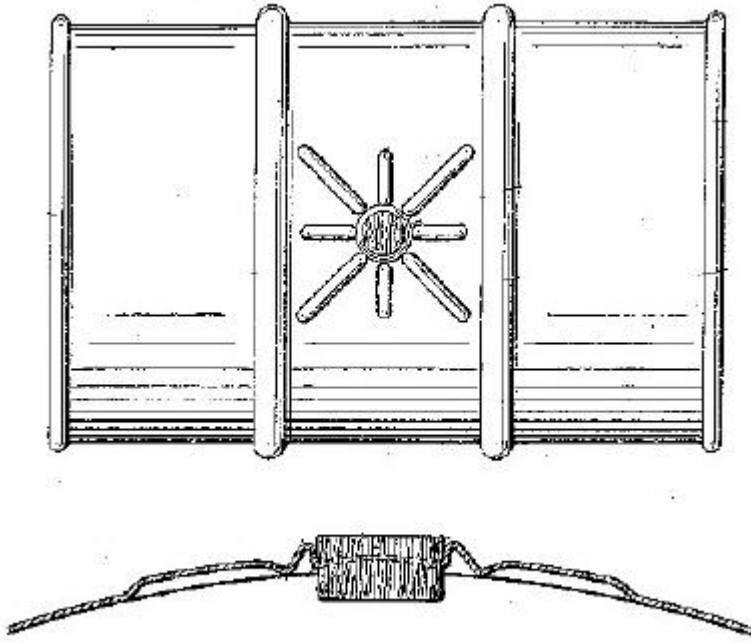

References

Limiting references

This place does not cover:

Threaded or like closure members secured by rotation; Bushes therefor	B65D 39/08
---	----------------------------

Special rules of classification

The use of available Indexing Codes is mandatory.

B65D 39/0047

{Glass, ceramic or metal stoppers for perfume bottles or the like ([B65D 39/0035](#) takes precedence)}

Definition statement

This place covers:

Illustrative example of subject matter classified in this group:

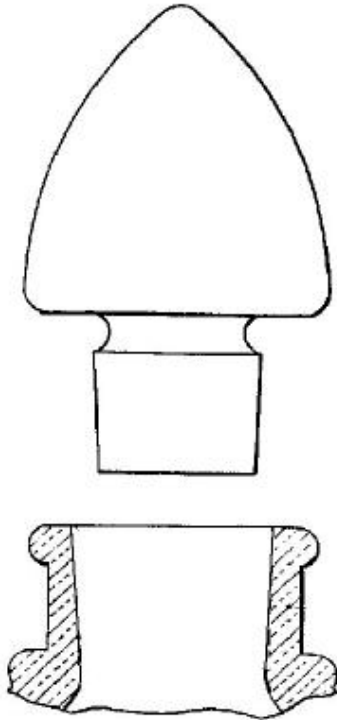
**Special rules of classification**

The use of available Indexing Codes is mandatory.

B65D 39/0052

{made in more than one piece ([B65D 39/02](#), [B65D 39/04](#), [B65D 39/06](#), [B65D 39/08](#) take precedence)}

References**Limiting references**

This place does not cover:

Disc closures	B65D 39/02
Cup-shaped plugs or like hollow flanged members	B65D 39/04
Balls	B65D 39/06
Threaded or like closure members secured by rotation; Bushes therefor	B65D 39/08

Special rules of classification

The use of available Indexing Codes is mandatory.

B65D 39/0058

{from natural or synthetic cork, e.g. for wine bottles or the like}

Definition statement

This place covers:

Illustrative example of subject matter classified in this group:

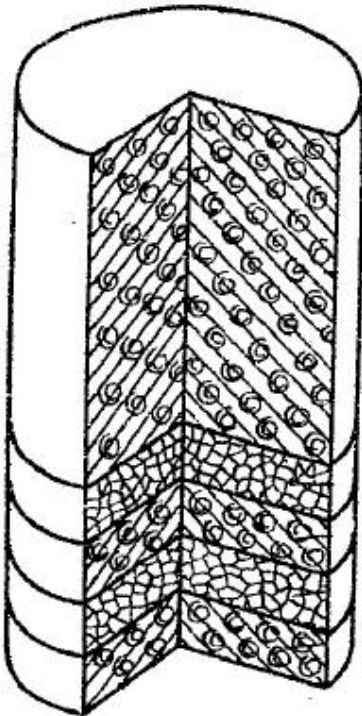
**Special rules of classification**

The use of available Indexing Codes is mandatory.

B65D 39/0064

{Injection-molded plastic closures for "Champagne"-or "Sekt"-type bottles}

Definition statement

This place covers:

Illustrative example of subject matter classified in this group:

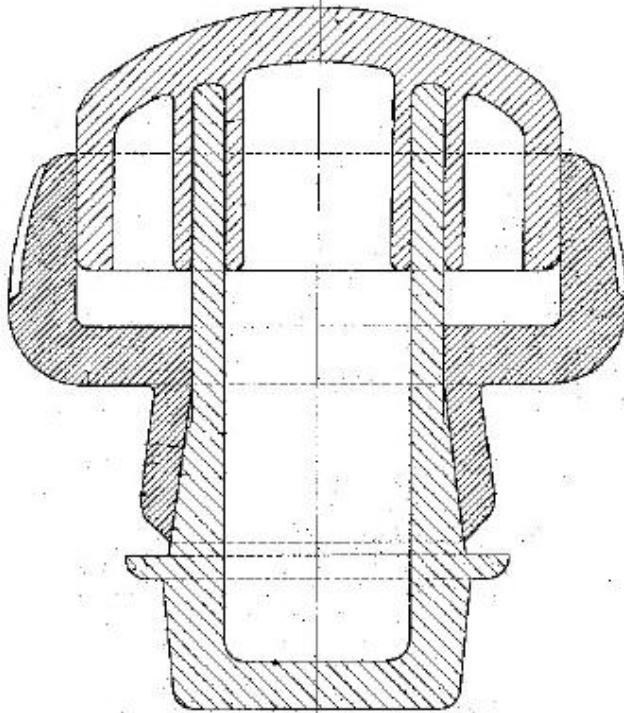

Special rules of classification

The use of available Indexing Codes is mandatory.

B65D 39/007**{Plastic cap-shaped hollow plugs}****Definition statement***This place covers:*

Illustrative example of subject matter classified in this group:

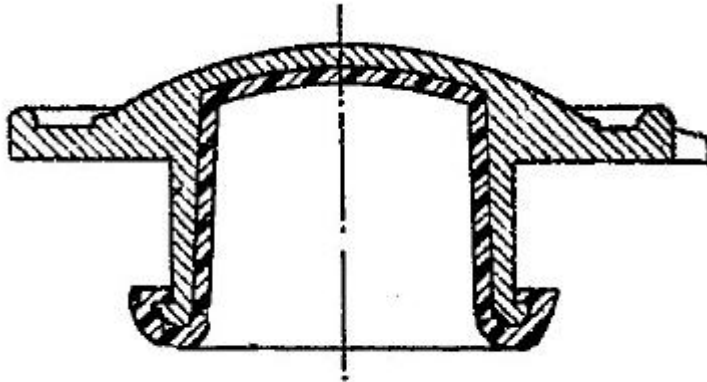
**References*****Limiting references****This place does not cover:*

Cup-shaped hollow plugs	B65D 39/04
-------------------------	----------------------------

Special rules of classification

The use of available Indexing Codes is mandatory.

B65D 39/0076**{Plastic closures other than those covered by groups****[B65D 39/0058](#) - [B65D 39/007](#)}****Special rules of classification**

The use of available Indexing Codes is mandatory.

B65D 39/0082

{Swing or hinged stoppers, e.g. for "Grolsch"-type bottles (toggle mechanisms [B65D 45/06](#) or [B65D 45/16](#))}

Definition statement

This place covers:

Illustrative example of subject matter classified in this group:

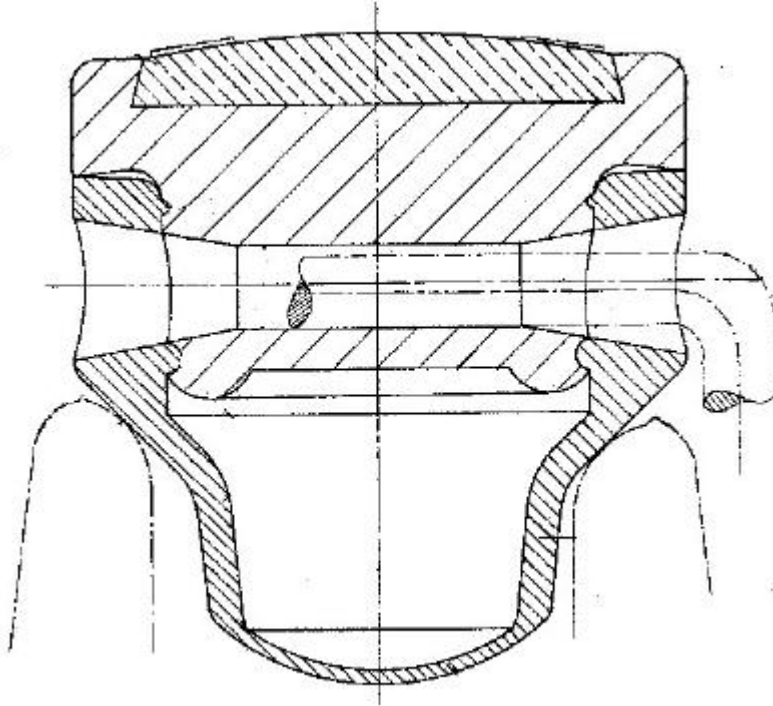

Special rules of classification

The use of available Indexing Codes is mandatory.

B65D 39/0088

{Bungs, e.g. wooden or rubber, for barrels or the like ([B65D 39/08](#) takes precedence)}

Definition statement

This place covers:

Illustrative example of subject matter classified in this group:

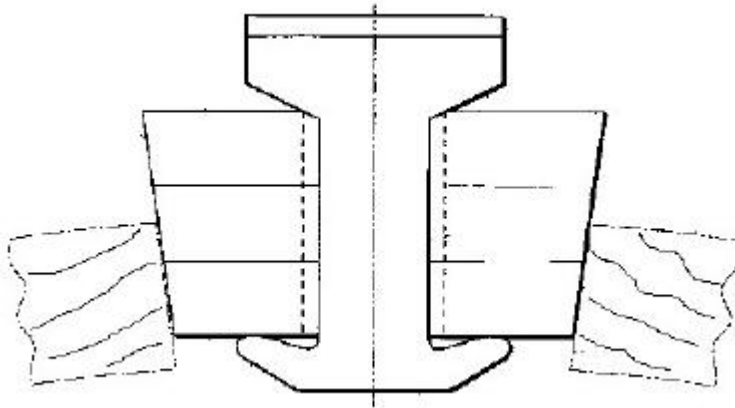
**References****Limiting references**

This place does not cover:

Threaded or like closure members secured by rotation; Bushes therefor	B65D 39/08
---	----------------------------

Special rules of classification

The use of available Indexing Codes is mandatory.

B65D 39/0094

{Glass, ceramic or metal stoppers for perfume bottles or the like ([B65D 39/0082](#) takes precedence)}

Definition statement

This place covers:

Illustrative example of subject matter classified in this group:

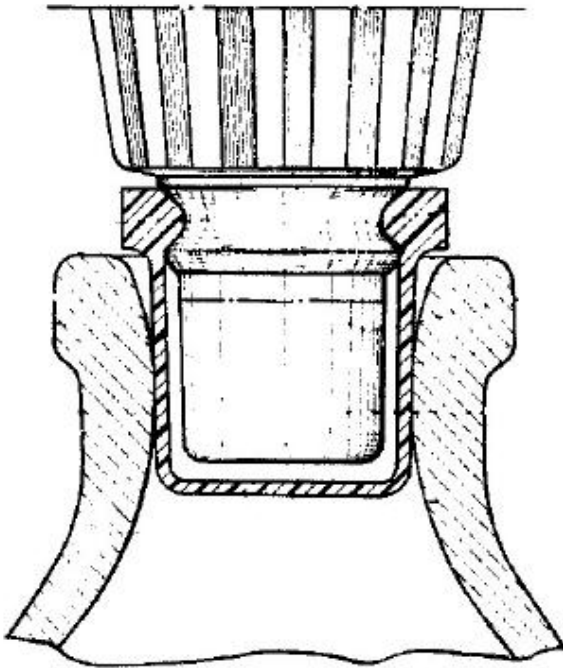

Special rules of classification

The use of available Indexing Codes is mandatory.

B65D 39/02

Disc closures (discs with flanges [B65D 39/04](#))

Definition statement

This place covers:

Illustrative example of subject matter classified in this group:

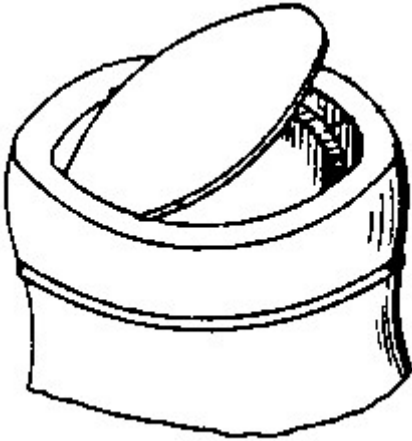

References

Informative references

Attention is drawn to the following places, which may be of interest for search:

Container closures formed after filling the cover being maintained by projections or recesses on the container	B65D 77/2016
Disc closures	B65D 2543/00037

Special rules of classification

The use of available Indexing Codes is mandatory.

B65D 39/025

{the closure being maintained in place by an additional element}

Definition statement

This place covers:

Illustrative example of subject matter classified in this group:

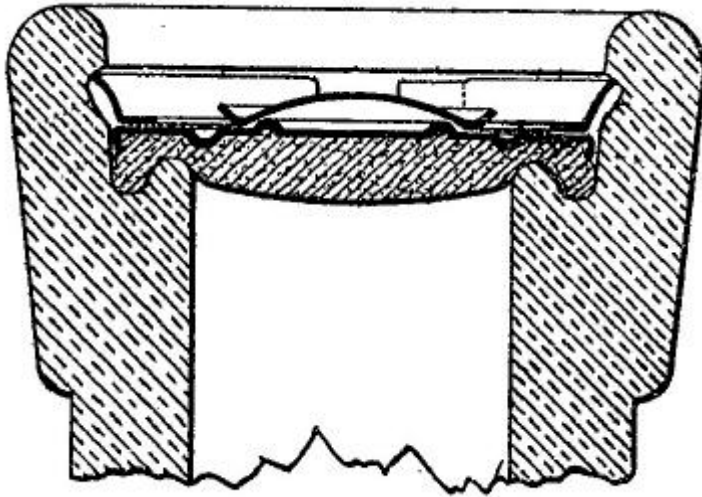

Special rules of classification

The use of available Indexing Codes is mandatory.

B65D 39/04**Cup-shaped plugs or like hollow flanged members****Definition statement**

This place covers:

Illustrative example of subject matter classified in this group:

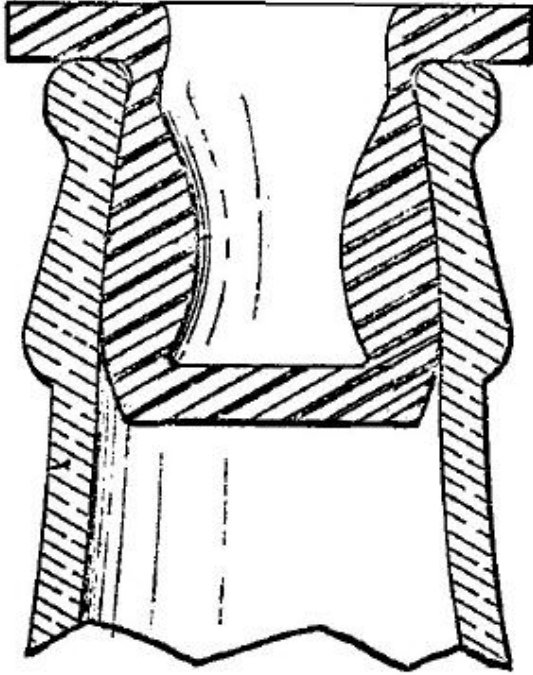
**References****Limiting references**

This place does not cover:

Cap-shaped hollow plugs	B65D 39/0023 , B65D 39/007
-------------------------	---

Special rules of classification

The use of available Indexing Codes is mandatory.

B65D 39/06

Balls

Definition statement

This place covers:

Illustrative example of subject matter classified in this group:

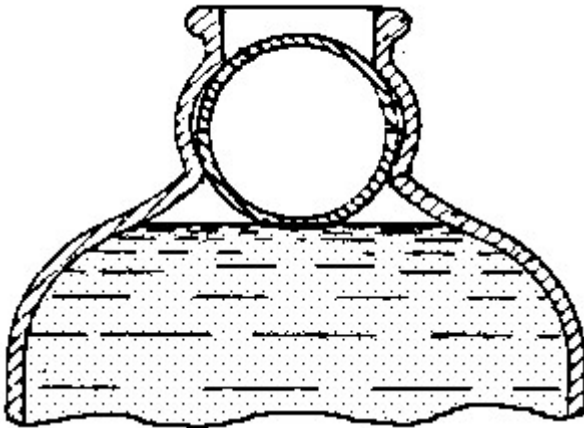

References

Informative references

Attention is drawn to the following places, which may be of interest for search:

Weighted valves	B65D 49/04
-----------------	----------------------------

B65D 39/08

Threaded or like closure members secured by rotation; Bushes therefor

Definition statement

This place covers:

Illustrative example of subject matter classified in this group:

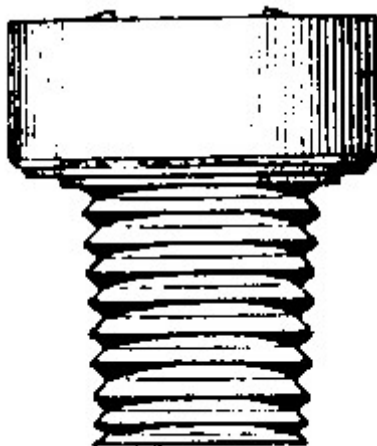

References

Informative references

Attention is drawn to the following places, which may be of interest for search:

Caps or cap-like covers without lines of weakness engaging a bung-ring clamped on the neck or in the wall	B65D 41/083
---	-----------------------------

B65D 39/084

{Separated bung-rings made by one element}

Definition statement

This place covers:

Illustrative example of subject matter classified in this group:



B65D 39/086

{Separated bung-rings made by several elements}

Definition statement

This place covers:

Illustrative example of subject matter classified in this group (US1906205).

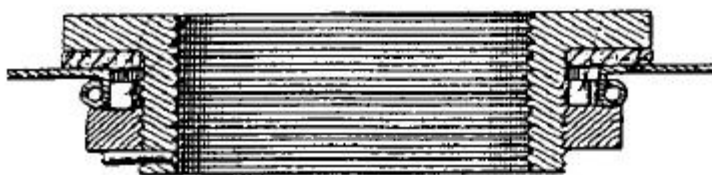

B65D 39/088

{Bungs with special means facilitating handling thereof}

Definition statement

This place covers:

Illustrative example of subject matter classified in this group:

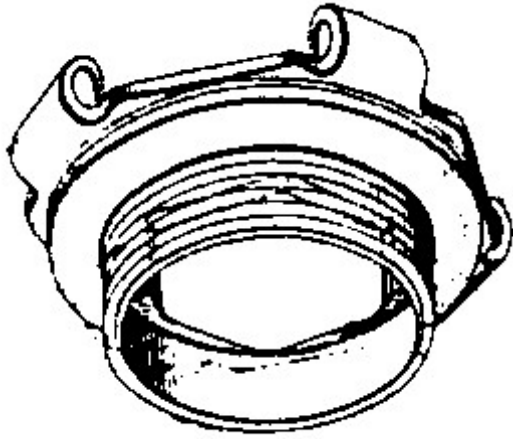

B65D 39/10

with bayonet cams

Definition statement

This place covers:

Illustrative example of subject matter classified in this group:

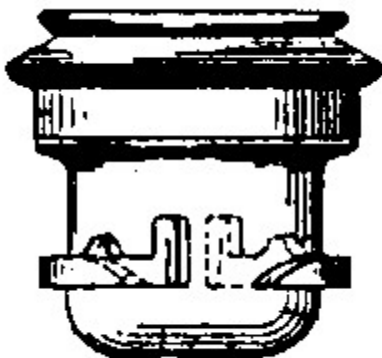

B65D 39/12**expandible, e.g. inflatable****Definition statement***This place covers:*

Illustrative example of subject matter classified in this group:

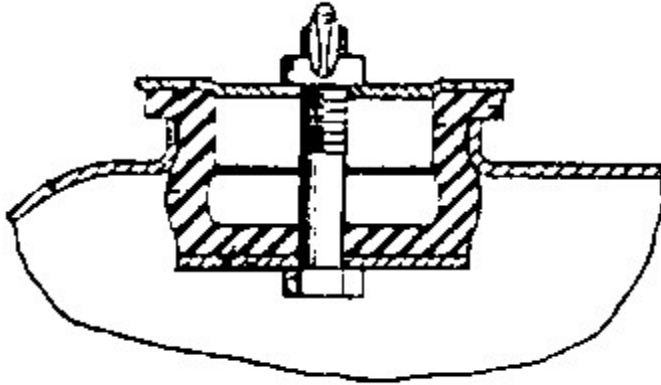
**References*****Informative references****Attention is drawn to the following places, which may be of interest for search:*

Clamping or other pressure-applying devices being an annular member applying radial pressure against the inner surface of the container wall
--

B65D 45/327

B65D 39/14

extending through lateral openings in necks

Definition statement

This place covers:

Illustrative example of subject matter classified in this group:

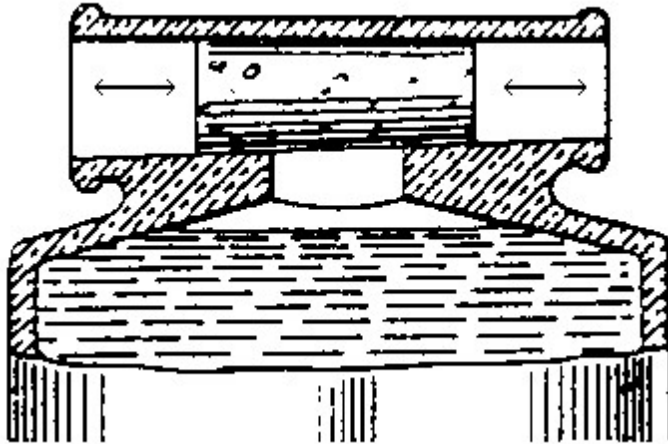

B65D 39/16

with handles or other special means facilitating manual actuation

Definition statement

This place covers:

Illustrative example of subject matter classified in this group (US2249022).

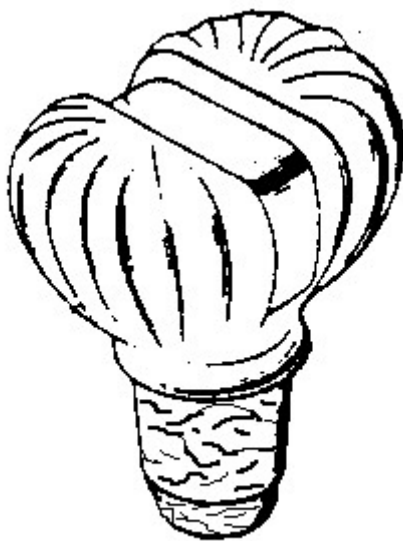

References

Informative references

Attention is drawn to the following places, which may be of interest for search:

Caps combined with stoppers	B65D 41/28
Caps or cap-like covers combined with stoppers	B65D 41/58

Special rules of classification

The use of available Indexing Codes is mandatory.

B65D 41/00

Caps, e.g. crown caps or crown seals, i.e. members having parts arranged for engagement with the external periphery of a neck or wall defining a pouring opening or discharge aperture; Protective cap-like covers for closure members, e.g. decorative covers of metal foil or paper ([B65D 45/00](#) takes precedence)

References

Limiting references

This place does not cover:

Clamping or other pressure-applying devices for securing or retaining closure members	B65D 45/00
Closing bottles or jars by applying closure members	B67B

B65D 41/026

{Caps or cap-like covers attached to the bottle neck by sliding them perpendicularly to the neck axis}

Definition statement

This place covers:

Illustrative example of subject matter classified in this group:

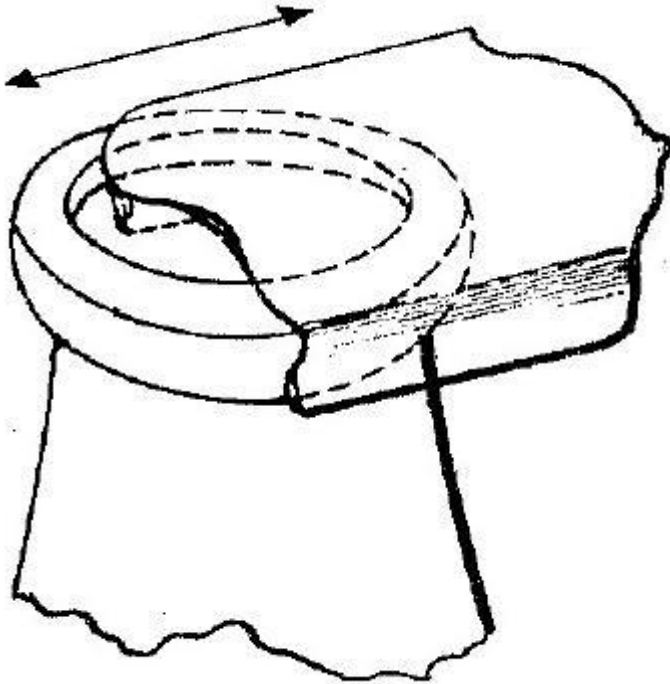
**B65D 41/04**

Threaded or like caps or cap-like covers secured by rotation

References**Limiting references**

This place does not cover:

Push-on and twist-off	B65D 41/17
For venting means	B65D 51/1622 , B65D 51/1661 , B65D 51/1688
Materials in mouldable or extrudable form for sealing or packing joints or covers	C09K 3/10

B65D 41/0414

{formed by a plug, collar, flange, rib or the like contacting the internal surface of a container neck}

Definition statement

This place covers:

Illustrative example of subject matter classified in this group:

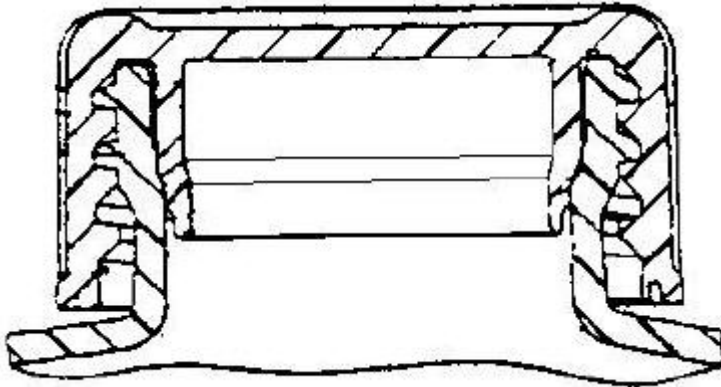

B65D 41/0421

{and combined with integral sealing means contacting other surfaces of a container neck}

Definition statement

This place covers:

Illustrative example of subject matter classified in this group:

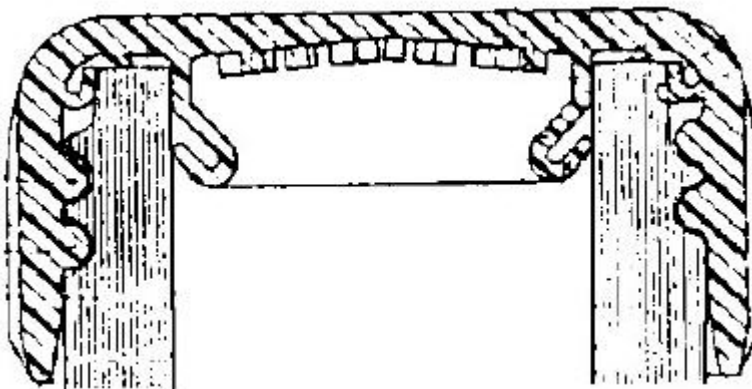

B65D 41/0428

{formed by a collar, flange, rib or the like contacting the top rim or the top edges or the external surface of a container neck ([B65D 41/0421](#) takes precedence)}

Definition statement

This place covers:

Illustrative example of subject matter classified in this group:

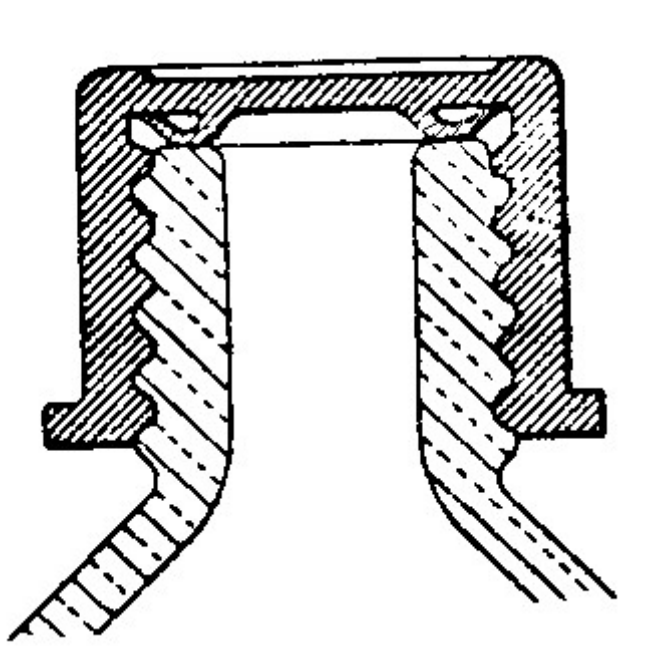
**B65D 41/0435**

{with separate sealing elements}

References**Limiting references**

This place does not cover:

If the threading is of importance, or integral and separate sealing element	B65D 41/04
Combination stopper and cap	B65D 41/28
Disc or annular member held in closed position by threads	B65D 45/30
Disc held in sealing engagement with container mouth	B65D 51/14

B65D 41/0442

{Collars or rings ([B65D 41/0457](#) takes precedence)}

Definition statement

This place covers:

Illustrative example of subject matter classified in this group:

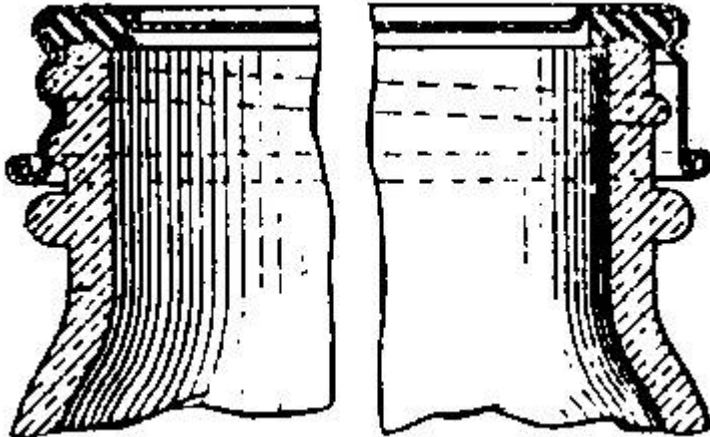
**References****Limiting references**

This place does not cover:

The sealing element covering or co-operating with the screw-thread or the like of a container neck	B65D 41/0457
--	------------------------------

B65D 41/045**{Discs ([B65D 41/0457](#) takes precedence)}****Definition statement***This place covers:*

Illustrative example of subject matter classified in this group:

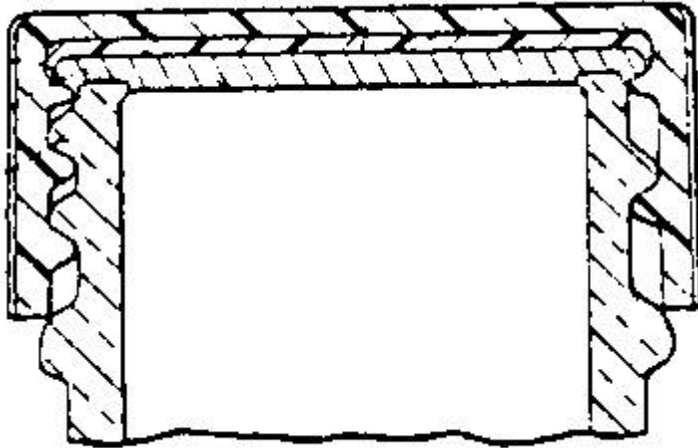
**References*****Limiting references****This place does not cover:*

The sealing element covering or co-operating with the screw-thread or the like of a container neck	B65D 41/0457
--	------------------------------

Informative references*Attention is drawn to the following places, which may be of interest for search:*

Discs	B65D 53/04
-------	----------------------------

B65D 41/0457

{the sealing element covering or co-operating with the screw-thread or the like of a container neck}

Definition statement

This place covers:

Illustrative example of subject matter classified in this group:

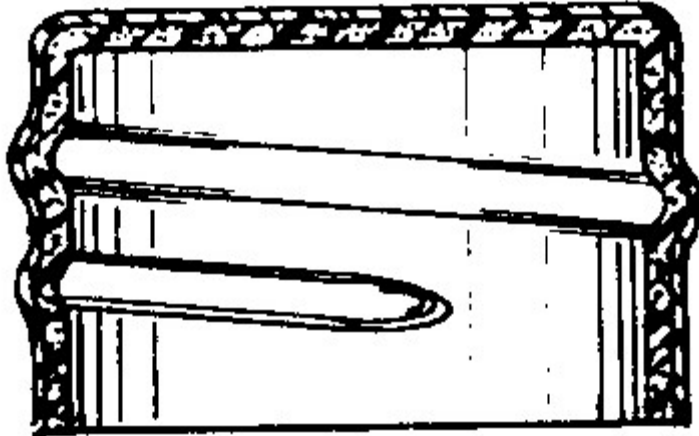

B65D 41/0464

{the screw-thread or the like being formed by conforming the cap-skirt to the thread or the like formation on a container neck}

Definition statement

This place covers:

Illustrative example of subject matter classified in this group:

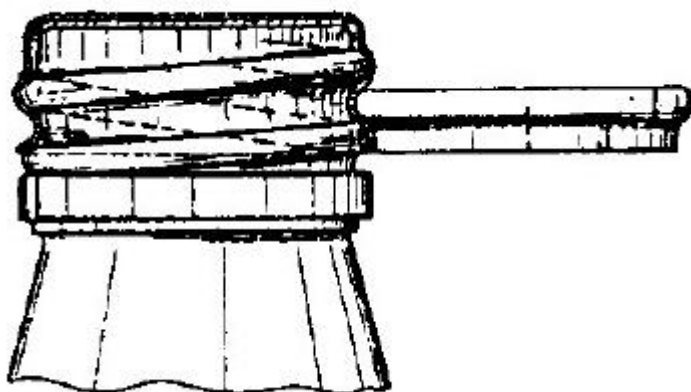

B65D 41/0471

{with means for positioning the cap on the container, or for limiting the movement of the cap, or for preventing accidental loosening of the cap}

Definition statement

This place covers:

Illustrative example of subject matter classified in this group:

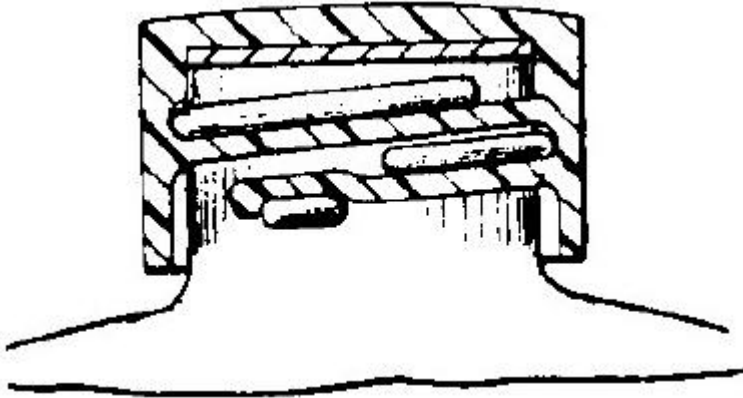
**References****Limiting references**

This place does not cover:

Double wall caps	B65D 41/0492
Closures in general	B65D 2251/04

B65D 41/0485

{with means specially adapted for facilitating the operation of opening or closing}

Definition statement

This place covers:

Illustrative example of subject matter classified in this group:

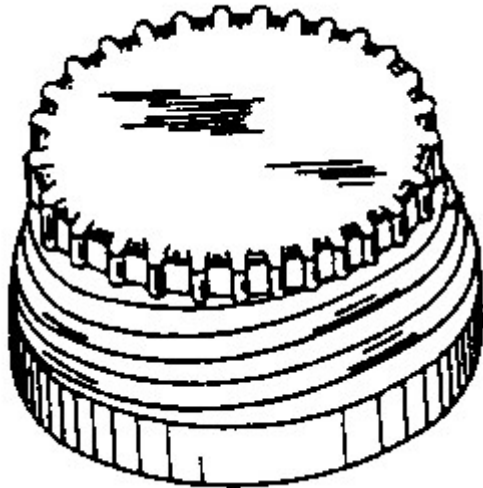

B65D 41/0492

{formed by several elements connected together ([B65D 41/0478](#) takes precedence)}

Definition statement

This place covers:

Illustrative example of subject matter classified in this group:

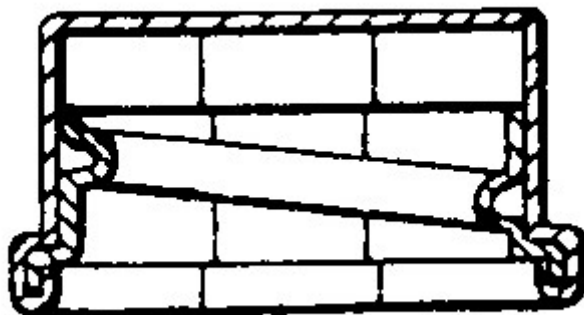

B65D 41/06

with bayonet cams {, i.e. removed by first pushing axially to disengage the cams and then rotating}

Definition statement

This place covers:

Illustrative example of subject matter classified in this group:

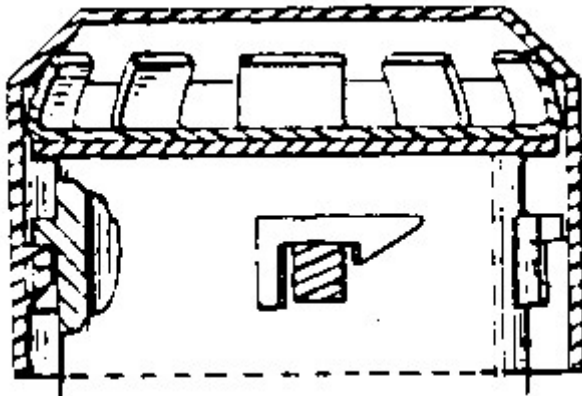
**B65D 41/065**

{with integral internal sealing means}

Definition statement

This place covers:

Illustrative example of subject matter classified in this group:

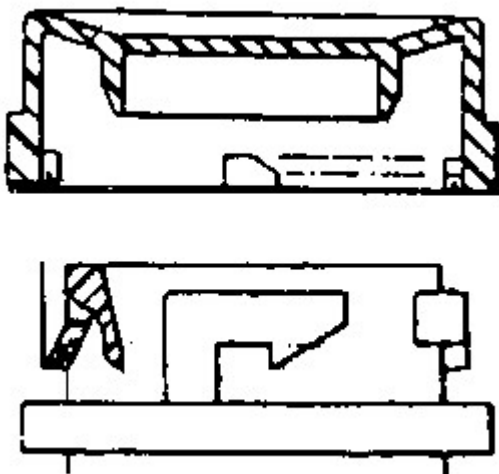

B65D 41/08

engaging a threaded ring clamped on the external periphery of the neck or wall

Definition statement

This place covers:

Illustrative example of subject matter classified in this group:

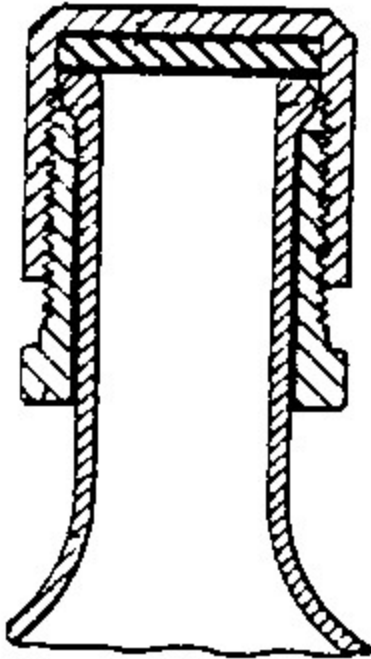

References

Informative references

Attention is drawn to the following places, which may be of interest for search:

Screw-threaded or bayonet-type annular members cooperating with an intermediate ring
--

B65D 45/305

B65D 41/083

{engaging a bung-ring clamped on the neck or in the wall}

Definition statement

This place covers:

Illustrative example of subject matter classified in this group:

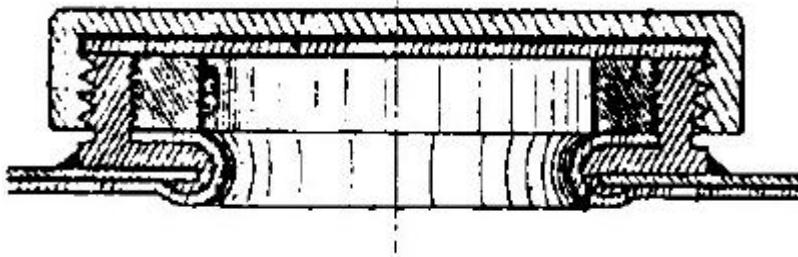
**References****Informative references**

Attention is drawn to the following places, which may be of interest for search:

Threaded or like closure members secured by rotation; Bushes therefor	B65D 39/08
---	----------------------------

B65D 41/086

{with integral internal sealing means}

Definition statement

This place covers:

Illustrative example of subject matter classified in this group:

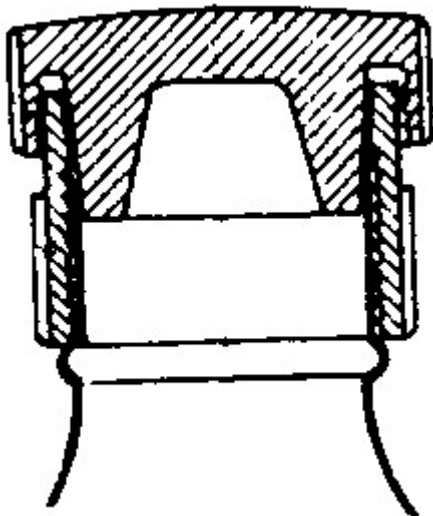

B65D 41/10

Caps or cap-like covers adapted to be secured in position by permanent deformation of the wall-engaging parts

Definition statement

This place covers:

Illustrative example of subject matter classified in this group:

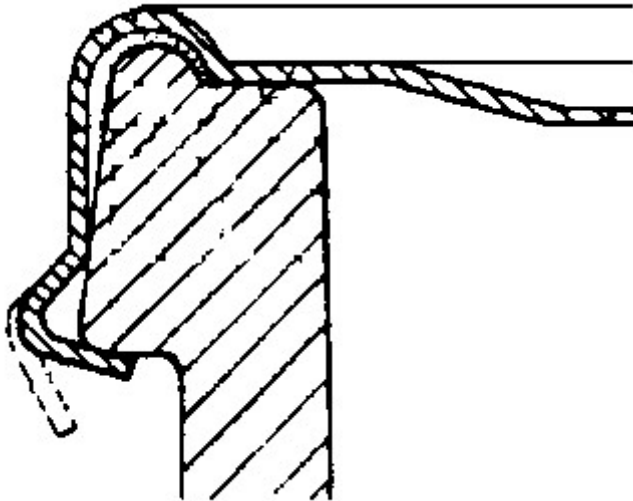

B65D 41/12

made of relatively stiff metallic materials, e.g. crown caps

Definition statement

This place covers:

Illustrative example of subject matter classified in this group:

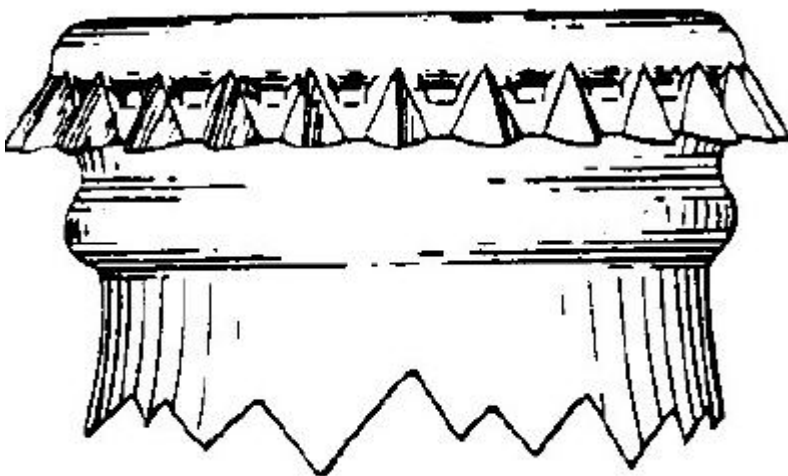

B65D 41/14

made of metallic foil or like thin flexible material

Definition statement

This place covers:

Illustrative example of subject matter classified in this group:

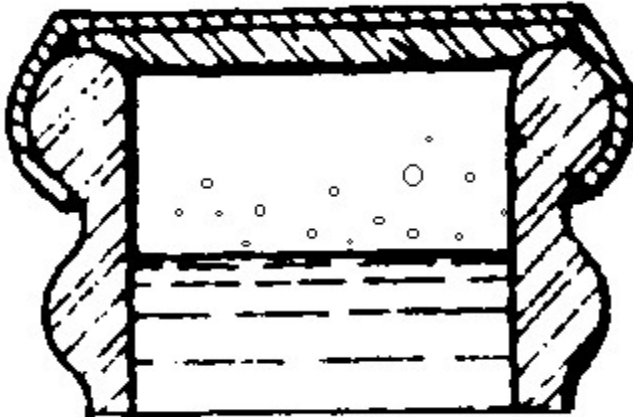

B65D 41/16

Snap-on caps or cap-like covers

Definition statement

This place covers:

Illustrative example of subject matter classified in this group:

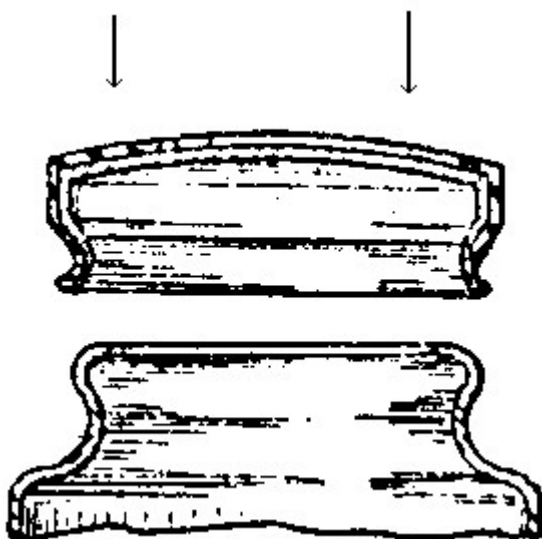

B65D 41/17

push-on and twist-off

Definition statement

This place covers:

Illustrative example of subject matter classified in this group:

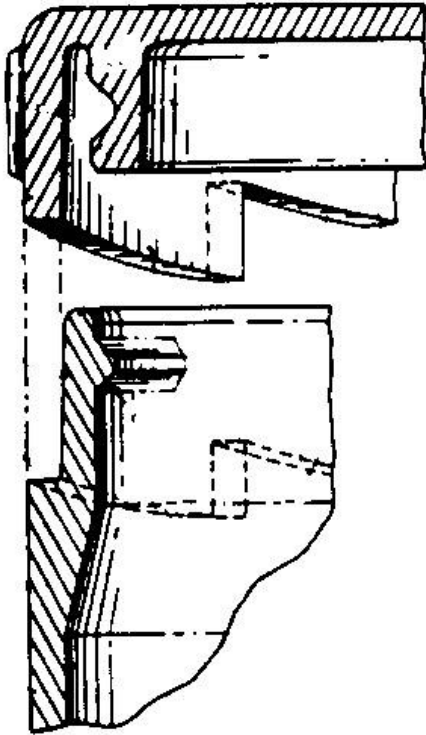

B65D 41/18

non-metallic, e.g. made of paper or plastics {(B65D 41/17 takes precedence)}

Definition statement

This place covers:

Illustrative example of subject matter classified in this group:

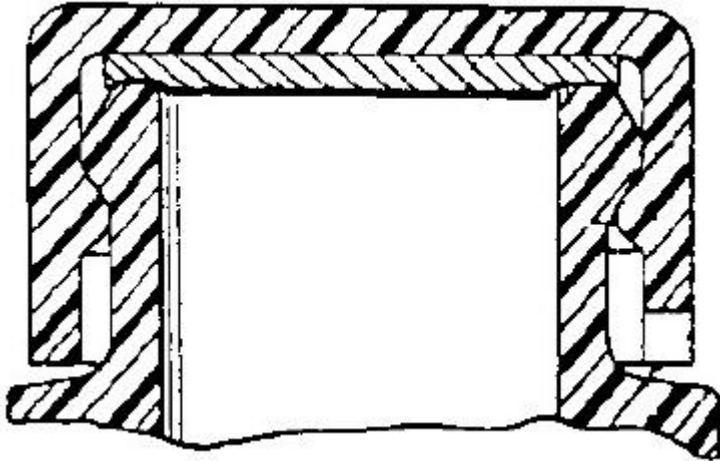

B65D 41/185

{with integral internal sealing means}

Definition statement

This place covers:

Illustrative example of subject matter classified in this group:

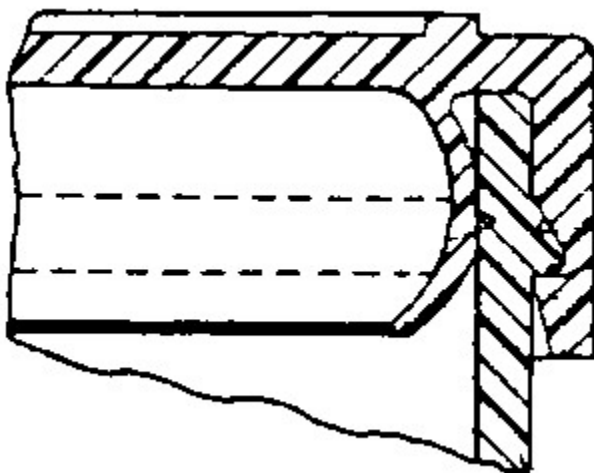

B65D 41/20

Caps or cap-like covers with membranes, e.g. arranged to be pierced

Definition statement

This place covers:

Illustrative example of subject matter classified in this group:

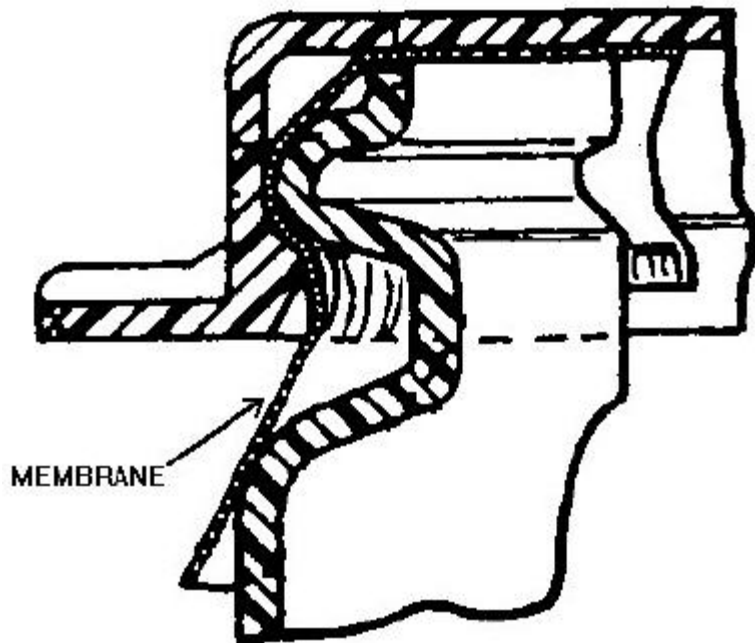
**B65D 41/22**

Caps or cap-like covers with elastic parts adapted to be stretched over the container

Definition statement

This place covers:

Illustrative example of subject matter classified in this group:

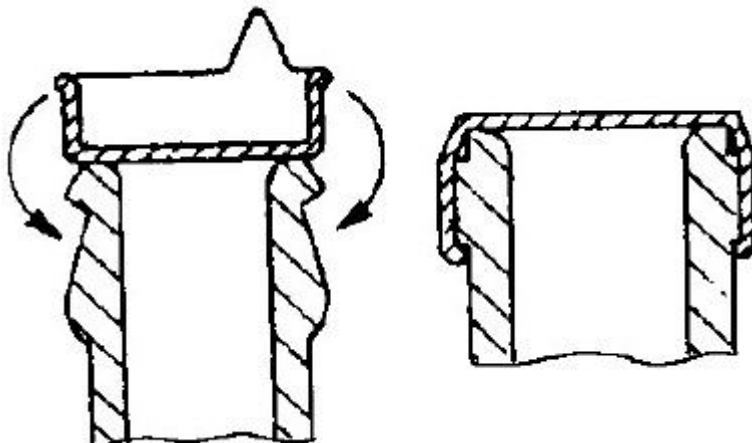

B65D 41/225

{with integral internal sealing means}

Definition statement

This place covers:

Illustrative example of subject matter classified in this group:

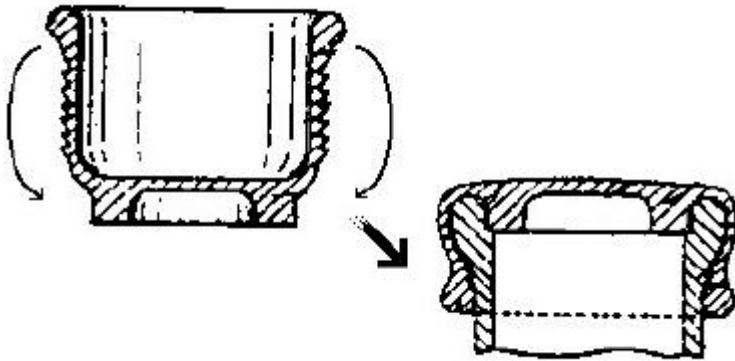

B65D 41/24

Caps or cap-like covers made of shrinkable material or formed in situ by dipping, e.g. using gelatine or celluloid

Definition statement

This place covers:

Illustrative example of subject matter classified in this group:

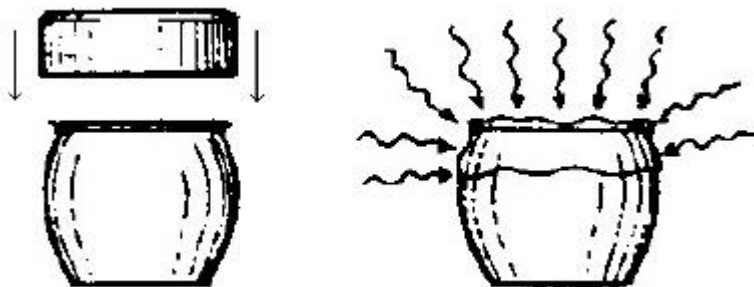

B65D 41/26

Caps or cap-like covers serving as, or incorporating, drinking or measuring vessels

Definition statement

This place covers:

Illustrative example of subject matter classified in this group:

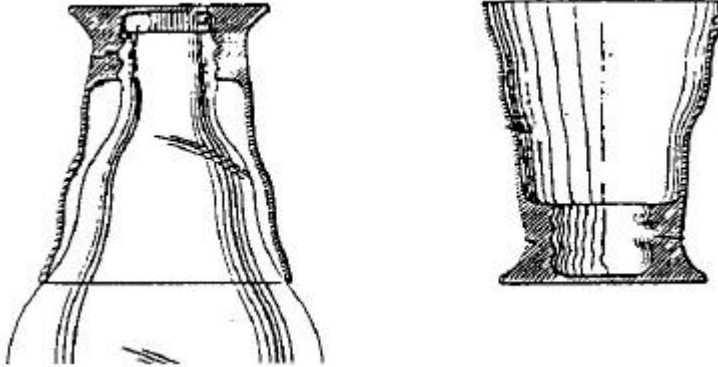

References

Limiting references

This place does not cover:

Box-like containers	B65D 2543/0055
Measuring-cups	G01F 19/00

B65D 41/28**Caps combined with stoppers****Definition statement**

This place covers:

Illustrative example of subject matter classified in this group:

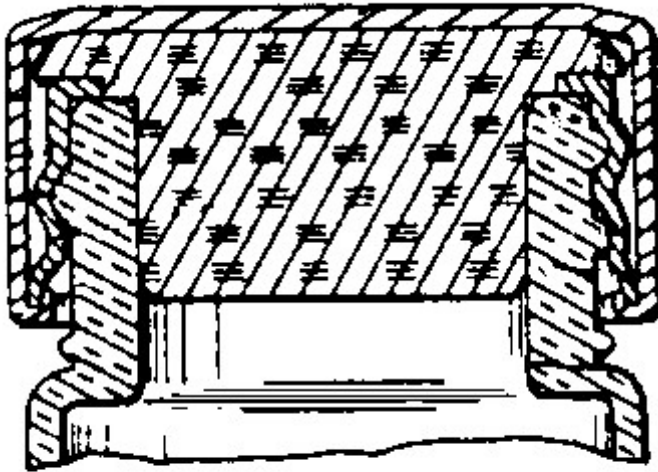
**References****Limiting references**

This place does not cover:

Test tube stoppers	B01L3/50285
--------------------	--------------------

Informative references

Attention is drawn to the following places, which may be of interest for search:

Threaded or like closure members secured by rotation with handles or other special means facilitating manual actuation	B65D 39/16
Arrangements of closures with protective outer cap-like covers or of two or more co-operating closures	B65D 51/18

B65D 41/30

Deformable caps combined with resilient stoppers to permit re-use as temporary closures

Definition statement

This place covers:

Illustrative example of subject matter classified in this group:

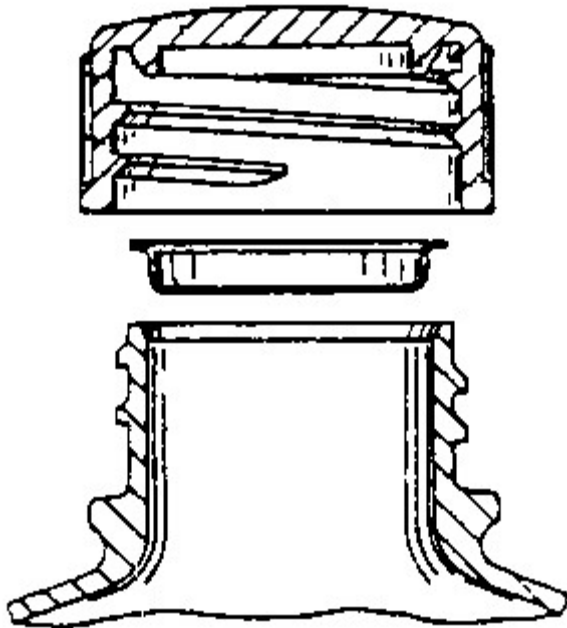
**B65D 41/325**

{with integral internal sealing means}

Definition statement

This place covers:

Sealing means contacting the internal surface of a container neck.

B65D 41/34

Threaded or like caps or cap-like covers {provided with tamper elements formed in, or attached to, the closure skirt}

Definition statement

This place covers:

Known or obvious details about sealing elements.

References

Limiting references

This place does not cover:

Sealing elements	B65D 41/0407 , B65D 41/0435
------------------	--

B65D 41/3409

{the tamper element being integrally connected to the closure by means of bridges}

Definition statement

This place covers:

Illustrative examples of subject matter classified in this group.

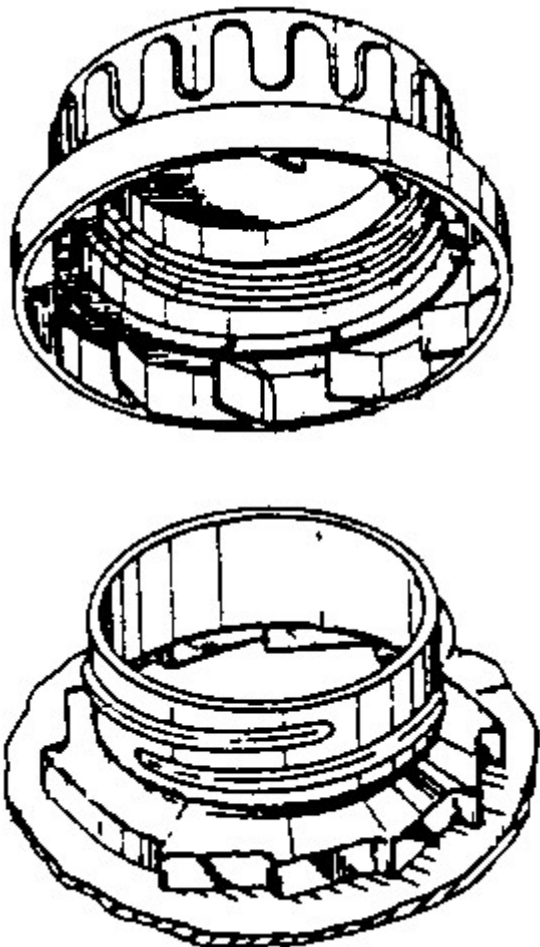

B65D 41/3414

{with drive means between closure and tamper element}

Definition statement

This place covers:

Illustrative example of subject matter classified in this group:



B65D 41/3419

{the tamper element being formed separately but connected to the closure}

Definition statement

This place covers:

Illustrative example of subject matter classified in this group:

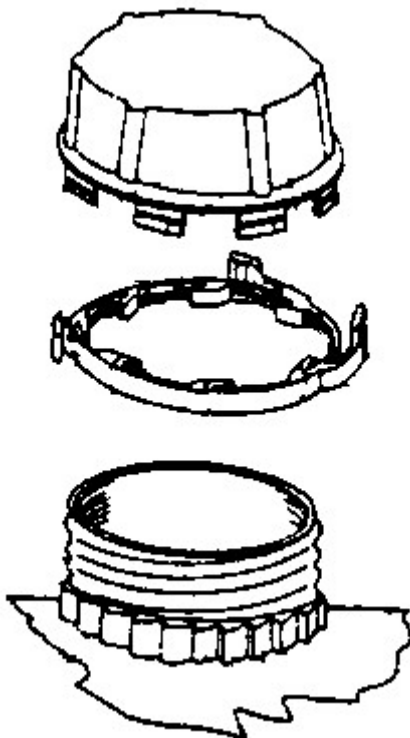

B65D 41/3423

{with flexible tabs, or elements rotated from a non-engaging to an engaging position, formed on the tamper element or in the closure skirt ([B65D 41/3404](#) takes precedence)}

Definition statement

This place covers:

Illustrative example of subject matter classified in this group:

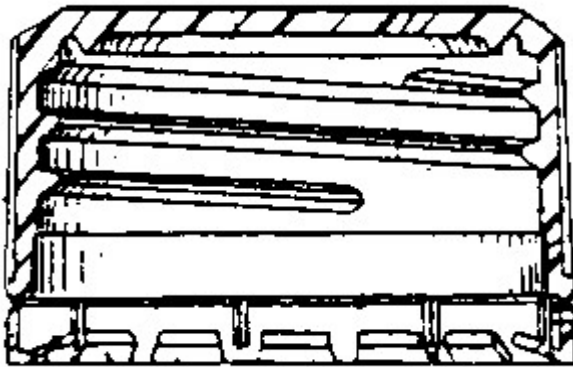

B65D 41/3428

{the tamper element being integrally connected to the closure by means of bridges}

Definition statement

This place covers:

Illustrative example of subject matter classified in this group:

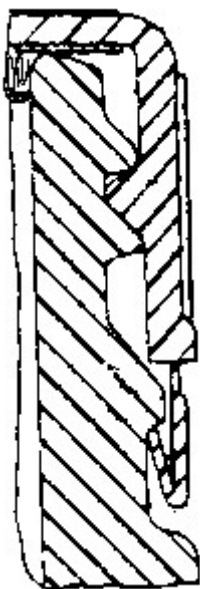

B65D 41/3438

{the tamper element being formed separately but connected to the closure}

Definition statement

This place covers:

Illustrative example of subject matter classified in this group:

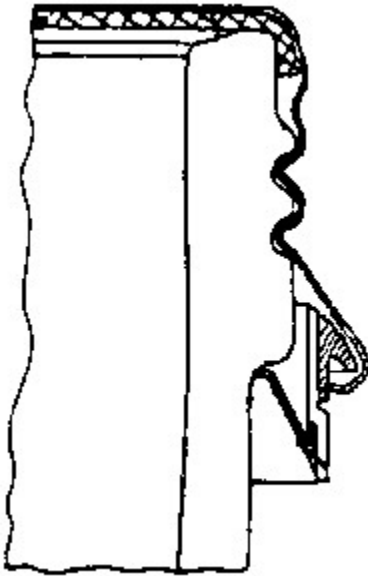

B65D 41/3442

{with rigid bead or projections formed on the tamper element and coating with bead or projections on the container ([B65D 41/3404](#) takes precedence)}

Definition statement

This place covers:

Illustrative example of subject matter classified in this group:

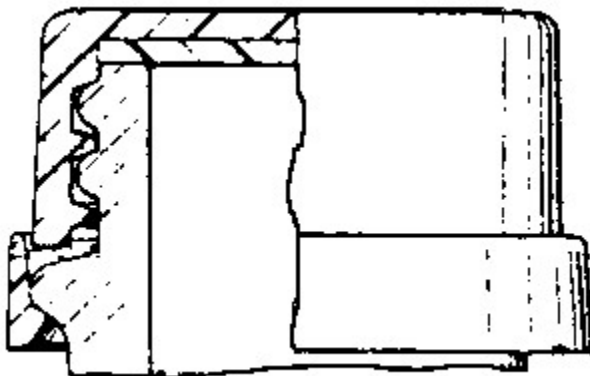

B65D 41/3457

{the tamper element being formed separately but connected to the closure}

Definition statement

This place covers:

Illustrative example of subject matter classified in this group:

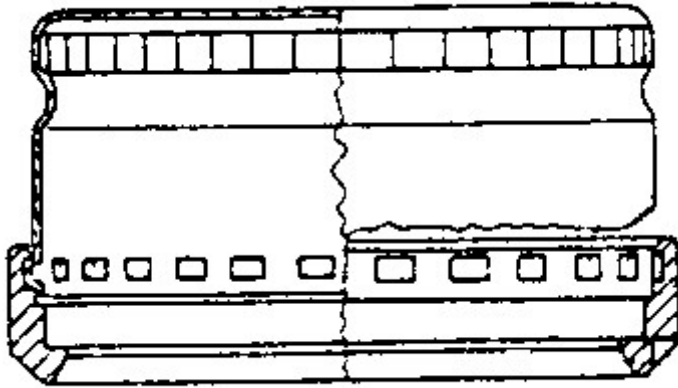

B65D 41/3461

{the tamper element being retracted by heat or by heat and pressure}

Definition statement

This place covers:

Illustrative example of subject matter classified in this group:

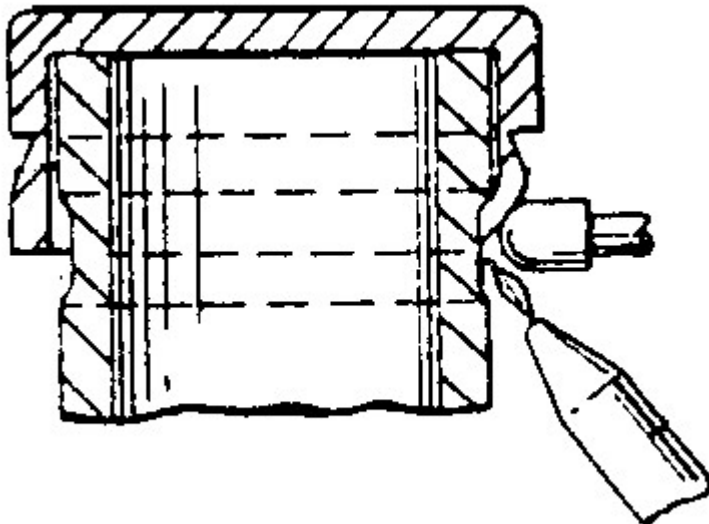

B65D 41/3466

{and being integrally connected to the closure by means of bridges}

Definition statement

This place covers:

Illustrative example of subject matter classified in this group:

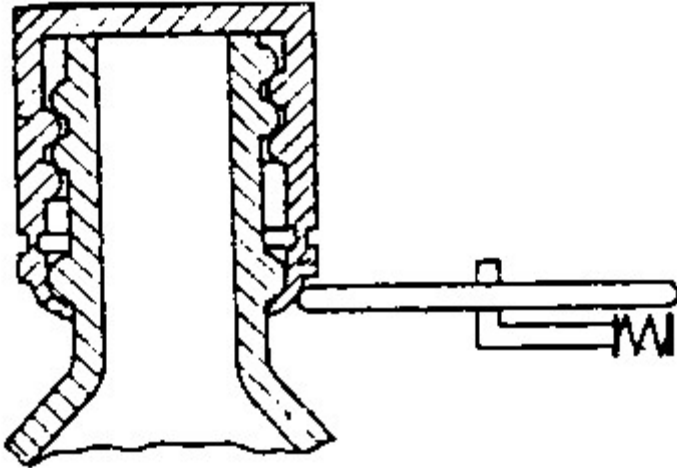

B65D 41/3476

{and being formed separately but connected to the closure}

Definition statement

This place covers:

Illustrative example of subject matter classified in this group:

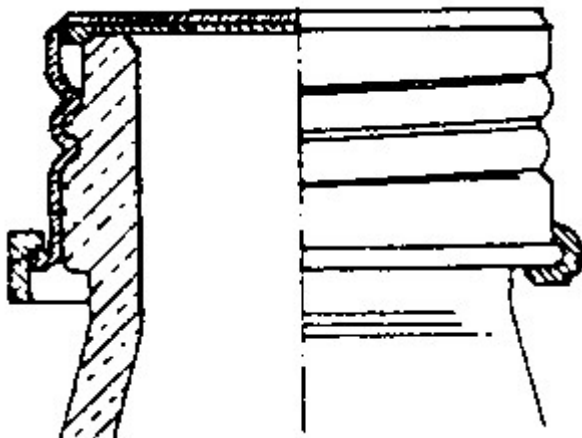

B65D 41/348

{the tamper element being rolled or pressed to conform to the shape of the container, e.g. metallic closures ([B65D 41/3404](#), [B65D 41/3423](#) take precedence)}

Definition statement

This place covers:

Illustrative example of subject matter classified in this group:

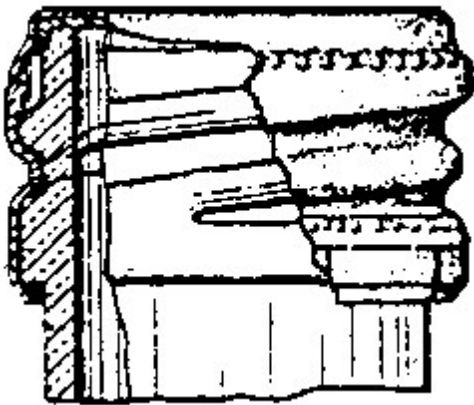

B65D 41/3485

{having tear-off strips}

Definition statement

This place covers:

Illustrative example of subject matter classified in this group (US3363793).

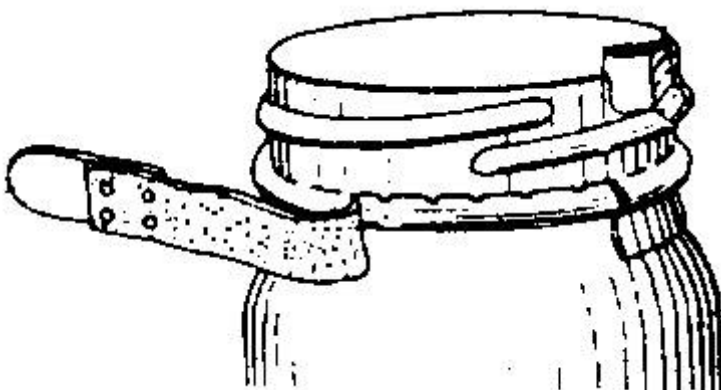

B65D 41/349

{the tamper element being formed separately but connected to the closure}

Definition statement

This place covers:

Illustrative example of subject matter classified in this group:

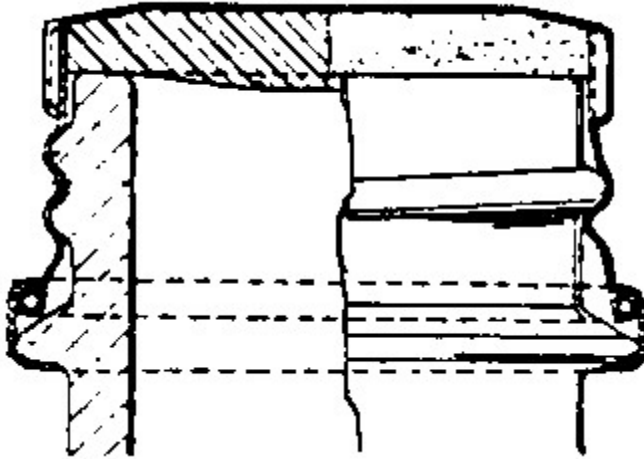

B65D 41/3495

{the tamper element being bonded or adhered to the container wall
([B65D 41/3461](#) takes precedence)}

Definition statement

This place covers:

Illustrative example of subject matter classified in this group:

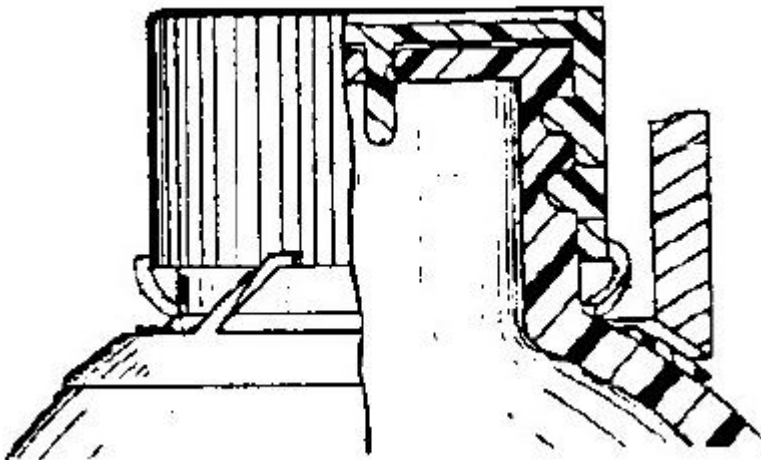

B65D 41/36

with bayonet cams {, i.e. removed by first pushing axially to disengage the cams and then rotating}

Definition statement

This place covers:

Illustrative example of subject matter classified in this group:

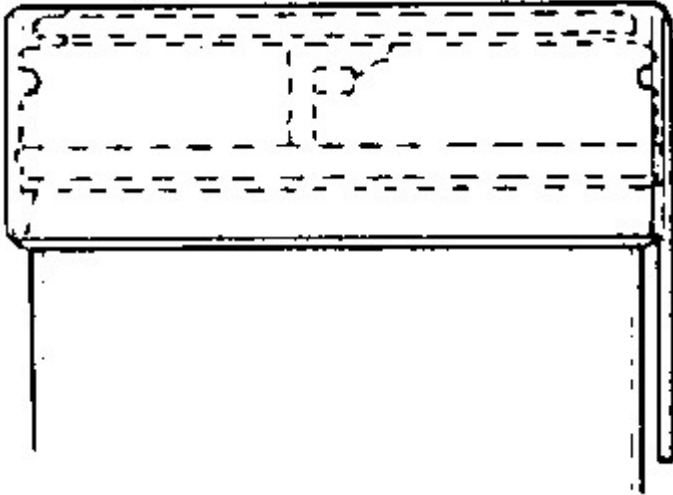

B65D 41/38

engaging a threaded ring clamped on the external periphery of the neck or wall

Definition statement

This place covers:

Illustrative example of subject matter classified in this group:

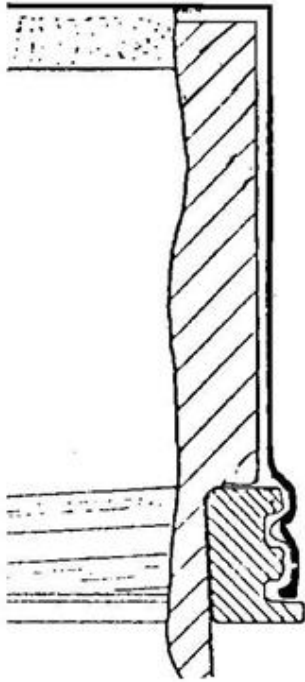

B65D 41/42

made of relatively-stiff metallic material, e.g. crown caps

Definition statement

This place covers:

Illustrative example of subject matter classified in this group:

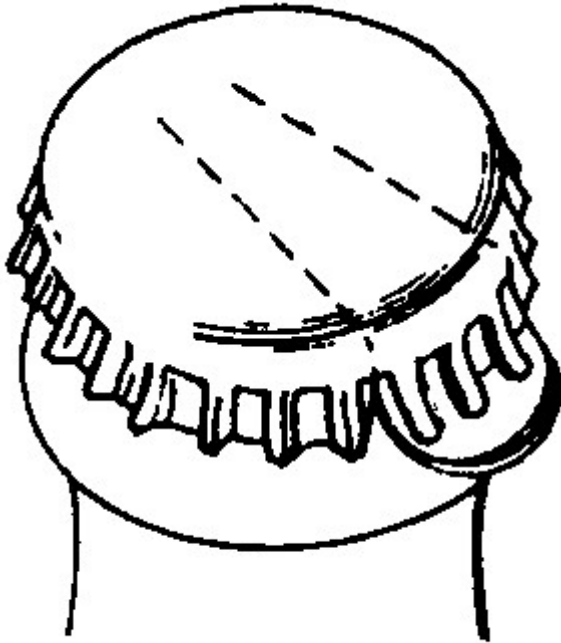

B65D 41/44

made of metallic foil or like thin flexible material

Definition statement

This place covers:

Illustrative example of subject matter classified in this group:

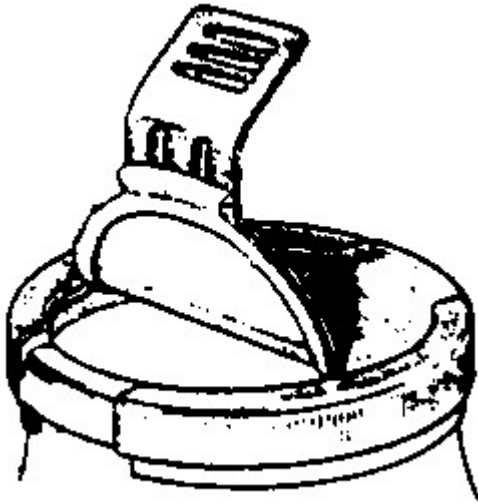

B65D 41/46

Snap-on caps or cap-like covers

Definition statement

This place covers:

Illustrative example of subject matter classified in this group:

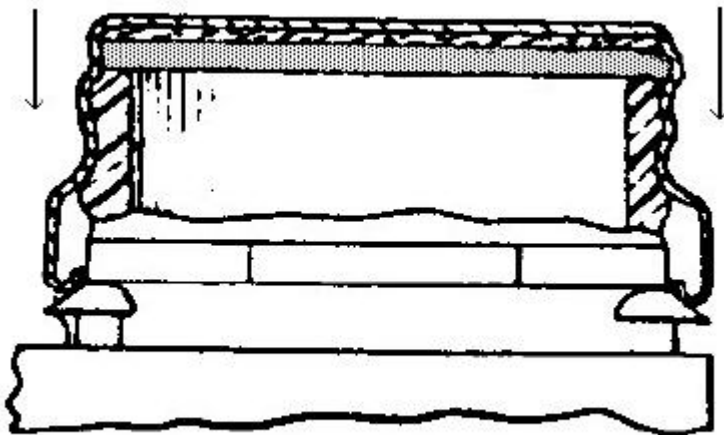

B65D 41/47**push-on and twist-off****Definition statement***This place covers:*

Illustrative example of subject matter classified in this group:

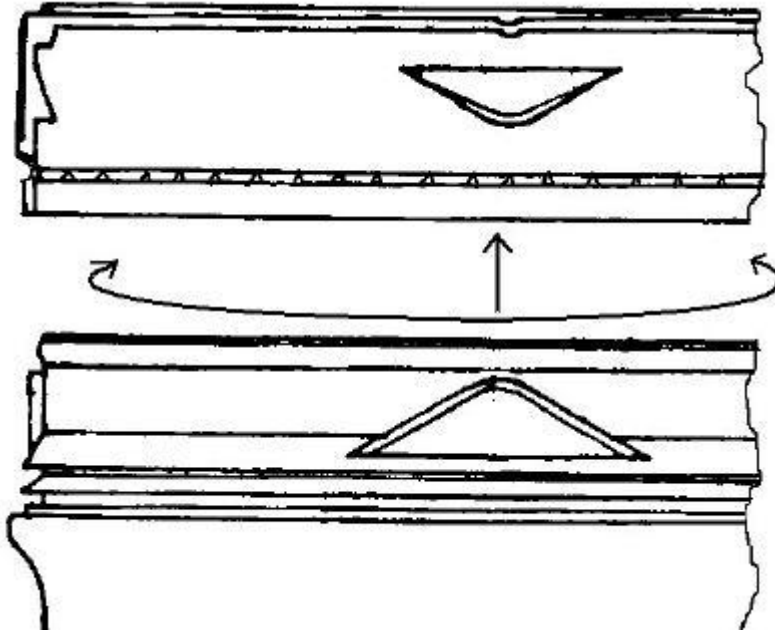
**B65D 41/48****non-metallic, e.g. made of paper or plastics {(B65D 41/47 takes precedence)}****Definition statement***This place covers:*

Illustrative example of subject matter classified in this group:

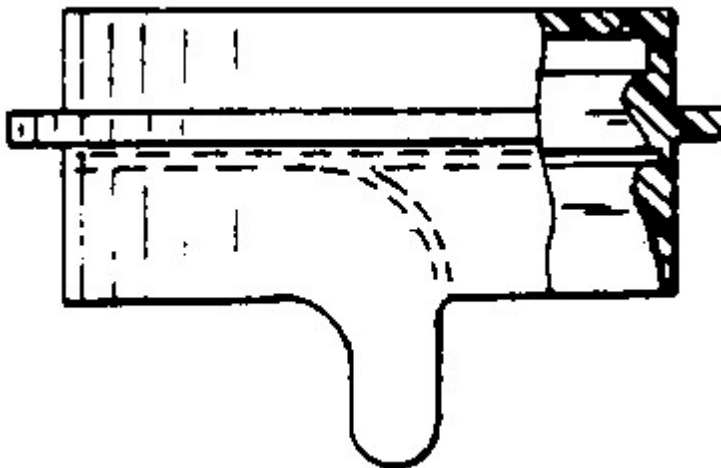

B65D 41/485**{with integral internal sealing means}****Definition statement***This place covers:*

Illustrative example of subject matter classified in this group:

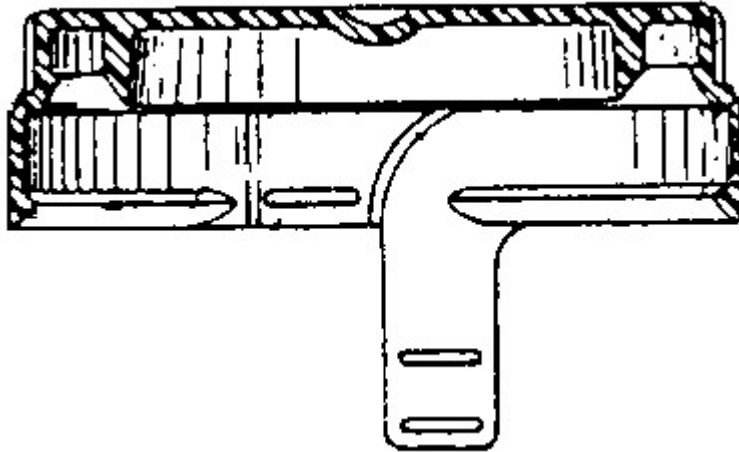
**B65D 41/50****Caps or cap-like covers with membranes, e.g. arranged to be pierced****Definition statement***This place covers:*

Illustrative example of subject matter classified in this group:

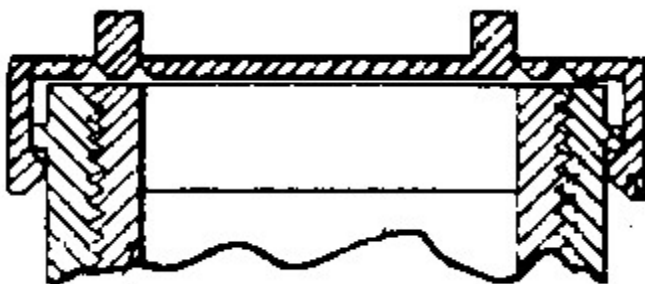
**References****Informative references***Attention is drawn to the following places, which may be of interest for search:*

The bottle or container being held upside down and provided with a closure	B67D 3/0032
--	-----------------------------

B65D 41/52

Caps or cap-like covers with elastic parts adapted to be stretched over the container

Definition statement

This place covers:

Illustrative example of subject matter classified in this group:

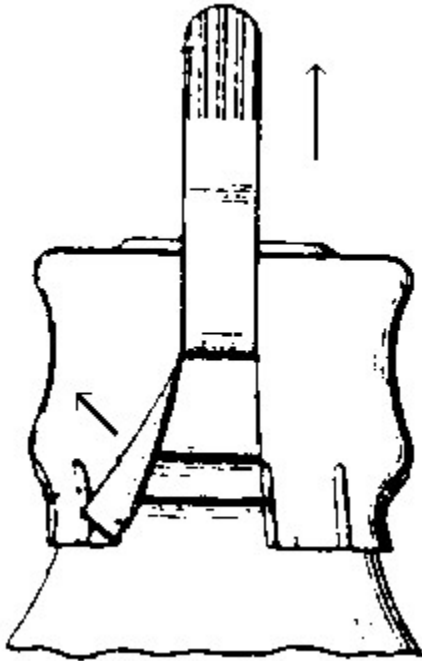

B65D 41/54

Caps or cap-like covers made of shrinkable material or formed in situ by dipping, e.g. using gelatine or celluloid

Definition statement

This place covers:

Illustrative example of subject matter classified in this group:

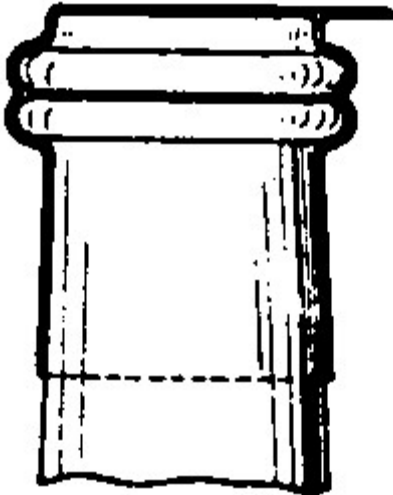
**References****Limiting references**

This place does not cover:

Shrink-film bands	B65D 55/0854
-------------------	------------------------------

B65D 41/56

Caps or cap-like covers serving as, or incorporating, drinking or measuring vessels

References**Limiting references**

This place does not cover:

Box-like containers	B65D 2543/00055
Measuring-cups	G01F 19/00

B65D 41/565

{with integral internal sealing means}

Definition statement

This place covers:

Illustrative example of subject matter classified in this group:

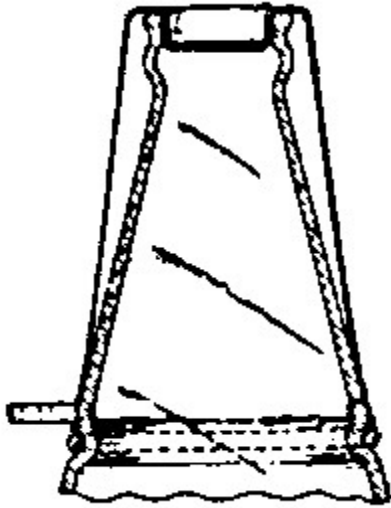

B65D 41/58

Caps or cap-like covers combined with stoppers

Definition statement

This place covers:

Illustrative example of subject matter classified in this group:

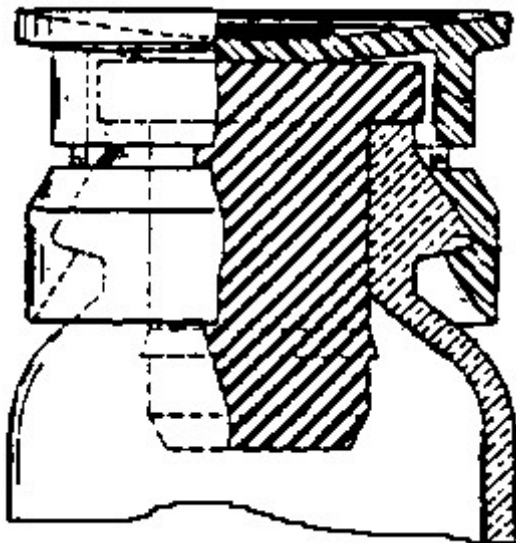

References

Limiting references

This place does not cover:

Arrangements of closures with protective outer cap-like covers or of two or more co-operating closures	B65D 51/18
--	----------------------------

Informative references

Attention is drawn to the following places, which may be of interest for search:

Closures arranged within necks or pouring openings or in discharge apertures with handles or other special means facilitating manual actuation	B65D 39/16
--	----------------------------

B65D 41/60

Deformable caps combined with resilient stoppers to permit re-use as temporary closures

Definition statement

This place covers:

Illustrative example of subject matter classified in this group:

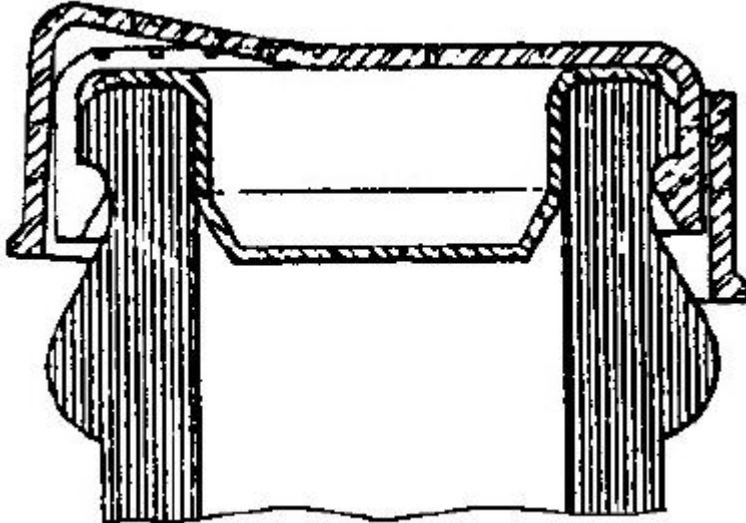

B65D 41/62**Secondary protective cap-like outer covers for closure members****Definition statement***This place covers:*

Illustrative example of subject matter classified in this group:

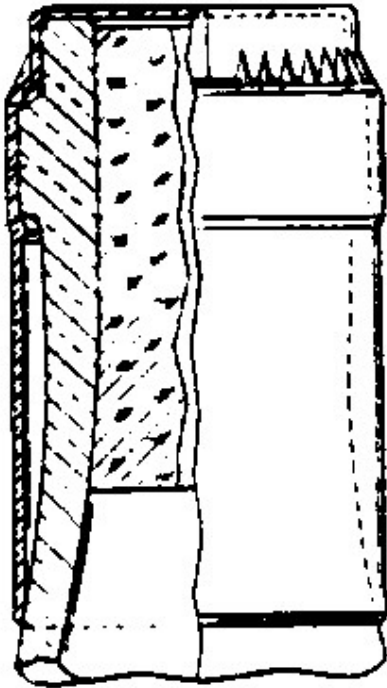
**B65D 43/02****Removable lids or covers (with means for piercing, cutting, or tearing a frangible inner closure [B65D 51/22](#))****References****Limiting references***This place does not cover:*

Flexible covers with elastic parts adapted to be stretched over the container	B65D 41/22 , B65D 41/52
Flexible lids or covers welded or glued to the container body	B65D 77/20
Covers or lids for paint cans	B44D 3/127
Removable closures for access or drainage openings	B62D 25/24

B65D 43/0204

{secured by snapping over beads or projections}

Definition statement

This place covers:

Illustrative example of subject matter classified in this group:

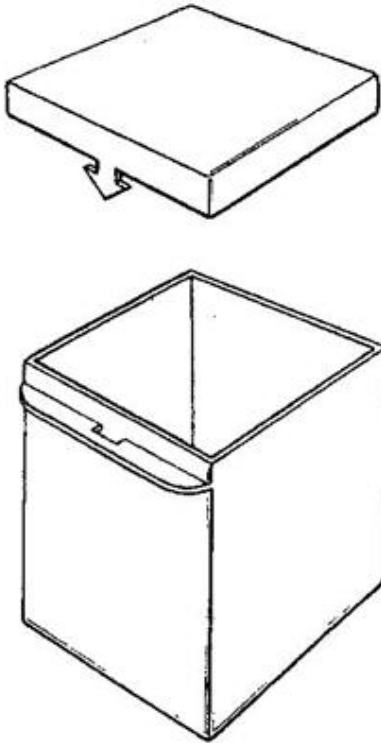

Special rules of classification

The use of available Indexing Codes is mandatory.

B65D 43/0206

{inside a peripheral U-shaped channel in the mouth of the container}

Definition statement

This place covers:

Illustrative example of subject matter classified in this group:

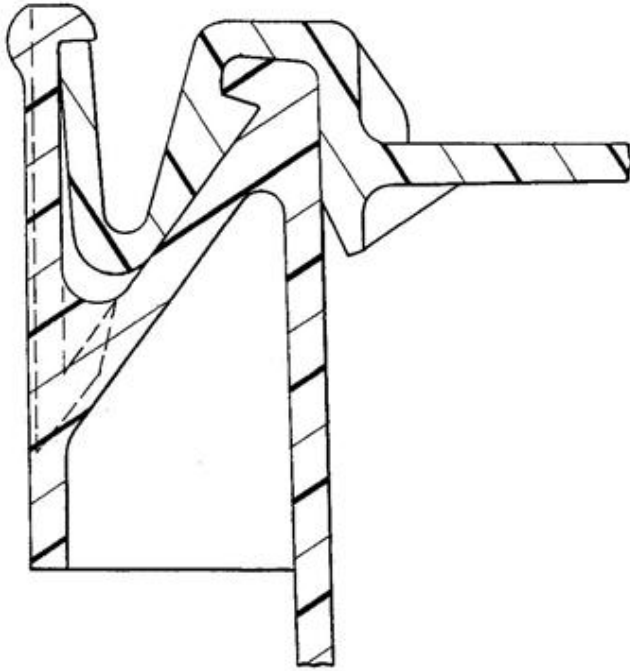

Special rules of classification

The use of available Indexing Codes is mandatory.

B65D 43/0208

{on both the inside and the outside of the mouth of the container
([B65D 43/0206](#) takes precedence)}

Definition statement

This place covers:

Illustrative example of subject matter classified in this group:

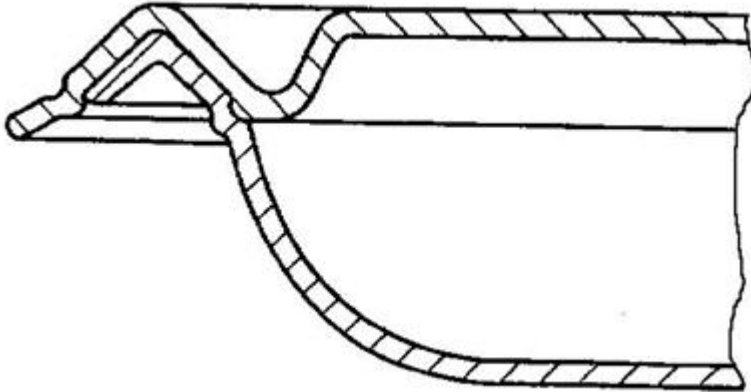
**Special rules of classification**

The use of available Indexing Codes is mandatory.

B65D 43/021

{only on the inside, or a part turned to the inside, of the mouth ([B65D 43/0206](#) takes precedence)}

Definition statement

This place covers:

Illustrative example of subject matter classified in this group:

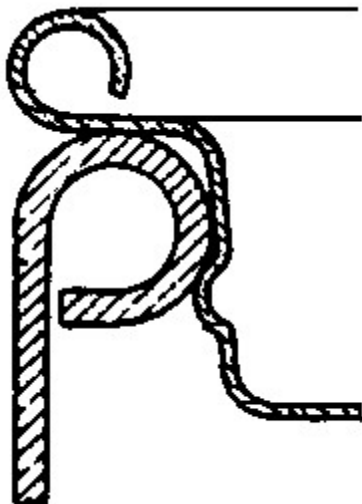

Special rules of classification

The use of available Indexing Codes is mandatory.

B65D 43/0212

{only on the outside, or a part turned to the outside, of the mouth
([B65D 43/0206](#) takes precedence)}

Definition statement

This place covers:

Illustrative example of subject matter classified in this group:

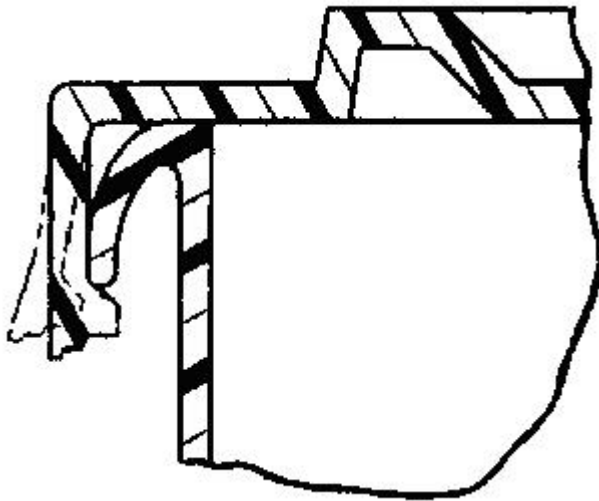
**Special rules of classification**

The use of available Indexing Codes is mandatory.

B65D 43/0214

{secured only by friction or gravity ([B65D 43/0204](#) takes precedence)}

Definition statement

This place covers:

Illustrative example of subject matter classified in this group:

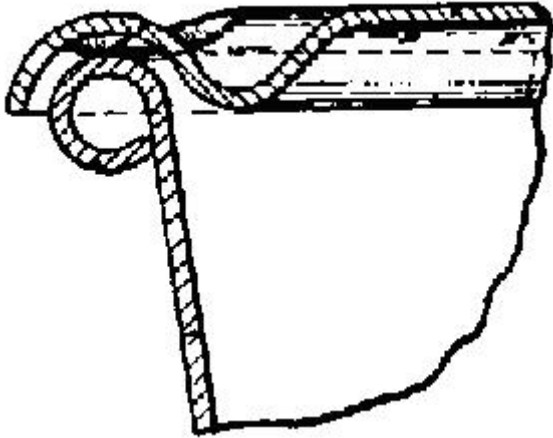

Special rules of classification

The use of available Indexing Codes is mandatory.

B65D 43/0216

{inside a peripheral U-shaped channel in the mouth of the container}

Definition statement

This place covers:

Illustrative example of subject matter classified in this group:

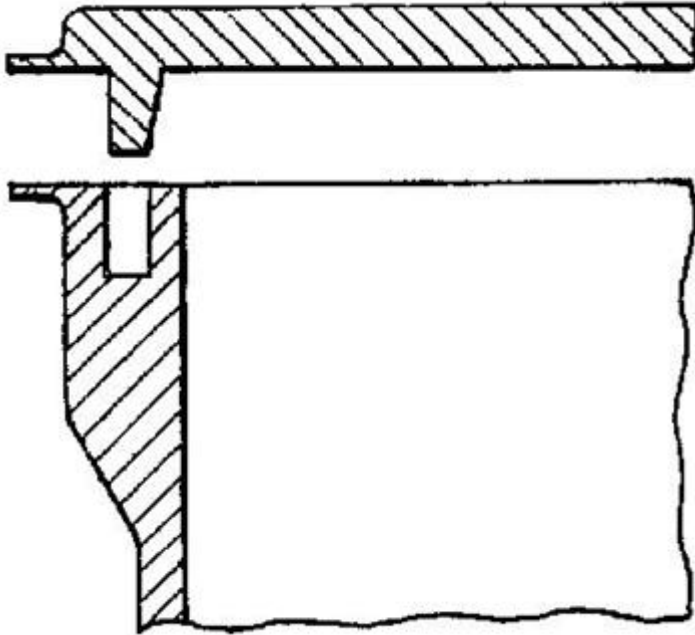

Special rules of classification

The use of available Indexing Codes is mandatory.

B65D 43/0218

{on both the inside and the outside of the mouth of the container
([B65D 43/0216](#) takes precedence)}

Definition statement

This place covers:

Illustrative example of subject matter classified in this group:

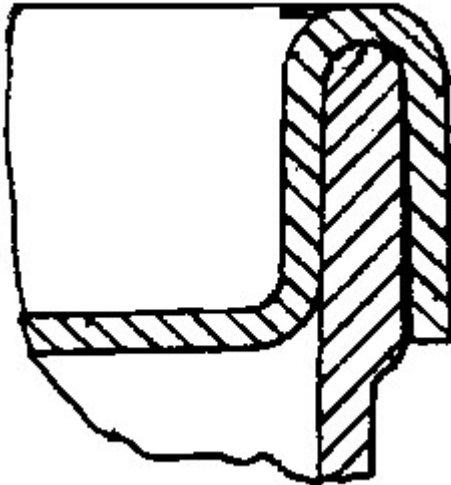
**Special rules of classification**

The use of available Indexing Codes is mandatory.

B65D 43/022

{only on the inside, or a part turned to the inside, of the mouth of the container
([B65D 43/0216](#) takes precedence)}

Definition statement

This place covers:

Illustrative example of subject matter classified in this group:

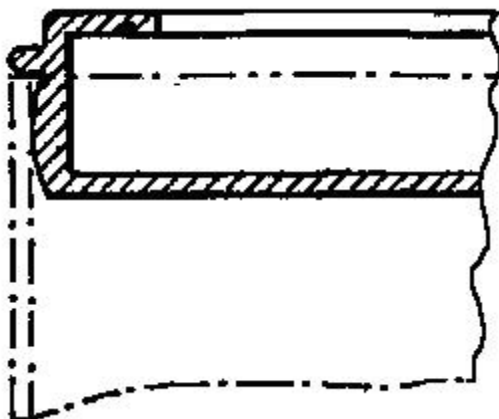

Special rules of classification

The use of available Indexing Codes is mandatory.

B65D 43/022

{only on the outside, or a part turned to the outside, of the mouth of the container ([B65D 43/0216](#) takes precedence)}

Definition statement

This place covers:

Illustrative example of subject matter classified in this group:

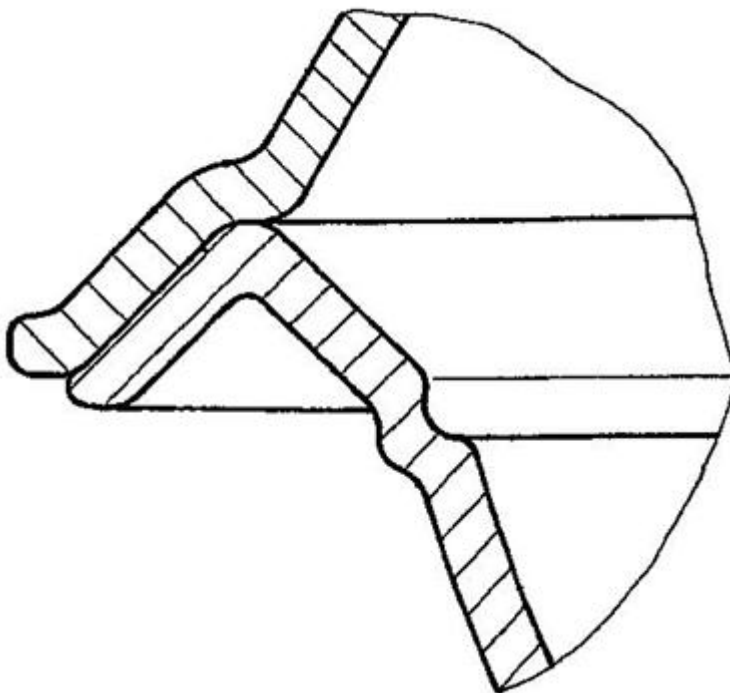
**Special rules of classification**

The use of available Indexing Codes is mandatory.

B65D 43/0225

{secured by rotation}

Special rules of classification

The use of available Indexing Codes is mandatory.

B65D 43/0227

{inside a peripheral U-shaped channel in the mouth of the container}

Definition statement

This place covers:

Illustrative example of subject matter classified in this group:

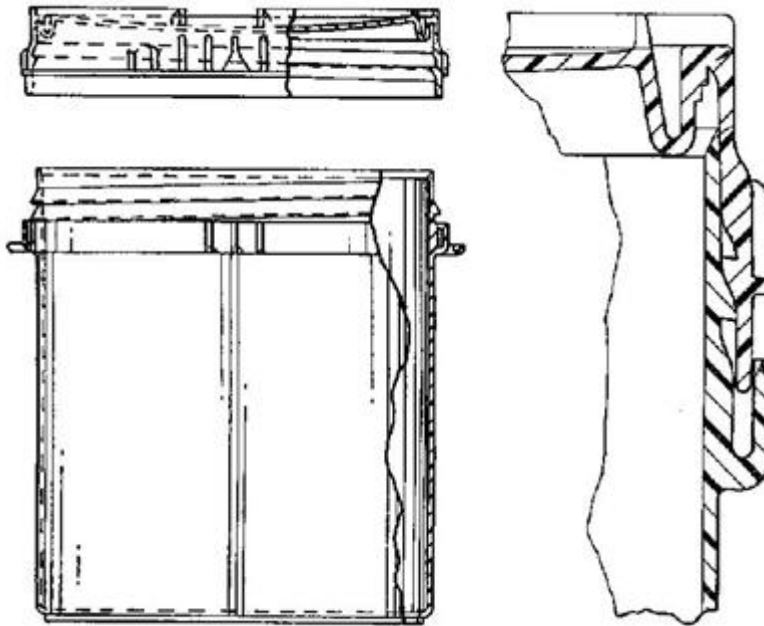

Special rules of classification

The use of available Indexing Codes is mandatory.

B65D 43/0229

{only on the inside, or a part turned to the inside, of the mouth of the container
([B65D 43/0227](#) takes precedence)}

Definition statement

This place covers:

Illustrative example of subject matter classified in this group:

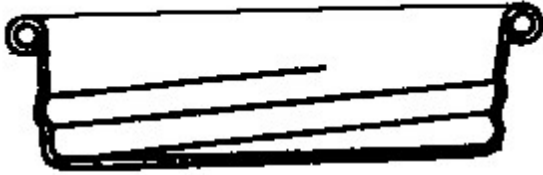

Special rules of classification

The use of available Indexing Codes is mandatory.

B65D 43/0231

{only on the outside, or a part turned to the outside, of the mouth of the container ([B65D 43/0227](#) takes precedence)}

Definition statement

This place covers:

Illustrative example of subject matter classified in this group:

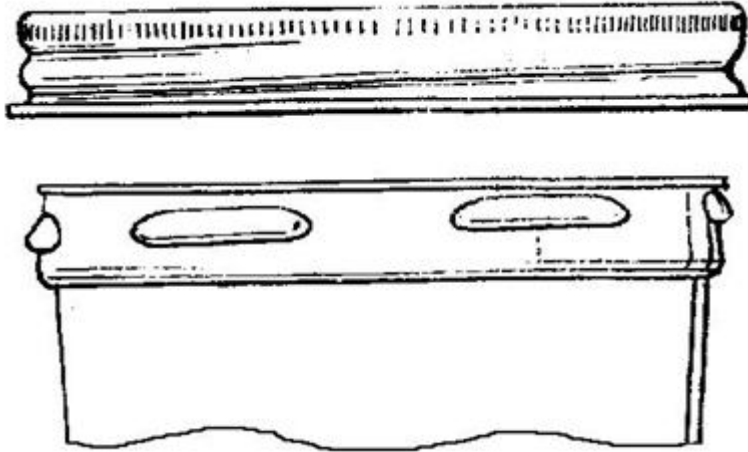

Special rules of classification

The use of available Indexing Codes is mandatory.

B65D 43/0233**{secured by rolling or other plastic deformation}****Definition statement***This place covers:*

Illustrative example of subject matter classified in this group:

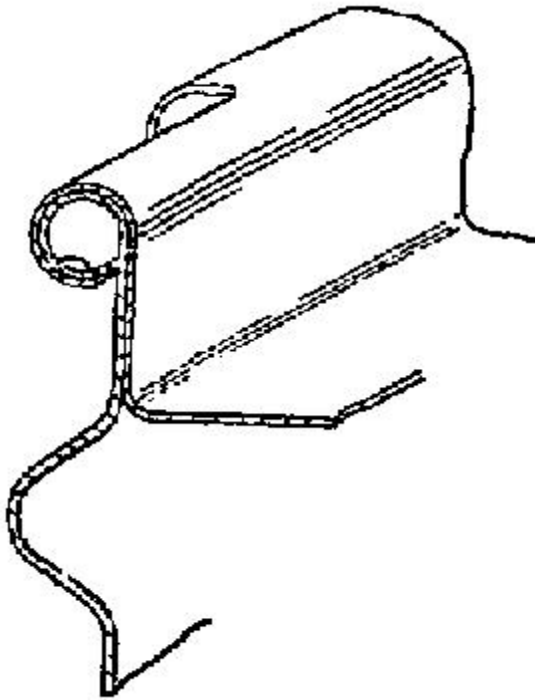
**References*****Informative references****Attention is drawn to the following places, which may be of interest for search:*

Closures secured by folding or rolling and pressing	B65D 17/08
---	----------------------------

Special rules of classification

The use of available Indexing Codes is mandatory.

B65D 43/0235**{with integral tamper element}****References*****Limiting references****This place does not cover:*

Tamper element integral with the container	B65D 43/0202 , B65D 2401/10
--	--

Special rules of classification

The use of available Indexing Codes is mandatory.

B65D 43/0237

{secured by snapping over beads or projections before removal of the tamper element}

References**Limiting references**

This place does not cover:

Tamper element integral with the container	B65D 43/0202 , B65D 2401/10
--	--

Special rules of classification

The use of available Indexing Codes is mandatory.

B65D 43/0239

{inside a peripheral U-shaped channel in the mouth of the container}

Definition statement

This place covers:

Illustrative example of subject matter classified in this group:

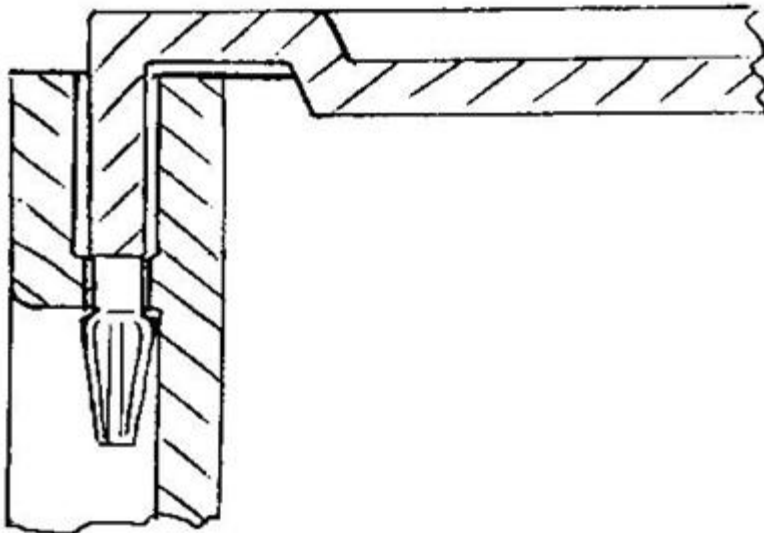
**Special rules of classification**

The use of available Indexing Codes is mandatory.

B65D 43/0241

{leaving only an inside snap after removal of the tamper element}

Definition statement

This place covers:

Illustrative example of subject matter classified in this group:

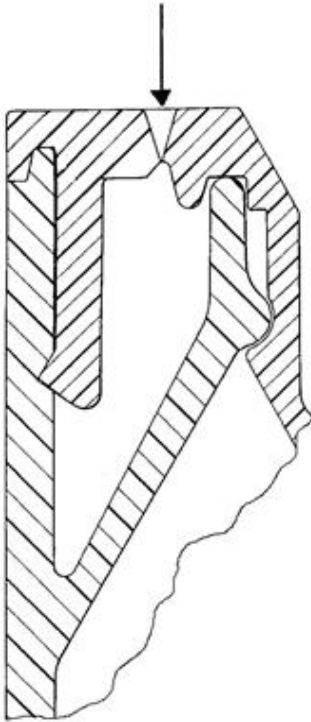
**Special rules of classification**

The use of available Indexing Codes is mandatory.

B65D 43/0243

{leaving friction on both the inside and the outside after removal of the tamper element}

Special rules of classification

The use of available Indexing Codes is mandatory.

B65D 43/0245

{leaving only an inside friction after removal of the tamper element}

Special rules of classification

The use of available Indexing Codes is mandatory.

B65D 43/0247

{leaving only an outside friction after removal of the tamper element}

Special rules of classification

The use of available Indexing Codes is mandatory.

B65D 43/0249

{on both the inside and the outside of the mouth of the container
([B65D 43/0239](#) takes precedence)}

Definition statement

This place covers:

Illustrative example of subject matter classified in this group:

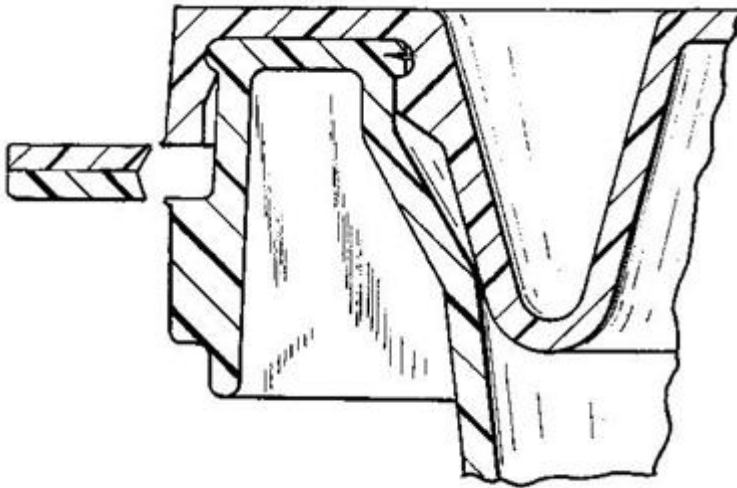

Special rules of classification

The use of available Indexing Codes is mandatory.

B65D 43/0252

{leaving only an inside snap after removal of the tamper element}

Definition statement

This place covers:

Illustrative example of subject matter classified in this group:

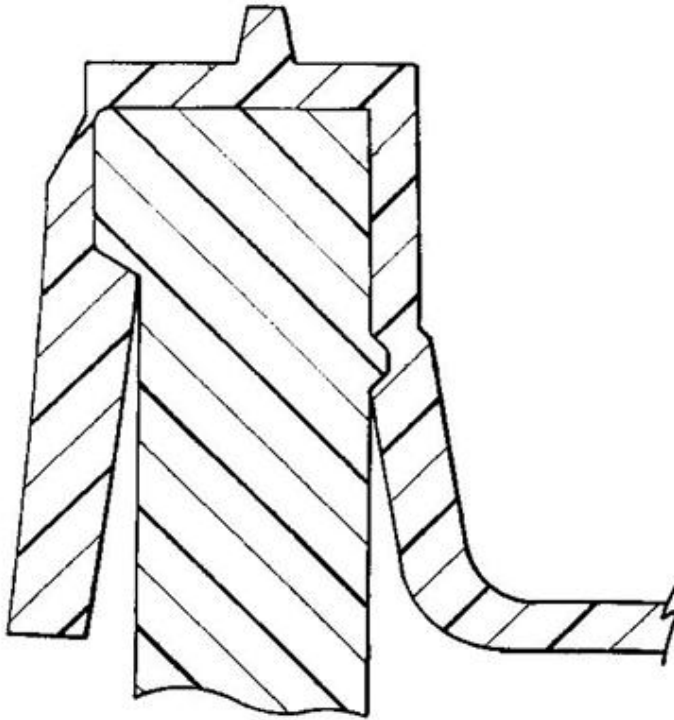

Special rules of classification

The use of available Indexing Codes is mandatory.

B65D 43/0254

{only on the inside, or a part turned to the inside, of the mouth of the container
([B65D 43/0239](#) takes precedence)}

Definition statement

This place covers:

Illustrative example of subject matter classified in this group:

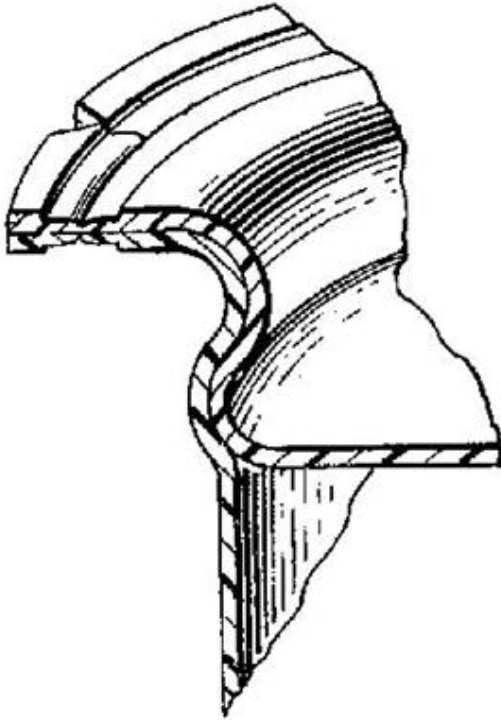

Special rules of classification

The use of available Indexing Codes is mandatory.

B65D 43/0256

{only on the outside, or a part turned to the outside, of the mouth of the container ([B65D 43/0239](#) takes precedence)}

Definition statement

This place covers:

Illustrative example of subject matter classified in this group:

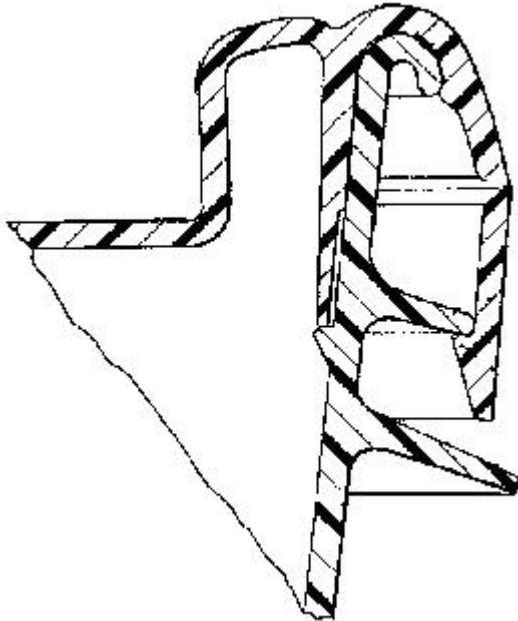
**Special rules of classification**

The use of available Indexing Codes is mandatory.

B65D 43/0258

{leaving friction on both the inside and the outside after removal of the tamper element}

Special rules of classification

The use of available Indexing Codes is mandatory.

B65D 43/026

{leaving only an inside friction after removal of the tamper element}

Special rules of classification

The use of available Indexing Codes is mandatory.

B65D 43/0262

{leaving only an outside friction after removal of the tamper element}

Special rules of classification

The use of available Indexing Codes is mandatory.

B65D 43/0264

{secured only by friction or gravity before removal of the tamper element
([B65D 43/0237](#) takes precedence)}

References**Limiting references**

This place does not cover:

Tamper element integral with the container	B65D 43/0214 , B65D 2401/10
--	--

Special rules of classification

The use of available Indexing Codes is mandatory.

B65D 43/0266

{inside a peripheral U-shaped channel in the mouth of the container}

Definition statement

This place covers:

Illustrative example of subject matter classified in this group:

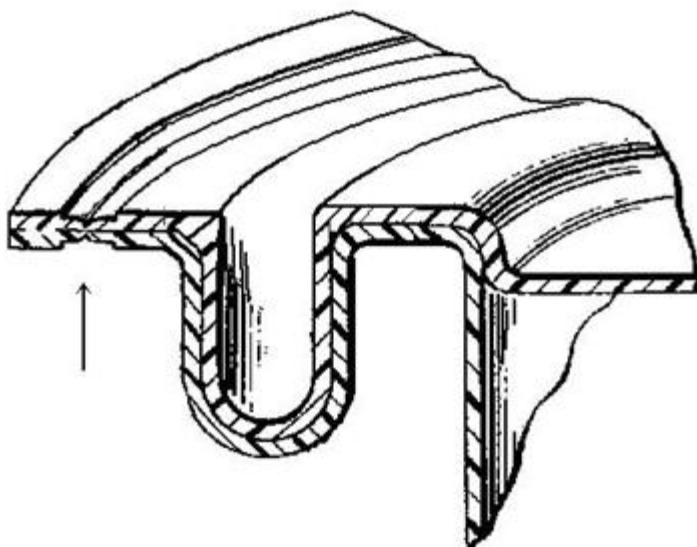

Special rules of classification

The use of available Indexing Codes is mandatory.

B65D 43/0268

{on both the inside and the outside of the mouth of the container
([B65D 43/0266](#) takes precedence)}

Definition statement

This place covers:

Illustrative example of subject matter classified in this group:

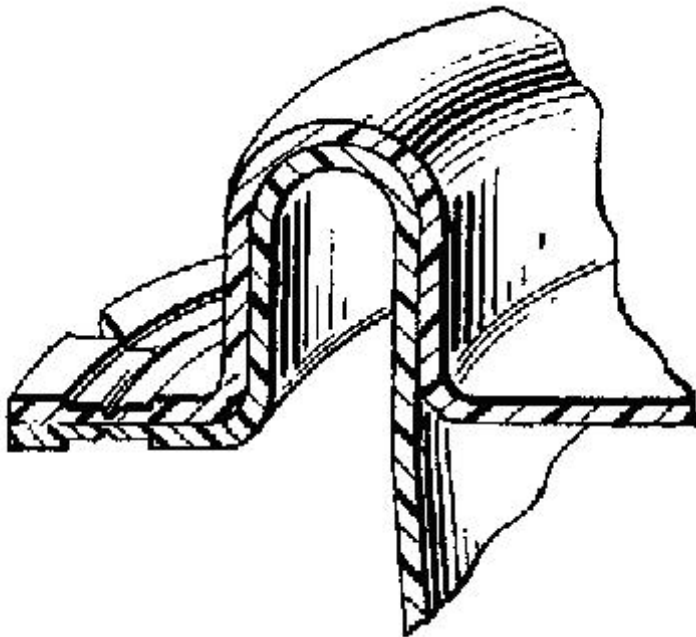

Special rules of classification

The use of available Indexing Codes is mandatory.

B65D 43/027

{leaving only an inside friction after removal of the tamper element}

Definition statement

This place covers:

Illustrative example of subject matter classified in this group:

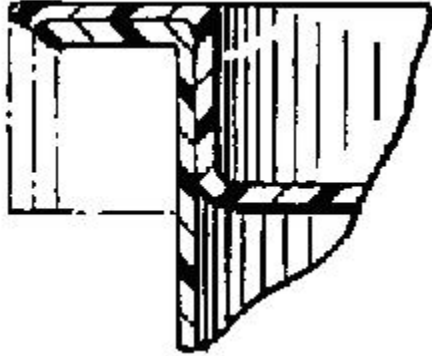

Special rules of classification

The use of available Indexing Codes is mandatory.

B65D 43/0272

{only on the inside, or a part turned to the inside, of the mouth of the container
([B65D 43/0266](#) takes precedence)}

Definition statement

This place covers:

Illustrative example of subject matter classified in this group:

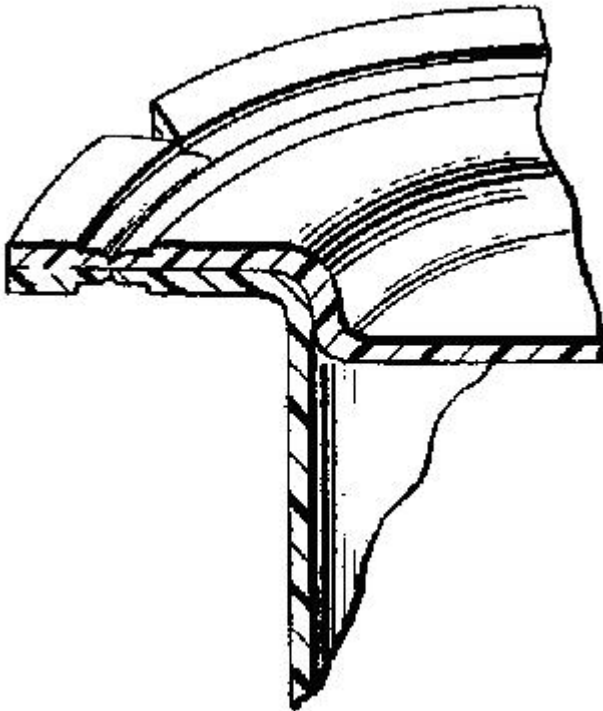

Special rules of classification

The use of available Indexing Codes is mandatory.

B65D 43/0274

{only on the outside, or a part turned to the outside, of the mouth of the container ([B65D 43/0266](#) takes precedence)}

Definition statement

This place covers:

Illustrative example of subject matter classified in this group:

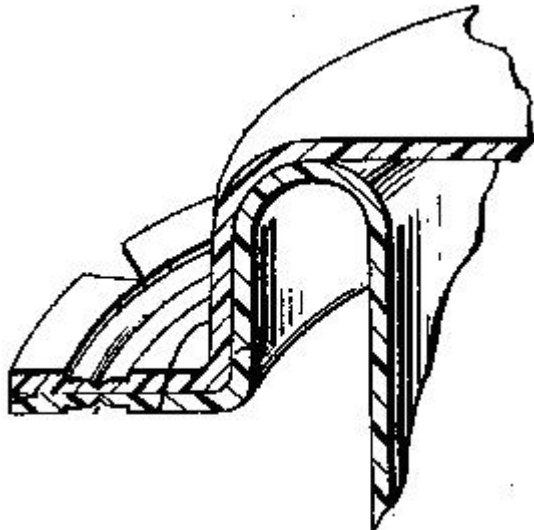
**References****Limiting references**

This place does not cover:

Inside a peripheral U-shaped channel in the mouth of the container	B65D 43/0266
--	------------------------------

Special rules of classification

The use of available Indexing Codes is mandatory.

B65D 43/0277

{secured by rotation before removal of the tamper element}

References**Limiting references**

This place does not cover:

Tamper element integral with the container	B65D 43/0225 , B65D 2401/10
--	--

Special rules of classification

The use of available Indexing Codes is mandatory.

B65D 43/0283

{only on the outside, or a part turned to the outside, of the mouth of the container ([B65D 43/0279](#) takes precedence)}

Definition statement

This place covers:

Illustrative example of subject matter classified in this group:

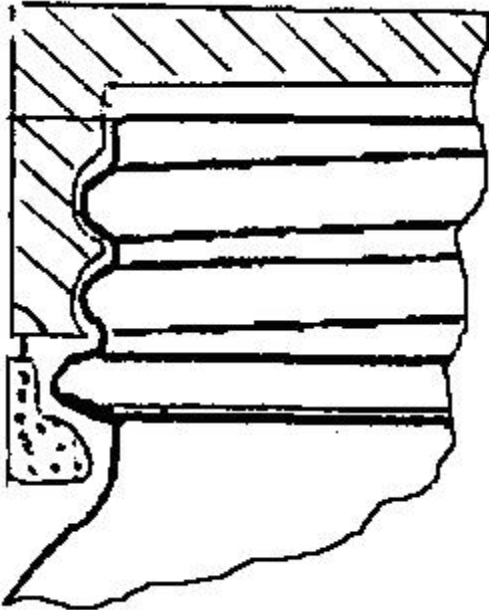
**References****Limiting references**

This place does not cover:

Inside a peripheral U-shaped channel in the mouth of the container	B65D 43/0279
--	------------------------------

Special rules of classification

The use of available Indexing Codes is mandatory.

B65D 43/0289

{leaving only an inside snap after removal of the tamper element}

Definition statement

This place covers:

Illustrative example of subject matter classified in this group:

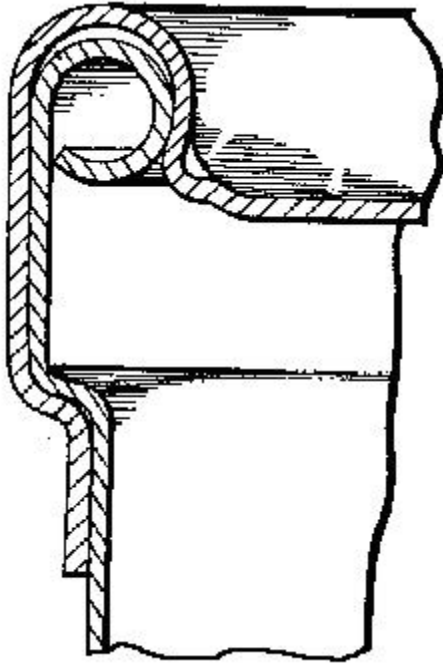

Special rules of classification

The use of available Indexing Codes is mandatory.

B65D 43/0291

{leaving only an outside snap after removal of the tamper element}

Definition statement

This place covers:

Illustrative example of subject matter classified in this group:

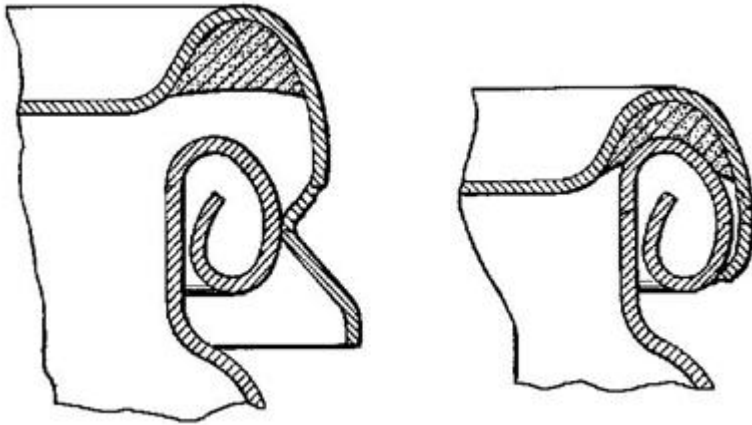
**Special rules of classification**

The use of available Indexing Codes is mandatory.

B65D 43/0293

{leaving friction on both the inside and the outside after removal of the tamper element}

Definition statement

This place covers:

Illustrative example of subject matter classified in this group:

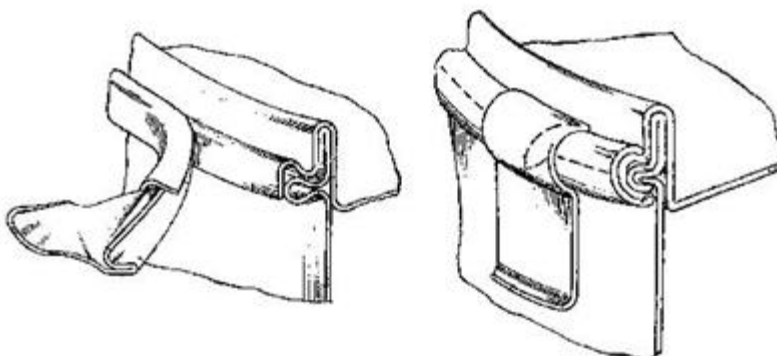
**Special rules of classification**

The use of available Indexing Codes is mandatory.

B65D 43/0295

{leaving only an inside friction after removal of the tamper element}

Definition statement

This place covers:

Illustrative example of subject matter classified in this group:

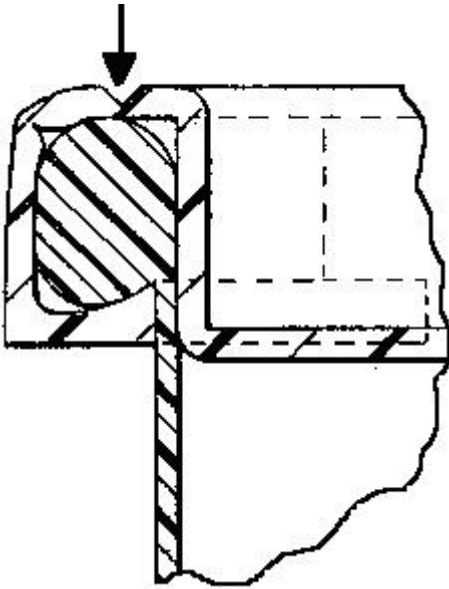
**Special rules of classification**

The use of available Indexing Codes is mandatory.

B65D 43/0297

{leaving only an outside friction after removal of the tamper element}

Definition statement

This place covers:

Illustrative example of subject matter classified in this group:

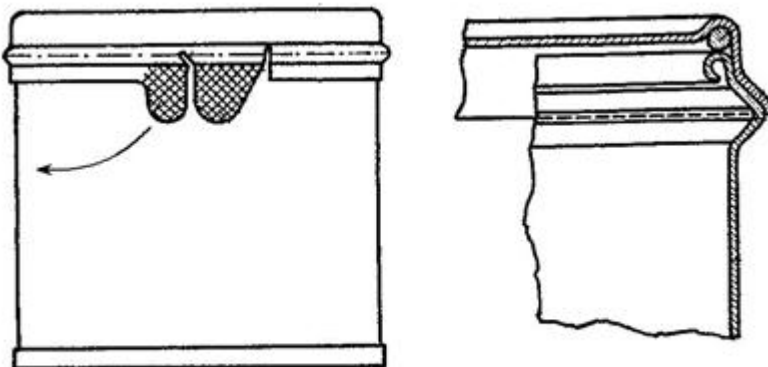

Special rules of classification

The use of available Indexing Codes is mandatory.

B65D 43/12**guided for removal by sliding****Definition statement**

This place covers:

Illustrative example of subject matter classified in this group:

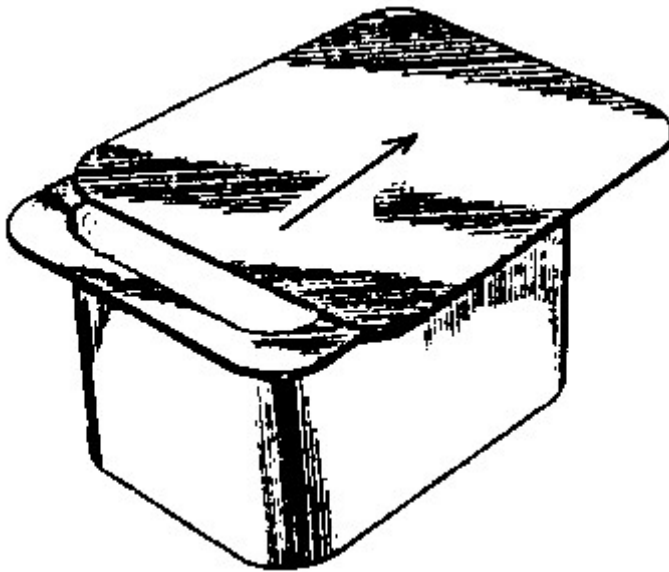
**References****Informative references**

Attention is drawn to the following places, which may be of interest for search:

Linearly slidable	B65D 43/20
-------------------	----------------------------

Special rules of classification

The use of available Indexing Codes is mandatory.

B65D 43/14**Non-removable lids or covers****Special rules of classification**

The use of available Indexing Codes is mandatory.

B65D 43/16

hinged for upward or downward movement ({cigar or cigarette receptacles [A24F 15/00](#); suitcases, étuis [A45C](#); casings for cosmetic substances with hinged covers [A45D 40/22](#); toolboxes [B25H 3/02](#); } hinges of door or similar type [E05D](#) {; boxes for switchboards with hinged covers [H02B 1/066](#)})

Definition statement

This place covers:

Illustrative example of subject matter classified in this group:

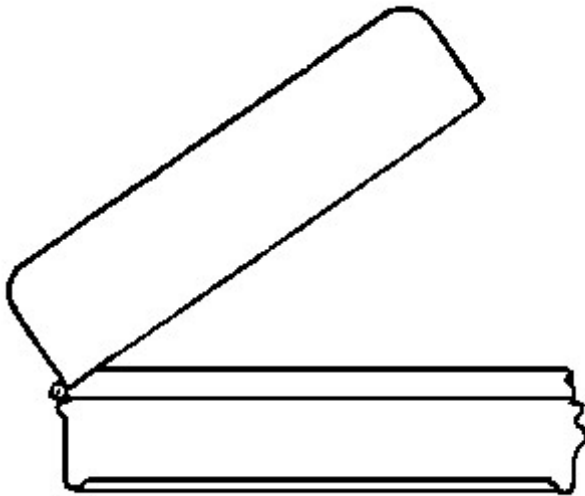

Special rules of classification

The use of available Indexing Codes is mandatory.

B65D 43/161

{comprising two or more cover sections hinged one to another}

Definition statement

This place covers:

Illustrative example of subject matter classified in this group:

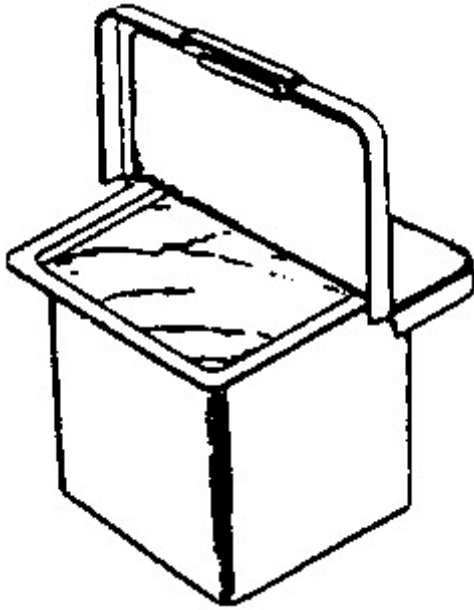

References

Informative references

Attention is drawn to the following places, which may be of interest for search:

Hinges without elastic bias located within a flat surface of the base element	B65D 47/0847
---	------------------------------

Special rules of classification

The use of available Indexing Codes is mandatory.

B65D 43/162

{the container, the lid and the hinge being made of one piece ([B65D 43/161](#) takes precedence)}

Definition statement

This place covers:

Illustrative example of subject matter classified in this group:

**References****Limiting references**

This place does not cover:

Non-removable lids or covers comprising two or more cover sections hinged one to another	B65D 43/161
--	-----------------------------

Informative references

Attention is drawn to the following places, which may be of interest for search:

Details of packages formed by enclosing articles or materials in preformed containers	B65D 75/22
---	----------------------------

Special rules of classification

The use of available Indexing Codes is mandatory.

B65D 43/163

{the container and the lid being made separately ([B65D 43/161](#) takes precedence)}

References**Limiting references**

This place does not cover:

Non-removable lids or covers comprising two or more cover sections hinged one to another	B65D 43/161
--	-----------------------------

Special rules of classification

The use of available Indexing Codes is mandatory.

B65D 43/164

{and connected by interfitting hinge elements integrally with the container and the lid formed respectively}

Definition statement

This place covers:

Illustrative example of subject matter classified in this group:

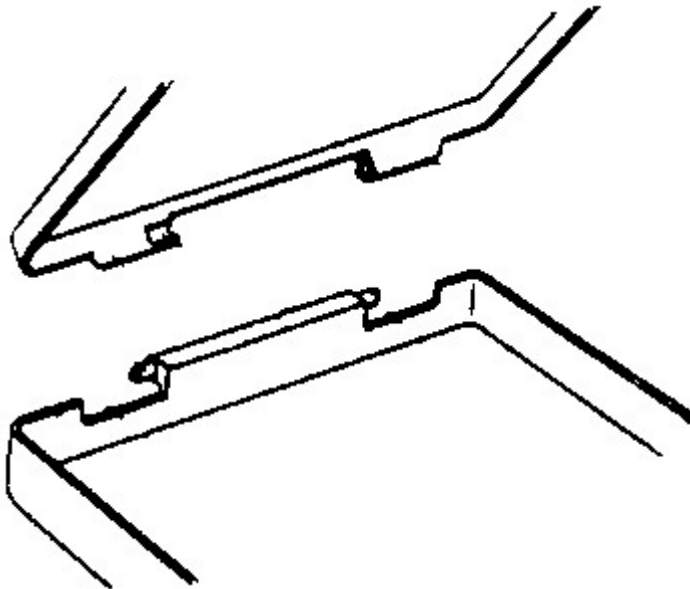
**Special rules of classification**

The use of available Indexing Codes is mandatory.

B65D 43/165

{these elements being assembled by a separate pin-like member}

Definition statement

This place covers:

Illustrative example of subject matter classified in this group:

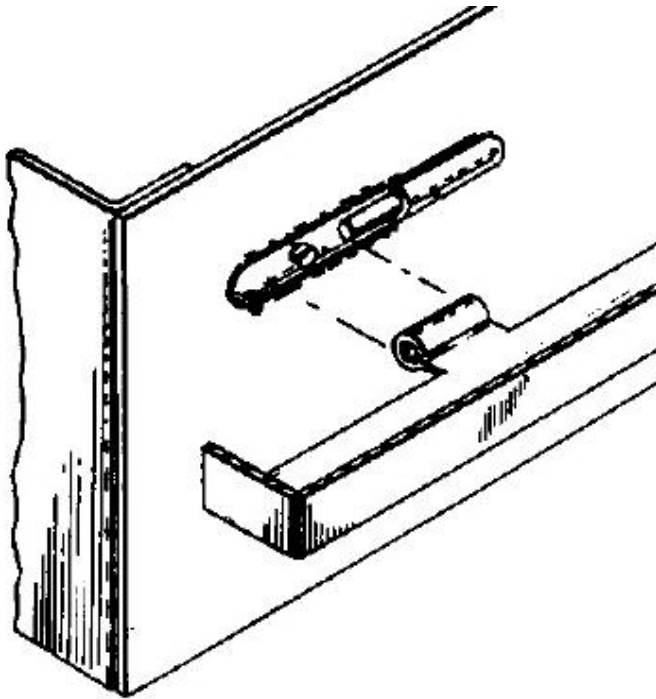

Special rules of classification

The use of available Indexing Codes is mandatory.

B65D 43/166

{and connected by separate interfitting hinge elements fixed to the container and the lid respectively}

Definition statement

This place covers:

Illustrative example of subject matter classified in this group:

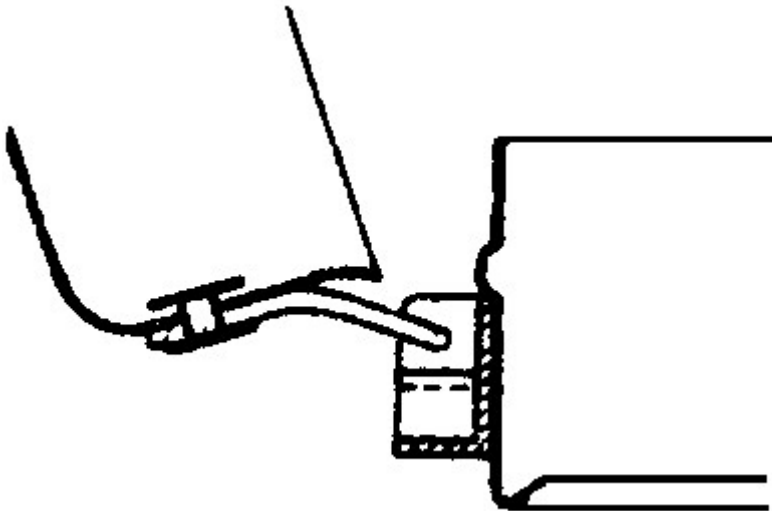
**Special rules of classification**

The use of available Indexing Codes is mandatory.

B65D 43/167

{these elements being assembled by a separate pin-like member}

Definition statement

This place covers:

Illustrative example of subject matter classified in this group:

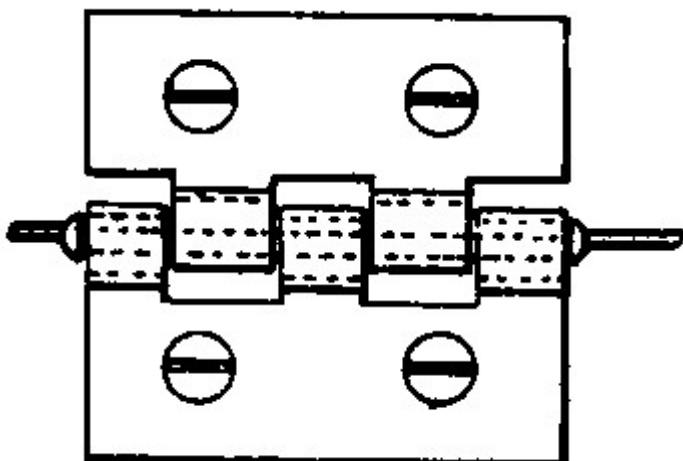

Special rules of classification

The use of available Indexing Codes is mandatory.

B65D 43/168

{and connected by one or more hinges formed by a separate, single container and a flexible, band-like element fixed to the container and the lid}

Definition statement

This place covers:

Illustrative example of subject matter classified in this group:

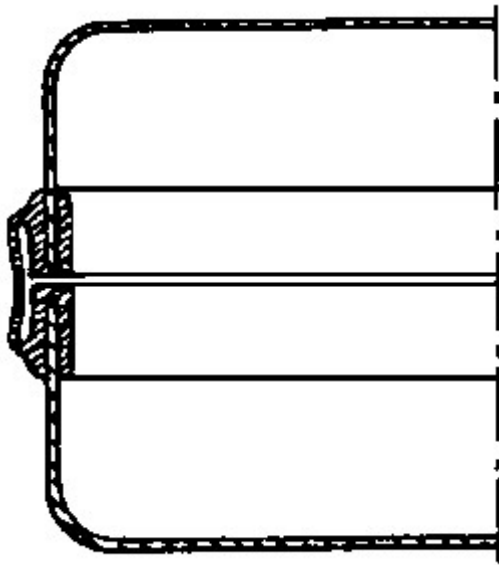
**Special rules of classification**

The use of available Indexing Codes is mandatory.

B65D 43/169

{the lid, the hinge and the element connecting them to the container being made of one piece}

Definition statement

This place covers:

Illustrative example of subject matter classified in this group:

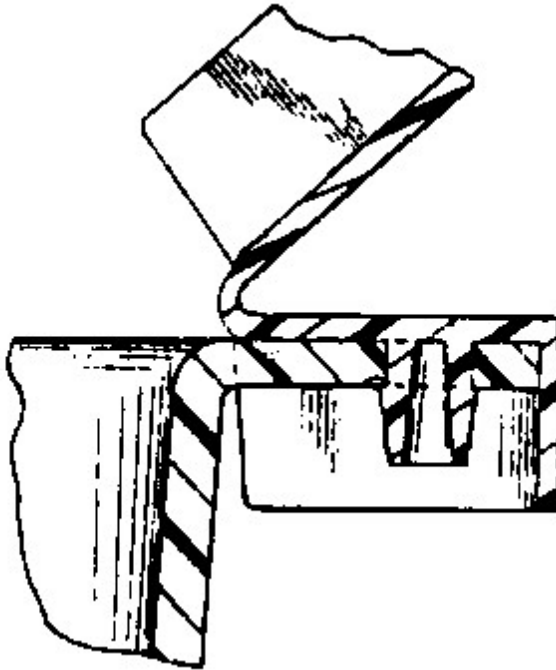

Special rules of classification

The use of available Indexing Codes is mandatory.

B65D 43/18

pivoted for movement in plane of container mouth

Definition statement

This place covers:

Illustrative example of subject matter classified in this group:

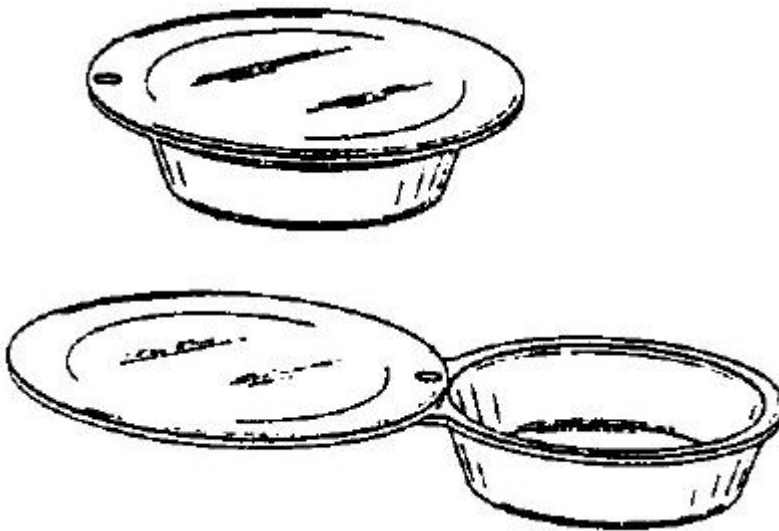

Special rules of classification

The use of available Indexing Codes is mandatory.

B65D 43/20

linearly slidable

Definition statement

This place covers:

Illustrative example of subject matter classified in this group:

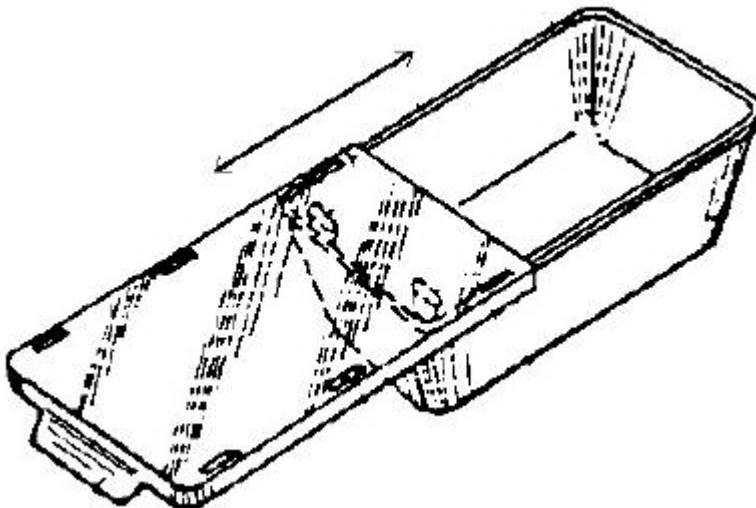

References

Informative references

Attention is drawn to the following places, which may be of interest for search:

Guided for removal by sliding	B65D 43/12
-------------------------------	----------------------------

Special rules of classification

The use of available Indexing Codes is mandatory.

B65D 43/22

Devices for holding in closed position, e.g. clips

Definition statement

This place covers:

Illustrative example of subject matter classified in this group:

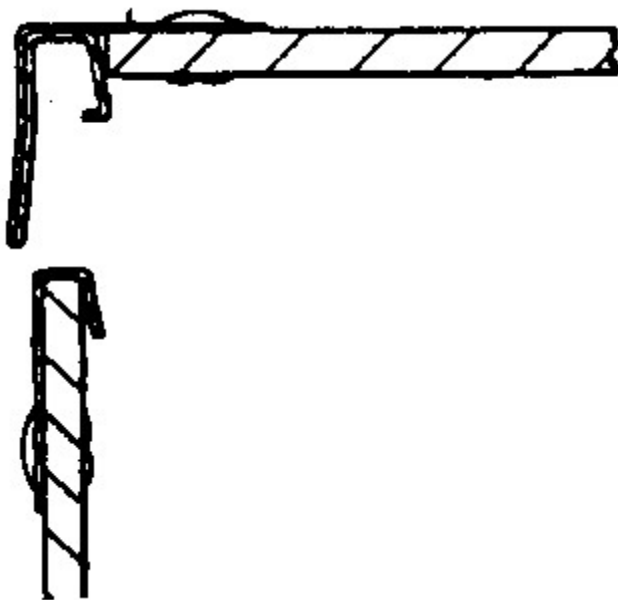

References

Limiting references

This place does not cover:

Releasable fastenings clips	F16B 2/20
-----------------------------	---------------------------

Informative references

Attention is drawn to the following places, which may be of interest for search:

Non-removable lids or covershinged for upward or downward movement	B65D 45/16
Means for locking the closure in closed position	B65D 2251/1016

Special rules of classification

The use of available Indexing Codes is mandatory.

B65D 43/24

Devices for retaining in open position {(holding lids in open position in general [E05C 17/00](#); hinges with means for holding open [E05D 11/10](#)}

Definition statement

This place covers:

Illustrative example of subject matter classified in this group:

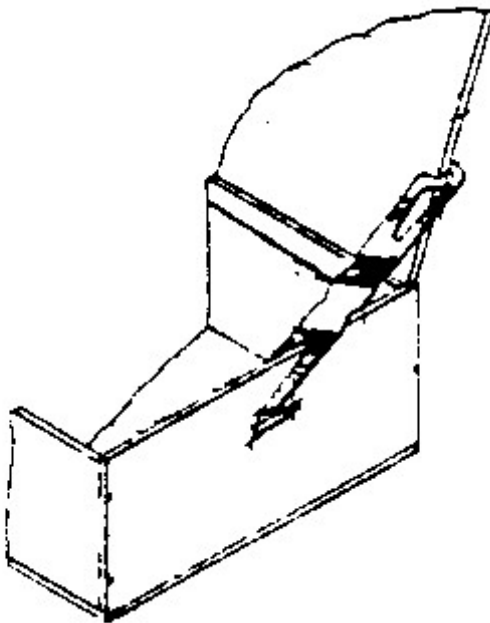
**References****Limiting references**

This place does not cover:

For hinged lids	B65D 43/16 , B65D 2251/1008
-----------------	--

Special rules of classification

The use of available Indexing Codes is mandatory.

B65D 43/26

Mechanisms for opening or closing, e.g. pedal-operated {(for refuse receptacles [B65F 1/1623](#))}

Definition statement

This place covers:

Illustrative example of subject matter classified in this group:

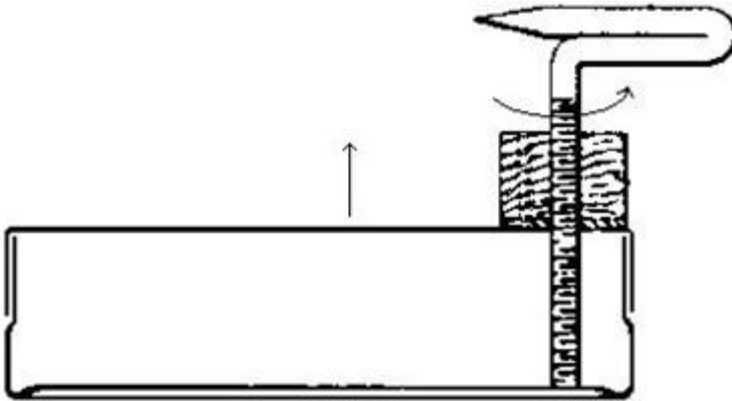
**Special rules of classification**

The use of available Indexing Codes is mandatory.

B65D 43/262

{pedal-operated}

References**Limiting references**

This place does not cover:

Pedal-operated lids for refuse receptacles	B65F 1/163
--	----------------------------

Special rules of classification

The use of available Indexing Codes is mandatory.

B65D 43/265

{consisting of levers pivoting perpendicularly to container axis, e.g. butterfly levers}

Definition statement

This place covers:

Illustrative example of subject matter classified in this group:

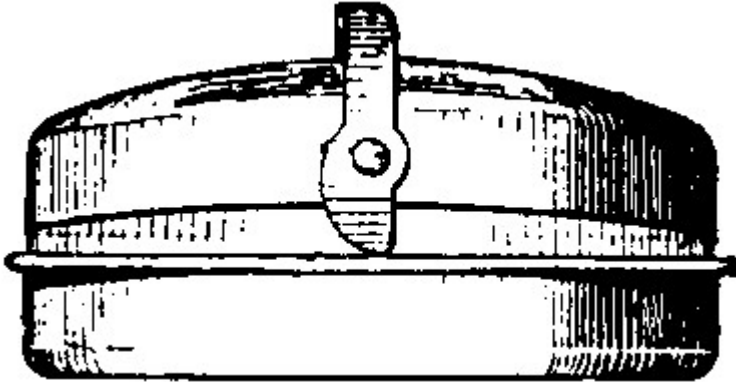

References

Informative references

Attention is drawn to the following places, which may be of interest for search:

Lever-operated	B65D 45/34
----------------	----------------------------

Special rules of classification

The use of available Indexing Codes is mandatory.

B65D 43/267

{consisting of levers pivoting radially to container axis}

Definition statement

This place covers:

Illustrative example of subject matter classified in this group:

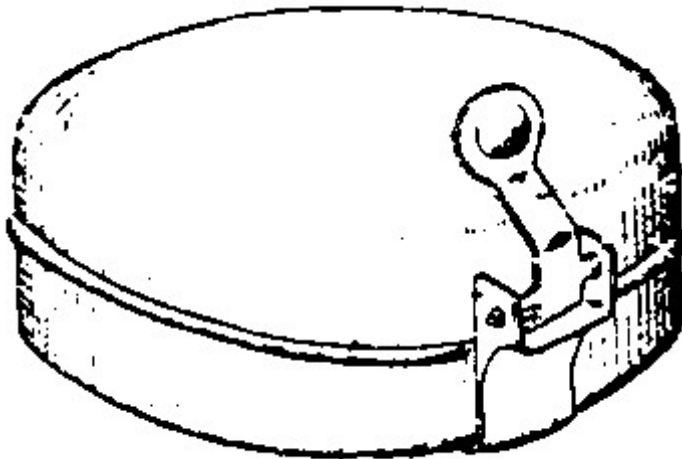
**References****Informative references**

Attention is drawn to the following places, which may be of interest for search:

Lever-operated	B65D 45/34
----------------	----------------------------

Special rules of classification

The use of available Indexing Codes is mandatory.

B65D 45/00

Clamping or other pressure-applying devices for securing or retaining closure members (screw-threaded or bayonet connections between stoppers or caps and containers [B65D 39/08](#), [B65D 41/04](#), [B65D 41/34](#); expansible stoppers [B65D 39/12](#); for pressure vessels in general [F16J 13/00](#))

References**Limiting references**

This place does not cover:

Shrinkable sleeves or members	B65D 55/0854
For flexible membrane, local	B65D 77/2004
For flexible membrane, peripheral ring	B65D 77/202

Informative references

Attention is drawn to the following places, which may be of interest for search:

Closure flaps or lids attached to, or incorporated in, containers, or foldable or erectable container blanks, made of paper	B65D 3/00 , B65D 5/00
Closure walls of containers specially constructed to be opened by cutting, piercing, or tearing of wall portions	B65D 17/00
Applying closure members to bottles, jars, or similar containers	B67B
Covers or similar closure members, for pressure vessels in general	F16J 13/00

B65D 45/02

for applying axial pressure to engage closure with sealing surface

References**Limiting references**

This place does not cover:

Combining axial and radial pressure	B65D 45/32
-------------------------------------	----------------------------

B65D 45/025

{Closure members opened by lever action and maintained closed by spring action ([B65D 45/04](#) takes precedence)}

Definition statement

This place covers:

Illustrative example of subject matter classified in this group:

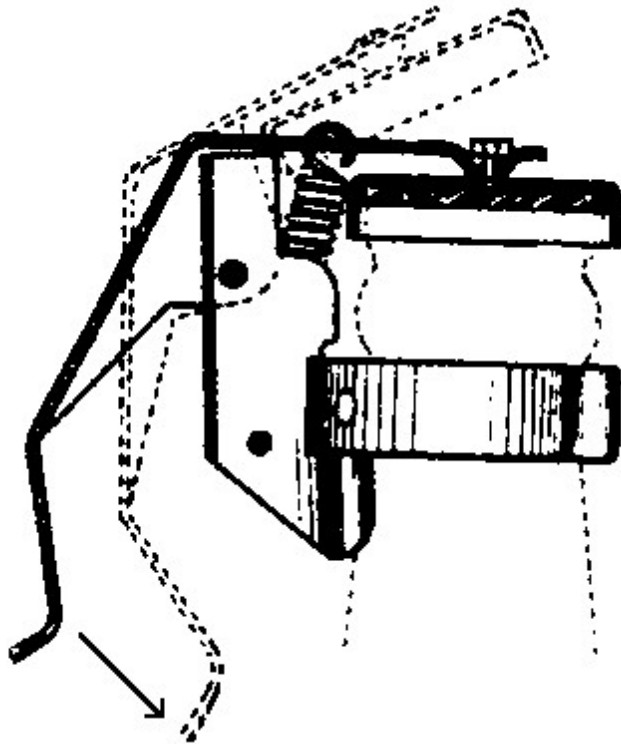
**References****Limiting references**

This place does not cover:

Comprising U-shaped or bifurcated members coacting with containers	B65D 45/04
--	----------------------------

B65D 45/04

comprising U-shaped or bifurcated members coacting with containers {these members remaining connected with the closure and with the container when the container is open}, e.g. pivoted bails

References**Informative references**

Attention is drawn to the following places, which may be of interest for search:

Hand-operated members for controlling discharge with slide valves having a rotational or helicoidal movement	B65D 47/261
--	-----------------------------

B65D 45/06

associated with toggle levers, e.g. swing stopper arrangements

Definition statement

This place covers:

Illustrative example of subject matter classified in this group:

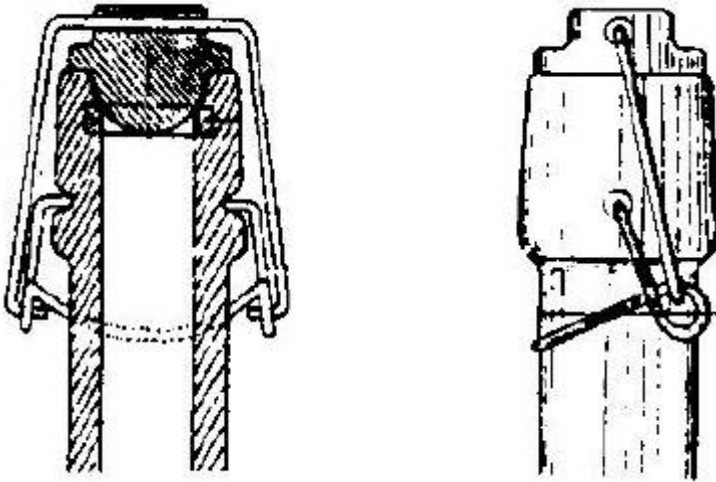
**References****Informative references**

Attention is drawn to the following places, which may be of interest for search:

Forming levers of links by working wire	B21F 45/04
Toggle fasteners in general	E05C 19/14

B65D 45/08

incorporating springs

Definition statement

This place covers:

Illustrative example of subject matter classified in this group:

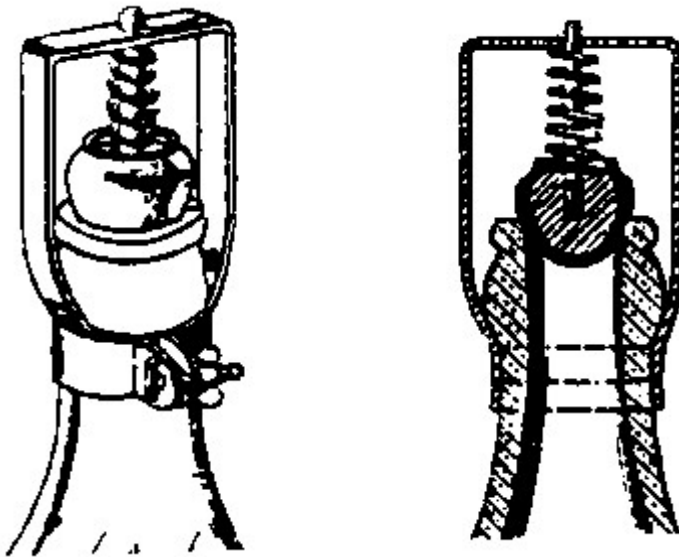

B65D 45/10

incorporating tightening screws

Definition statement

This place covers:

Illustrative example of subject matter classified in this group:

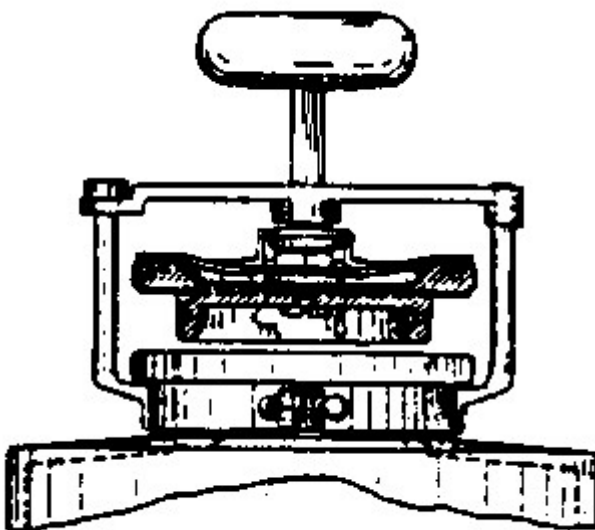

B65D 45/12

associated with locking levers engaging rack teeth for varying the applied pressure

Definition statement

This place covers:

Illustrative example of subject matter classified in this group:

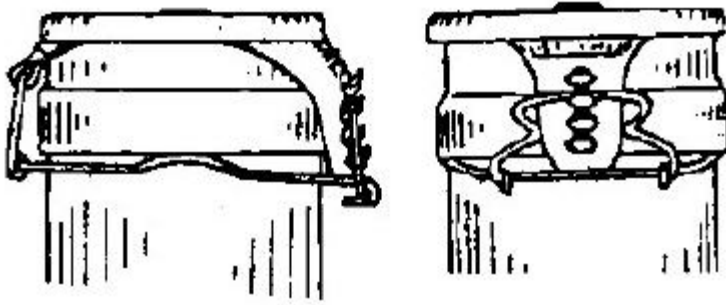

B65D 45/14

coating with inclined grooves in container wall for varying the applied pressure

Definition statement

This place covers:

Illustrative example of subject matter classified in this group:

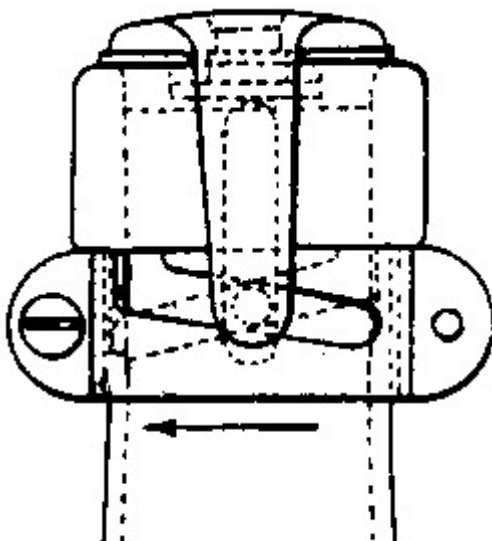

B65D 45/16

Clips, hooks, or clamps {which are removable, or which remain connected either with the closure or with the container when the container is open}, e.g. C-shaped (U-shaped or bifurcated members [B65D 45/04](#))

References**Limiting references**

This place does not cover:

Releasable fastenings clips	F16B 2/20
-----------------------------	---------------------------

Informative references

Attention is drawn to the following places, which may be of interest for search:

Devices for holding in closed position	B65D 43/22
--	----------------------------

B65D 45/18

of snap-over type

Definition statement

This place covers:

Illustrative example of subject matter classified in this group:

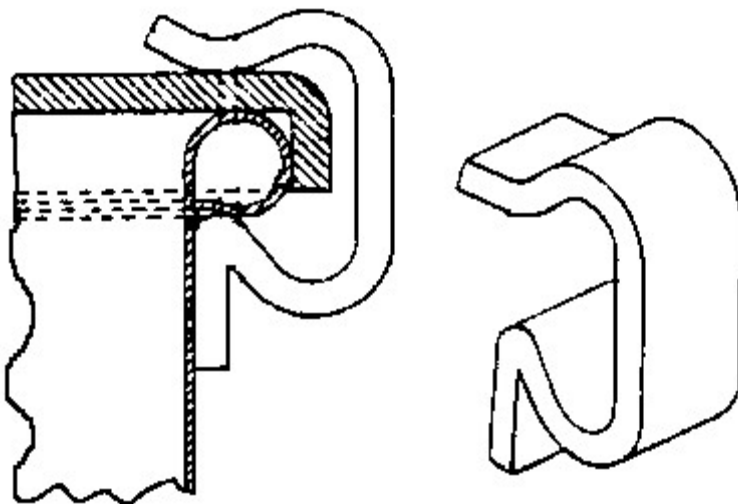

B65D 45/22

resilient

Definition statement

This place covers:

Illustrative example of subject matter classified in this group:

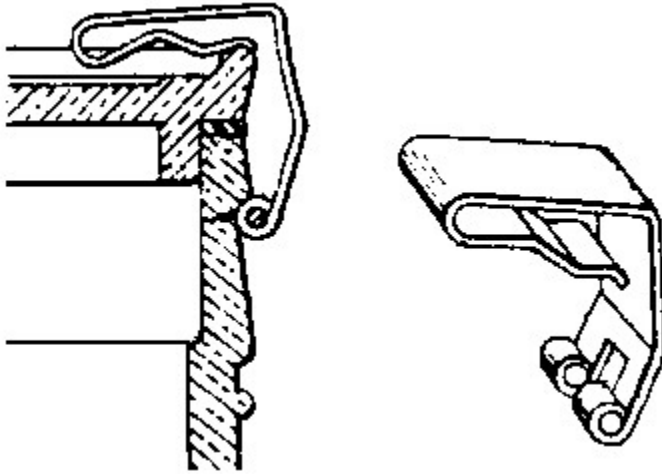

References

Limiting references

This place does not cover:

Elastic bolts	E05C 19/06
Toggle fasteners	E05C 19/14

B65D 45/24

incorporating pressure-applying means, e.g. screws or toggles

Definition statement

This place covers:

Illustrative example of subject matter classified in this group:

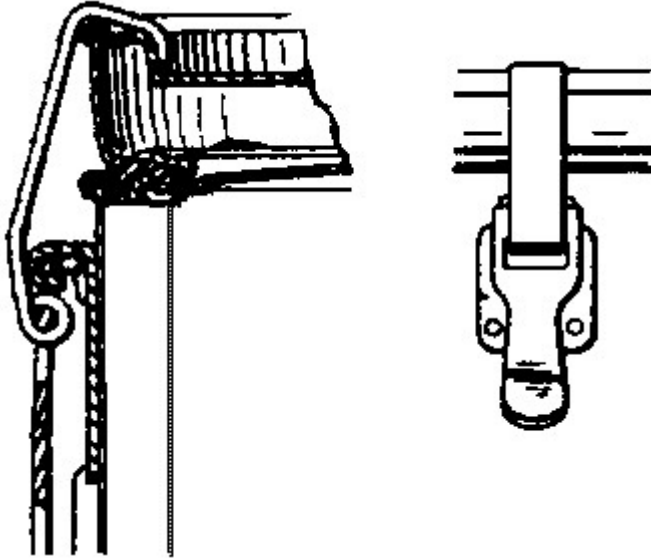
**References****Limiting references**

This place does not cover:

Toggle latch	E05C 19/14
--------------	----------------------------

B65D 45/26

incorporating tensioning chains

Definition statement

This place covers:

Illustrative example of subject matter classified in this group:

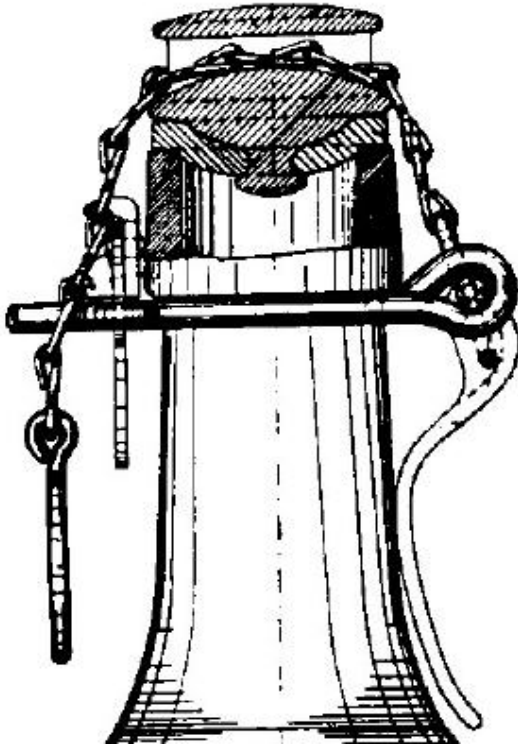

B65D 45/28

Elongated members, e.g. leaf springs, located substantially at right angles to closure axis and acting between the face of the closure and abutments on container

Definition statement

This place covers:

Illustrative example of subject matter classified in this group:

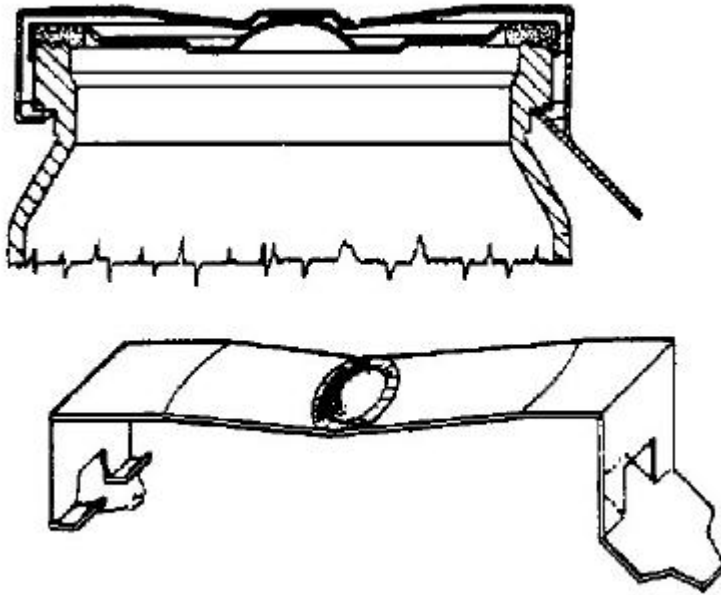

B65D 45/30

Annular members, e.g. with snap-over action or screw-threaded {([B65D 45/32](#) takes precedence)}

Definition statement

This place covers:

Illustrative example of subject matter classified in this group:

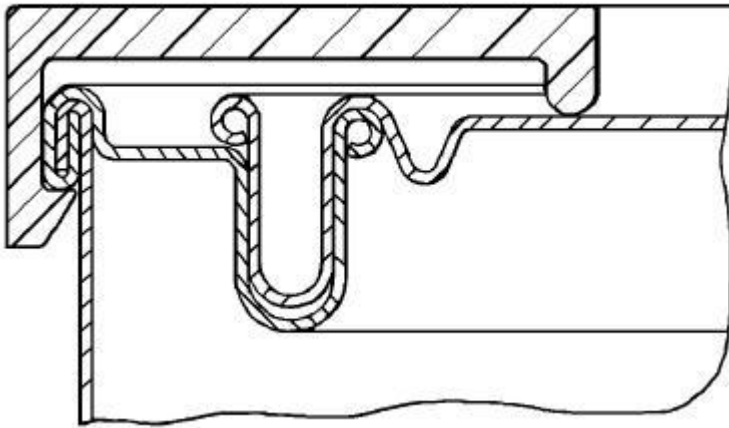
**References****Limiting references**

This place does not cover:

Combining axial and radial pressure	B65D 45/32
Non-destructible cap-like collars for maintaining rigid discs in sealing engagement with container	B65D 51/145
Destructible elements for maintaining closure on container	B65D 55/08

B65D 45/305

{Screw-threaded or bayonet-type annular members cooperating with an intermediate ring ([B65D 41/08](#), [B65D 51/14](#) takes precedence)}

Definition statement

This place covers:

Illustrative example of subject matter classified in this group:

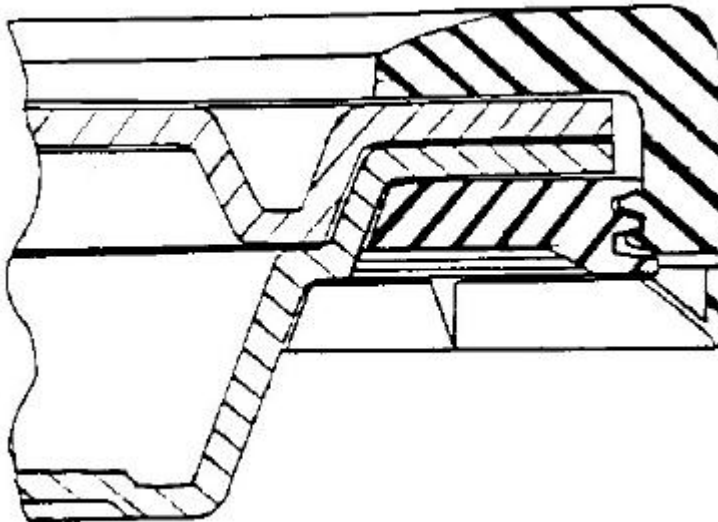
**References****Limiting references**

This place does not cover:

Threaded or like caps or cap-like covers secured by rotation engaging a threaded ring clamped on the external periphery of the neck or wall	B65D 41/08
Rigid discs or spherical members adapted to be held in sealing engagement with mouth of container, e.g. closure plates for preserving jars	B65D 51/14

Informative references

Attention is drawn to the following places, which may be of interest for search:

Clamping device being an annular member moved axially to clamp the closure by using radial pressure the annular member being screw-threaded or bayonet-type	B65D 45/325
---	-----------------------------

B65D 45/32

for applying radial {or radial and axial} pressure, e.g. contractible bands encircling closure member

Definition statement

This place covers:

Illustrative example of subject matter classified in this group:

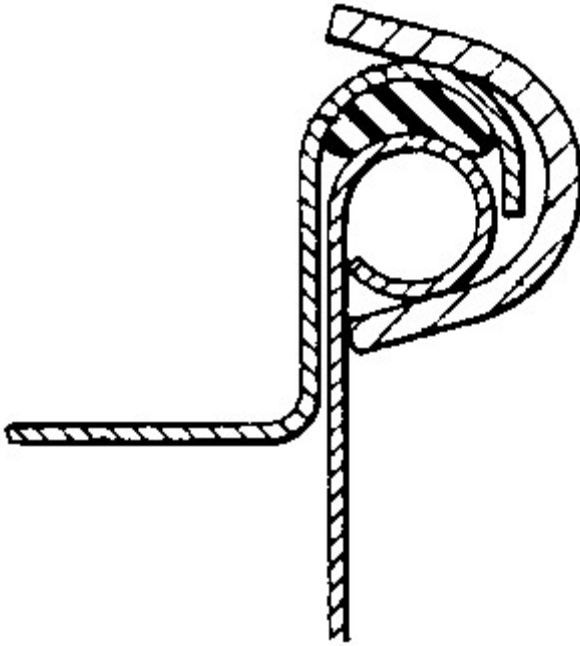
**References****Limiting references**

This place does not cover:

Destructible elements for maintaining closure on container	B65D 55/08
Locking pins exerting a radial force	B65D 55/10

B65D 45/322

{the clamping device being an annular member moved axially to clamp the closure by using radial pressure ([B65D 55/0863](#), [B65D 55/0872](#) take precedence)}

Definition statement

This place covers:

Illustrative example of subject matter classified in this group:

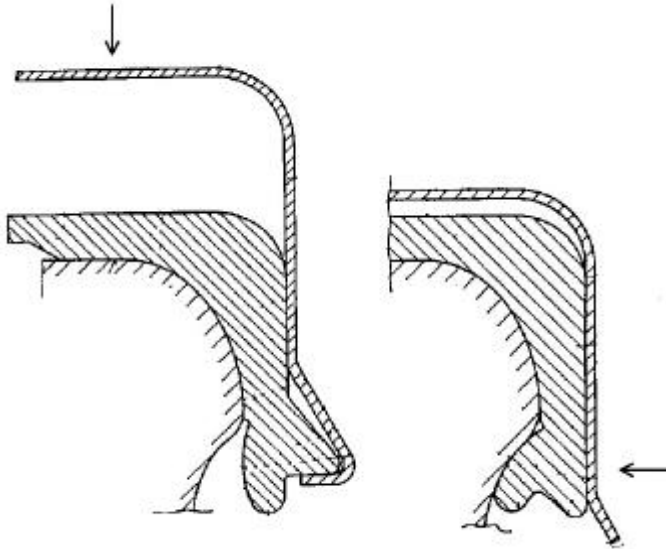
**References****Limiting references**

This place does not cover:

Plastic snap-on cap-like collars having frangible parts	B65D 55/0863
Destructible rigid elements snapping into annular grooves in closure for maintaining closure on container	B65D 55/0872

B65D 45/325

{the annular member being screw-threaded or bayonet-type ([B65D 51/14](#) takes precedence)}

Definition statement

This place covers:

Illustrative example of subject matter classified in this group:

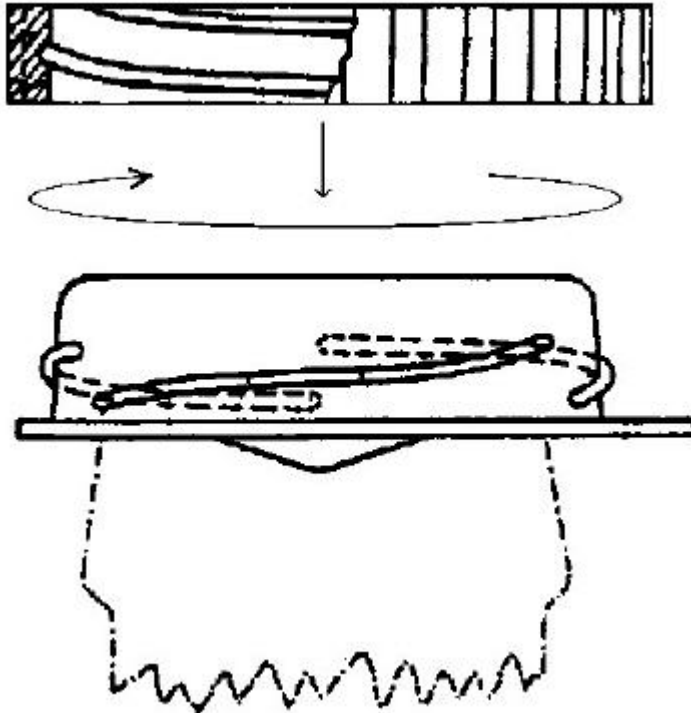
**References****Limiting references**

This place does not cover:

Rigid discs or spherical members adapted to be held in sealing engagement with mouth of container	B65D 51/14
---	----------------------------

Informative references

Attention is drawn to the following places, which may be of interest for search:

Threaded or like caps or cap-like covers secured by rotation engaging a threaded ring clamped on the external periphery of the neck or wall	B65D 41/08
Screw-threaded or bayonet-type annular members cooperating with an intermediate ring	B65D 45/305

B65D 45/327

{the annular member applying radial pressure against the inner surface of the container wall ([B65D 55/0863](#), [B65D 55/0872](#) take precedence)}

Definition statement

This place covers:

Illustrative example of subject matter classified in this group:

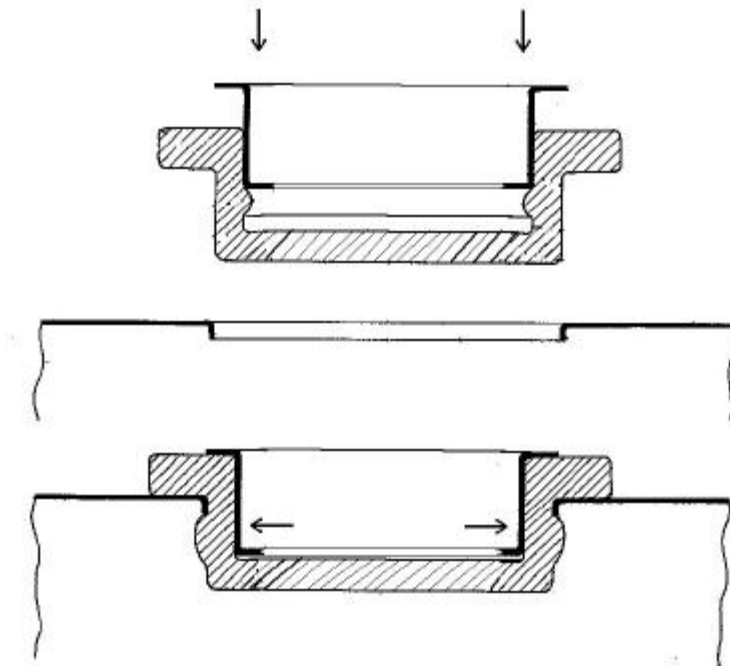
**References****Limiting references**

This place does not cover:

Plastic snap-on cap-like collars having frangible parts	B65D 55/0863
Destructible rigid elements snapping into annular grooves in closure for maintaining closure on container	B65D 55/0872

Informative references

Attention is drawn to the following places, which may be of interest for search:

Closures arranged within necks or pouring openings or in discharge apertures expansible	B65D 39/12
---	----------------------------

B65D 45/34**lever-operated****Definition statement**

This place covers:

Illustrative example of subject matter classified in this group:

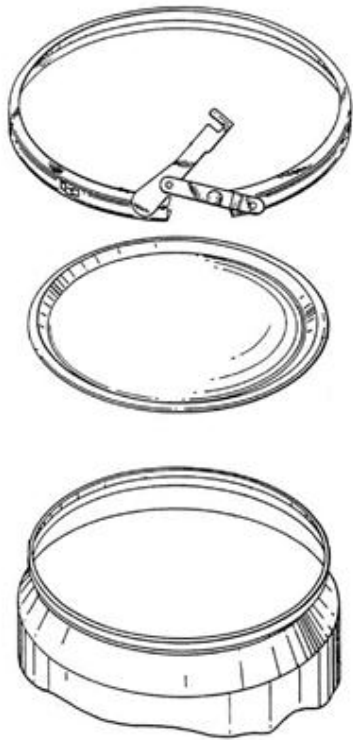
**References****Limiting references**

This place does not cover:

Toggle fasteners	E05C 19/14 , F16L 33/12 , F16L 37/20
------------------	---

Informative references

Attention is drawn to the following places, which may be of interest for search:

Mechanisms for opening or closing consisting of levers pivoting perpendicularly to container axis	B65D 43/265
Mechanisms for opening or closing consisting of levers pivoting radially to container axis	B65D 43/267

B65D 45/345

{Lever-operated contractible or expansible band, the lever moving in the plane of the band}

Definition statement

This place covers:

Illustrative example of subject matter classified in this group:

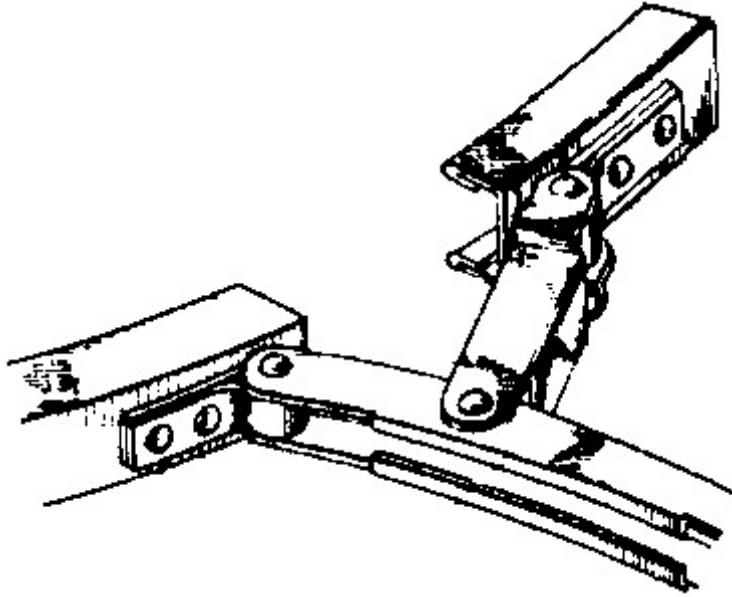
**References****Informative references**

Attention is drawn to the following places, which may be of interest for search:

Mechanisms for opening or closing consisting of levers pivoting perpendicularly to container axis	B65D 43/265
---	-----------------------------

B65D 47/00

Closures with filling and discharging, or with discharging, devices (dispensers for liquid soap [A47K 5/12](#); desk equipment for applying liquid by contact with surfaces [B43M 11/00](#); fluid delivery valves in general [F16K 21/00](#))

References**Limiting references**

This place does not cover:

Oil cans with discharging devices	F16N 3/04
-----------------------------------	---------------------------

Application-oriented references

Examples of places where the subject matter of this place is covered when specially adapted, used for a particular purpose, or incorporated in a larger system:

Office equipment for applying liquid by contact to surfaces	B43M 11/00
---	----------------------------

Informative references

Attention is drawn to the following places, which may be of interest for search:

Fluid-delivery valves in general	F16K 21/00
----------------------------------	----------------------------

B65D 47/02

for initially filling and for preventing subsequent refilling

References**Limiting references**

This place does not cover:

Arrangements or devices for preventing refilling of containers	B65D 49/00
--	----------------------------

B65D 47/043

{with pouring baffles, e.g. for controlling the flow}

Definition statement

This place covers:

Illustrative example of subject matter classified in this group:

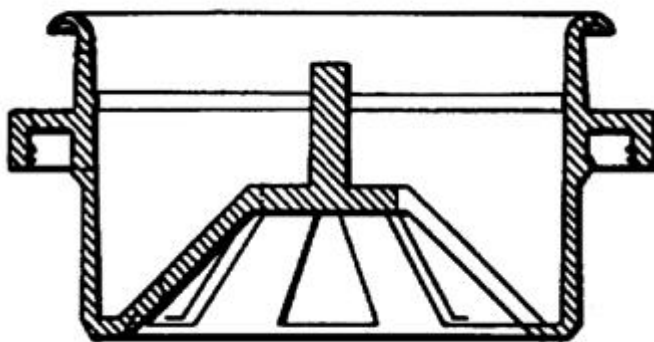

e.g. limiting the cross-sectional area of the spout

References**Limiting references**

This place does not cover:

With means for venting	B65D 47/32
------------------------	----------------------------

B65D 47/046

{Closures with swivelling dispensing devices (containers with swivelling devices comprising a bottom wall and two side walls [B65D 25/525](#))}

Definition statement

This place covers:

Illustrative example of subject matter classified in this group:

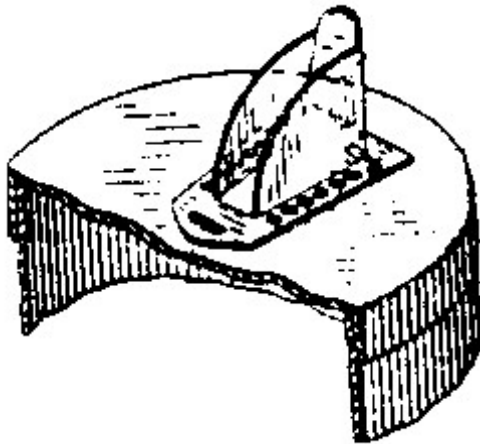
**References****Informative references**

Attention is drawn to the following places, which may be of interest for search:

Spouts formed by deforming or tearing scored or incised parts of the side-wall of containers combined with swivelling devices having a bottom-wall and two side-walls	B65D 5/744
---	----------------------------

B65D 47/06

with pouring spouts or tubes; with discharge nozzles or passages (with slidable spouts [B65D 47/26](#))

References**Limiting references**

This place does not cover:

Drinking lids with valves	B65D 47/2018
Means for facilitating drinking from table glasses or vessels	A47G 19/2266
Caulking nozzles	B05C 17/00503

Informative references

Attention is drawn to the following places, which may be of interest for search:

Nozzles or spouts	B65D 25/40
-------------------	----------------------------

Special rules of classification

The use of available Indexing Codes is mandatory.

B65D 47/061

{with telescopic, retractable or reversible spouts, tubes or nozzles}

Definition statement

This place covers:

Illustrative example of subject matter classified in this group:

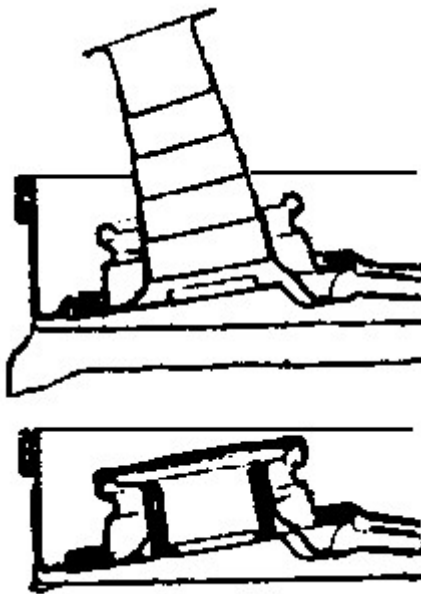
**References****Limiting references**

This place does not cover:

Caulking nozzles	B05C 17/00503
------------------	-------------------------------

Informative references

Attention is drawn to the following places, which may be of interest for search:

Telescopic or retractable nozzles or spouts	B65D 25/44
---	----------------------------

B65D 47/063**{with flexible parts}****Definition statement***This place covers:*

Illustrative example of subject matter classified in this group:

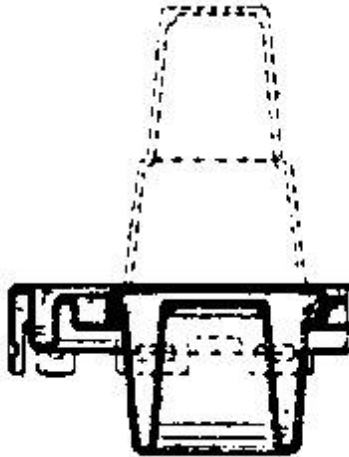
**References*****Informative references****Attention is drawn to the following places, which may be of interest for search:*

Telescopic or retractable nozzles or spouts	B65D 25/44
---	----------------------------

B65D 47/065**{with hinged, foldable or pivotable spouts}****Definition statement***This place covers:*

Illustrative example of subject matter classified in this group:



References

Limiting references

This place does not cover:

Caulking nozzles	B05C 17/00503
------------------	-------------------------------

Informative references

Attention is drawn to the following places, which may be of interest for search:

Hinged integral or attached nozzles or spouts	B65D 25/46
---	----------------------------

B65D 47/066

{the spout being either flexible or having a flexible wall portion, whereby the spout is foldable between a dispensing and a non-dispensing position ([B65D 47/2043](#) takes precedence)}

Definition statement

This place covers:

Illustrative example of subject matter classified in this group:

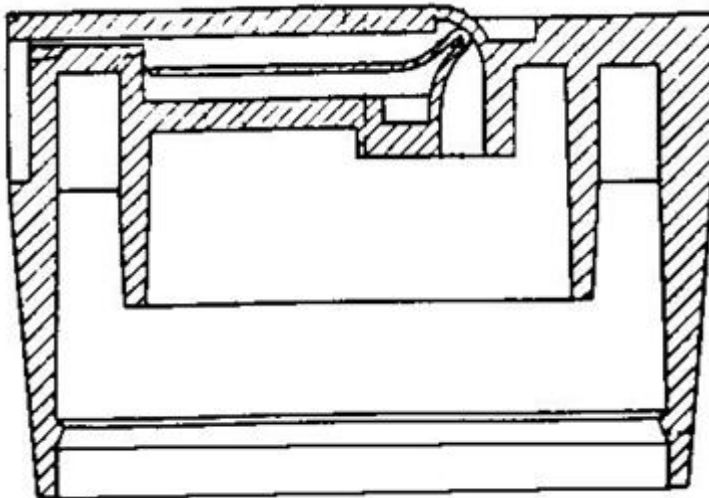

References

Limiting references

This place does not cover:

Separate element being formed by an overcap which constricts a spout, the spout being either pushed into alignment with, or pushed through, an opening in the overcap upon rotation of the latter	B65D 47/2043
---	------------------------------

Informative references

Attention is drawn to the following places, which may be of interest for search:

Hinged integral or attached nozzles or spouts, the spout being either flexible or having a flexible wall portion, whereby the spout is foldable between a dispensing and a non-dispensing position	B65D 25/465
Hand-operated members for controlling discharge formed by a rigid spout outlet opened by tilting of the spout outlet	B65D 47/2006

B65D 47/068

{with removable spouts which can be plugged in a discharging and in a closing position}

Definition statement

This place covers:

Illustrative example of subject matter classified in this group:

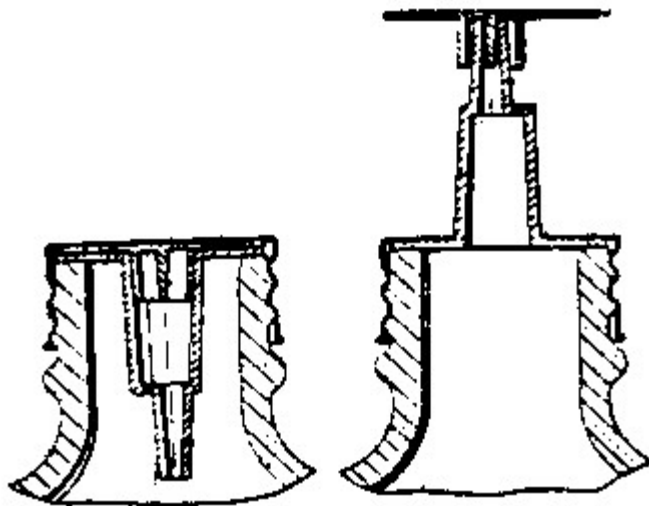
**References****Limiting references**

This place does not cover:

Caulking nozzles	B05C 17/00503
------------------	-------------------------------

Informative references

Attention is drawn to the following places, which may be of interest for search:

Separable nozzles or spouts arranged to be plugged in two alternate positions	B65D 25/50
---	----------------------------

B65D 47/08

having articulated or hinged closures {([B65D 55/16](#) takes precedence)}

References**Limiting references**

This place does not cover:

Hinged lids	B65D 43/16
Devices preventing loss of removable closure members	B65D 55/16

Special rules of classification

The use of available Indexing Codes is mandatory.

B65D 47/0814

{by at least three hinge sections, at least one having a length different from the others}

Definition statement

This place covers:

Illustrative example of subject matter classified in this group:

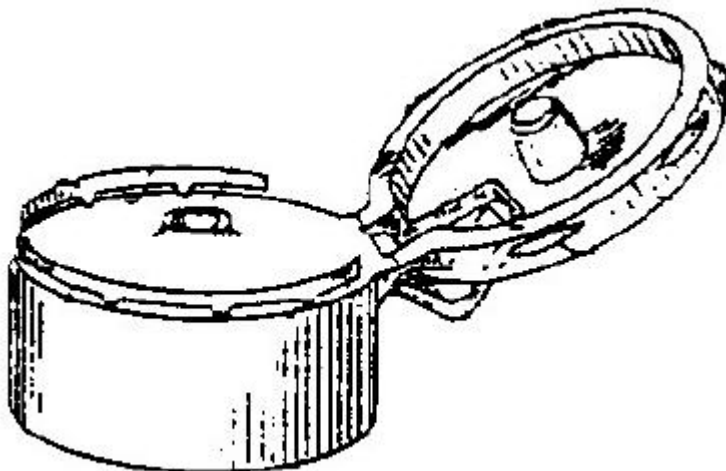
**Special rules of classification**

The use of available Indexing Codes is mandatory.

B65D 47/0819

{by cam action, e.g. interacting protrusions}

Definition statement

This place covers:

Illustrative example of subject matter classified in this group:

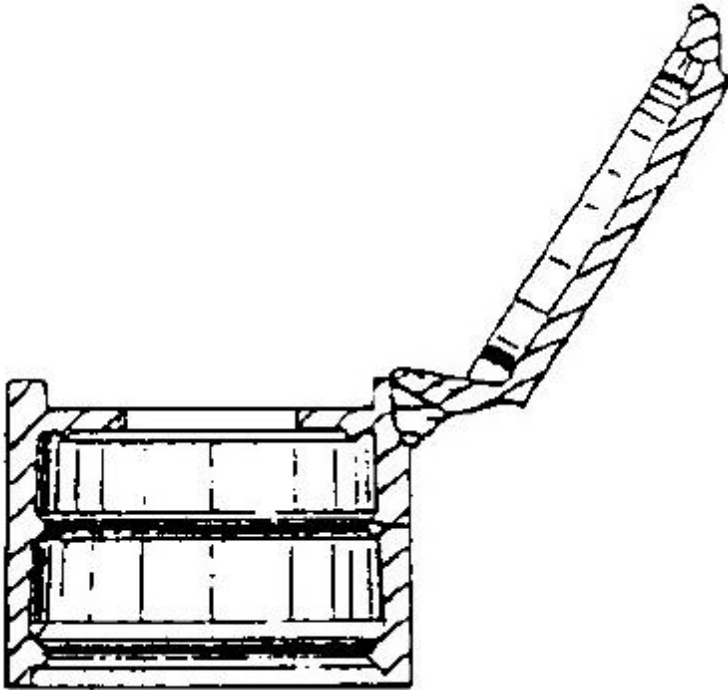

Special rules of classification

The use of available Indexing Codes is mandatory.

B65D 47/0823

{and elastically biased towards the closed position only}

Definition statement

This place covers:

Illustrative example of subject matter classified in this group:

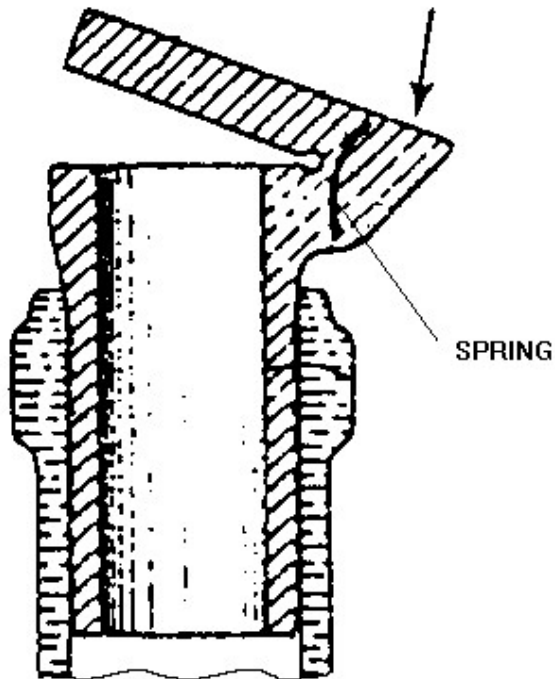

Special rules of classification

The use of available Indexing Codes is mandatory.

B65D 47/0828**{and elastically biased towards the open position}****Definition statement***This place covers:*

Illustrative example of subject matter classified in this group:

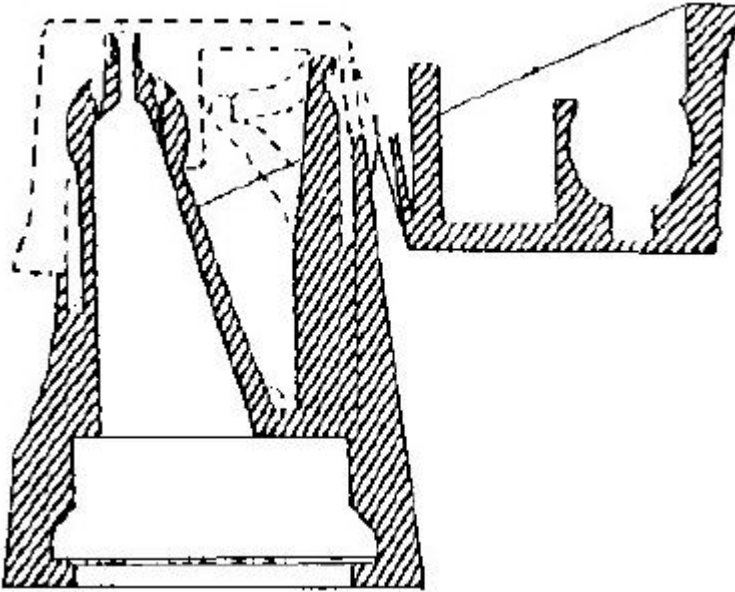
**Special rules of classification**

The use of available Indexing Codes is mandatory.

B65D 47/0838**{located at an edge of the base element}****Definition statement***This place covers:*

Illustrative example of subject matter classified in this group:

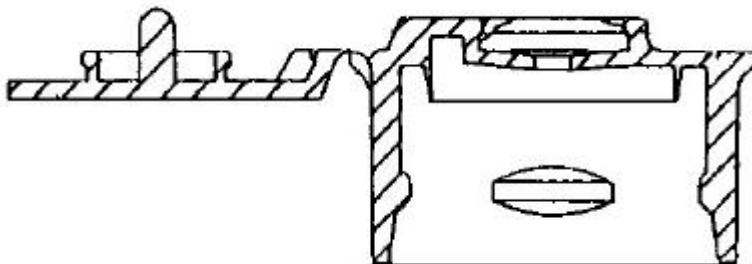

Special rules of classification

The use of available Indexing Codes is mandatory.

B65D 47/0842

{consisting of a strap of flexible material}

Definition statement

This place covers:

Illustrative example of subject matter classified in this group:

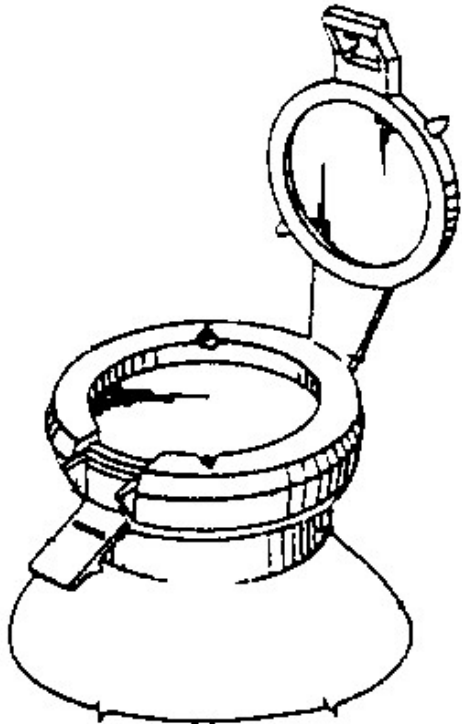
**References****Limiting references**

This place does not cover:

Straps with thinned hinged lines	B65D 47/0838 , B65D 47/0847
Cap formed separately from base but connected by strap	B65D 47/147 , B65D 47/148

Special rules of classification

The use of available Indexing Codes is mandatory.

B65D 47/0847

{located within a flat surface of the base element}

Definition statement

This place covers:

Illustrative example of subject matter classified in this group:

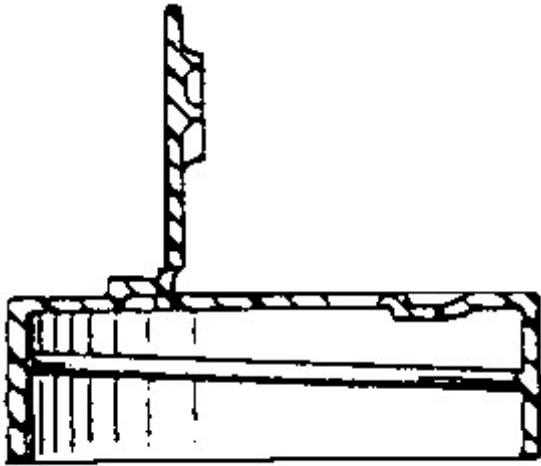
**References****Informative references**

Attention is drawn to the following places, which may be of interest for search:

Non-removable lids or covers hinged for upward or downward movement, comprising two or more cover sections hinged one to another	B65D 43/161
--	-----------------------------

Special rules of classification

The use of available Indexing Codes is mandatory.

B65D 47/0852**{consisting of a strap of flexible material}****Definition statement***This place covers:*

Illustrative example of subject matter classified in this group:

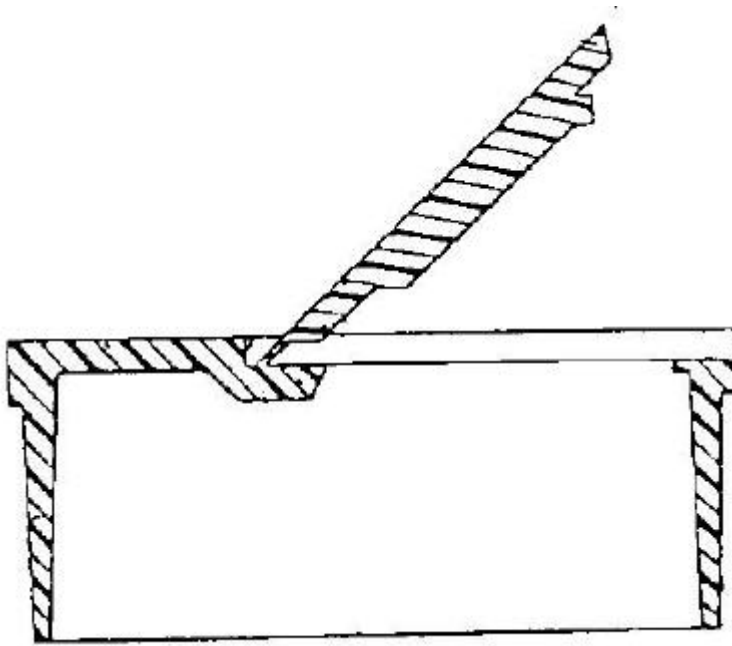
**References****Limiting references***This place does not cover:*

Straps with thinned hinged lines	B65D 47/0847
Cap formed separately from base but connected by strap	B65D 47/147 , B65D 47/148

Special rules of classification

The use of available Indexing Codes is mandatory.

B65D 47/0857

{made separately from the base element provided with the spout or discharge passage}

References**Limiting references**

This place does not cover:

Loosely-engaging lids or covers for jars, cans, or like containers for liquids without means for effecting sealing of container opening automatically when container is tilted for pouring	B65D 51/10
--	----------------------------

Special rules of classification

The use of available Indexing Codes is mandatory.

B65D 47/0861

{and elastically biased towards both the open and the closed positions}

Definition statement

This place covers:

Illustrative example of subject matter classified in this group:

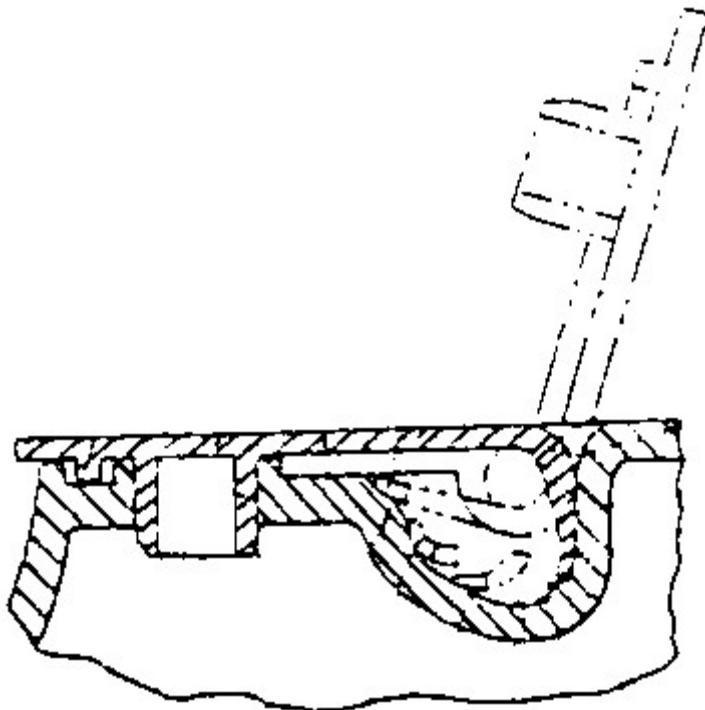
**Special rules of classification**

The use of available Indexing Codes is mandatory.

B65D 47/0866

{and elastically biased towards the closed position}

Definition statement

This place covers:

Illustrative example of subject matter classified in this group:

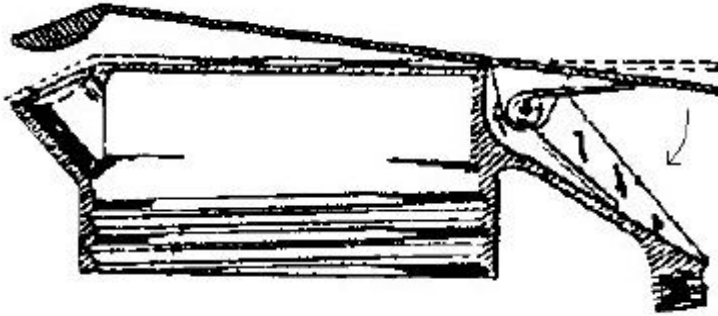
**Special rules of classification**

The use of available Indexing Codes is mandatory.

B65D 47/0871

{and elastically biased towards the open position}

Definition statement

This place covers:

Illustrative example of subject matter classified in this group:

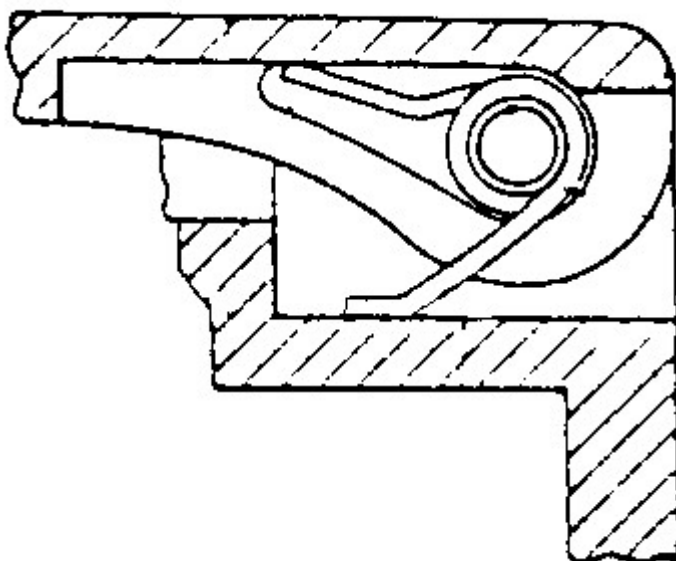
**Special rules of classification**

The use of available Indexing Codes is mandatory.

B65D 47/0876

{Hinges without elastic bias}

Special rules of classification

The use of available Indexing Codes is mandatory.

B65D 47/088

{located at an edge of the base element}

Definition statement

This place covers:

Illustrative example of subject matter classified in this group:

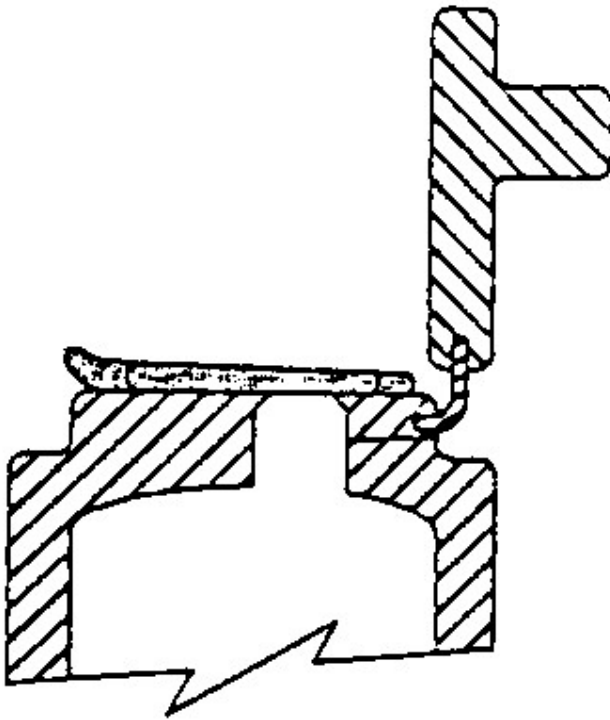

Special rules of classification

The use of available Indexing Codes is mandatory.

B65D 47/0885

{one part of the hinge being integral with the hinged closure and the other part with the base element, without any other additional hinge element}

Definition statement

This place covers:

Illustrative example of subject matter classified in this group:

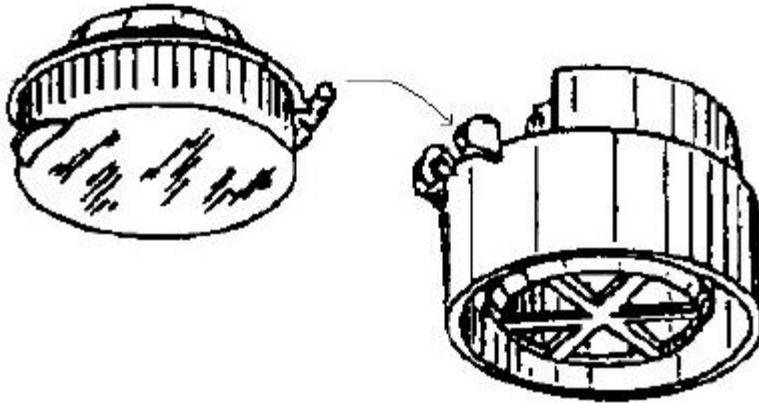

Special rules of classification

The use of available Indexing Codes is mandatory.

B65D 47/089

{located within a flat surface of the base element}

Definition statement

This place covers:

Illustrative example of subject matter classified in this group:

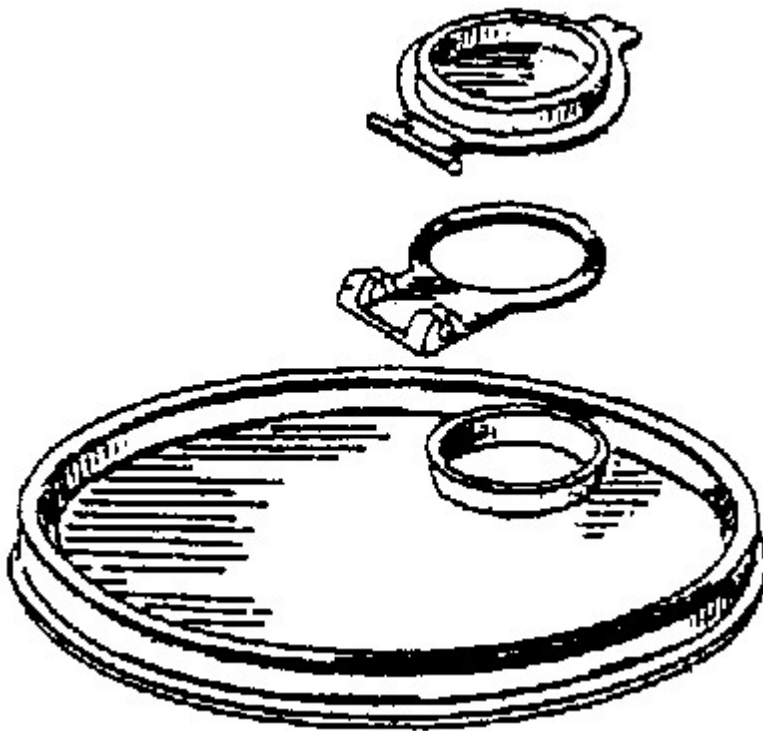
**Special rules of classification**

The use of available Indexing Codes is mandatory.

B65D 47/0895

{one part of the hinge being integral with the hinged closure and the other part with the base element, without any other additional hinge element}

Definition statement

This place covers:

Illustrative example of subject matter classified in this group:

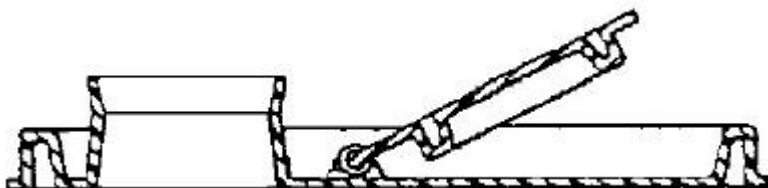
**Special rules of classification**

The use of available Indexing Codes is mandatory.

B65D 47/10**having frangible closures****Definition statement***This place covers:*

Illustrative example of subject matter classified in this group:

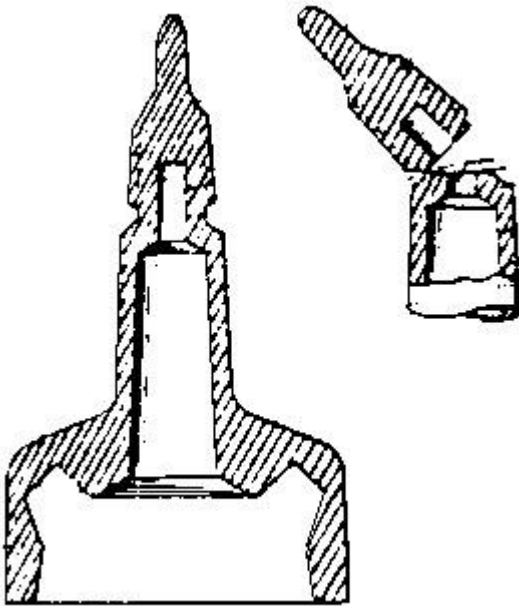
**References*****Informative references****Attention is drawn to the following places, which may be of interest for search:*

Opening arrangements or devices incorporated in or attached to, containers	B65D 17/401
Closures with frangible parts adapted to be pierced, torn, or removed, to provide discharge openings	B65D 47/36

B65D 47/103**{Membranes with a tearing element}****Definition statement***This place covers:*

Illustrative example of subject matter classified in this group:

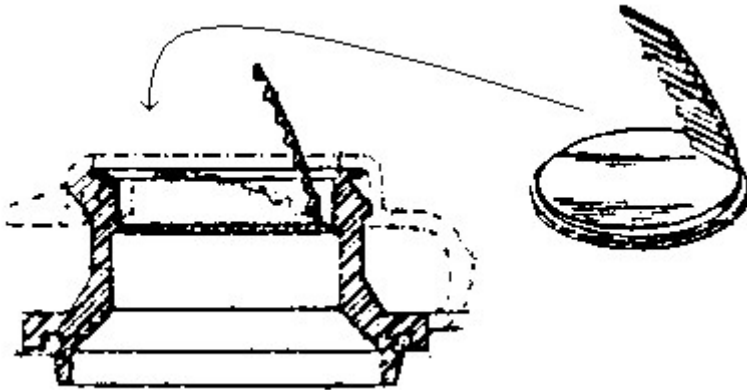
**References****Limiting references***This place does not cover:*

With devices for removing frangible parts	B65D 47/106
---	-----------------------------

Informative references*Attention is drawn to the following places, which may be of interest for search:*

Spouts formed separately from the container	B65D 5/746
---	----------------------------

B65D 47/106

{with devices for removing frangible parts of the pouring element or of its closure}

Definition statement

This place covers:

Illustrative example of subject matter classified in this group:

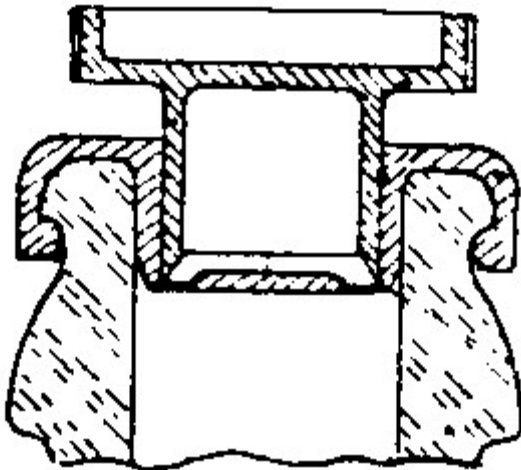
**References****Limiting references**

This place does not cover:

Membranes with a tearing element	B65D 47/103
----------------------------------	-----------------------------

Informative references

Attention is drawn to the following places, which may be of interest for search:

Caps, lids, or covers co-operating with an inner closure arranged to be opened by piercing, cutting, or tearing, having means for piercing, cutting, or tearing the inner closure	B65D 51/22
---	----------------------------

B65D 47/121

{Stoppers}

Definition statement

This place covers:

Illustrative example of subject matter classified in this group:

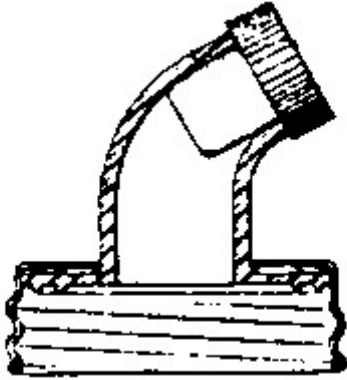

B65D 47/122

{Threaded caps}

Definition statement

This place covers:

Illustrative example of subject matter classified in this group:

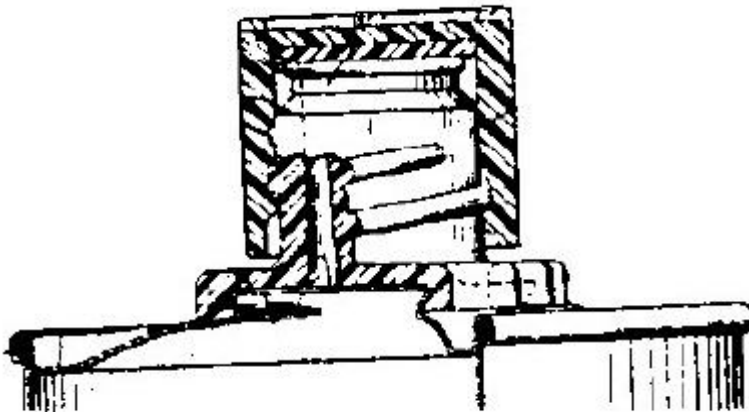

B65D 47/123

{with internal parts}

Definition statement

This place covers:

Illustrative example of subject matter classified in this group:

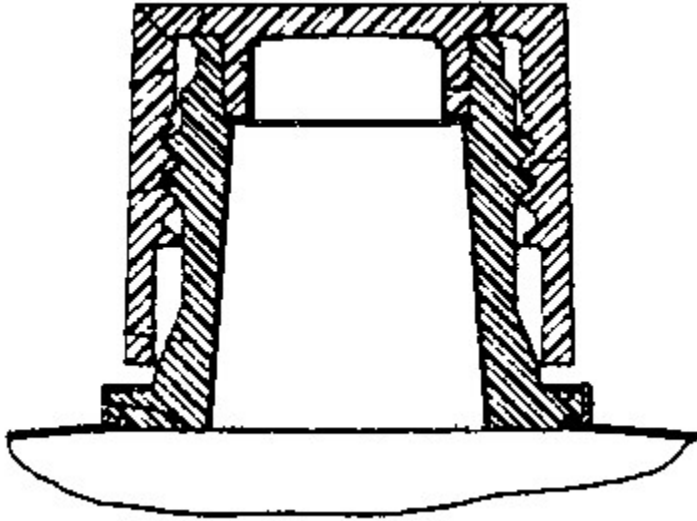

B65D 47/126

{with internal parts}

Definition statement

This place covers:

Illustrative example of subject matter classified in this group:

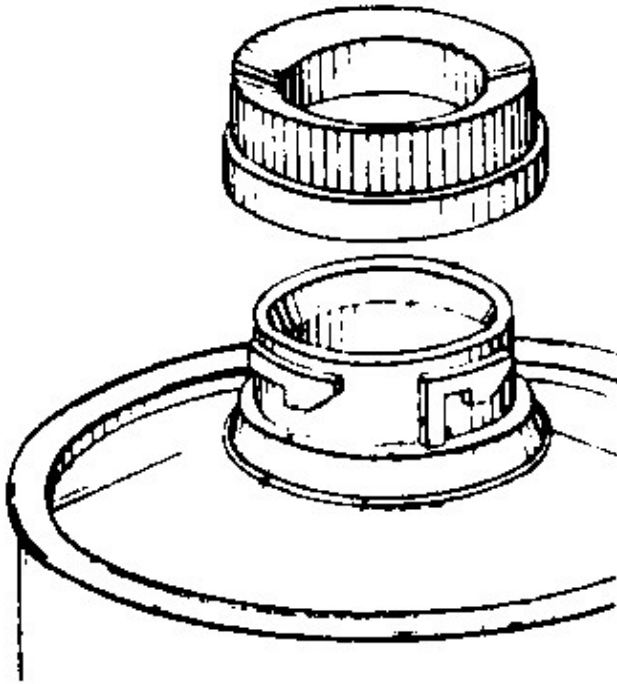

B65D 47/127

{Snap-on caps}

Definition statement

This place covers:

Illustrative example of subject matter classified in this group:

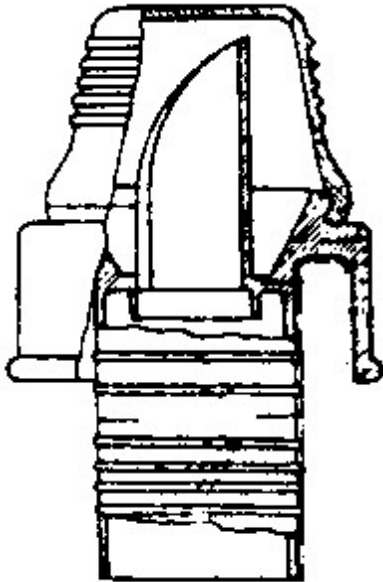

B65D 47/128

{with internal parts}

Definition statement

This place covers:

Illustrative example of subject matter classified in this group:

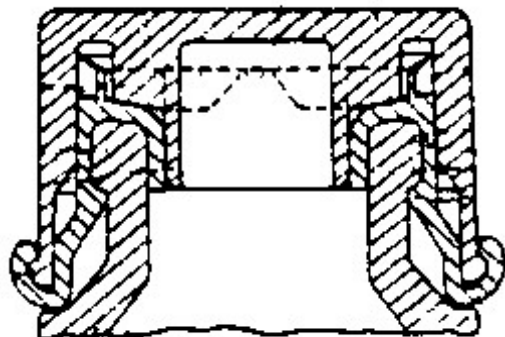

B65D 47/14**and closure-retaining means****References****Limiting references***This place does not cover:*

Pouring spouts or tubes; with discharge nozzles or passages having articulated or hinged closures	B65D 47/08
---	----------------------------

B65D 47/141**{for stoppers}****Definition statement***This place covers:*

Illustrative example of subject matter classified in this group:

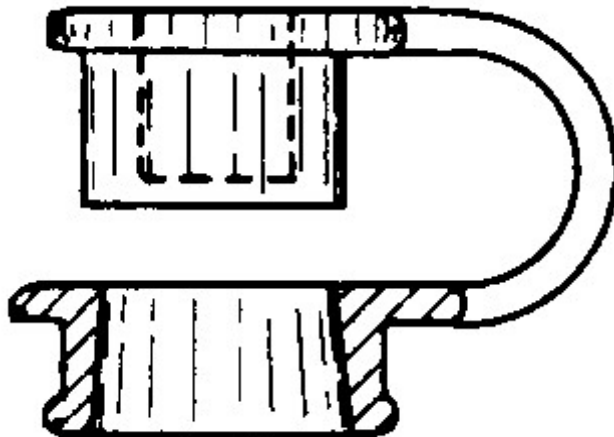
**References****Limiting references***This place does not cover:*

With pouring spouts or tubes; with discharge nozzles or passages having articulated or hinged closures	B65D 47/08
Devices preventing loss of removable closure members by an element constrained within the container neck	B65D 55/165

B65D 47/142**{for threaded caps}****Definition statement***This place covers:*

Illustrative example of subject matter classified in this group:

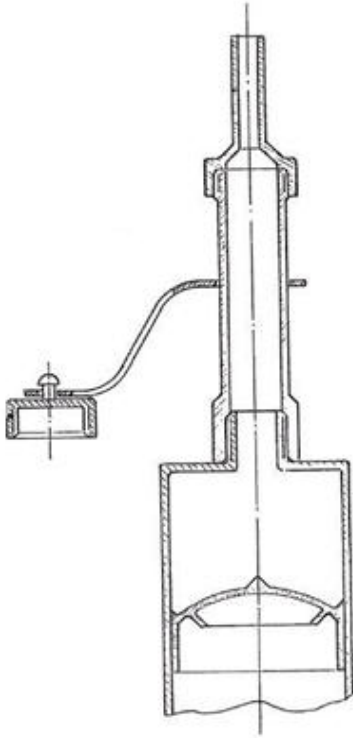
**References****Limiting references***This place does not cover:*

With pouring spouts or tubes; with discharge nozzles or passages having articulated or hinged closures	B65D 47/08
--	----------------------------

Informative references*Attention is drawn to the following places, which may be of interest for search:*

Devices preventing loss of removable closure members	B65D 55/16
--	----------------------------

B65D 47/143**{with internal parts}****References****Limiting references***This place does not cover:*

With pouring spouts or tubes; with discharge nozzles or passages having articulated or hinged closures	B65D 47/08
--	----------------------------

Informative references*Attention is drawn to the following places, which may be of interest for search:*

Devices preventing loss of removable closure members	B65D 55/16
--	----------------------------

B65D 47/145**{for caps with bayonet cams}****References****Limiting references***This place does not cover:*

With pouring spouts or tubes; with discharge nozzles or passages having articulated or hinged closures	B65D 47/08
--	----------------------------

Informative references*Attention is drawn to the following places, which may be of interest for search:*

Devices preventing loss of removable closure members	B65D 55/16
--	----------------------------

B65D 47/146**{with internal parts}****References****Limiting references***This place does not cover:*

With pouring spouts or tubes; with discharge nozzles or passages having articulated or hinged closures	B65D 47/08
--	----------------------------

Informative references*Attention is drawn to the following places, which may be of interest for search:*

Devices preventing loss of removable closure members	B65D 55/16
--	----------------------------

B65D 47/147**{for snap-on caps}****Definition statement***This place covers:*

Illustrative example of subject matter classified in this group:

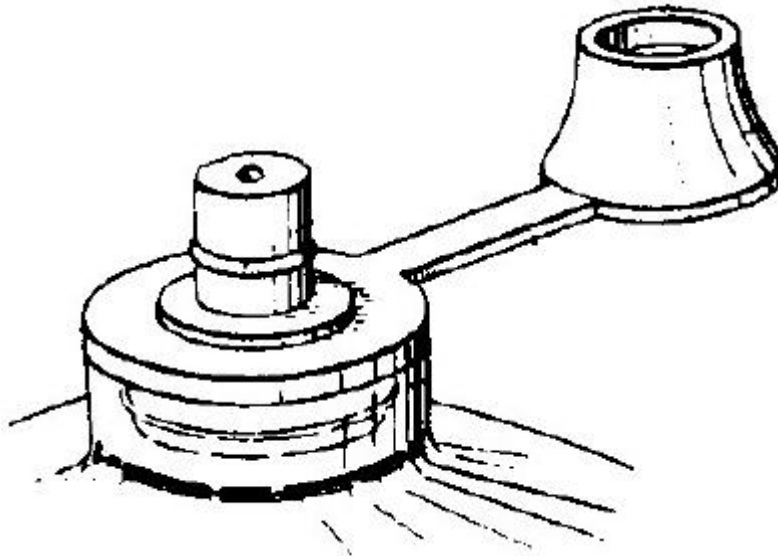
**References****Limiting references***This place does not cover:*

With pouring spouts or tubes; with discharge nozzles or passages having articulated or hinged closures	B65D 47/08
--	----------------------------

Informative references*Attention is drawn to the following places, which may be of interest for search:*

Devices preventing loss of removable closure members	B65D 55/16
--	----------------------------

Special rules of classificationcaps formed integrally with spout/base to be transferred to [B65D 47/0842](#) or [B65D 47/0852](#).

B65D 47/148**{with internal parts}****Definition statement***This place covers:*

Illustrative example of subject matter classified in this group:

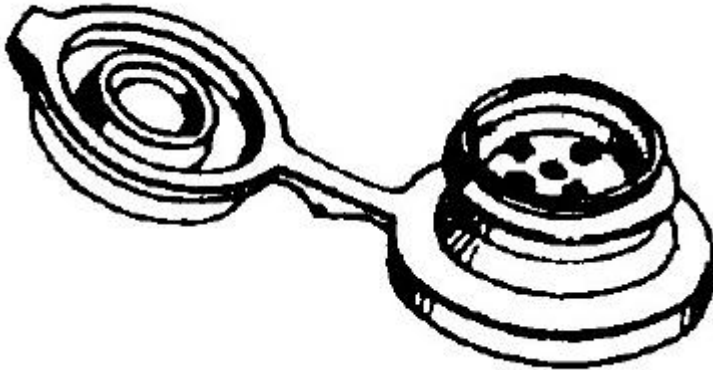
**References****Limiting references***This place does not cover:*

With pouring spouts or tubes; with discharge nozzles or passages having articulated or hinged closures	B65D 47/08
--	----------------------------

Informative references*Attention is drawn to the following places, which may be of interest for search:*

Devices preventing loss of removable closure members	B65D 55/16
--	----------------------------

Special rules of classificationcaps formed INTEGRALLY with spout/base to be transferred to [B65D 47/0842](#) or [B65D 47/0852](#).

B65D 47/16

with closures operating automatically when spout is immersed in discharged liquid

Definition statement

This place covers:

Illustrative example of subject matter classified in this group:

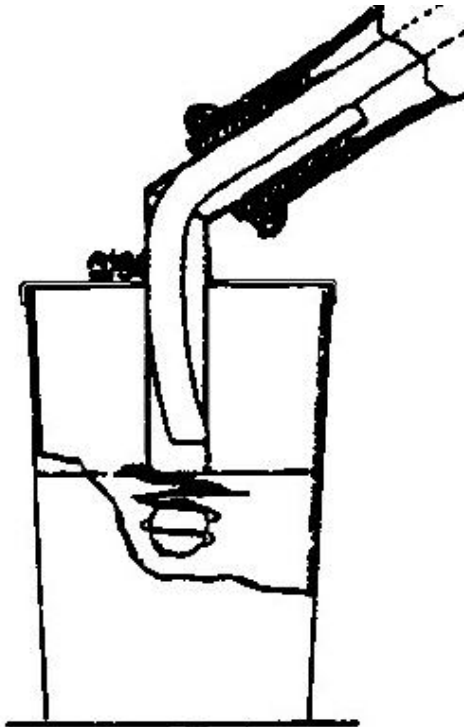

References

Informative references

Attention is drawn to the following places, which may be of interest for search:

Devices adding a disinfecting, deodorising, or cleaning agent to the water while flushing consisting of a separate container with an outlet through which the agent is introduced into the flushing water	E03D 9/03
---	---------------------------

B65D 47/18

for discharging drops; Droppers (droppers in general [B01L 3/00](#); {pipettes connected to container closures [B01L 3/0282](#)})

Definition statement

This place covers:

Illustrative example of subject matter classified in this group:

**References****Limiting references**

This place does not cover:

Eye-droppers	A61F 9/008
--------------	----------------------------

Informative references

Attention is drawn to the following places, which may be of interest for search:

Bottles or similar containers with necks or like restricted apertures, designed for pouring contents adapted to discharge drops	B65D 1/08
Droppers in general	B01L 3/00

B65D 47/185**{with sprinkling devices}****Definition statement***This place covers:*

Illustrative example of subject matter classified in this group:

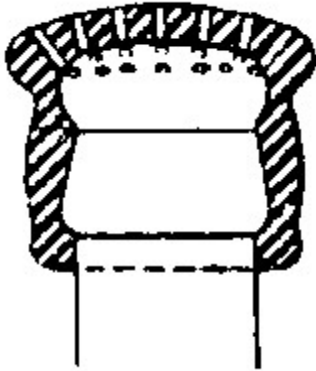
**B65D 47/2006****{formed by a rigid spout outlet opened by tilting of the spout outlet}****Definition statement***This place covers:*

Illustrative example of subject matter classified in this group:

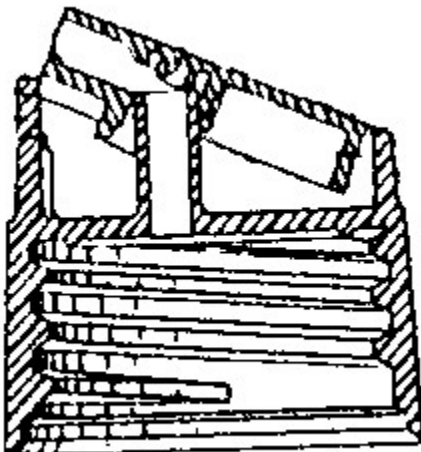
**References****Limiting references***This place does not cover:*

'Escargot' type spouts	B65D 47/305
------------------------	-----------------------------

Informative references

Attention is drawn to the following places, which may be of interest for search:

With pouring spouts or tubes, the spout being either flexible or having a flexible wall portion, whereby the spout is foldable between a dispensing and a non-dispensing position	B65D 47/066
---	-----------------------------

B65D 47/2012

{formed by a rigid spout outlet and an overcap, the spout outlet being either pushed into alignment with, or pushed through an opening in the overcap, upon rotation of the latter}

Definition statement

This place covers:

Illustrative example of subject matter classified in this group:

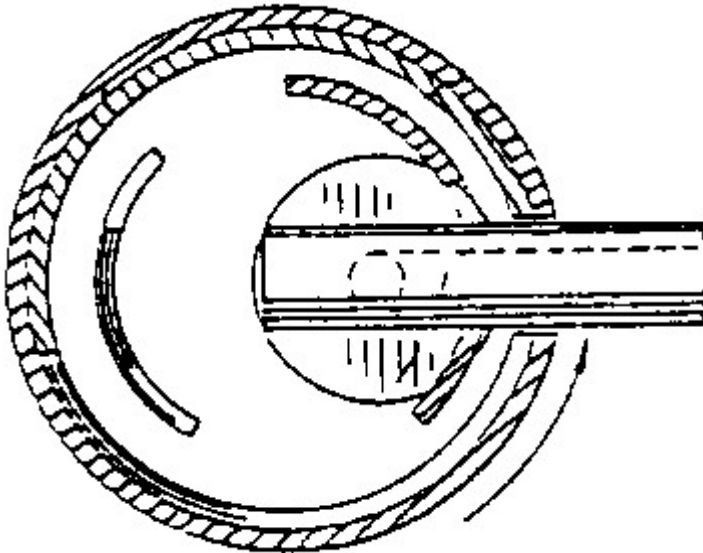
**References****Informative references**

Attention is drawn to the following places, which may be of interest for search:

A valve or like element which is opened or closed by deformation of the container or closure the separate element being formed by an overcap which constricts a spout, the spout being either pushed into alignment with, or pushed through, an opening in the overcap upon rotation of the latter	B65D 47/2043
--	------------------------------

B65D 47/2018

{comprising a valve or like element which is opened or closed by deformation of the container or closure}

References**Informative references**

Attention is drawn to the following places, which may be of interest for search:

With pouring spouts or tubes, with hinged, foldable or pivotable spouts	B65D 47/065
Flow being effected by deformation of container for liquid or other fluent material	B05B 11/04

B65D 47/2025

{Flexible bung-type elements}

Definition statement

This place covers:

Illustrative example of subject matter classified in this group:

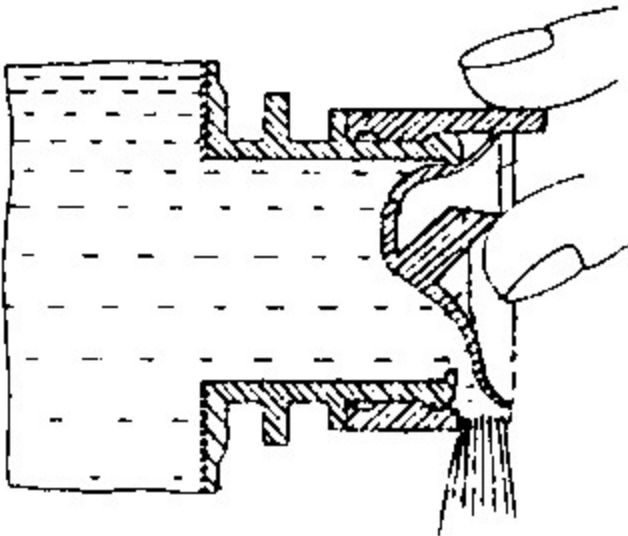
**References****Informative references**

Attention is drawn to the following places, which may be of interest for search:

Flexible containers disposed within polygonal containers formed by folding a carton blank combined with a valve, a tap or a piercer	B65D 77/067
Liquid-dispensing taps or cocks adapted to seal and open tapping holes of casks, operated by deforming a membrane-like closing element	B67D 3/042

B65D 47/2031

{the element being formed by a slit, narrow opening or constrictable spout, the size of the outlet passage being able to be varied by increasing or decreasing the pressure ([B65D 47/2025](#) takes precedence)}

Definition statement

This place covers:

Illustrative example of subject matter classified in this group:

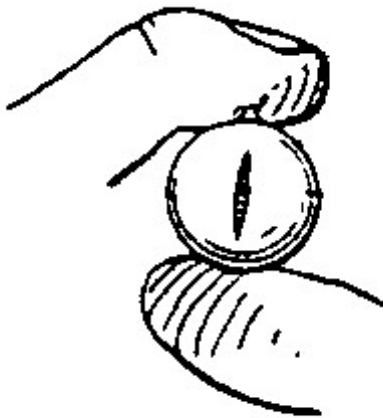
**References****Limiting references**

This place does not cover:

Flexible bung-type elements	B65D 47/2025
-----------------------------	------------------------------

Informative references

Attention is drawn to the following places, which may be of interest for search:

Venting occurs by automatic opening of the closure, container or other element the element being a valve, formed by a slit or narrow opening	B65D 51/165
--	-----------------------------

B65D 47/2037

{the element being opened or closed by actuating a separate element which causes the deformation, e.g. screw cap closing container slit}

Definition statement

This place covers:

Illustrative example of subject matter classified in this group:

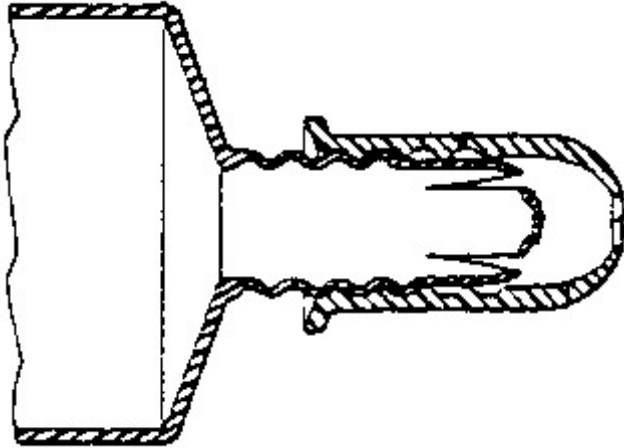

B65D 47/2043

{the separate element being formed by an overcap which constricts a spout, the spout being either pushed into alignment with, or pushed through, an opening in the overcap upon rotation of the latter}

Definition statement

This place covers:

Illustrative example of subject matter classified in this group:

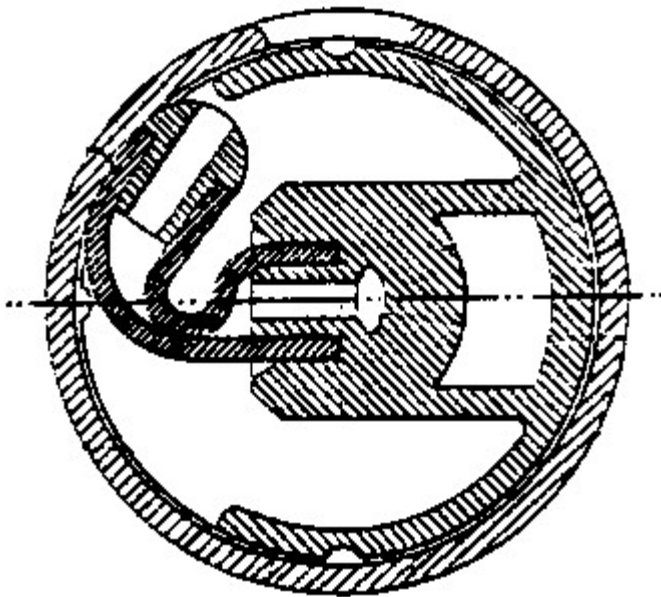
**References*****Informative references***

Attention is drawn to the following places, which may be of interest for search:

Hand-operated members for controlling discharge formed by a rigid spout outlet and an overcap, the spout outlet being either pushed into alignment with, or pushed through an opening in the overcap, upon rotation of the latter	B65D 47/2012
---	------------------------------

B65D 47/205

{the valve being formed by a tubular flexible sleeve surrounding a rod-like element provided with at least one radial passageway which is normally closed by the sleeve}

Definition statement

This place covers:

Illustrative example of subject matter classified in this group:

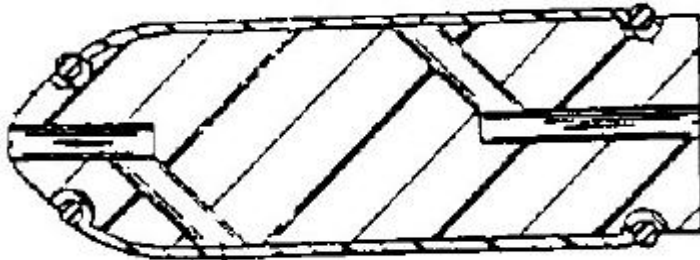
**References****Informative references**

Attention is drawn to the following places, which may be of interest for search:

Flexible check valves, the closure elements being fixed along all or a part of their periphery	F16K 15/144
--	-----------------------------

B65D 47/2056

{lift valve type (lift valves not opened by deformation [B65D 47/24](#))}

References**Informative references**

Attention is drawn to the following places, which may be of interest for search:

Venting occurs by automatic opening of the closure, container or other element the element being a valve	B65D 51/1644
Outlet valves actuated by the pressure of the fluid to be sprayed	B05B 11/0062

B65D 47/2062

{in which the deformation raises or lowers the valve stem}

Definition statement

This place covers:

Illustrative example of subject matter classified in this group:

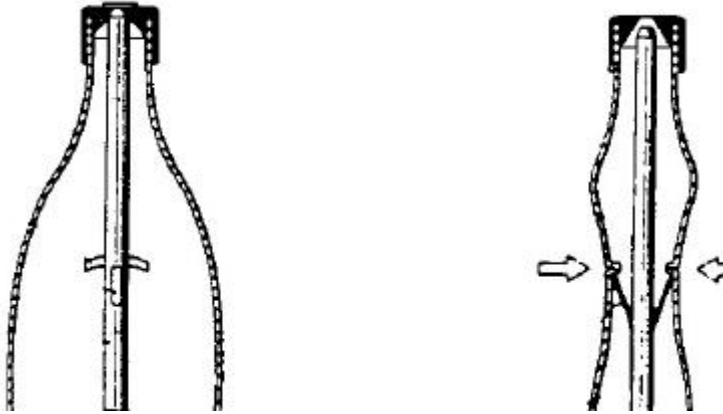
**References****Informative references**

Attention is drawn to the following places, which may be of interest for search:

Arrangements for feeding the ink to the nibs by valves automatically closing	B43K 5/1836
--	-----------------------------

B65D 47/2068

{in which the stem is lowered by the pressure of the contents and thereby opening the valve}

Definition statement

This place covers:

Illustrative example of subject matter classified in this group:

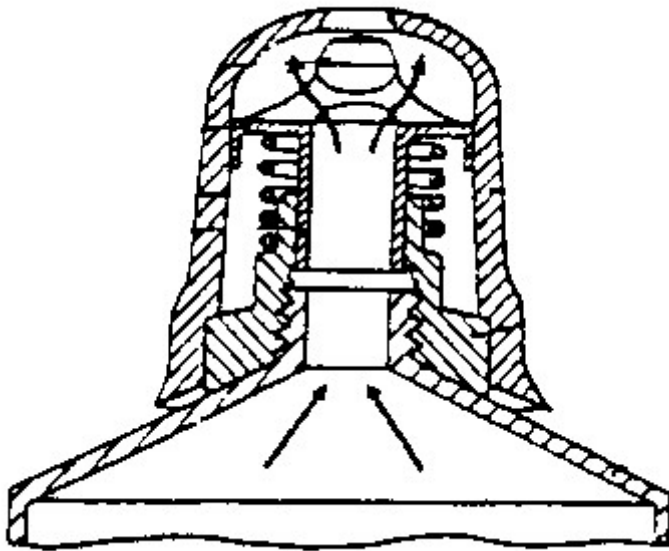

References

Informative references

Attention is drawn to the following places, which may be of interest for search:

With poppet valves being opened or closed by imparting a motion to the valve stem	B65D 47/248
---	-----------------------------

B65D 47/2075

{in which the stem is raised by the pressure of the contents and thereby opening the valve}

Definition statement

This place covers:

Illustrative example of subject matter classified in this group:

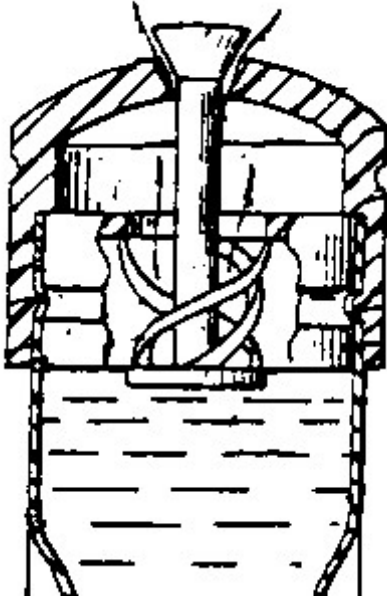
**References****Limiting references**

This place does not cover:

Annular rings	B65D 47/2093
---------------	------------------------------

Informative references

Attention is drawn to the following places, which may be of interest for search:

Slide valve type	B65D 47/2093
------------------	------------------------------

B65D 47/2081

{in which the deformation raises or lowers the valve port}

Definition statement

This place covers:

Illustrative example of subject matter classified in this group:

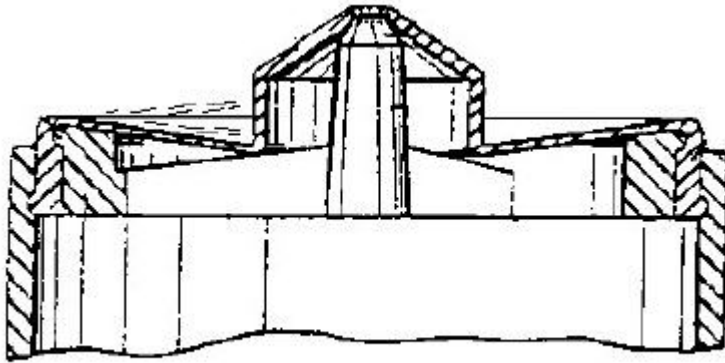
**References****Limiting references**

This place does not cover:

Discs	B65D 47/2075
-------	------------------------------

Informative references

Attention is drawn to the following places, which may be of interest for search:

Annular rings	B65D 47/2093
---------------	------------------------------

B65D 47/2087

{the port being formed by a slidable rigid cap-like element which is moved linearly by the pressure of the contents}

Definition statement

This place covers:

Illustrative example of subject matter classified in this group:

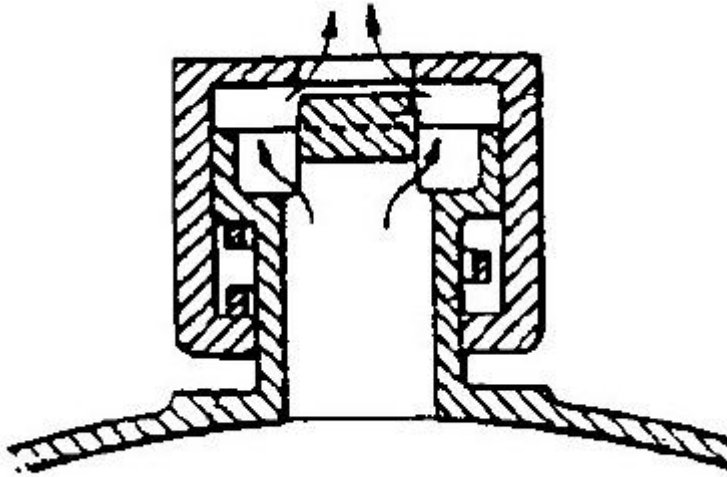
**References****Informative references**

Attention is drawn to the following places, which may be of interest for search:

Poppet valve being opened or closed by actuating a cap-like element moving linearly	B65D 47/243
---	-----------------------------

B65D 47/2093

{slide valve type (slide valves not opened by deformation [B65D 47/26](#))}

Definition statement

This place covers:

Illustrative example of subject matter classified in this group:

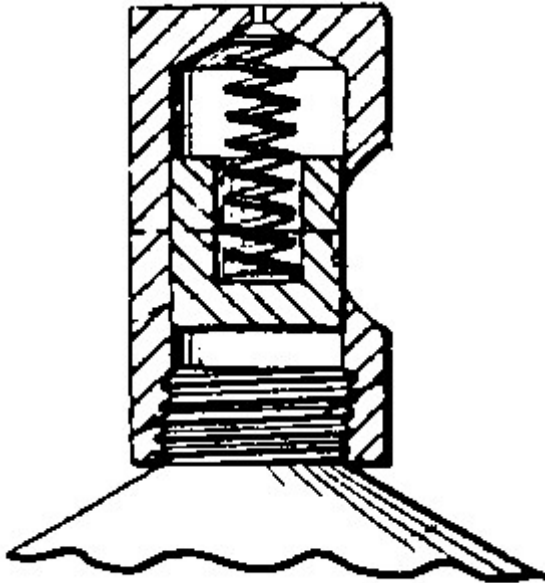
**References****Informative references**

Attention is drawn to the following places, which may be of interest for search:

Hand-operated members for controlling discharge comprising a lift valve type	B65D 47/2056
With means for venting air or gas whereby venting occurs by automatic opening of the closure, container or other element, the element being a valve	B65D 51/1644
Flow being effected by deformation of container for liquid or other fluent material	B05B 11/04

B65D 47/24

with poppet valves {or lift valves, i.e. valves opening or closing a passageway by a relative motion substantially perpendicular to the plane of the seat}

References**Limiting references**

This place does not cover:

Opened by deformation	B65D 47/2056
-----------------------	------------------------------

Informative references

Attention is drawn to the following places, which may be of interest for search:

Arrangements for feeding the ink to the nibs by valves automatically closing	B43K 5/1836
--	-----------------------------

B65D 47/242

{moving helically}

Definition statement

This place covers:

Illustrative example of subject matter classified in this group:

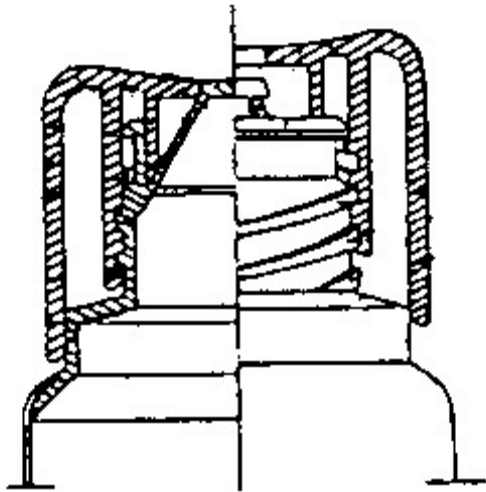
**References****Informative references**

Attention is drawn to the following places, which may be of interest for search:

The valve being opened or closed by actuating a stopper-type element moving helically	B65D 47/246
---	-----------------------------

B65D 47/243

{moving linearly, i.e. without rotational motion}

Definition statement

This place covers:

Illustrative example of subject matter classified in this group:

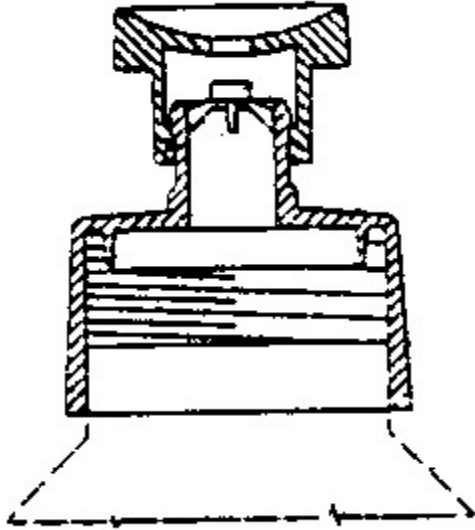
**References****Informative references**

Attention is drawn to the following places, which may be of interest for search:

The valve being opened or closed by actuating a stopper-type element moving linearly	B65D 47/247
--	-----------------------------

B65D 47/244

{being rotated without axial translation, whilst transmitting axial motion to an internal valve stem or valve seat}

Definition statement

This place covers:

Illustrative example of subject matter classified in this group:

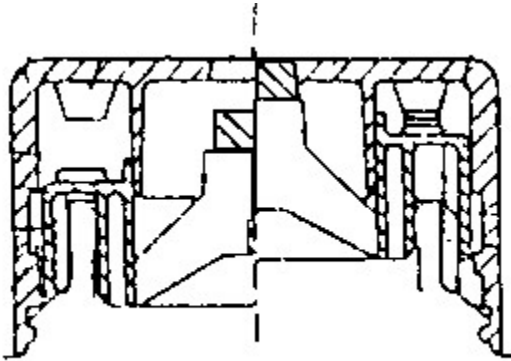

B65D 47/246

{moving helically, e.g. screw tap}

Definition statement

This place covers:

Illustrative example of subject matter classified in this group:

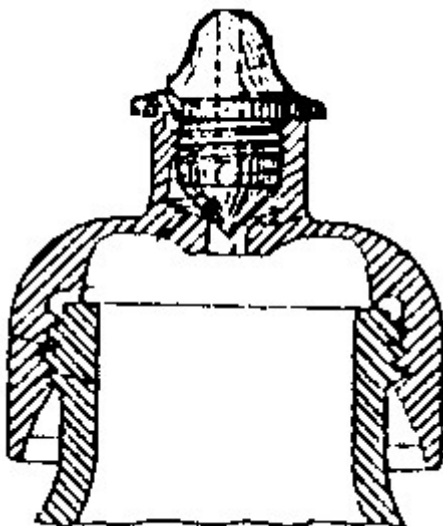

References

Informative references

Attention is drawn to the following places, which may be of interest for search:

The valve being opened or closed by actuating a cap-like element moving helically	B65D 47/242
---	-----------------------------

B65D 47/247

{moving linearly, i.e. without rotational motion}

Definition statement

This place covers:

Illustrative example of subject matter classified in this group:

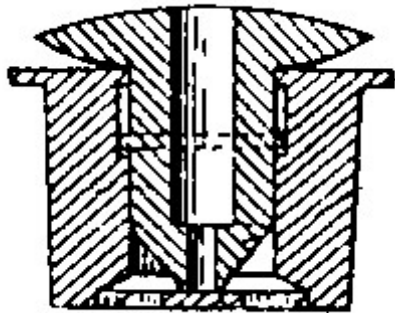

References

Informative references

Attention is drawn to the following places, which may be of interest for search:

The valve being opened or closed by actuating a cap-like element moving linearly	B65D 47/243
--	-----------------------------

B65D 47/248

{the valve being opened or closed by imparting a motion to the valve stem
([B65D 47/244](#), [B65D 47/245](#) take precedence)}

Definition statement

This place covers:

Illustrative example of subject matter classified in this group:

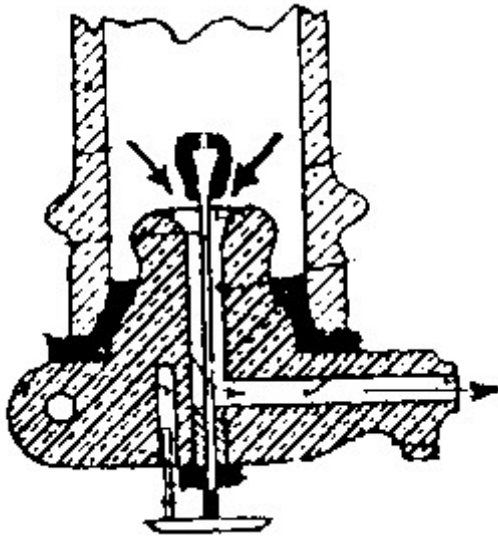
**References****Limiting references**

This place does not cover:

The valve being opened or closed by actuating a cap-like element being rotated without axial translation, whilst transmitting axial motion to an internal valve stem or valve seat	B65D 47/244
With poppet valves the valve being opened or closed by actuating a stopper-type element	B65D 47/245
For valve construction	B65D 47/249 , B67D
Valves opening upon tilting the container	B65D 51/10

Informative references

Attention is drawn to the following places, which may be of interest for search:

Lift valve type in which the deformation raises or lowers the valve stem in which the stem is lowered by the pressure of the contents and thereby opening the valve	B65D 47/2068
Arrangements for feeding the ink to the nibs by valves automatically closing	B43K 5/1836

B65D 47/249**{by means of a lever mechanism}****Definition statement***This place covers:*

Illustrative example of subject matter classified in this group:

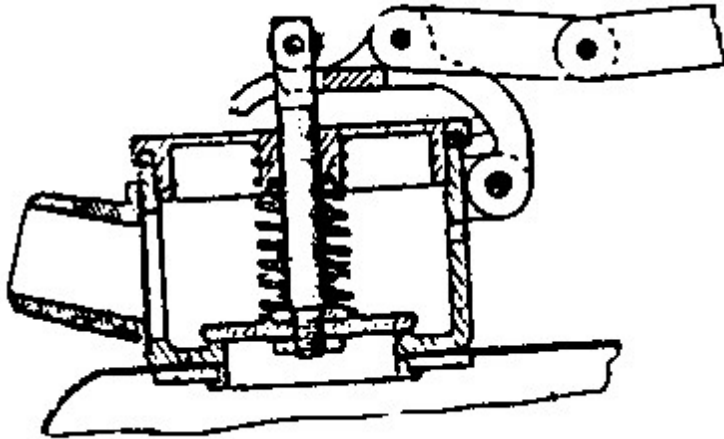
**B65D 47/26****with slide valves {, i.e. valves that open and close a passageway by sliding over a port}, e.g. formed with slidable spouts****References****Limiting references***This place does not cover:*

Opened by deformation	B65D 47/2093
-----------------------	------------------------------

B65D 47/261**{having a rotational or helicoidal movement ([B65D 47/30](#) takes precedence)}****References****Limiting references***This place does not cover:*

Hand-operated members for controlling discharge with plug valves	B65D 47/30
'escargot' type valve	B65D 47/305

B65D 47/263**{between tubular parts}****Definition statement***This place covers:*

Illustrative example of subject matter classified in this group:

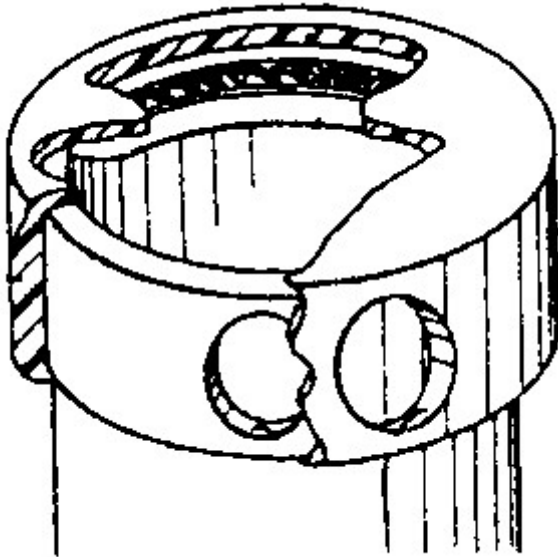
**References****Limiting references***This place does not cover:*

Hand-operated members for controlling discharge formed by a rigid spout outlet and an overcap, the spout outlet being either pushed into alignment with, or pushed through an opening in the overcap, upon rotation of the latter	B65D 47/2012
---	------------------------------

B65D 47/265

{between planar parts ([B65D 47/24](#) takes precedence)}

Definition statement

This place covers:

Illustrative example of subject matter classified in this group:

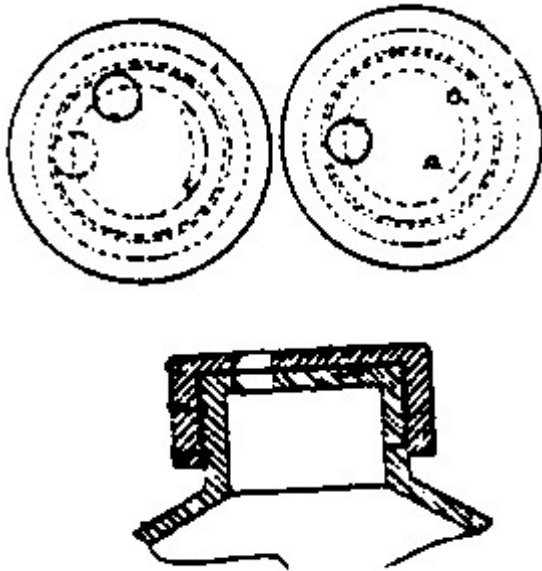
**References****Limiting references**

This place does not cover:

Hand-operated members for controlling discharge with poppet valves	B65D 47/24
--	----------------------------

B65D 47/266

{the rotational movement being transmitted by displacement of an additional external element, e.g. overcap ([B65D 47/265](#) takes precedence)}

Definition statement

This place covers:

Illustrative example of subject matter classified in this group:

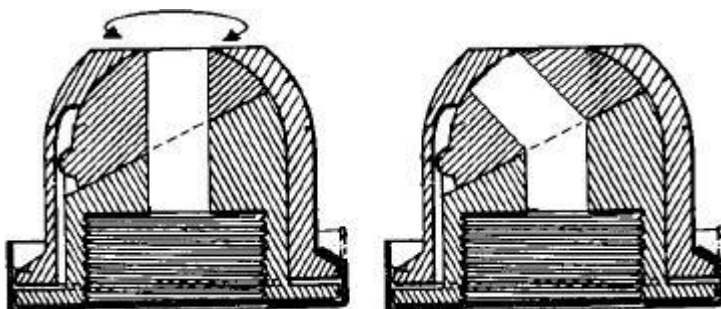

References

Limiting references

This place does not cover:

Slide valves having a rotational or helicoidal movement between planar parts	B65D 47/265
--	-----------------------------

B65D 47/268

{the valve member pivoting about an axis perpendicular to the container mouth axis ([B65D 47/266](#) takes precedence)}

Definition statement

This place covers:

Illustrative example of subject matter classified in this group:

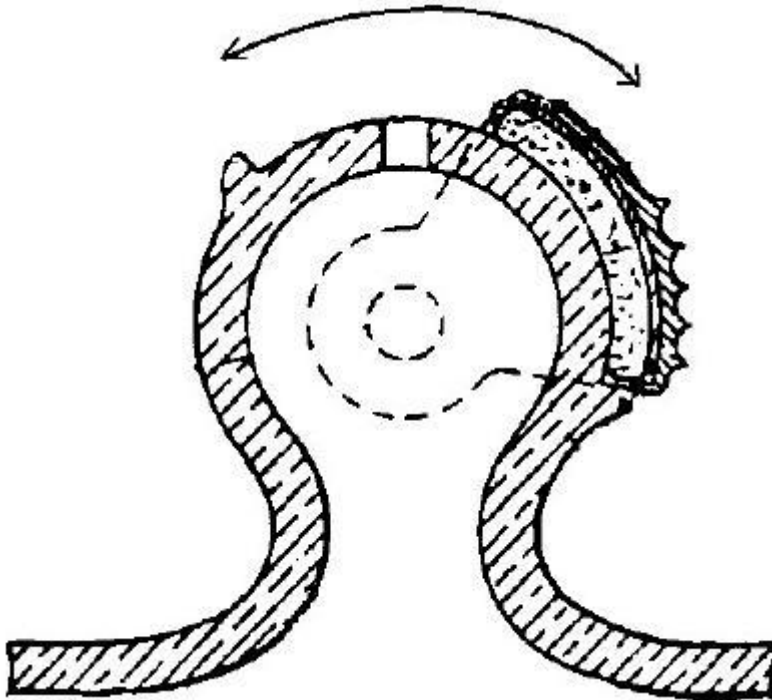

References

Limiting references

This place does not cover:

With slide valves having a rotational or helicoidal movement, the rotational movement being transmitted by displacement of an additional external element	B65D 47/266
---	-----------------------------

B65D 47/28

having linear movement

References**Limiting references***This place does not cover:*

Opened by deformation	B65D 47/2093
-----------------------	------------------------------

B65D 47/283

{between tubular parts}

Definition statement*This place covers:*

Illustrative example of subject matter classified in this group:

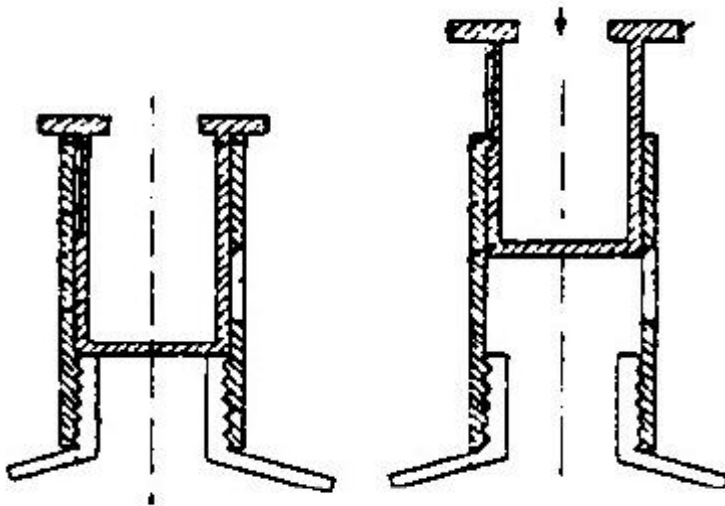

B65D 47/286

{between planar parts}

Definition statement

This place covers:

Illustrative example of subject matter classified in this group:

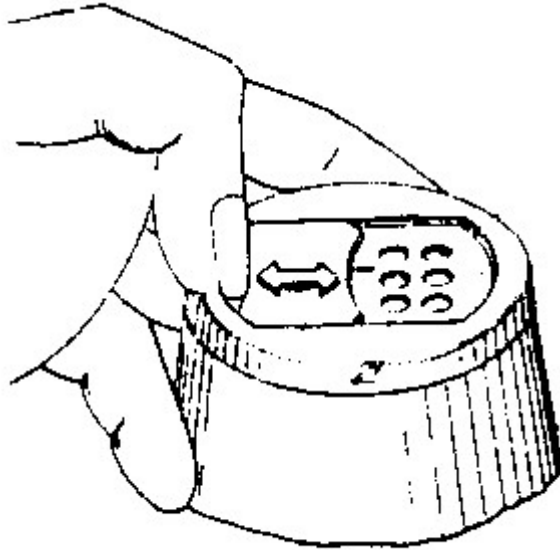

B65D 47/30

with plug valves {, i.e. valves that open and close a passageway by turning a cylindrical or conical plug without axial passageways}

Definition statement

This place covers:

Illustrative example of subject matter classified in this group:

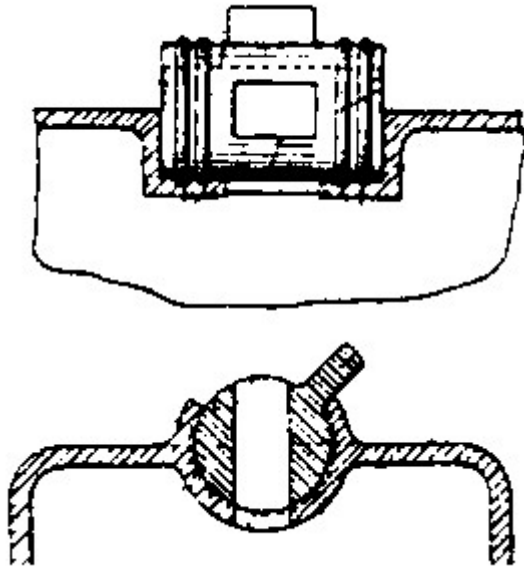

B65D 47/305

{provided with a spout, e.g. "escargot"-type valve}

Definition statement

This place covers:

Illustrative example of subject matter classified in this group:

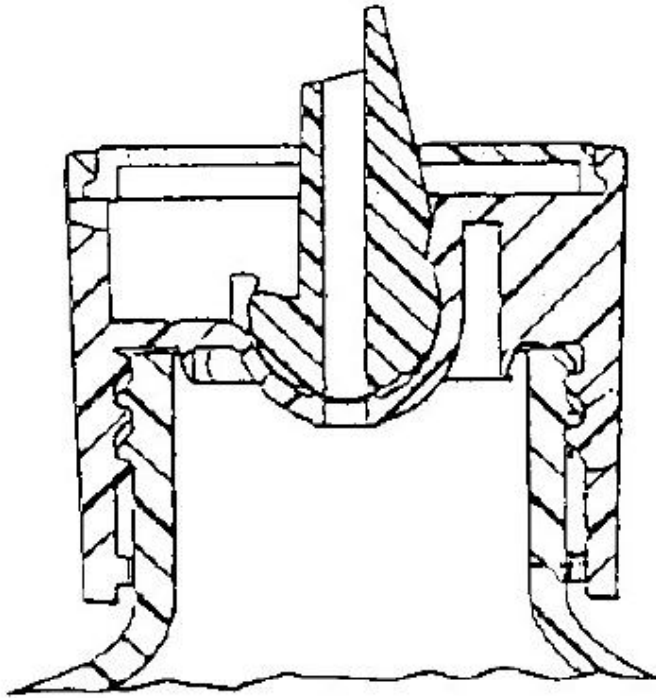

References

Informative references

Attention is drawn to the following places, which may be of interest for search:

Hand-operated members for controlling discharge formed by a rigid spout outlet opened by tilting of the spout outlet	B65D 47/2006
--	------------------------------

B65D 47/32**with means for venting****Definition statement***This place covers:*

Illustrative example of subject matter classified in this group:

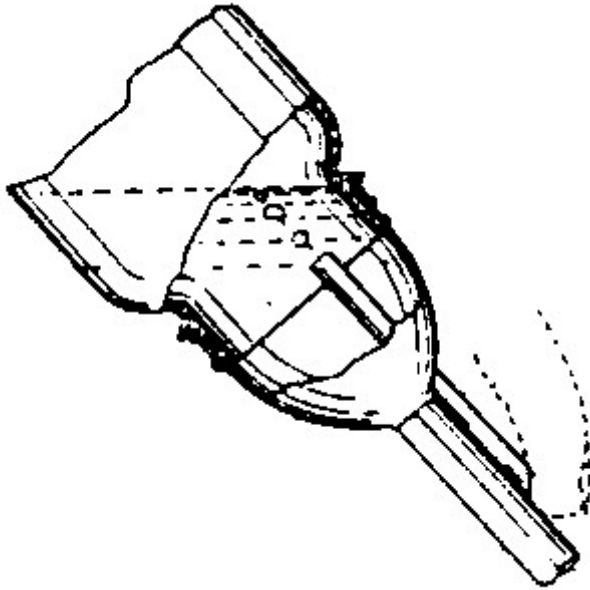
**References****Limiting references***This place does not cover:*

Spouts with air-inlet	B65D 25/40
For discharging drops	B65D 47/18
Air-inlet valves opening during dispensing	B65D 51/1644 , B65D 51/165

Informative references*Attention is drawn to the following places, which may be of interest for search:*

Venting means	B65D 2205/00
---------------	------------------------------

B65D 47/36

Closures with frangible parts adapted to be pierced, torn, or removed, to provide discharge openings ([B65D 51/18](#) takes precedence; caps with piercable membranes [B65D 41/20](#), [B65D 41/50](#))

Definition statement

This place covers:

Illustrative example of subject matter classified in this group:

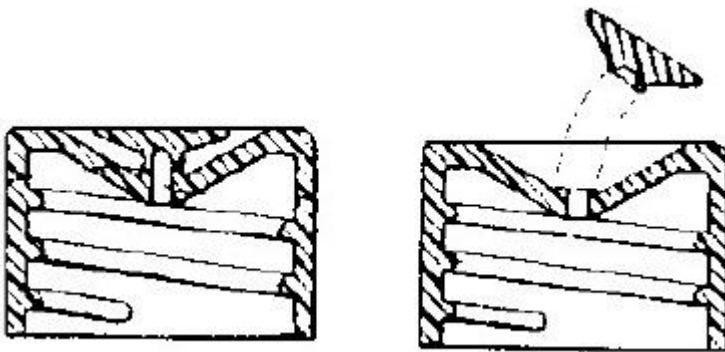

References

Limiting references

This place does not cover:

Arrangements of closures with protective outer cap-like covers or of two or more co-operating closures	B65D 51/18
--	----------------------------

Informative references

Attention is drawn to the following places, which may be of interest for search:

With pouring spouts or tubes, with discharge nozzles or passages having frangible closures	B65D 47/10
--	----------------------------

B65D 47/38

with piercing means arranged to act subsequently as a valve to control the opening

Definition statement

This place covers:

Illustrative example of subject matter classified in this group:

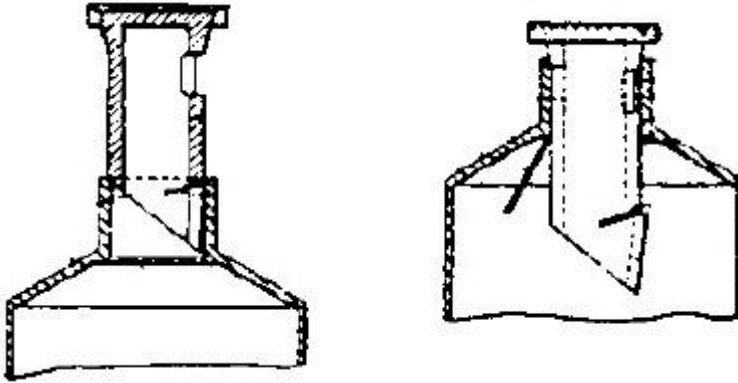
**B65D 47/40**

with drip catchers or drip-preventing means

Definition statement

This place covers:

Illustrative example of subject matter classified in this group:

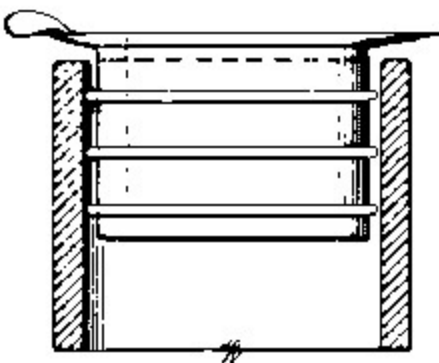
**References****Limiting references**

This place does not cover:

For discharging drops	B65D 47/18
-----------------------	----------------------------

Informative references

Attention is drawn to the following places, which may be of interest for search:

Integral drip catchers or drip-preventing means	B65D 23/06
---	----------------------------

B65D 47/42

with pads or like contents-applying means ({contents-applying means associated to aerosol container nozzles [B65D 83/285](#); } brushes combined or associated with containers [A46B 11/00](#); swabs for applying media to the human body from an integral supply [A61F13/40](#))

Definition statement

This place covers:

Illustrative example of subject matter classified in this group:

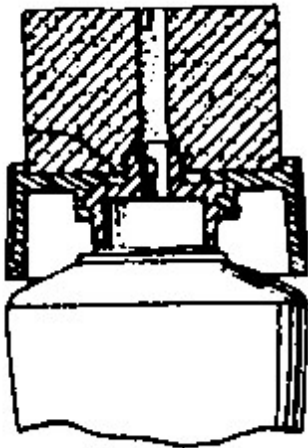
**References****Limiting references**

This place does not cover:

Containers specially adapted for applying liquid using a roller or a ball	A45D 34/041 , A45D 34/042
Hand implements for shoe-cleaning with applicators for shoe polish	A47L 23/05

Application-oriented references

Examples of places where the subject matter of this place is covered when specially adapted, used for a particular purpose, or incorporated in a larger system:

Swabs for applying media to the human body from an integral supply	A61F13/40
--	---------------------------

Informative references

Attention is drawn to the following places, which may be of interest for search:

With auxiliary devices for applying contents to surfaces	B65D 35/36
--	----------------------------

B65D 47/44

combined with slits opening when container is deformed or when pad is pressed against surface to which contents are to be applied (pliable tubular containers with valves opening when closure is pressed against surfaces {[B65D 47/2018](#)})

Definition statement

This place covers:

Illustrative example of subject matter classified in this group:

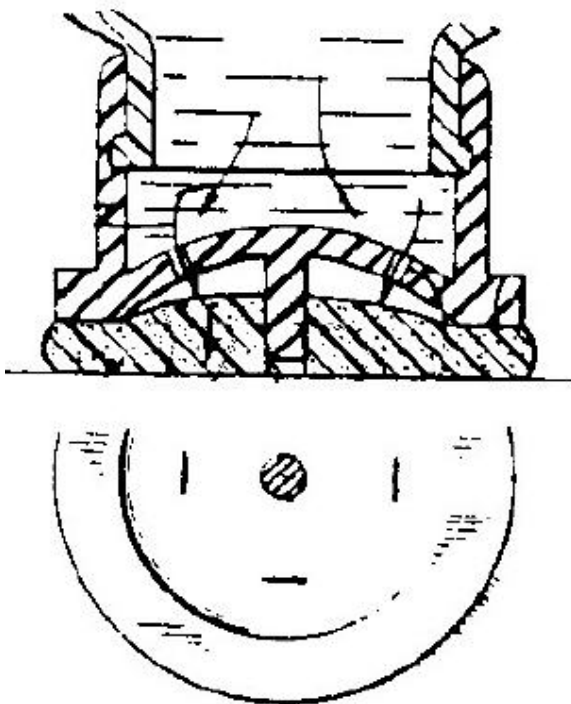
**References****Limiting references**

This place does not cover:

A valve or like element which is opened or closed by deformation of the container or closure	B65D 47/2018
--	------------------------------

Application-oriented references

Examples of places where the subject matter of this place is covered when specially adapted, used for a particular purpose, or incorporated in a larger system:

For cleaning or polishing shoes	A47L 23/04
---------------------------------	----------------------------

B65D 49/00

Arrangements or devices for preventing refilling of containers (integral, or permanently secured, closures for containers specially adapted to be opened by cutting, piercing, or tearing of wall portions [B65D 17/00](#); for initial filling and for preventing subsequent refilling [B65D 47/02](#))

References

Informative references

Attention is drawn to the following places, which may be of interest for search:

Integral, or permanently secured, closures for containers specially adapted to be opened by cutting, piercing, or tearing of wall portions	B65D 17/00
--	----------------------------

B65D 49/04

Weighted valves

Definition statement

This place covers:

Illustrative example of subject matter classified in this group:

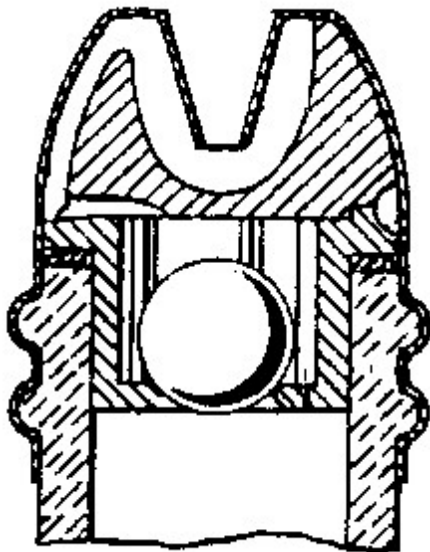

B65D 49/06

with additional loading weights

Definition statement

This place covers:

Illustrative example of subject matter classified in this group:

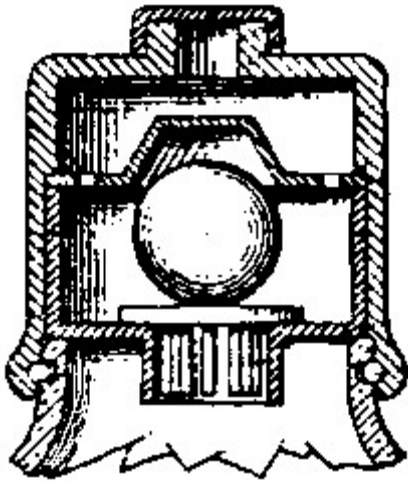

B65D 49/08

Spring-loaded valves

Definition statement

This place covers:

Illustrative example of subject matter classified in this group:

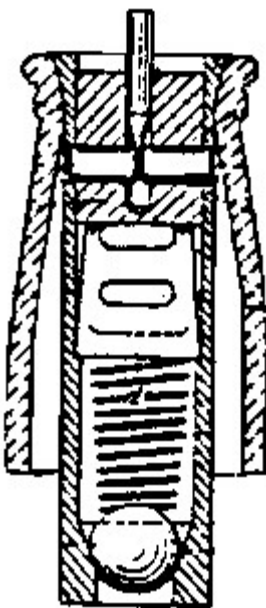

B65D 49/10

Arrangements of several valves

Definition statement

This place covers:

Illustrative example of subject matter classified in this group:

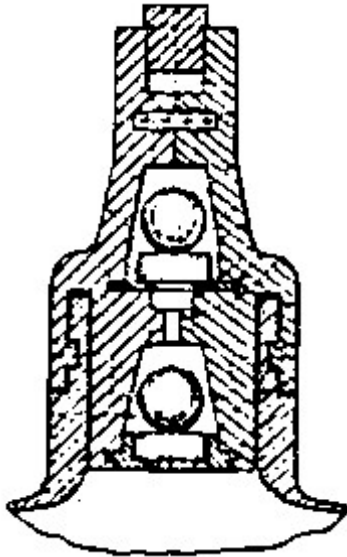

B65D 49/12

by destroying, in the act of opening the container, an integral portion thereof

Definition statement

This place covers:

Illustrative example of subject matter classified in this group:

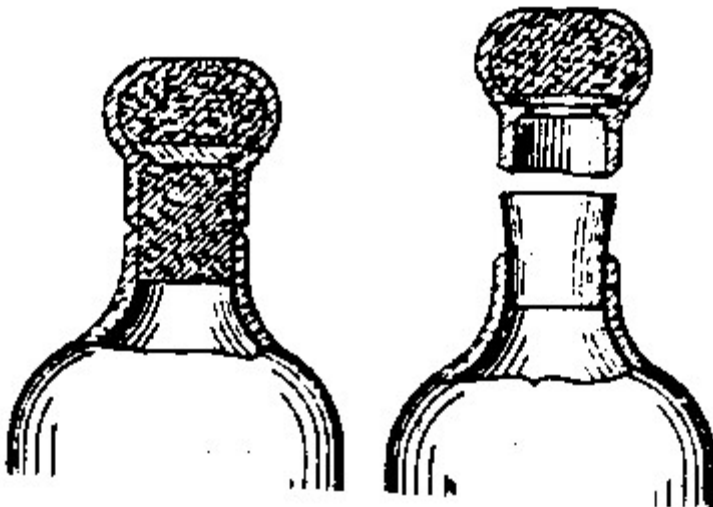

References

Informative references

Attention is drawn to the following places, which may be of interest for search:

Integral frangible closures	B65D 1/0238
-----------------------------	-----------------------------

B65D 50/04

requiring the combination of simultaneous actions, e.g. depressing and turning, lifting and turning, maintaining a part and turning another one ({[B65D 55/02](#)} takes precedence; caps or covers secured by rotation with bayonet cams [B65D 41/06](#), [B65D 41/36](#))

References

Informative references

Attention is drawn to the following places, which may be of interest for search:

Child-proof means requiring the combination of simultaneous actions	B65D 2215/02
---	------------------------------

B65D 50/041

{the closure comprising nested inner and outer caps or an inner cap and an outer coaxial annular member, which can be brought into engagement to enable removal by rotation}

Definition statement

This place covers:

Illustrative example of subject matter classified in this group:

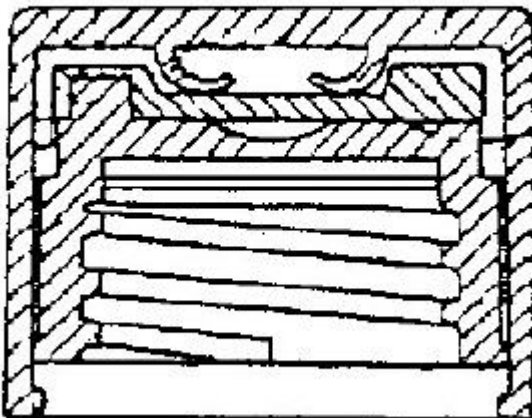

References

Informative references

Attention is drawn to the following places, which may be of interest for search:

The closure comprising an inner closure and a freely rotating outer cap or sleeve whereby a tool, key or the like is inserted between the two closure elements to enable removal of the closure	B65D 50/068
---	-----------------------------

B65D 50/043

{the closure comprising a screw cap whose threads are shaped to accommodate blocking elements and the closure is removed after first applying axial force to unblock it and allow it to be unscrewed}

Definition statement

This place covers:

Illustrative example of subject matter classified in this group:

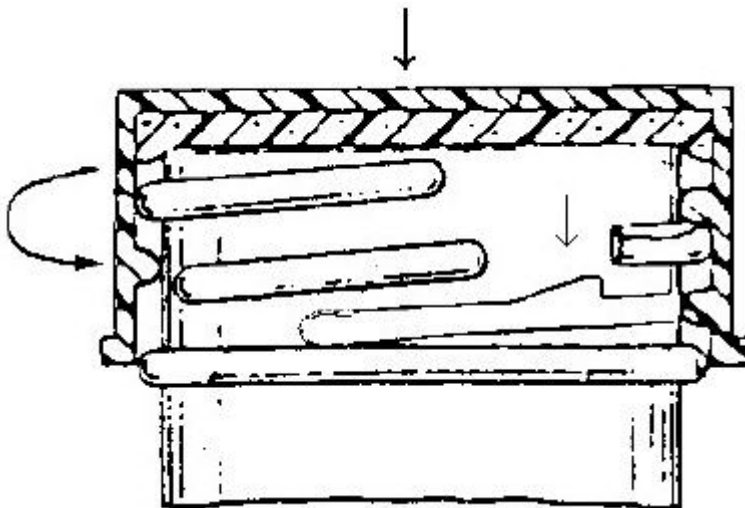

References

Informative references

Attention is drawn to the following places, which may be of interest for search:

Threaded or like caps or cap-like covers secured by rotation with means for positioning the cap on the container, or for limiting the movement of the cap, or for preventing accidental loosening of the cap	B65D 41/0471
--	------------------------------

B65D 50/045

{where one action elastically deforms or deflects at least part of the closure, the container or an intermediate element, e.g. a ring ([B65D 50/041](#), [B65D 50/043](#) take precedence)}

Definition statement

This place covers:

Illustrative example of subject matter classified in this group:

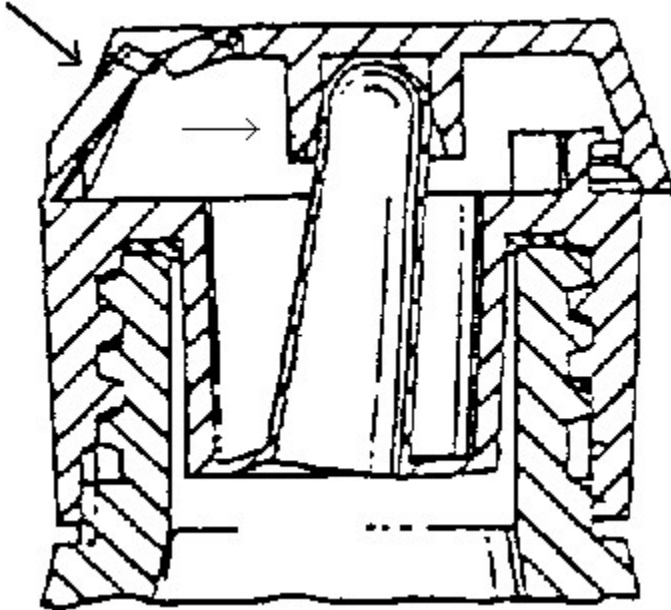

References

Limiting references

This place does not cover:

The closure comprising nested inner and outer caps or an inner cap and an outer coaxial annular member, which can be brought into engagement to enable removal by rotation	B65D 50/041
The closure comprising a screw cap whose threads are shaped to accommodate blocking elements and the closure is removed after first applying axial force to unblock it and allow it to be unscrewed	B65D 50/043

B65D 50/046

{and such deformation causes the disengagement of locking means, e.g. the release of a pawl-like element from a tooth or abutment, to allow removal of the closure by simultaneous rotation}

Definition statement

This place covers:

Illustrative example of subject matter classified in this group:

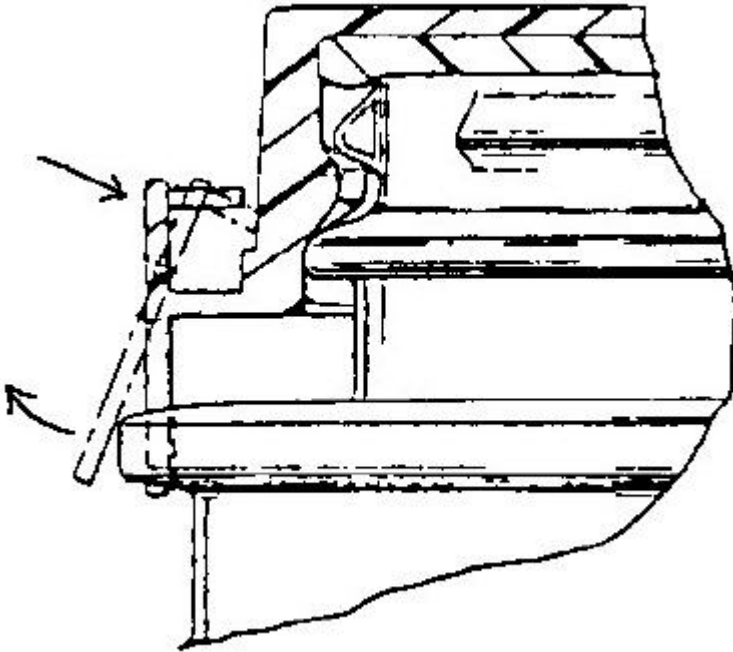

B65D 50/048

{and such deformation causes the engagement of means, e.g. threads, to allow removal of the closure by simultaneous rotation}

Definition statement

This place covers:

Illustrative example of subject matter classified in this group:

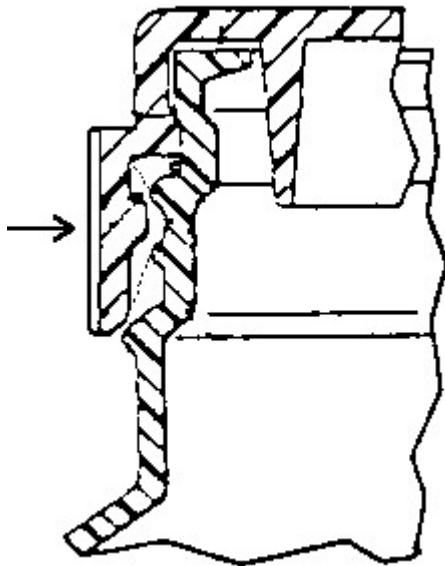
**B65D 50/061**

{being disengageable from container only after rotational alignment of closure, or other means inhibiting removal of closure, with container, e.g. tortuous path type ([B65D 55/145](#) takes precedence)}

Definition statement

This place covers:

Illustrative example of subject matter classified in this group:

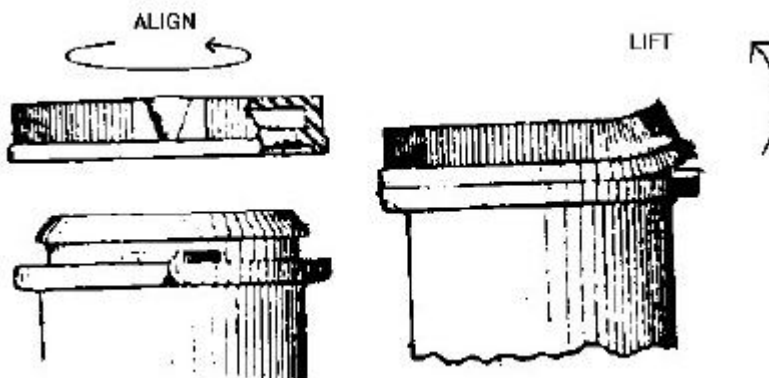

References**Limiting references**

This place does not cover:

Applications of permutation locks	B65D 55/145
-----------------------------------	-----------------------------

B65D 50/062

{the closure removal inhibiting means being a displaceable ring}

Definition statement

This place covers:

Illustrative example of subject matter classified in this group:

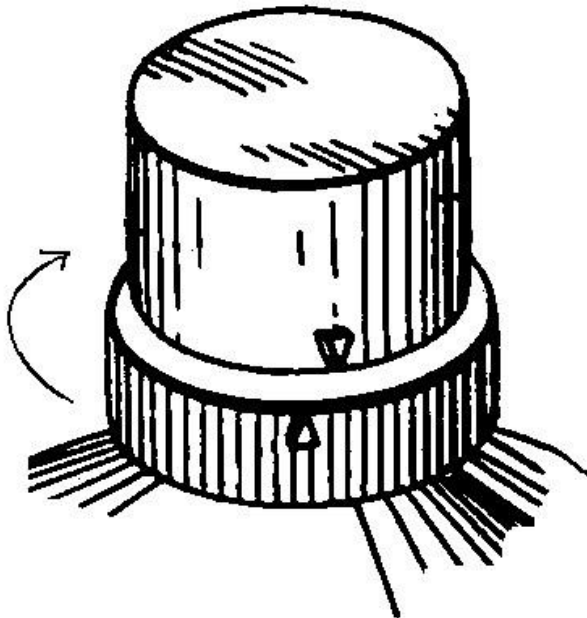

B65D 50/063

{the closure or container being provided with two spaced sets of screw threads or the like}

Definition statement

This place covers:

Illustrative example of subject matter classified in this group:

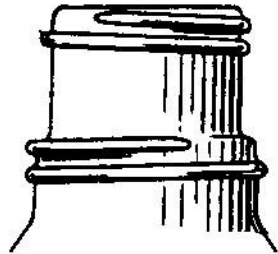
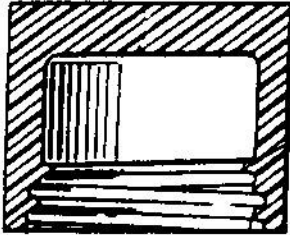

B65D 50/064

{at least one of the sets of threads being formed in a separate ring}

Definition statement

This place covers:

Illustrative example of subject matter classified in this group:

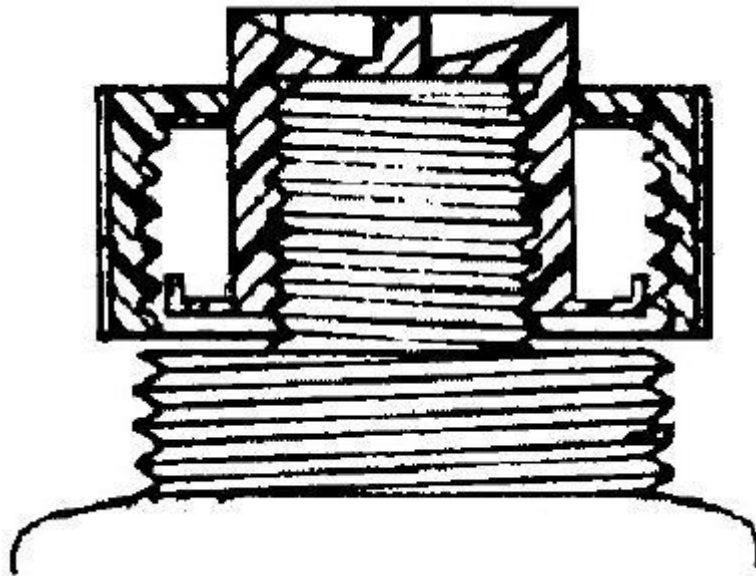
**B65D 50/065**

{with separate ring having to be axially displaced to permit user to access closure ([B65D 50/062](#), [B65D 50/064](#) take precedence; radial pressure applying means [B65D 45/32](#))}

Definition statement

This place covers:

Illustrative example of subject matter classified in this group:

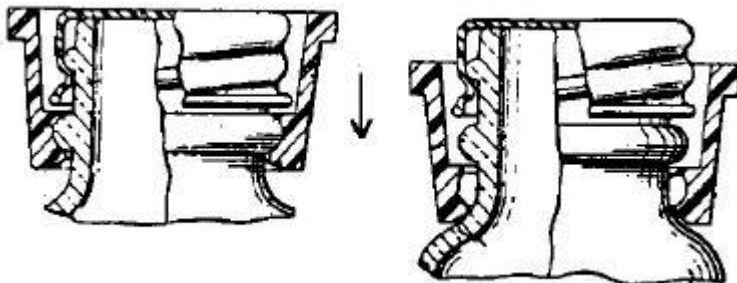
**References****Limiting references**

This place does not cover:

The closure removal inhibiting means being a displaceable ring	B65D 50/062
--	-----------------------------

At least one of the sets of threads being formed in a separate ring	B65D 50/064
---	-----------------------------

B65D 50/066

{whereby parts of the container or closure having to be deformed, i.e. bi-stable movement ([B65D 50/045](#) takes precedence)}

Definition statement

This place covers:

Illustrative example of subject matter classified in this group:

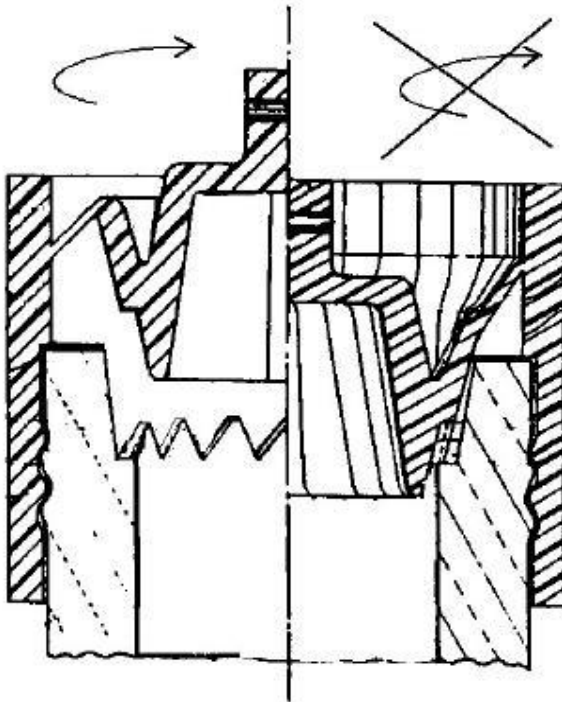

References

Limiting references

This place does not cover:

Where one action elastically deforms or deflects at least part of the closure, the container or an intermediate element	B65D 50/045
---	-----------------------------

B65D 50/067

{using integral or non-integral accessories, e.g. tool, key ([B65D 50/062](#), [B65D 50/064](#), [B65D 50/065](#) take precedence)}

References**Limiting references**

This place does not cover:

The closure removal inhibiting means being a displaceable ring	B65D 50/062
At least one of the sets of threads being formed in a separate ring	B65D 50/064
With separate ring having to be axially displaced to permit user to access closure	B65D 50/065

Informative references

Attention is drawn to the following places, which may be of interest for search:

Means for facilitating removing of the closure by means of a coin or other tool in recesses or similar on container or lid	B65D 2543/00898
--	---------------------------------

B65D 50/068

{the closure comprising an inner closure and a freely rotating outer cap or sleeve whereby a tool, key or the like is inserted between the two closure elements to enable removal of the closure}

Definition statement

This place covers:

Illustrative example of subject matter classified in this group:

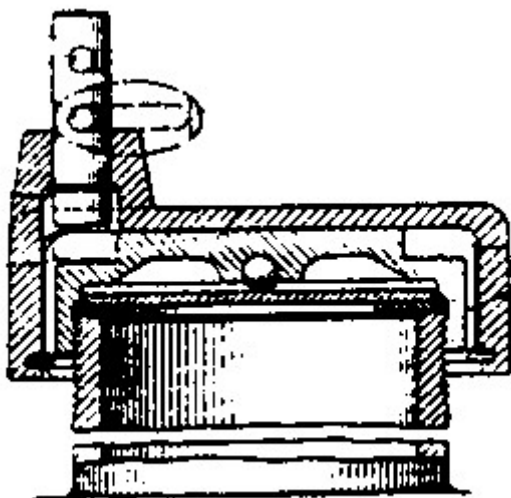

References

Informative references

Attention is drawn to the following places, which may be of interest for search:

The closure comprising nested inner and outer caps or an inner cap and an outer coaxial annular member, which can be brought into engagement to enable removal by rotation	B65D 50/041
--	-----------------------------

B65D 50/069

{the closure being provided with a retractable element whereby the closure is removed by extending or raising the retractable element and exerting a lifting force on this element}

Definition statement

This place covers:

Illustrative example of subject matter classified in this group:

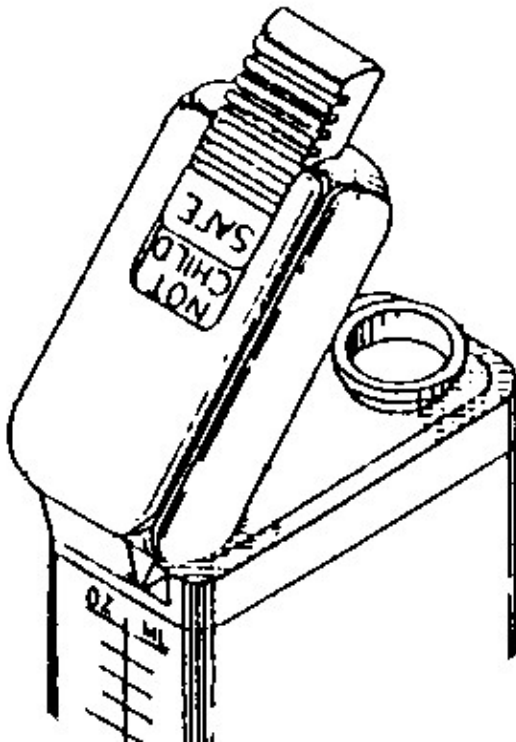

References

Informative references

Attention is drawn to the following places, which may be of interest for search:

Requiring the combination of simultaneous actions, e.g. depress and turn, lift and turn, maintain a part and turn another one	B65D 50/04
---	----------------------------

B65D 51/00

Closures not otherwise provided for (covers or similar closures as engineering elements for pressure vessels in general [F16J 13/00](#))

References**Limiting references**

This place does not cover:

Closures having deformable parts for neutralising internal pressure variations	B65D 79/005
--	-----------------------------

B65D 51/002

{Closures to be pierced by an extracting-device for the contents and fixed on the container by separate retaining means}

Definition statement

This place covers:

Illustrative example of subject matter classified in this group:

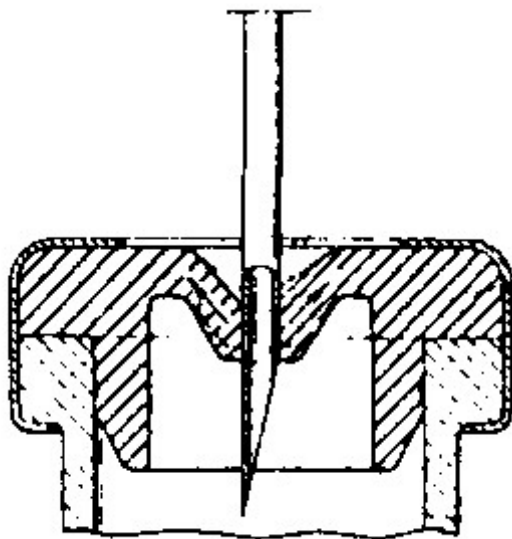
**References****Informative references**

Attention is drawn to the following places, which may be of interest for search:

The partition being in the form of a plug or the like which is removed by increasing or decreasing the pressure within the container	B65D 25/082
Caps or cap-like covers with membranes	B65D 41/20
Details, e.g. inlet or outlet ports, provisions for hanging, shape retaining means	A61J 1/14
Septums, pierceable membranes	A61J 1/1406

B65D 51/005

{Closures provided with linings or internal coatings so as to avoid contact of the closure with the contents}

Definition statement

This place covers:

Illustrative example of subject matter classified in this group:

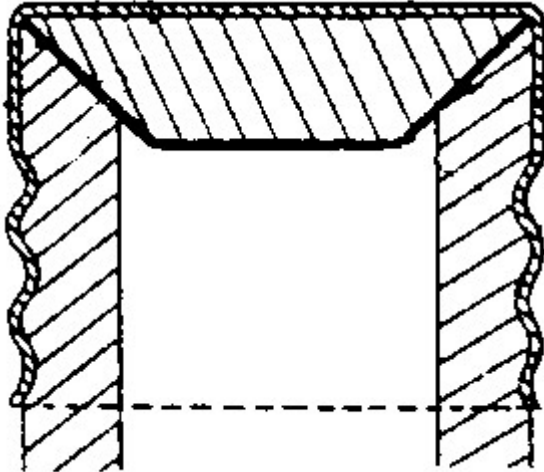

B65D 51/007

{Separate closure devices for reclosing opened cans or tins, e.g. beer cans}

Definition statement

This place covers:

Illustrative example of subject matter classified in this group:

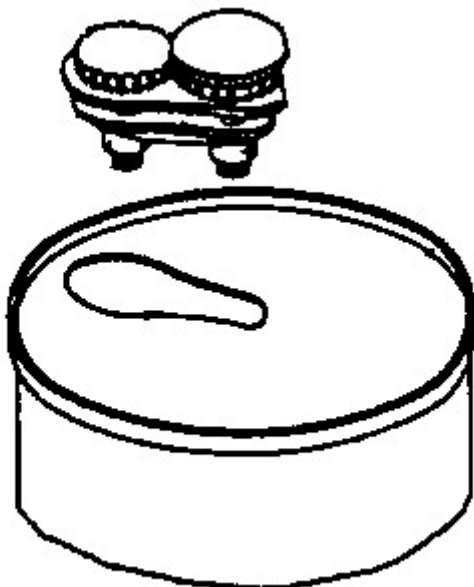

References

Informative references

Attention is drawn to the following places, which may be of interest for search:

Rigid or semi-rigid members	B65D 17/506
Two or more closures	B65D 2251/0003
Reclosable openings with the plug being reinsertable into the opening	B65D 2517/0038
Reclosable openings by means of an additional element in the form of a plug	B65D 2517/0043

B65D 51/04

hinged ([B65D 51/10](#) takes precedence)

Definition statement

This place covers:

Illustrative example of subject matter classified in this group:

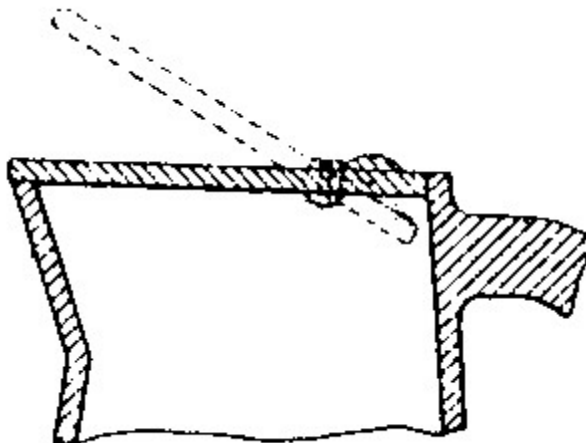

References

Limiting references

This place does not cover:

Loosely-engaging lids or covers for jars, cans, or like opening automatically when container is tilted for pouring	B65D 51/10
--	----------------------------

B65D 51/08

with axial projections fitting within, or around, the walls defining the openings, e.g. for milk churns

Definition statement

This place covers:

Illustrative example of subject matter classified in this group:

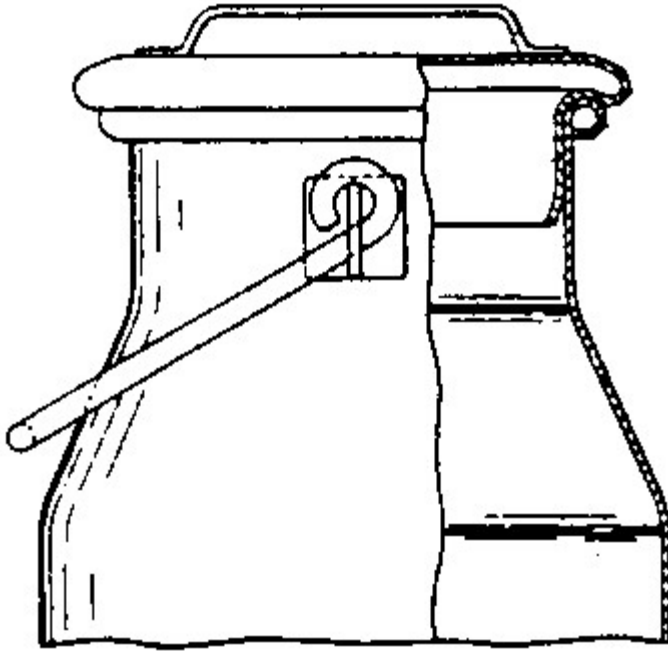

B65D 51/10

opening automatically when container is tilted for pouring

Definition statement

This place covers:

Illustrative example of subject matter classified in this group:

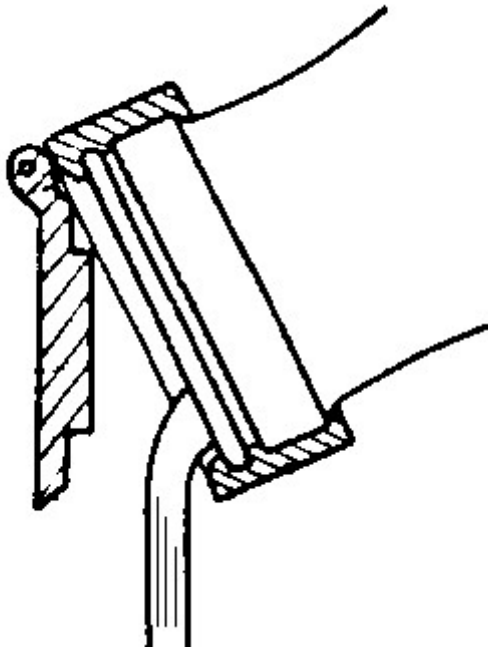
**References****Limiting references**

This place does not cover:

Floating covers	B65D 81/245
-----------------	-----------------------------

B65D 51/14

Rigid discs or spherical members adapted to be held in sealing engagement with mouth of container, e.g. closure plates for preserving jars

Definition statement

This place covers:

Illustrative example of subject matter classified in this group:

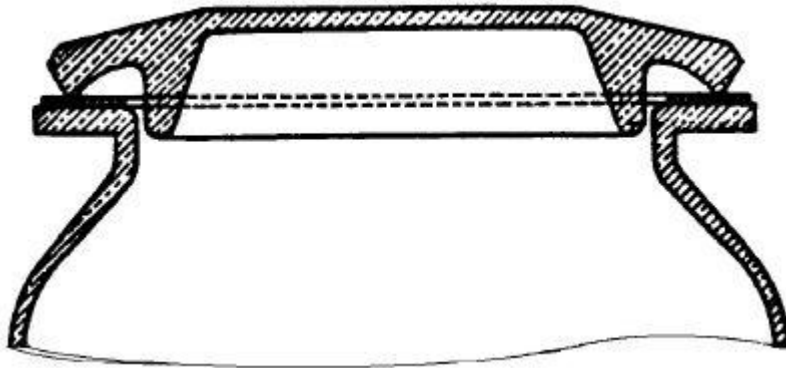

References

Limiting references

This place does not cover:

By means of an additional element connected directly to the container	B65D 51/145
---	-----------------------------

Informative references

Attention is drawn to the following places, which may be of interest for search:

Annular members	B65D 45/30
Lever-operated contractible or expansible band, the lever moving in the plane of the band	B65D 45/345
Disc closures	B65D 2543/00037

B65D 51/145**{by means of an additional element connected directly to the container}****Definition statement***This place covers:*

Illustrative example of subject matter classified in this group:

**References****Informative references***Attention is drawn to the following places, which may be of interest for search:*

Annular members	B65D 45/30
Lever-operated contractible or expansible band, the lever moving in the plane of the band	B65D 45/345

B65D 51/16**with means for venting air or gas****References****Limiting references***This place does not cover:*

Spouts with air inlet	B65D 25/40 , B65D 47/06
Not included in a closure	B65D 33/00 , B65D 77/225 , B65D 81/20
E.g. closures for neutralising internal pressure variations	B65D 79/005
Venting means in general	B65D 2205/00
Milk churns with venting means	A01G
Feeding bottles with means for supplying air	A61J 9/04
Pumping means for creating a vacuum or superpressure	B65B 31/00
Wine fermentation closure	C12G
Venting devices for casks, barrels or the like	C12L 9/00

Informative references

Attention is drawn to the following places, which may be of interest for search:

With means for venting not comprising a valve	B65D 47/32
---	----------------------------

B65D 51/1611

{by means of an orifice, capillary or labyrinth passage ([B65D 51/1616](#), [B65D 51/1622](#) take precedence)}

Definition statement

This place covers:

Illustrative example of subject matter classified in this group:

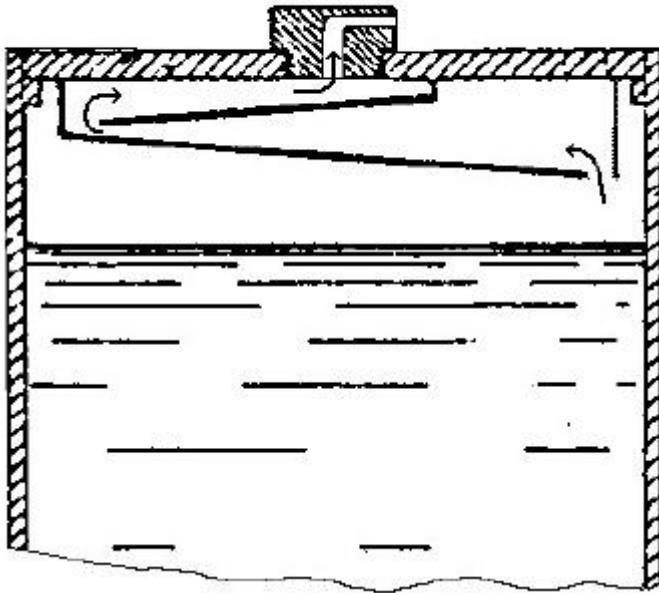

DE162516

References**Limiting references**

This place does not cover:

Venting air or gas by means of a filter	B65D 51/1616
Venting air or gas by means of a passage for the escape of gas between the closure and the lip of the container mouth	B65D 51/1622
Venting holes without details	B65D 2205/02

B65D 51/1616**{by means of a filter}****Definition statement***This place covers:*

Illustrative example of subject matter classified in this group:

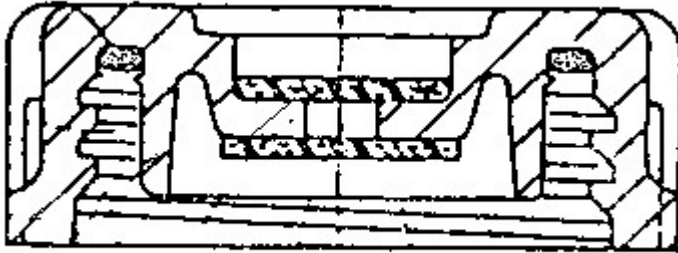
**B65D 51/1622****{by means of a passage for the escape of gas between the closure and the lip of the container mouth}****Definition statement***This place covers:*

Illustrative example of subject matter classified in this group:

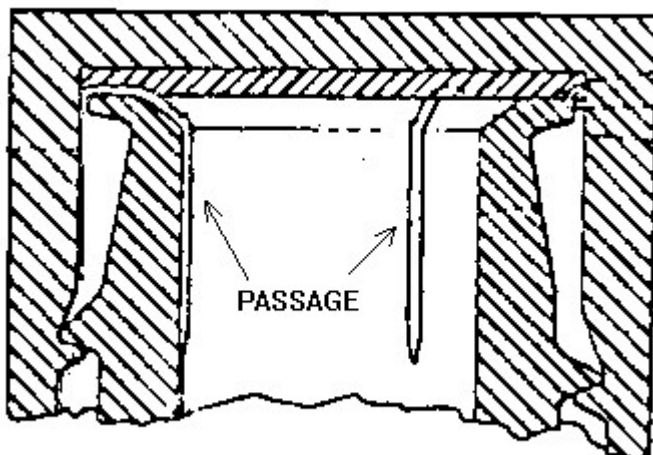
**References****Informative references***Attention is drawn to the following places, which may be of interest for search:*

Threaded or like caps or cap-like covers secured by rotation	B65D 41/04
By means of a passage for the escape of gas between the closure and the lip of the container mouth	B65D 51/1661

Venting occurring during initial closing or opening of the container, by means of a passage for the escape of gas between the closure and the lip of the container mouth, e.g. interrupted threads	B65D 51/1688
--	------------------------------

B65D 51/1627

{the closure being for a box-like container}

Definition statement

This place covers:

Illustrative example of subject matter classified in this group:

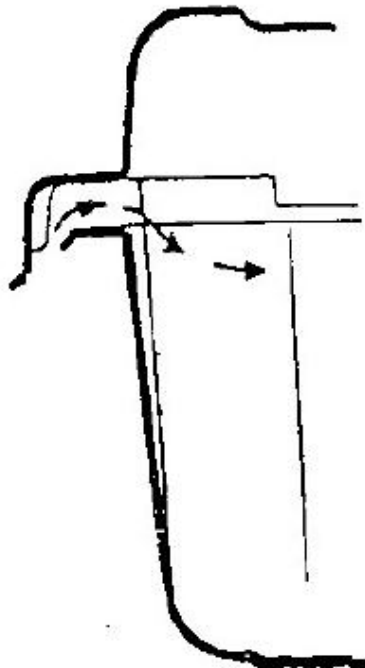

References

Informative references

Attention is drawn to the following places, which may be of interest for search:

The closure being for a box-like container	B65D 51/1666
The closure being for a box-like container	B65D 51/1694

B65D 51/1633

{whereby venting occurs by automatic opening of the closure, container or other element}

References**Limiting references**

This place does not cover:

Pressure relief valves	F16K 17/00
------------------------	----------------------------

B65D 51/1638

{by means of an element bursting upon a predetermined pressure in the container being exceeded}

Definition statement

This place covers:

Illustrative example of subject matter classified in this group:

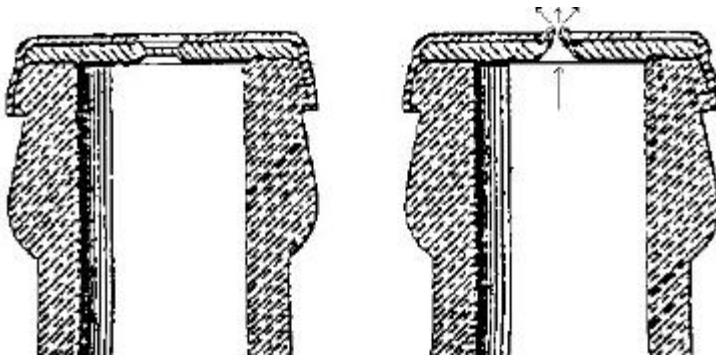
**References****Informative references**

Attention is drawn to the following places, which may be of interest for search:

Venting air or gas by rupturing a portion of the closure	B65D 51/1677
--	------------------------------

B65D 51/1644

{the element being a valve ([B65D 51/1661](#) takes precedence)}

Definition statement

This place covers:

Illustrative example of subject matter classified in this group:

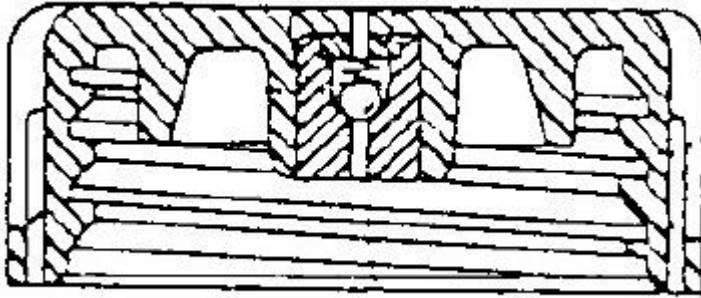
**References****Limiting references**

This place does not cover:

For venting valves according	B65D 47/205
Venting air or gas by means of a passage for the escape of gas between the closure and the lip of the container mouth	B65D 51/1661
Pressure relief valves	F16K 17/00

Informative references

Attention is drawn to the following places, which may be of interest for search:

Hand-operated members for controlling dischargecomprising a valve or like element which is opened or closed by deformation of the container or closure	B65D 47/2018
The valve being formed by a tubular flexible sleeve surrounding a rod-like element provided with at least one radial passageway which is normally closed by the sleeve	B65D 47/205
Pressure relief-valves incorporated in a container wall, e.g. valves comprising at least one elastic element	B65D 77/225

B65D 51/165**{formed by a slit or narrow opening}****Definition statement***This place covers:*

Illustrative example of subject matter classified in this group:

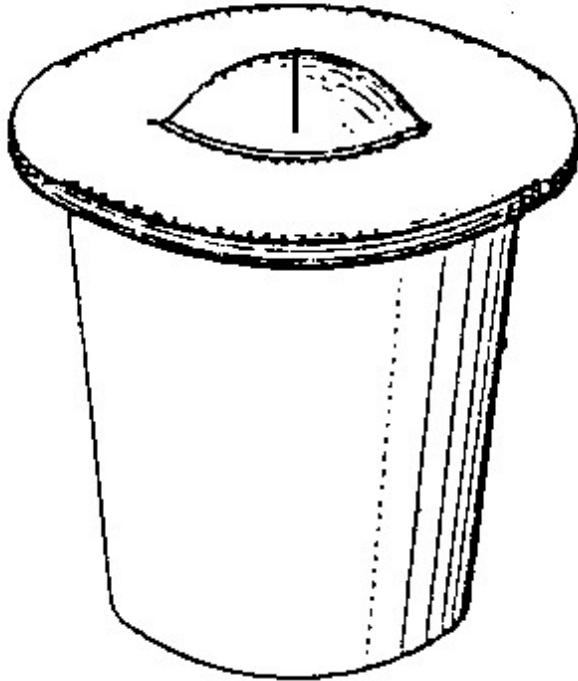
**References*****Informative references****Attention is drawn to the following places, which may be of interest for search:*

The element being formed by a slit, narrow opening or constrictable spout, the size of the outlet passage being able to be varied by increasing or decreasing the pressure	B65D 47/2031
--	------------------------------

B65D 51/1655

{formed by an elastic band closing an opening in a tubular part of the closure encircled by said band}

Definition statement

This place covers:

Illustrative example of subject matter classified in this group:

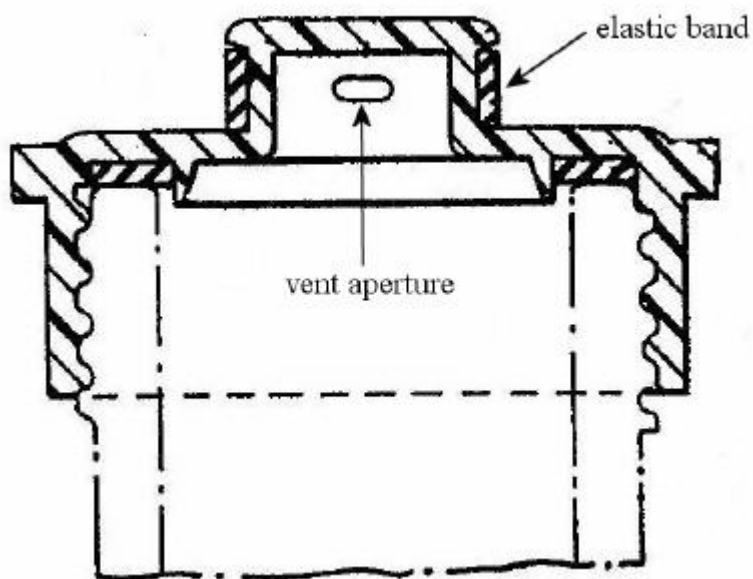

References

Limiting references

This place does not cover:

Valves being formed by a tubular flexible sleeve surrounding a rod-like element	B65D 47/205
---	-----------------------------

B65D 51/1661

{by means of a passage for the escape of gas between the closure and the lip of the container mouth}

Definition statement

This place covers:

Illustrative example of subject matter classified in this group:

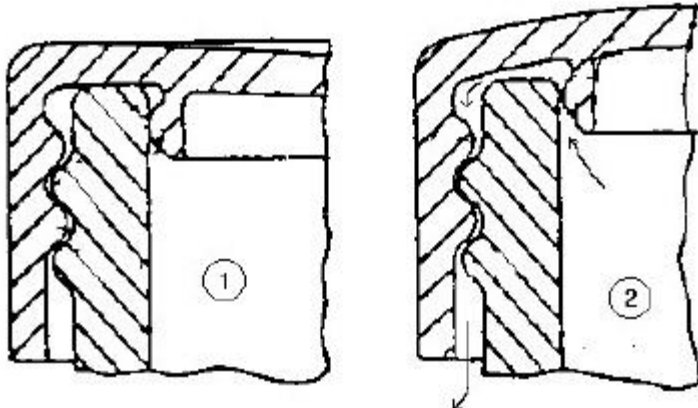
**References****Informative references**

Attention is drawn to the following places, which may be of interest for search:

Threaded or like caps or cap-like covers secured by rotation	B65D 41/04
Venting air or gas by means of a passage for the escape of gas between the closure and the lip of the container mouth	B65D 51/1622
Venting occurring during initial closing or opening of the container, by means of a passage for the escape of gas between the closure and the lip of the container mouth	B65D 51/1688

B65D 51/1666**{the closure being for a box-like container}****Definition statement***This place covers:*

Illustrative example of subject matter classified in this group:

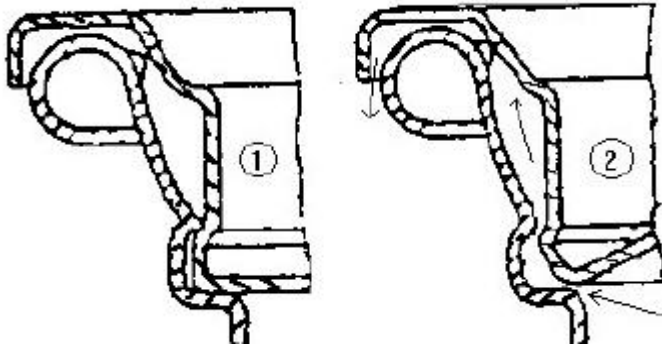
**References****Informative references***Attention is drawn to the following places, which may be of interest for search:*

Venting air or gas the closure being for a box-like container	B65D 51/1627
Venting occurring during initial closing or opening of the container, by means of a passage for the escape of gas between the closure and the lip of the container mouth, e.g. interrupted threads, the closure being for a box-like container	B65D 51/1694

B65D 51/1677**{by rupturing a portion of the closure}****Definition statement***This place covers:*

Illustrative example of subject matter classified in this group:

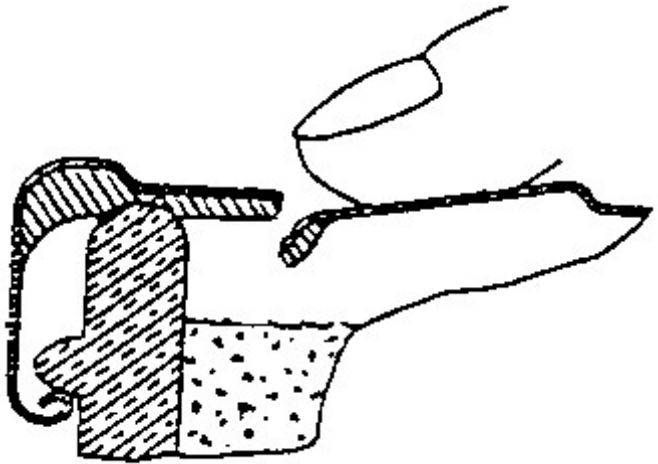
**References****Informative references***Attention is drawn to the following places, which may be of interest for search:*

Opening arrangements or devices for tearing along a line or from a point of weakness provided in an end wall	B65D 17/401
Attached can-cutting devices	B65D 17/521
Venting air or gas by means of an element bursting upon a predetermined pressure in the container being exceeded	B65D 51/1638

B65D 51/1683

{by actuating a separate element in the container or closure}

Definition statement

This place covers:

Illustrative example of subject matter classified in this group:

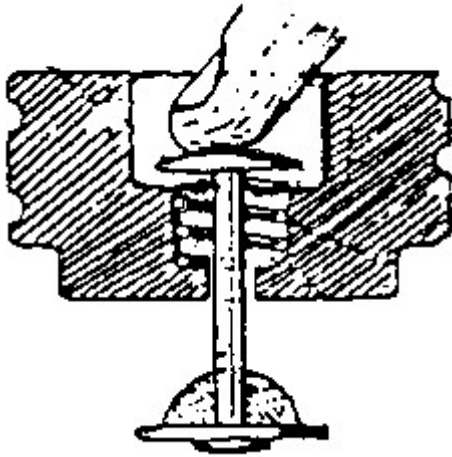

B65D 51/1688

{Venting occurring during initial closing or opening of the container, by means of a passage for the escape of gas between the closure and the lip of the container mouth, e.g. interrupted threads}

Definition statement

This place covers:

Illustrative example of subject matter classified in this group:

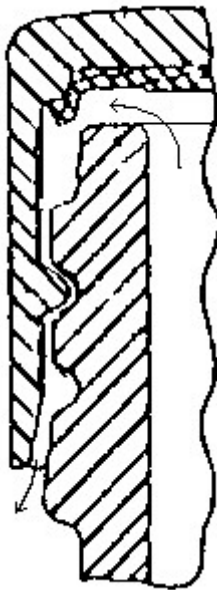

References

Informative references

Attention is drawn to the following places, which may be of interest for search:

Closures arranged within necks or pouring openings or in discharge apertures	B65D 39/00
Threaded or like caps or cap-like covers secured by rotation	B65D 41/04
Venting air or gas by means of a passage for the escape of gas between the closure and the lip of the container mouth	B65D 51/1622
Venting air or gas by means of a passage for the escape of gas between the closure and the lip of the container mouth	B65D 51/1661
Closures provided with freeze-drying means	B65D 51/241

B65D 51/1694**{the closure being for a box-like container}****Definition statement***This place covers:*

Illustrative example of subject matter classified in this group:

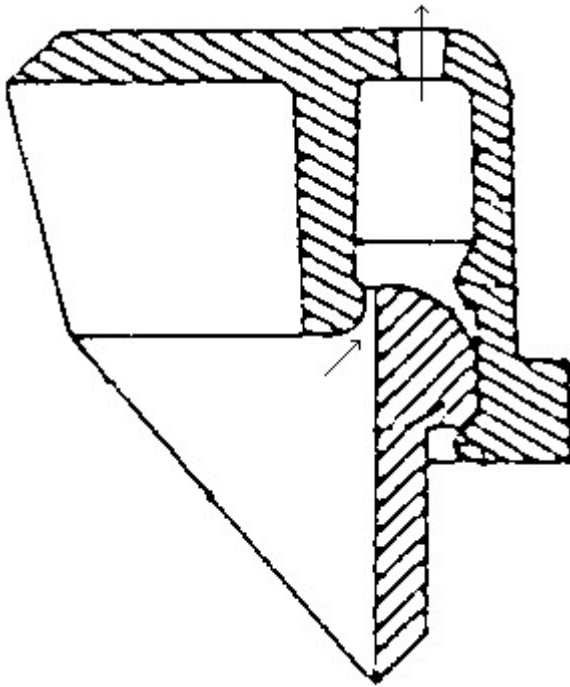
**References****Informative references***Attention is drawn to the following places, which may be of interest for search:*

Venting air or gas the closure being for a box-like container	B65D 51/1627
Venting air or gas by means of a passage for the escape of gas between the closure and the lip of the container mouth the closure being for a box-like container	B65D 51/1666

B65D 51/18

Arrangements of closures with protective outer cap-like covers or of two or more co-operating closures {(B65D 51/247 takes precedence)}

Definition statement

This place covers:

Illustrative example of subject matter classified in this group:

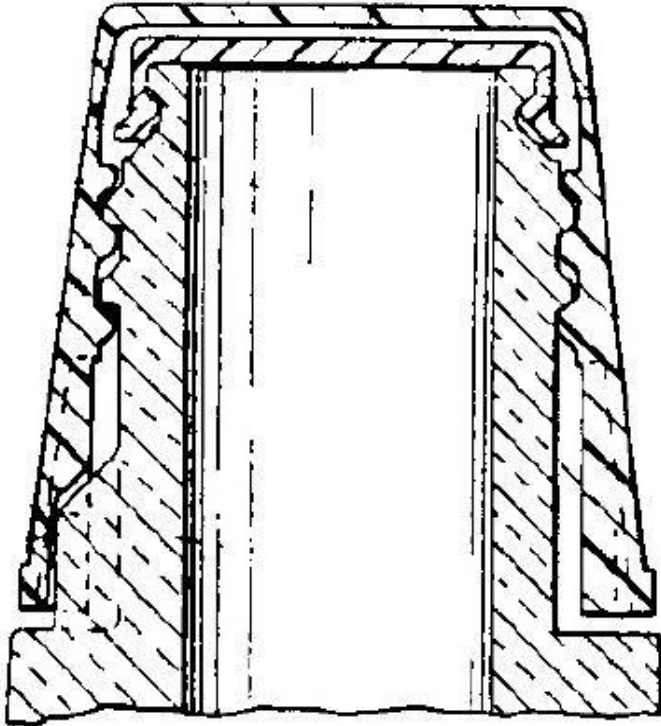

US4280631

References**Limiting references**

This place does not cover:

Bags	B65D 31/005
The closure comprising nested inner and outer caps or an inner cap and an outer coaxial annular member, which can be brought into engagement to enable removal by rotation	B65D 50/041
Closures combined with auxiliary devices for non-closing purposes, provided with eating utensils or spatulas, located between an inner and an outer closure	B65D 51/247

Informative references

Attention is drawn to the following places, which may be of interest for search:

Caps combined with stoppers	B65D 41/28
Caps or cap-like covers combined with stoppers	B65D 41/58

Special rules of classification

The use of available Indexing Codes is mandatory.

B65D 51/185

{the outer closure being a foil membrane}

Definition statement

This place covers:

Illustrative example of subject matter classified in this group:

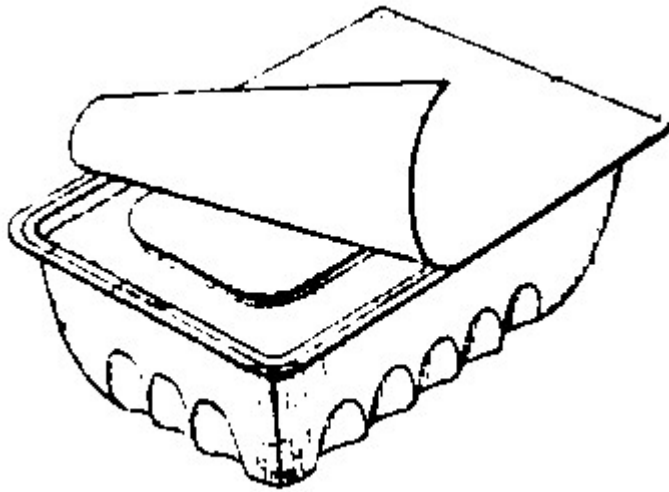

Special rules of classification

The use of available Indexing Codes is mandatory.

B65D 51/20

Caps, lids, or covers co-operating with an inner closure arranged to be opened by piercing, cutting, or tearing {([B65D 51/185](#) takes precedence; co-operating with an auxiliary container for additional articles or materials [B65D 51/28](#)}

Definition statement

This place covers:

Illustrative example of subject matter classified in this group:

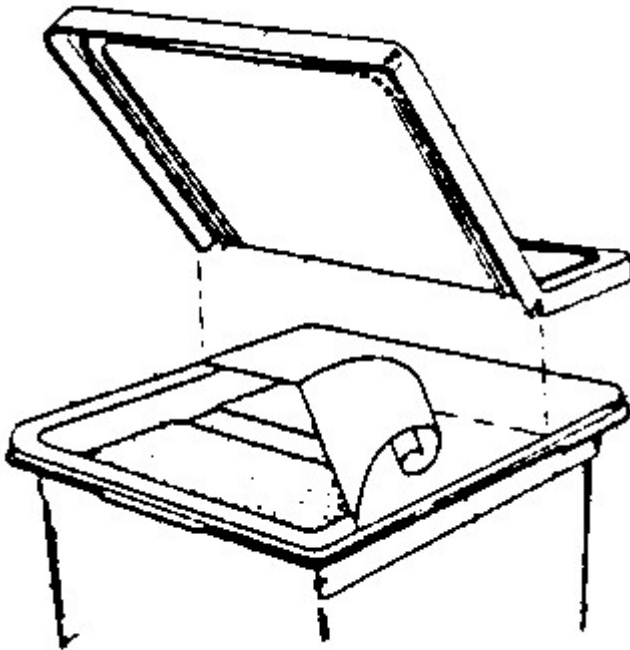

References

Limiting references

This place does not cover:

For reclosing open cans, tins	B65D 51/007
Arrangements of closures with protective outer cap-like covers or of two or more co-operating closures the outer closure being a foil membrane	B65D 51/185

Special rules of classification

The use of available Indexing Codes is mandatory.

B65D 51/22

having means for piercing, cutting, or tearing the inner closure

References**Limiting references**

This place does not cover:

Piercing or tearing independent from the cap	B65D 51/20
Closures also fulfilling the function of a container	B65D 51/2807

Informative references

Attention is drawn to the following places, which may be of interest for search:

Spouts with means for piercing or cutting the container wall or a membrane connected to said wall	B65D 5/747
Closures with devices for removing frangible parts of the pouring element or of its closure	B65D 47/106
Closures with frangible parts adapted to be pierced, torn, or removed, to provide discharge openings	B65D 47/36

Special rules of classification

The use of available Indexing Codes is mandatory.

B65D 51/221

{a major part of the inner closure being left inside the container after the opening}

References**Informative references**

Attention is drawn to the following places, which may be of interest for search:

Opening arrangements or devices for tearing along a line or from a point of weakness provided in an end wall	B65D 17/401
Attached can-cutting devices	B65D 17/521

Special rules of classification

The use of available Indexing Codes is mandatory.

B65D 51/222

{the piercing or cutting means being integral with, or fixedly attached to, the outer closure}

Definition statement

This place covers:

Illustrative example of subject matter classified in this group:

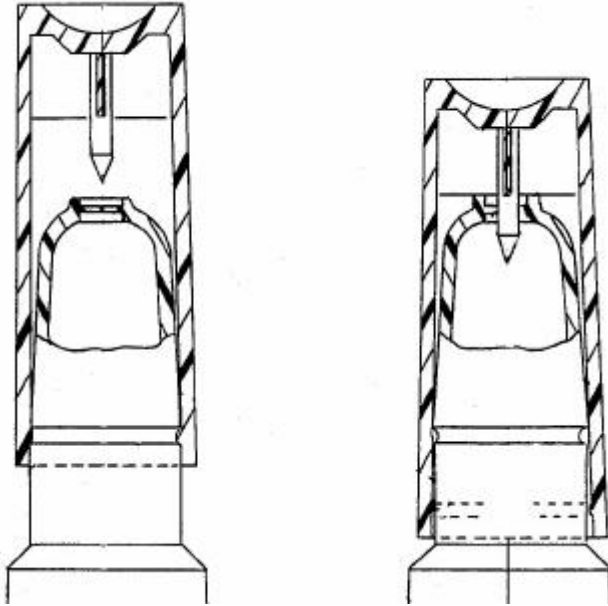

Special rules of classification

The use of available Indexing Codes is mandatory.

B65D 51/223

{the outer closure having to be removed or inverted for piercing or cutting}

Definition statement

This place covers:

Illustrative example of subject matter classified in this group:

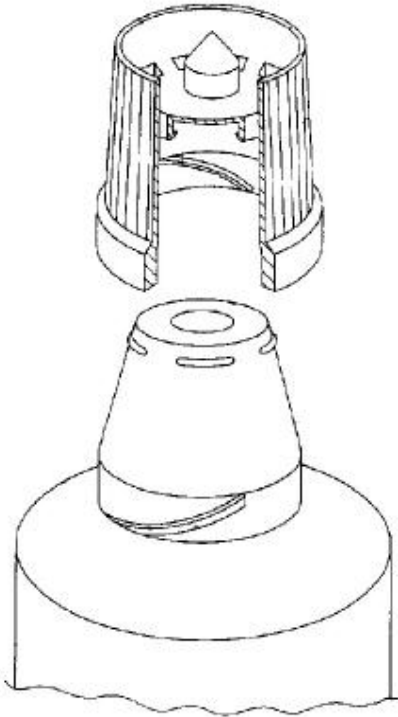

Special rules of classification

The use of available Indexing Codes is mandatory.

B65D 51/224

{the outer closure comprising flexible parts ([B65D 51/223](#) takes precedence)}

Definition statement

This place covers:

Illustrative example of subject matter classified in this group:

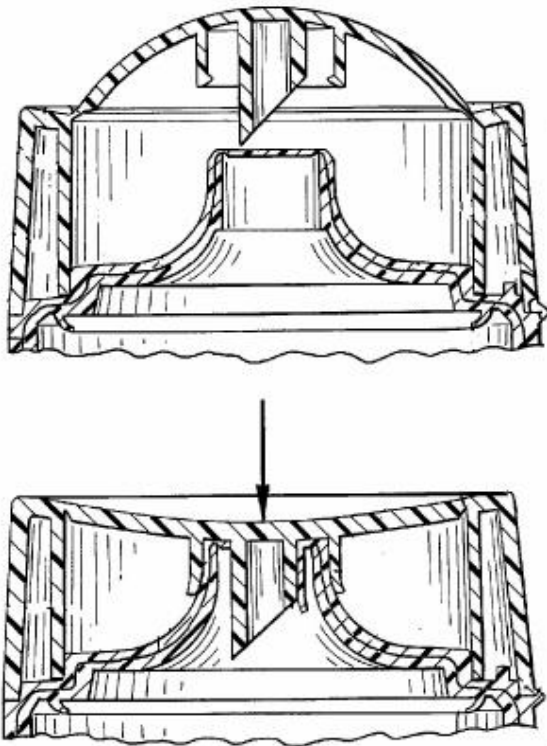
**References****Limiting references**

This place does not cover:

Caps, lids, or covers co-operating with an inner closure arranged to be opened by piercing, cutting, or tearing, the outer closure having to be removed or inverted for piercing or cutting	B65D 51/223
---	-----------------------------

Special rules of classification

The use of available Indexing Codes is mandatory.

B65D 51/225

{and further comprising a device first inhibiting displacement of the outer closure ([B65D 51/223](#) takes precedence)}

Definition statement

This place covers:

Illustrative example of subject matter classified in this group:

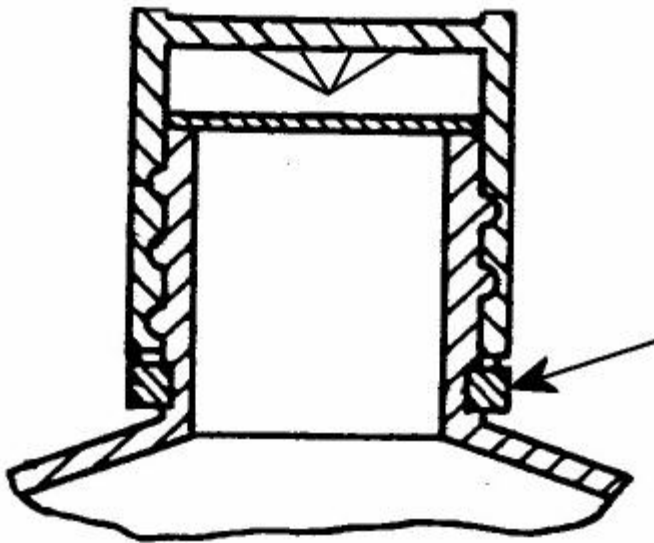
**References****Limiting references**

This place does not cover:

Caps, lids, or covers co-operating with an inner closure arranged to be opened by piercing, cutting, or tearing, the outer closure having to be removed or inverted for piercing or cutting	B65D 51/223
---	-----------------------------

Special rules of classification

The use of available Indexing Codes is mandatory.

B65D 51/227

{and further comprising a device first inhibiting displacement of the piercing or cutting means}

Definition statement

This place covers:

Illustrative example of subject matter classified in this group:

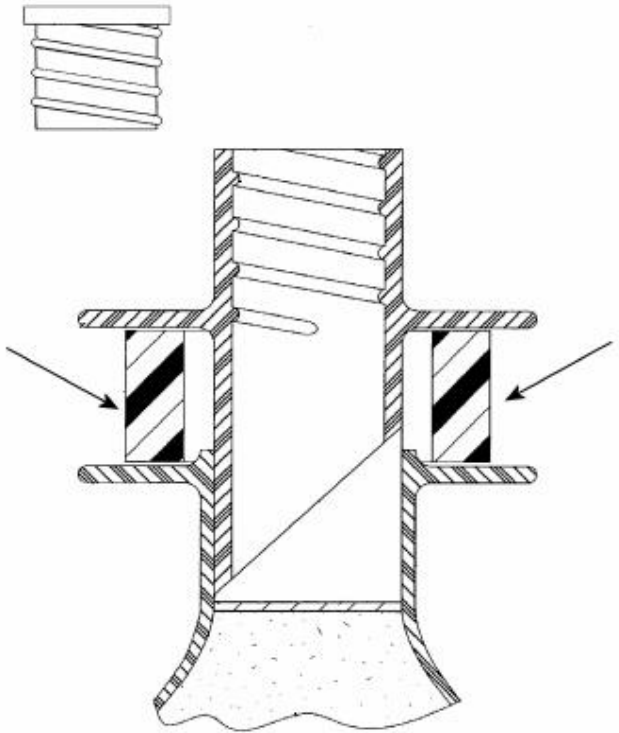
**Special rules of classification**

The use of available Indexing Codes is mandatory.

B65D 51/228

{a major part of the inner closure being removed from the container after the opening}

Definition statement

This place covers:

Illustrative example of subject matter classified in this group:

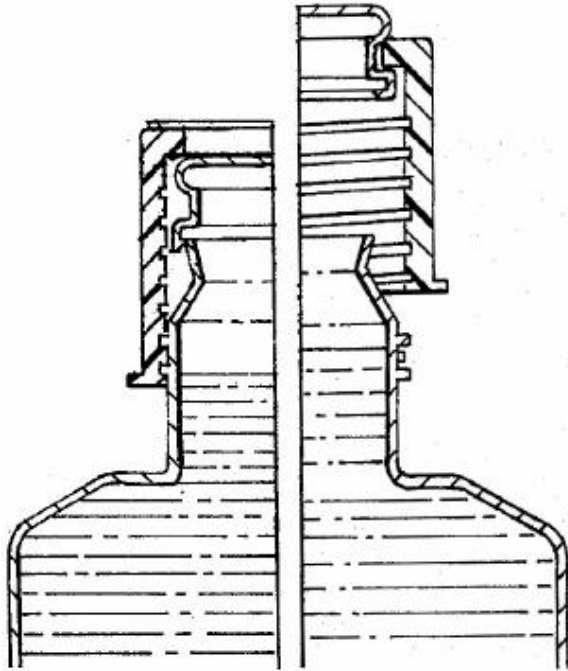
**Special rules of classification**

The use of available Indexing Codes is mandatory.

B65D 51/24

combined {or co-operating} with auxiliary devices for non-closing purposes

References**Limiting references**

This place does not cover:

Containers with a closure presenting stacking elements	B65D 21/0217
Closure openers	B65D 51/243
Oxygen absorbers	B65D 51/244
Advertising	B65D 51/245
Utensils for removing the contents from the package, e.g. spoons, forks, spatulas	B65D 51/246 , B65D 77/245
Spoon-shaped dispensing spouts	B65D 77/245

Closures neutralising pressure variations	B65D 79/005
Closures acting as pill dispensers	B65D 83/049
Spoon-shaped dispensing spouts for administering medicine see also	A61J 7/0015
Measuring spoons	G01F

Informative references

Attention is drawn to the following places, which may be of interest for search:

Closures having pressurising means, i.e. increasing internal pressure	B65D 81/2053 , B65B 31/00 , B65B 31/046
---	--

B65D 51/24

{provided with freeze-drying means}

Definition statement

This place covers:

Illustrative example of subject matter classified in this group:

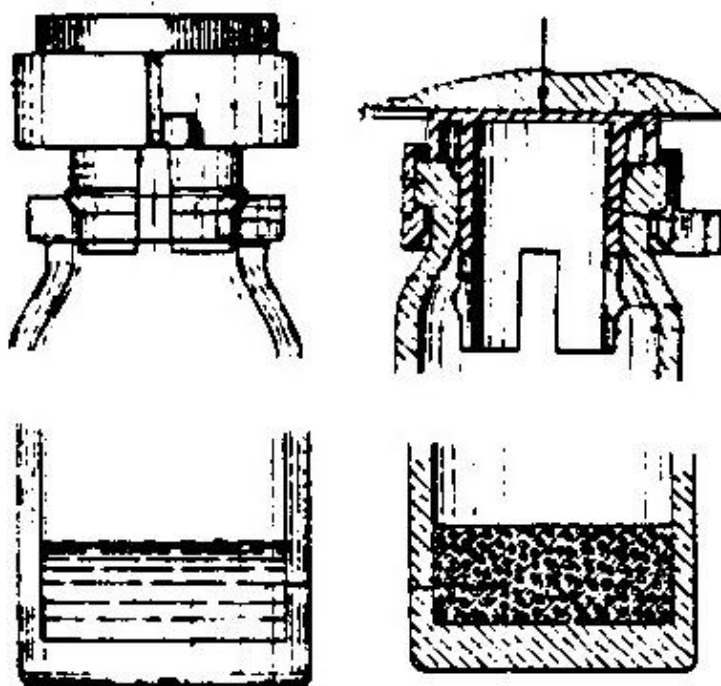
**References****Informative references**

Attention is drawn to the following places, which may be of interest for search:

Closures arranged within necks or pouring openings or in discharge apertures	B65D 39/00
--	----------------------------

B65D 51/242

{provided with means for facilitating lifting or suspending of the container}

Definition statement

This place covers:

Illustrative example of subject matter classified in this group:

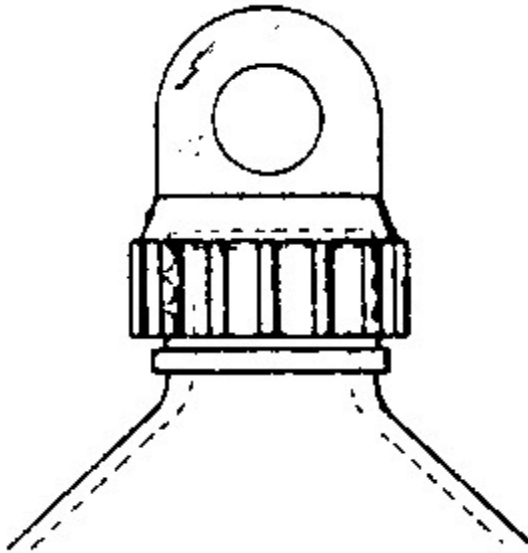

B65D 51/243

{combined with an opening device ([B65D 51/22](#) takes precedence)}

Definition statement

This place covers:

Illustrative example of subject matter classified in this group:

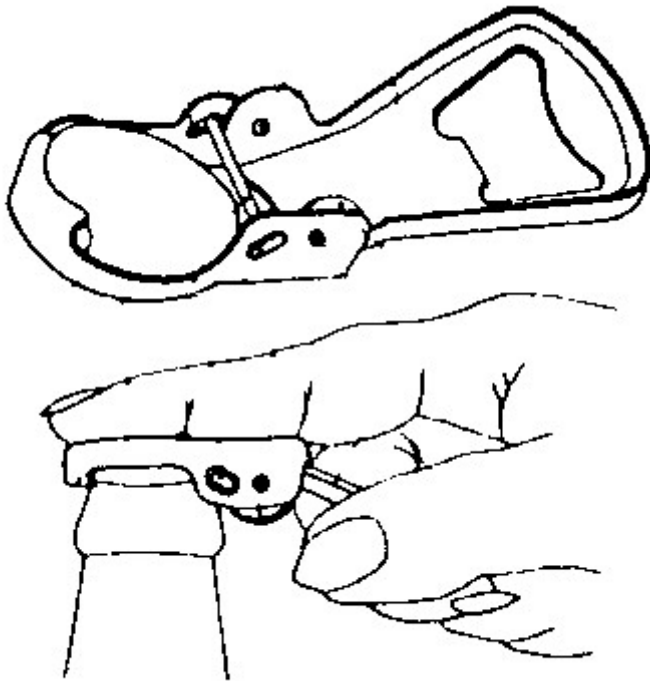
**References****Limiting references**

This place does not cover:

Threaded caps with means specially adapted for facilitating the operation of opening or closing	B65D 41/0485
Caps, lids, or covers co-operating with an inner closure having means for piercing, cutting, or tearing the inner closure	B65D 51/22

B65D 51/245

{provided with decoration, information or contents indicating devices, labels
([B65D 81/366](#) takes precedence)}

Definition statement

This place covers:

Illustrative example of subject matter classified in this group:

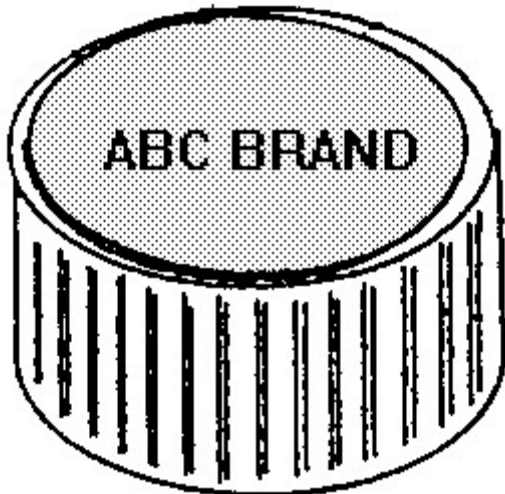
**References****Limiting references**

This place does not cover:

The container closure only being provided with a three dimensional figure, e.g. chess piece, animal	B65D 81/366
---	-----------------------------

Informative references

Attention is drawn to the following places, which may be of interest for search:

Means for the attachment of tags	B65D 23/14
Means for the attachment of labels, cards, coupons or the like	B65D 25/205
Cards, coupons, or other inserts or accessories	B65D 75/54

B65D 51/246

{provided with eating utensils or spatulas (applicator rods or brushes [B65D 51/32](#))}

Definition statement

This place covers:

Illustrative example of subject matter classified in this group:

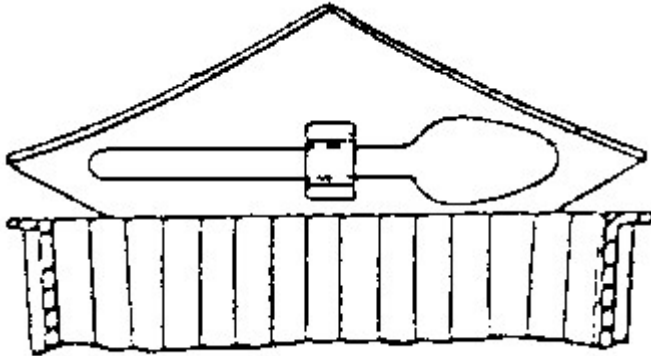
**References****Informative references**

Attention is drawn to the following places, which may be of interest for search:

Utensils for removing the contents from the package	B65D 77/245
Containers for delivering jam, mustard, or the like, combined with a spreading implement	A47G 19/186

B65D 51/247

{located between an inner and an outer closure}

Definition statement

This place covers:

Illustrative example of subject matter classified in this group:

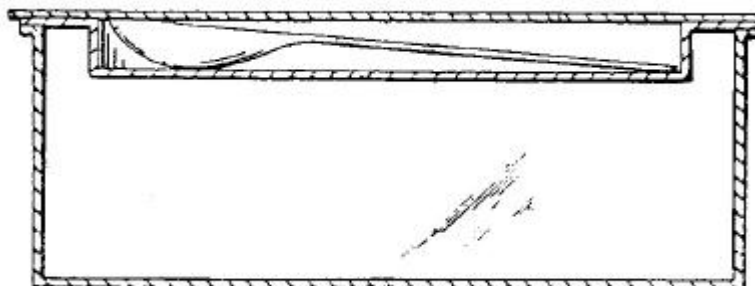

References

Informative references

Attention is drawn to the following places, which may be of interest for search:

Arrangements of closures with protective outer cap-like covers or of two or more co-operating closures, the outer closure being a foil membrane	B65D 51/185
Closures with auxiliary containers for additional articles or materials	B65D 51/28
Rigid containers disposed one within the other	B65D 81/3216

B65D 51/248

{the closure being provided with transient audible or visual signaling means, e.g. for indicating dispensing, or other illuminating or acoustic devices, e.g. whistles ([B65D 55/026](#), [B65D 55/028](#) take precedence; for indicating incorrect storage [B65D 79/02](#))}

Definition statement

This place covers:

Illustrative example of subject matter classified in this group:

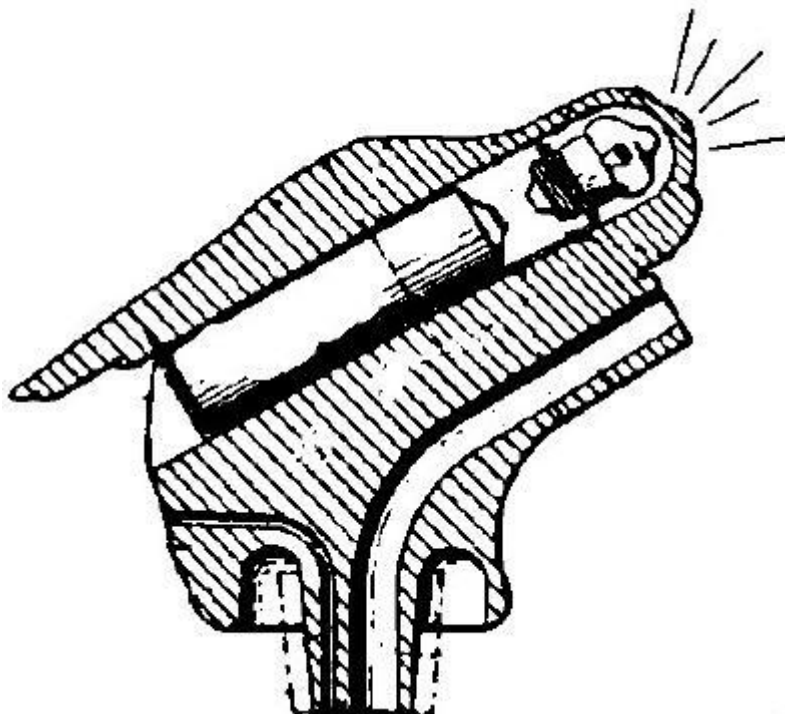

References

Limiting references

This place does not cover:

Initial opening or unauthorised access being indicated by a visual change using indicators other than tearable means	B65D 55/026
Initial opening or unauthorised access being indicated by the presence or absence of an audible or electrical signal	B65D 55/028

Informative references

Attention is drawn to the following places, which may be of interest for search:

Containers provided with an acoustic device, e.g. for indicating opening of the package	B65D 5/4291
Initial opening or unauthorised access being indicated by the presence or absence of an audible or electrical signal	B65D 55/028
For indicating incorrect storage	B65D 79/02

B65D 51/249

{the closure being specifically formed for supporting the container}

Definition statement

This place covers:

Illustrative example of subject matter classified in this group:

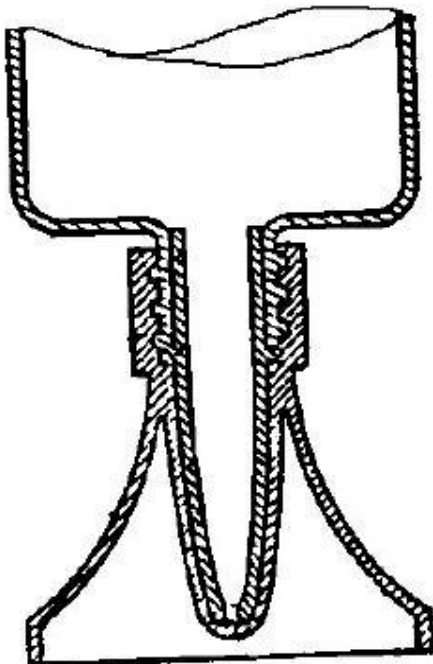
**References****Informative references**

Attention is drawn to the following places, which may be of interest for search:

Supporting means fixed to the container	B65D 23/001
Pliable tubular containers adapted to be permanently, deformed to expel contents with auxiliary devices, for applying contents to surfaces	B65D 35/36

B65D 51/26

with means for keeping contents in position, e.g. resilient means

Definition statement

This place covers:

Illustrative example of subject matter classified in this group:

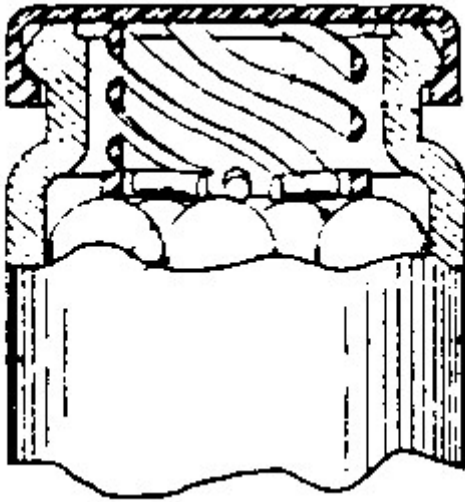

References

Limiting references

This place does not cover:

For keeping contents immersed in liquids	B65D 81/22
--	----------------------------

B65D 51/28

with auxiliary containers for additional articles or materials {(B65D 51/247 takes precedence)}

Definition statement

This place covers:

Illustrative example of subject matter classified in this group:

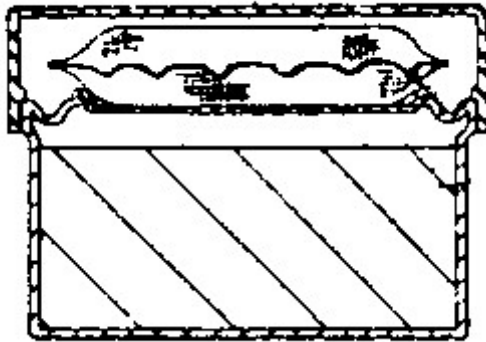
**References****Limiting references**

This place does not cover:

Closures located between an inner and an outer closure	B65D 51/247
--	-----------------------------

Informative references

Attention is drawn to the following places, which may be of interest for search:

Caps or cap-like covers without lines of weakness serving as, or incorporating, drinking or measuring vessels	B65D 41/26
Caps or cap-like covers with lines of weakness serving as, or incorporating, drinking or measuring vessels	B65D 41/56
Rigid containers disposed one within the other	B65D 81/3216

B65D 51/2807

{the closure presenting means for placing the additional articles or materials in contact with the main contents by acting on a part of the closure without removing the closure, e.g. by pushing down, pulling up, rotating or turning a part of the closure, or upon initial opening of the container}

References**Informative references**

Attention is drawn to the following places, which may be of interest for search:

Pliable tubular containers adapted to be permanently deformed to expel contents for mixing or discharging of two or more components	B65D 35/242
---	-----------------------------

Separate rigid or semi-rigid containers joined to each other at their external surfaces	B65D 81/3205
Rigid containers disposed one within the other with additional means facilitating admixture	B65D 81/3222

B65D 51/2814

{the additional article or materials being released by piercing, cutting or tearing an element enclosing it}

References

Informative references

Attention is drawn to the following places, which may be of interest for search:

Separate rigid or semi-rigid containers joined to each other at their external surfaces	B65D 81/3205
---	------------------------------

B65D 51/2821

{said element being a blister, a capsule or like sealed container}

Definition statement

This place covers:

Illustrative example of subject matter classified in this group:

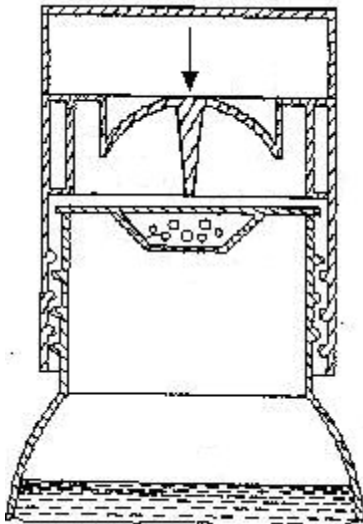

References

Limiting references

This place does not cover:

Details of blisters	B65D 75/32 , B65D 2575/32 , B65D 2575/36
---------------------	--

Informative references

Attention is drawn to the following places, which may be of interest for search:

Separate rigid or semi-rigid containers joined to each other at their external surfaces	B65D 81/3205
---	------------------------------

B65D 51/2828

{said element being a film or a foil ([B65D 51/2821](#), [B65D 51/2842](#) take precedence)}

Definition statement

This place covers:

Illustrative example of subject matter classified in this group:

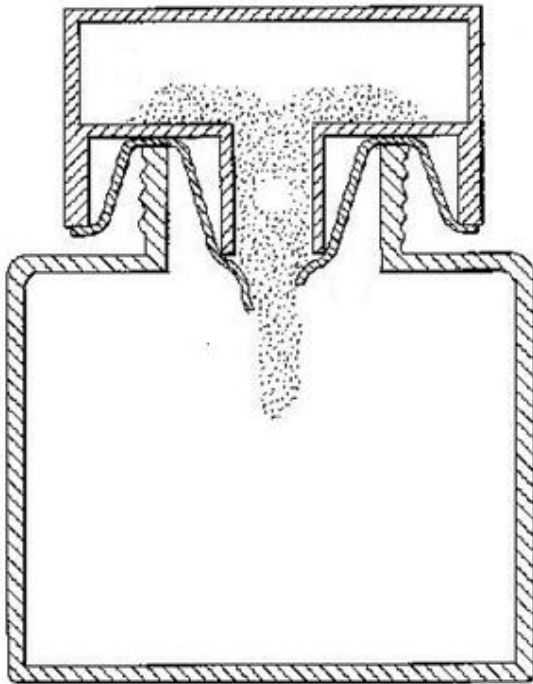
**References****Limiting references**

This place does not cover:

The additional article or materials being released by piercing, cutting or tearing an element enclosing it, said element being a blister, a capsule or like sealed container	B65D 51/2821
The additional article or materials being released by piercing, cutting or tearing an element enclosing it, said element being provided with a preformed weakened line	B65D 51/2842

Informative references

Attention is drawn to the following places, which may be of interest for search:

Separate rigid or semi-rigid containers joined to each other at their external surfaces	B65D 81/3205
---	------------------------------

B65D 51/2835

{ruptured by a sharp element, e.g. a cutter or a piercer}

Definition statement

This place covers:

Illustrative example of subject matter classified in this group:

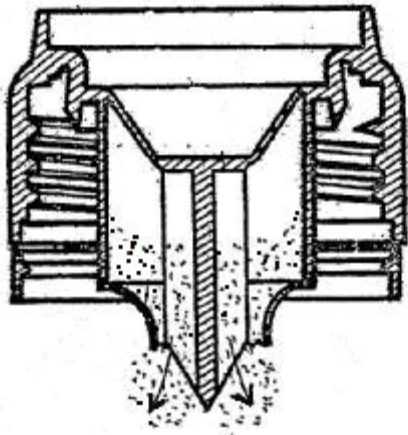
**References****Informative references**

Attention is drawn to the following places, which may be of interest for search:

Separate rigid or semi-rigid containers joined to each other at their external surfaces	B65D 81/3205
---	------------------------------

B65D 51/2842

{said element being provided with a preformed weakened line ([B65D 51/2821](#) takes precedence)}

Definition statement

This place covers:

Illustrative example of subject matter classified in this group:

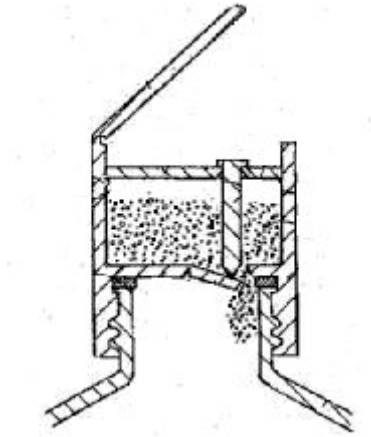
**References****Limiting references**

This place does not cover:

The additional article or materials being released by piercing, cutting or tearing an element enclosing it, said element being a blister, a capsule or like sealed container	B65D 51/2821
--	------------------------------

Informative references

Attention is drawn to the following places, which may be of interest for search:

Separate rigid or semi-rigid containers joined to each other at their external surfaces	B65D 81/3205
---	------------------------------

B65D 51/285

{ruptured by a sharp element, e.g. a cutter or a piercer}

Definition statement

This place covers:

Illustrative example of subject matter classified in this group:

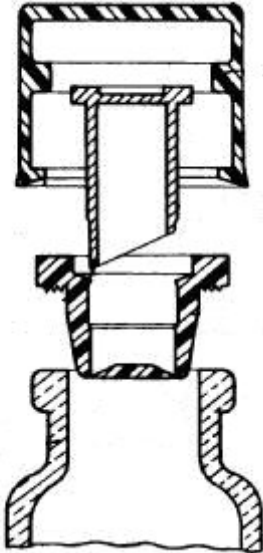
**References****Informative references**

Attention is drawn to the following places, which may be of interest for search:

Separate rigid or semi-rigid containers joined to each other at their external surfaces	B65D 81/3205
---	------------------------------

B65D 51/2857

{the additional article or materials being released by displacing or removing an element enclosing it ([B65D 51/2814](#) takes precedence)}

References**Limiting references**

This place does not cover:

The additional article or materials being released by piercing, cutting or tearing an element enclosing it	B65D 51/2814
--	------------------------------

Informative references

Attention is drawn to the following places, which may be of interest for search:

Separate rigid or semi-rigid containers joined to each other at their external surfaces	B65D 81/3205
---	------------------------------

B65D 51/2864

{the element being a plug or like element closing a passage between the auxiliary container and the main container}

Definition statement

This place covers:

Illustrative example of subject matter classified in this group:

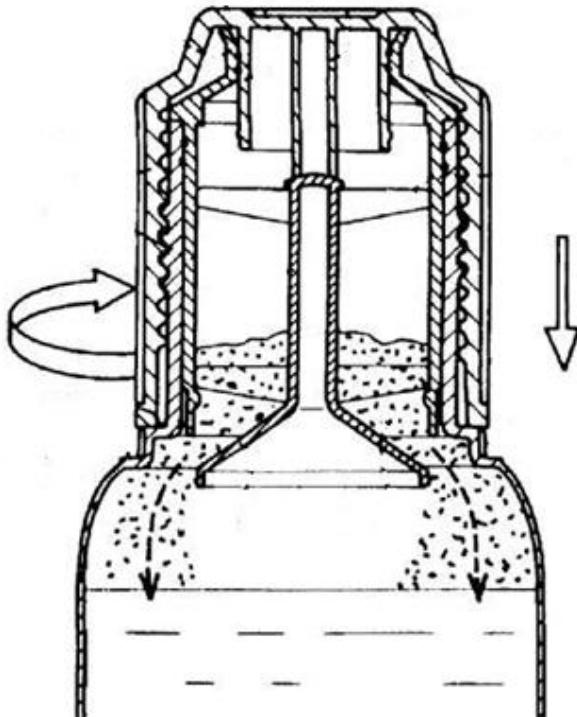
**References*****Informative references***

Attention is drawn to the following places, which may be of interest for search:

The partition being in the form of a plug or the like which can be raised off its seat by means of a pull cord or the like	B65D 25/087
Separate rigid or semi-rigid containers joined to each other at their external surfaces	B65D 81/3205

B65D 51/2871**{the plug falling into the main container}****Definition statement***This place covers:*

Illustrative example of subject matter classified in this group:

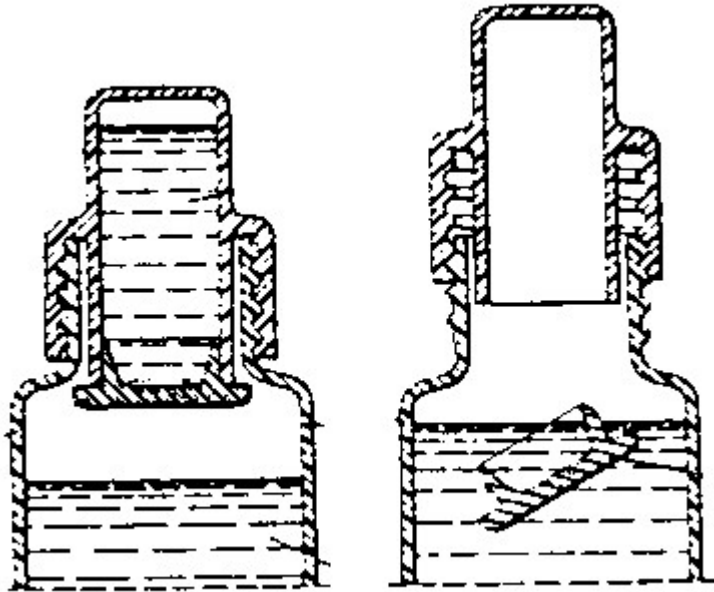
**References*****Informative references****Attention is drawn to the following places, which may be of interest for search:*

The partition being in the form of a plug or the like which is removed by increasing or decreasing the pressure within the container	B65D 25/082
The partition being in the form of a plug or the like which is dislodged by means of a plunger rod or the like pushing the plug down	B65D 25/085
Separate rigid or semi-rigid containers joined to each other at their external surfaces	B65D 81/3205

B65D 51/2878

{the element being a lid or cover seated on a passage between the auxiliary container and the main container}

Definition statement

This place covers:

Illustrative example of subject matter classified in this group:

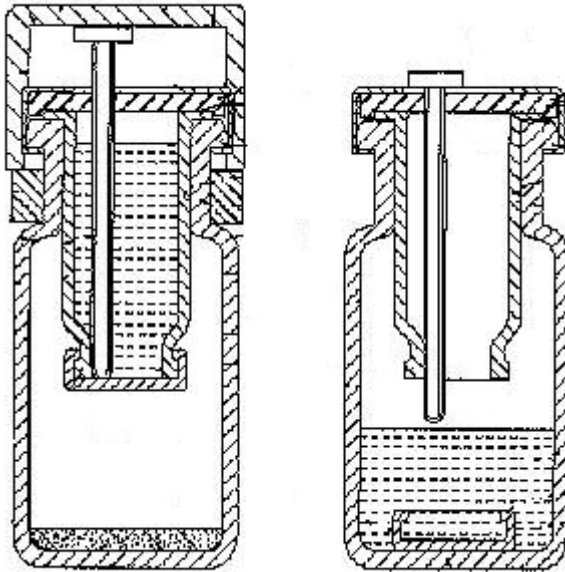
**References*****Informative references***

Attention is drawn to the following places, which may be of interest for search:

Partitions with provisions for removing or destroying	B65D 25/08
Separate rigid or semi-rigid containers joined to each other at their external surfaces	B65D 81/3205

B65D 51/2885

{the element being the auxiliary container falling into the main container;
the additional article or materials in solid block form falling into the main
container}

Definition statement

This place covers:

Illustrative example of subject matter classified in this group:

**References****Informative references**

Attention is drawn to the following places, which may be of interest for search:

Partitions with provisions for removing or destroying	B65D 25/08
Separate rigid or semi-rigid containers joined to each other at their external surfaces	B65D 81/3205

B65D 51/2892

{the element, e.g. a valve, opening an aperture of the auxiliary container
([B65D 51/2864](#), [B65D 51/2878](#) take precedence)}

Definition statement

This place covers:

Illustrative example of subject matter classified in this group:

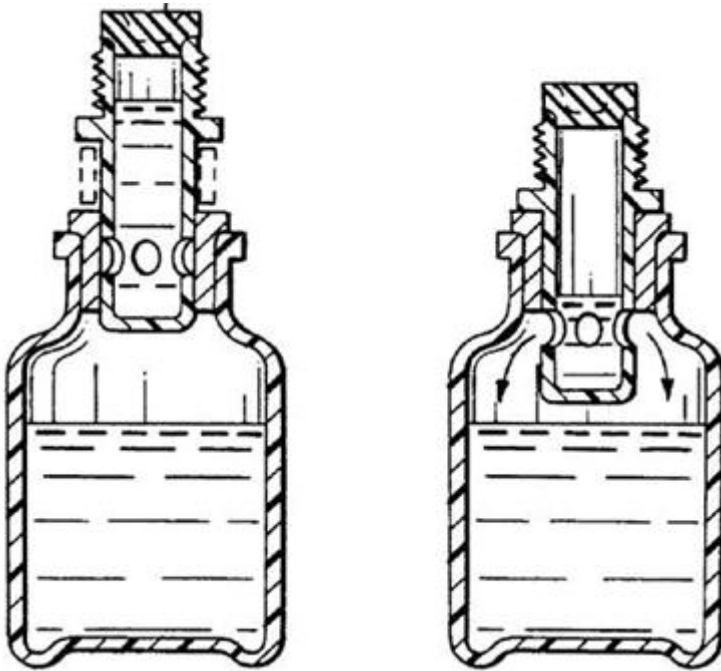
**References****Limiting references**

This place does not cover:

The additional article or materials being released by displacing or removing an element enclosing it, the element being a plug or like element closing a passage between the auxiliary container and the main container	B65D 51/2864
The additional article or materials being released by displacing or removing an element enclosing it, the element being a lid or cover seated on a passage between the auxiliary container and the main container	B65D 51/2878

Informative references

Attention is drawn to the following places, which may be of interest for search:

Separate rigid or semi-rigid containers joined to each other at their external surfaces	B65D 81/3205
---	------------------------------

B65D 51/30

for desiccators

Definition statement

This place covers:

Illustrative example of subject matter classified in this group:

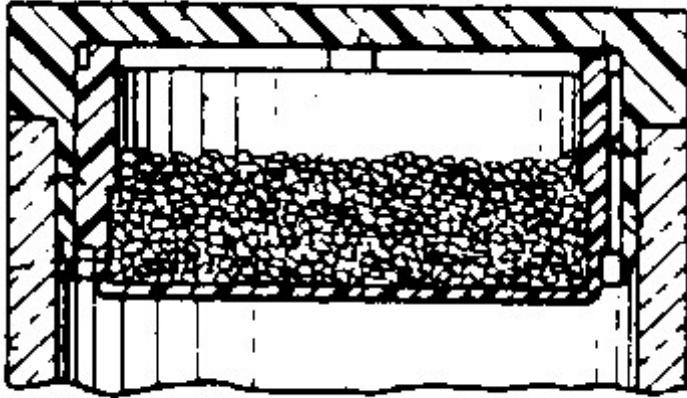

B65D 51/32

with brushes or rods for applying or stirring contents (droppers [B65D 47/18](#); {eating utensils or spatulas [B65D 51/246](#)})

Definition statement

This place covers:

Illustrative example of subject matter classified in this group:

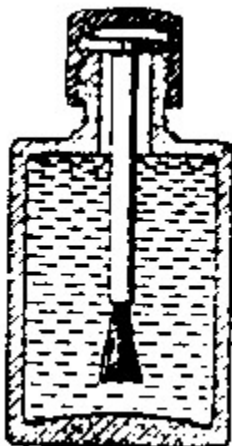

References

Limiting references

This place does not cover:

Brushes located on exterior of container which do not have to be removed from the container to apply the contents	B65D 47/42
Mixers	B65D 83/00

Informative references

Attention is drawn to the following places, which may be of interest for search:

Appliances specially adapted for applying liquid using a brush or the like	A45D 34/042
Appliances specially adapted for applying pasty paint using a brush or the like	A45D 40/262
Erasers, rubbers, or erasing devices with fluids	B43L 19/0018
Hand-held devices	B43M 11/06

B65D 53/00

Sealing or packing elements (sealings in general [F16J 15/00](#)); Sealings formed by liquid or plastics material

References

Informative references

Attention is drawn to the following places, which may be of interest for search:

Materials in mouldable or extrudable form for sealing or packing joints or covers	C09K 3/10
Sealings in general	F16J 15/00

Special rules of classification

Sealings or packing means combined with particular closures are classified with the closures, e.g. in subgroups of [B65D 39/00](#) together with indexing codes out of [B65D 2539/00](#), or in the groups [B65D 41/005](#), [B65D 41/0435](#).

B65D 53/02

Collars or rings

Definition statement

This place covers:

Illustrative example of subject matter classified in this group:

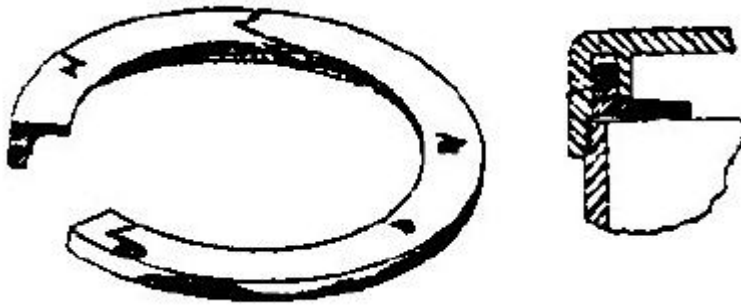

B65D 53/04

Discs

Definition statement

This place covers:

Illustrative example of subject matter classified in this group:

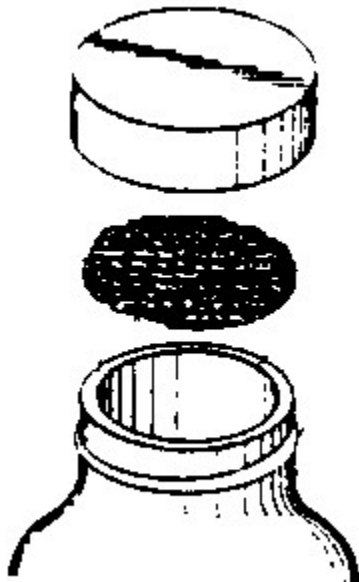

References

Informative references

Attention is drawn to the following places, which may be of interest for search:

Threaded or like caps or cap-like covers secured by rotation with separate sealing elements, discs	B65D 41/045
--	-----------------------------

B65D 53/06

Sealings formed by liquid or plastic material

Definition statement

This place covers:

Illustrative example of subject matter classified in this group:

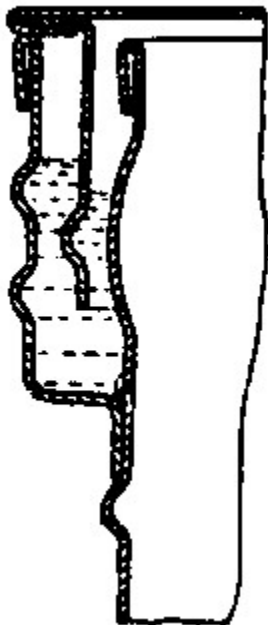

B65D 53/08

Flexible adhesive strips adapted to seal filling or discharging apertures

Definition statement

This place covers:

Adhesive strips or membranes that close an aperture and are totally removed to uncover the aperture are classified here.

Illustrative example of subject matter classified in this group:

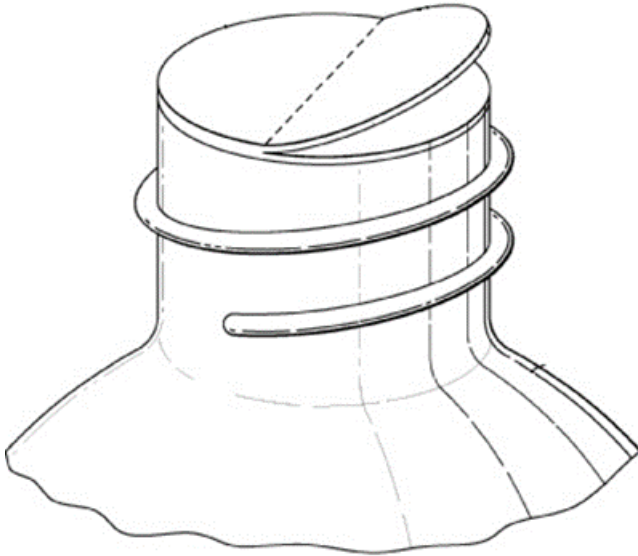

References

Informative references

Attention is drawn to the following places, which may be of interest for search:

Flexible tape or foil-like material	B65D 17/501
Deformable or tearable wires, strings, or strips	B65D 55/06

B65D 55/02

Locking devices; Means for discouraging or indicating unauthorised opening or removal of closure ({[B65D 41/32](#) takes precedence;} protective covers for bottles [B65D 23/08](#); protective cap-like outer covers for bottle or jar closures [B65D 41/62](#); pressure-applying means [B65D 45/00](#); closures with means for discouraging unauthorised opening or removal of closures [B65D 50/00](#))

References

Limiting references

This place does not cover:

Caps or cap-like covers with lines of weakness, tearing-strips, tags, or like opening or removal devices	B65D 41/32
--	----------------------------

Special rules of classification

The use of available Indexing Codes is mandatory.

B65D 55/022

{with ratchet effect between relatively rotating parts ([B65D 41/3404](#), [B65D 50/04](#) take precedence)}

Definition statement

This place covers:

Illustrative example of subject matter classified in this group:

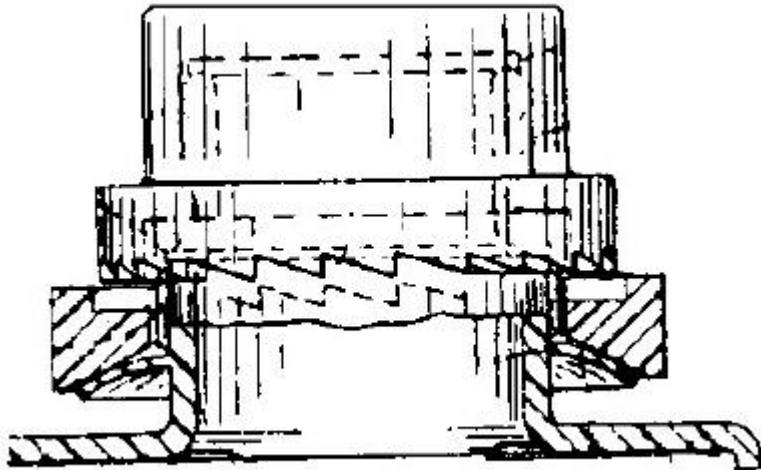
**References****Limiting references**

This place does not cover:

Threaded or like caps or cap-like covers with ratchet-and-pawl mechanism between the container and the closure skirt or the tamper element	B65D 41/3404
Closures with means for discouraging unauthorised opening or removal thereof, with or without indicating means requiring the combination of simultaneous actions	B65D 50/04

Special rules of classification

The use of available Indexing Codes is mandatory.

B65D 55/024

{Closures in which a part has to be ruptured to gain access to the contents
([B65D 41/32](#), [B65D 43/0235](#), [B65D 55/022](#), [B65D 55/06](#) take precedence)}

Definition statement

This place covers:

Illustrative example of subject matter classified in this group:

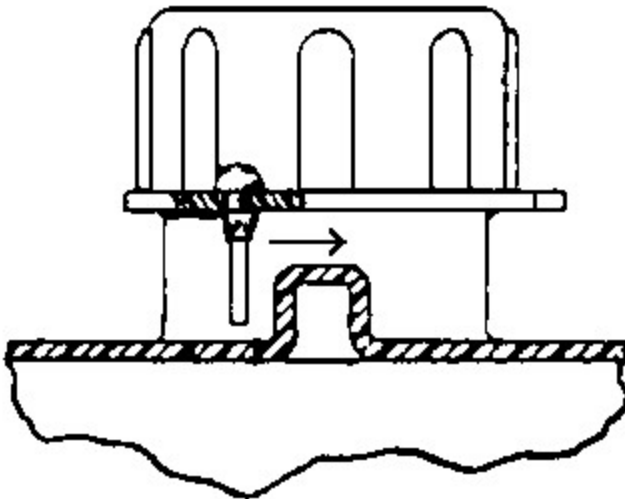
**References****Limiting references**

This place does not cover:

Caps or cap-like covers with lines of weakness, tearing-strips, tags, or like opening or removal devices	B65D 41/32
Removable lids or covers with integral tamper element	B65D 43/0235
Closures requiring the combination of different actions in succession	B65D 50/06
Locking devices with ratchet effect between relatively rotating parts	B65D 55/022

Informative references

Attention is drawn to the following places, which may be of interest for search:

Tearable part of the closure	B65D 2401/15
------------------------------	------------------------------

B65D 55/026

{initial opening or unauthorised access being indicated by a visual change using indicators other than tearable means, e.g. change of colour, pattern or opacity ([B65D 55/066](#) takes precedence)}

Definition statement

This place covers:

Illustrative example of subject matter classified in this group:

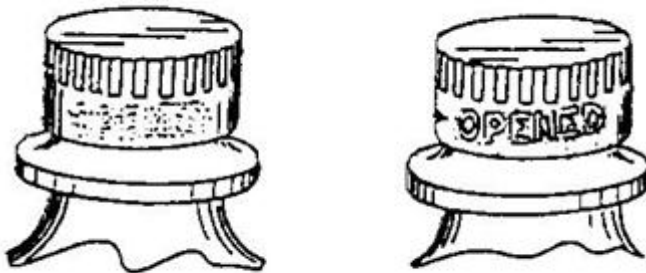
**References****Limiting references**

This place does not cover:

Foil covers combined with outer closures and comprising interacting or interposed tamper indicating means visible through the outer closure	B65D 55/066
---	-----------------------------

Informative references

Attention is drawn to the following places, which may be of interest for search:

Closures with special means for indicating unauthorised opening	B65D 27/30
End- or aperture-closing arrangements or devices, with special means for indicating unauthorised opening	B65D 33/34
Foil covers combined with outer closures and comprising interacting or interposed tamper indicating means visible through the outer closure	B65D 55/066

B65D 55/028

{initial opening or unauthorised access being indicated by the presence or absence of an audible or electrical signal}

References**Informative references**

Attention is drawn to the following places, which may be of interest for search:

Containers provided with an acoustic device	B65D 5/4291
---	-----------------------------

Closure being provided with transient audible or visual signaling means	B65D 51/248
Anti-theft means	B65D 2211/00

B65D 55/04

Spring clips, e.g. of wire or of sheet metal

Definition statement

This place covers:

Illustrative example of subject matter classified in this group:

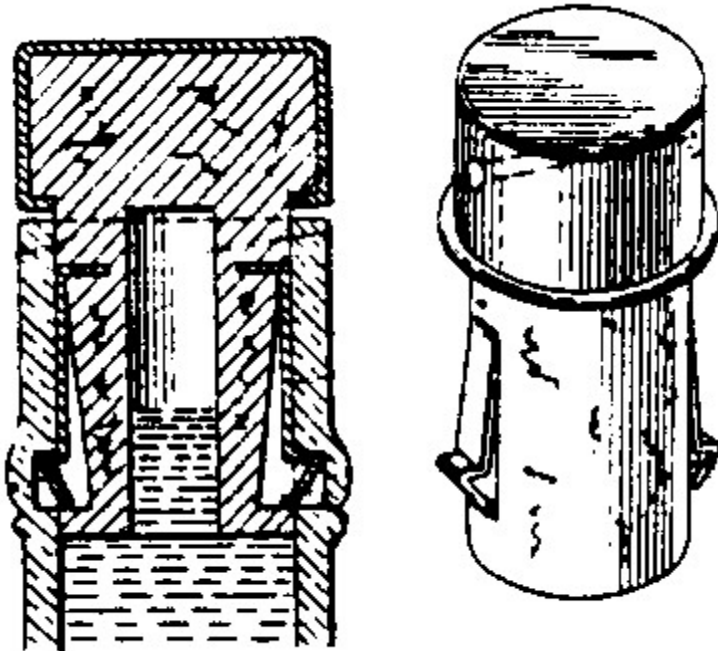

B65D 55/06

Deformable or tearable wires, strings, or strips (containers specially constructed to be opened by tear-strips, strings or the like [B65D 17/00](#); caps or cap-like closures with tear-strips [B65D 41/32](#)); Use of seals {, e.g. destructible locking pins ([B65D 55/022](#) takes precedence)}

Definition statement

This place covers:

Illustrative example of subject matter classified in this group:

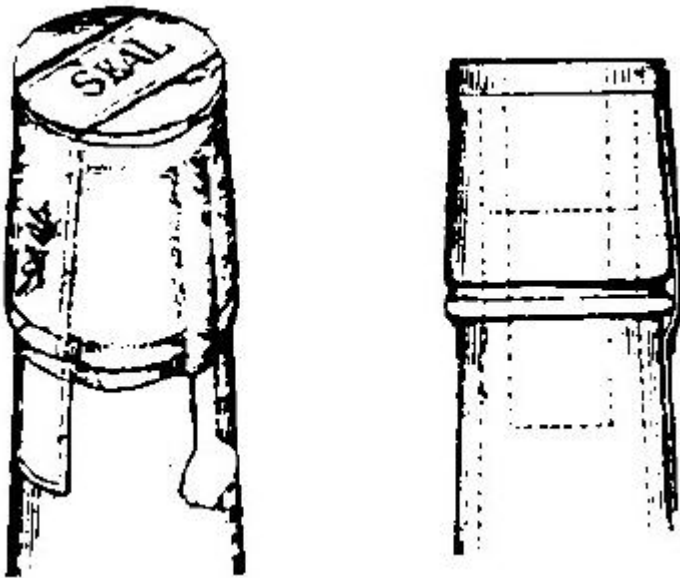

References

Limiting references

This place does not cover:

Locking devices with ratchet effect between relatively rotating parts	B65D 55/022
Non-destructible locking pins	B65D 55/10
Use of seals	B65D 2255/06

Informative references

Attention is drawn to the following places, which may be of interest for search:

Flexible adhesive strips adapted to seal filling or discharging apertures	B65D 53/08
Destructible or permanently removable bands	B65D 55/0818
Seals per se	G09F 3/00

B65D 55/063

{Muzzlets}

Definition statement

This place covers:

Illustrative example of subject matter classified in this group:

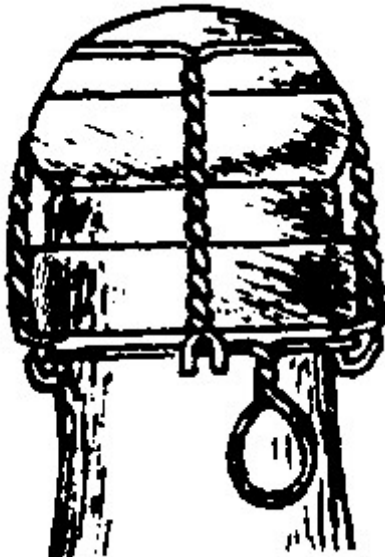

B65D 55/066

{Foil covers combined with outer closures and comprising interacting or interposed tamper indicating means visible through the outer closure, e.g. releasable coloured dyes, changeable patterns, pierceable membranes, visible through a transparent closure or through a window}

Definition statement

This place covers:

Illustrative example of subject matter classified in this group:

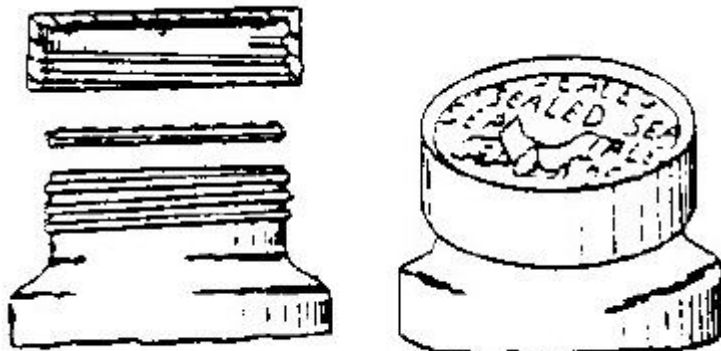

B65D 55/0809

{Destructible filamentary elements (non-destructible elements [B65D 45/322](#))}

Definition statement

This place covers:

Illustrative example of subject matter classified in this group:

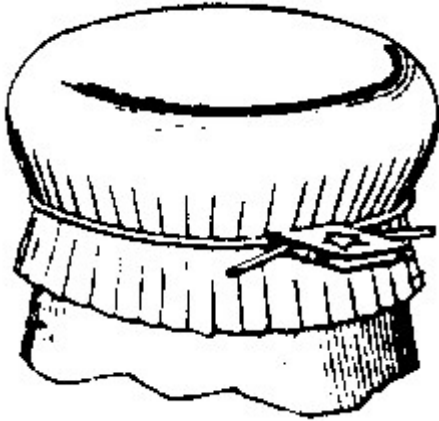

B65D 55/0818

{Destructible or permanently removable bands, e.g. adhesive}

Definition statement

This place covers:

Illustrative example of subject matter classified in this group:

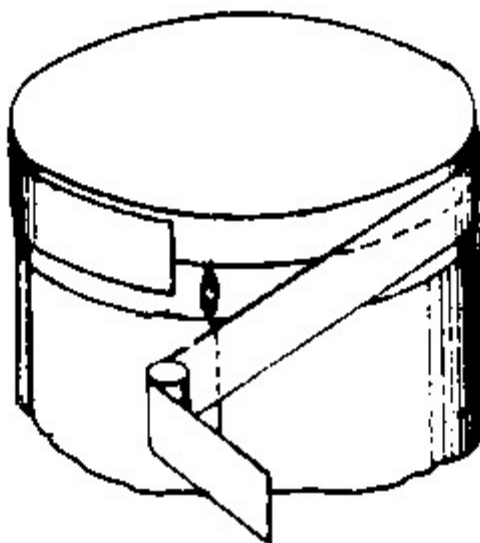

References

Limiting references

This place does not cover:

Seals made of paper	B65D 55/06
---------------------	----------------------------

Informative references

Attention is drawn to the following places, which may be of interest for search:

Tearing-strips or -wires	B65D 17/462
Tearing-strings or like flexible elements disposed beneath a wrapper, label, or other element of sheet material securing a lid, cover, or container mouth	B65D 77/36

B65D 55/0827

{Separate tamper bands inserted between container and closure ([B65D 41/32](#) takes precedence)}

Definition statement

This place covers:

Illustrative example of subject matter classified in this group:

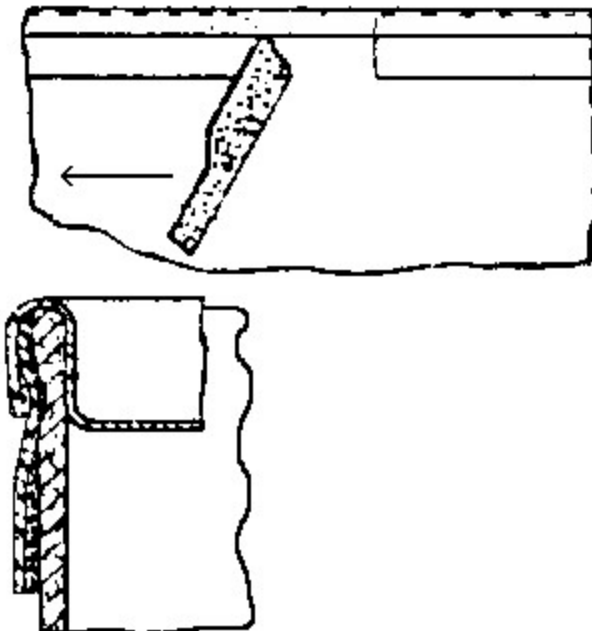

References

Limiting references

This place does not cover:

Caps or cap-like covers with lines of weakness, tearing-strips, tags, or like opening or removal devices	B65D 41/32
--	----------------------------

Informative references

Attention is drawn to the following places, which may be of interest for search:

Tearing-strips or -wires	B65D 17/462
--------------------------	-----------------------------

B65D 55/0836

{Metallic strips, e.g. soldered on container and lid (containers with integral tearing strips with tongues or tags for engagement by slotted keys [B65D 17/464](#))}

Definition statement

This place covers:

Illustrative example of subject matter classified in this group:

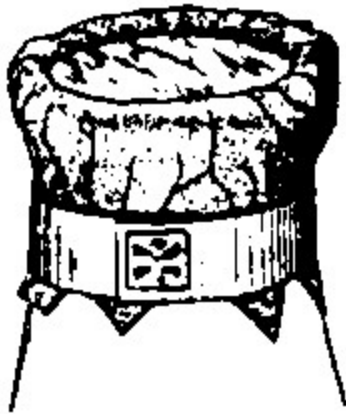
**B65D 55/0845**

{Metallic strips or cap-like collars having their edges crimped over part of the container and closure or other element, e.g. with C-shaped cross-section}

Definition statement

This place covers:

Illustrative example of subject matter classified in this group:

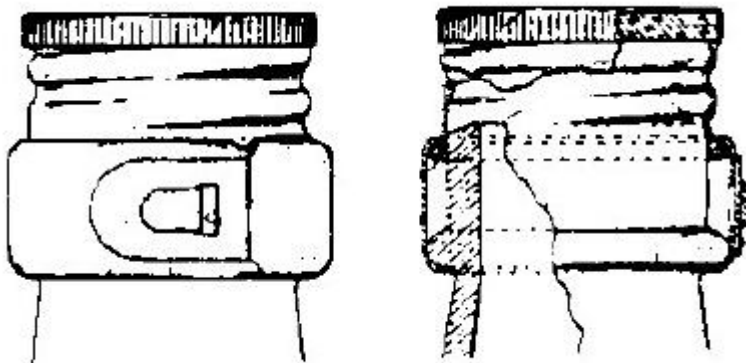

References

Informative references

Attention is drawn to the following places, which may be of interest for search:

Caps or cap-like covers adapted to be secured in position by permanent deformation of the wall-engaging parts made of metallic foil or like thin flexible material	B65D 41/44
Closures to be pierced by an extracting-device for the contents and fixed on the container by separate retaining means	B65D 51/002

B65D 55/0854

{Shrink-film bands ([B65D 41/54](#), [B65D 41/62](#) take precedence)}

Definition statement

This place covers:

Illustrative example of subject matter classified in this group:

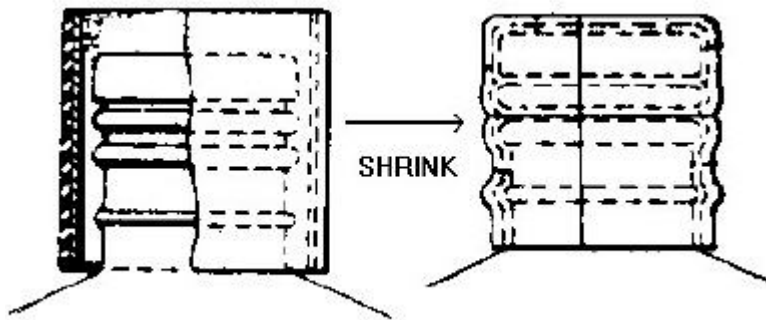

References

Limiting references

This place does not cover:

Caps or cap-like covers made of shrinkable material or formed in situ by dipping	B65D 41/54
Secondary protective cap-like outer covers for closure members	B65D 41/62

B65D 55/0863

{Plastic snap-on cap-like collars having frangible parts (collar for maintaining rigid discs in sealing engagement with mouth of containers [B65D 51/145](#))}

Definition statement

This place covers:

Illustrative example of subject matter classified in this group:

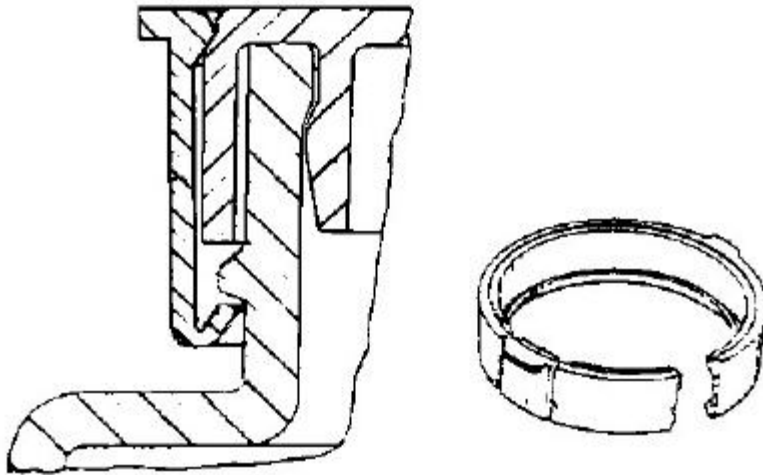
**B65D 55/0872**

{Destructible rigid elements snapping into annular grooves in closure for maintaining closure on container (non-destructible elements [B65D 45/322](#))}

Definition statement

This place covers:

Illustrative example of subject matter classified in this group:

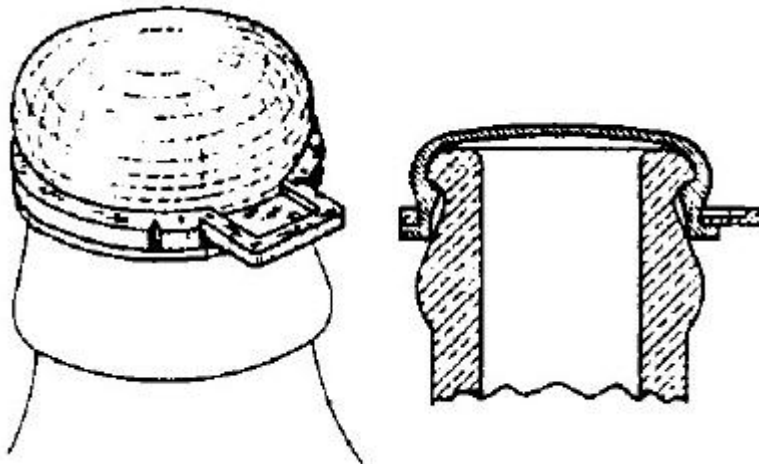

B65D 55/0881

{Closure not directly connected to container, but connected by means of a destructible intermediate ring ([B65D 55/0863](#) takes precedence)}

Definition statement

This place covers:

Illustrative example of subject matter classified in this group:

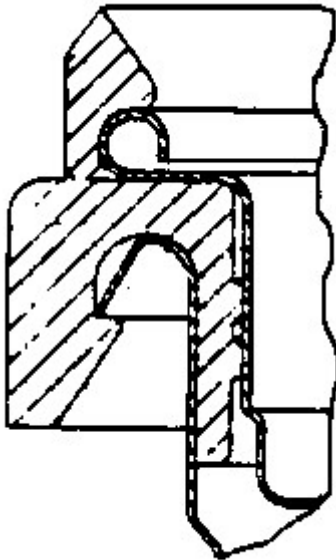
**References****Limiting references**

This place does not cover:

Plastic snap-on cap-like collars having frangible parts	B65D 55/0863
---	------------------------------

Informative references

Attention is drawn to the following places, which may be of interest for search:

Tearing-strips or -wires	B65D 17/462
--------------------------	-----------------------------

B65D 55/089

{Annular tamper band connected to the closure, but not coacting with the container for preventing initial downward motion, e.g. on two-parts child-proof closures ([B65D 41/32](#) takes precedence)}

Definition statement

This place covers:

Illustrative example of subject matter classified in this group:

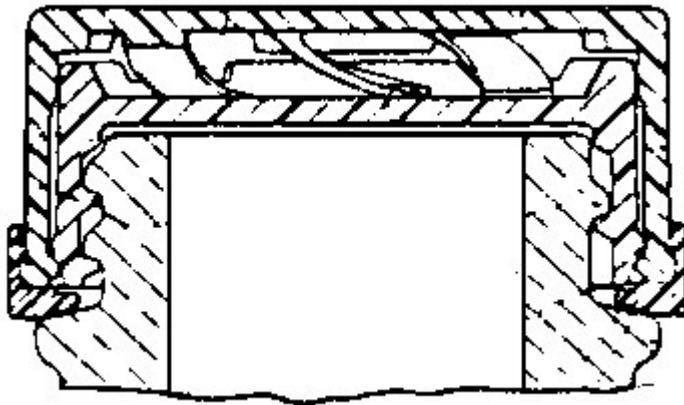
**References****Limiting references**

This place does not cover:

Caps or cap-like covers with lines of weakness, tearing-strips, tags, or like opening or removal devices	B65D 41/32
--	----------------------------

B65D 55/10

Locking pins {(destructible locking pins [B65D 55/06](#))}

Definition statement

This place covers:

Illustrative example of subject matter classified in this group:

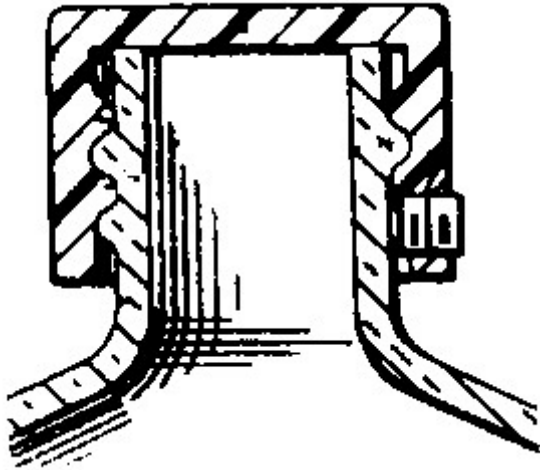

B65D 55/12

Devices or means with relatively-moving parts co-operating with abutments on bottle or jar {([B65D 55/022](#) takes precedence)}

Definition statement

This place covers:

Illustrative example of subject matter classified in this group:

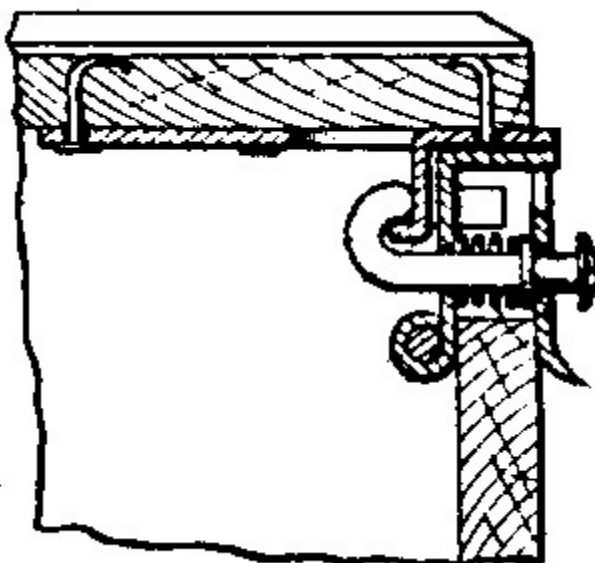

References

Limiting references

This place does not cover:

Locking devices with ratchet effect between relatively rotating parts	B65D 55/022
---	-----------------------------

B65D 55/14

Applications of locks, e.g. of permutation or key-controlled locks

Definition statement

This place covers:

Illustrative example of subject matter classified in this group:

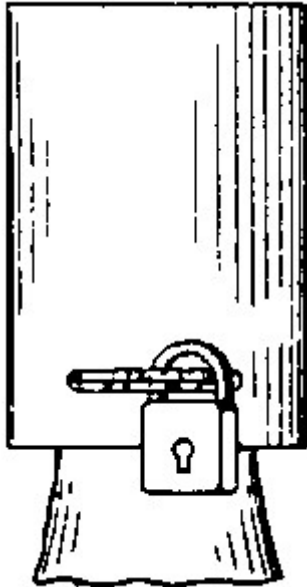

B65D 55/145

{of permutation locks}

Definition statement

This place covers:

Illustrative example of subject matter classified in this group:

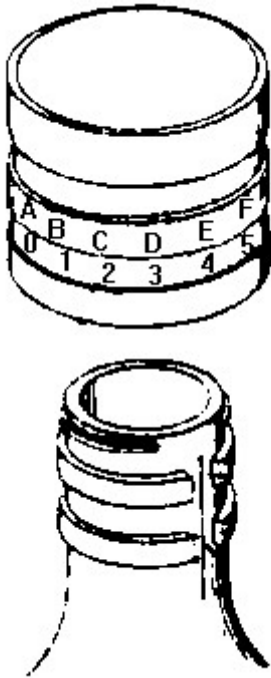

B65D 55/16**Devices preventing loss of removable closure members****Definition statement**

This place covers:

Illustrative example of subject matter classified in this group:

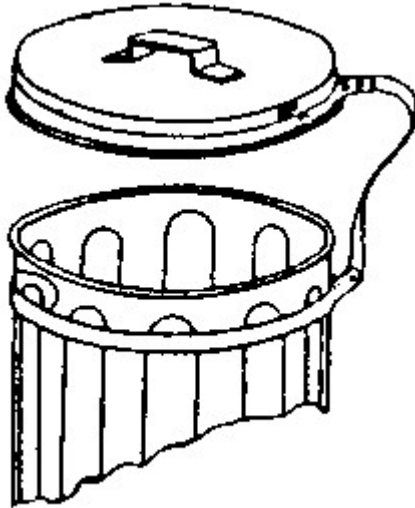
**References****Informative references**

Attention is drawn to the following places, which may be of interest for search:

Pliable tubular containers adapted to be permanently deformed to expel contents for preventing loss of removable closure members	B65D 35/42
Closures with discharging devices other than pumps and closure-retaining means	B65D 47/14

B65D 55/165

{by an element constrained within the container neck, i.e. the element passing through the container opening}

Definition statement

This place covers:

Illustrative example of subject matter classified in this group:

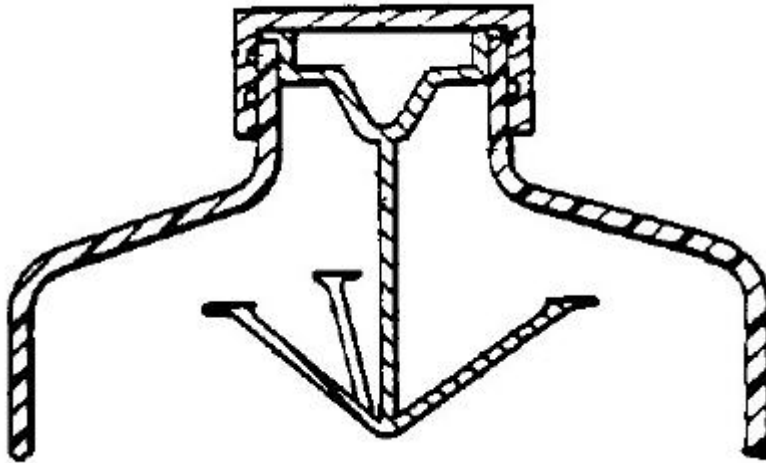
**B65D 57/00**

Internal frames or supports for flexible articles, e.g. stiffeners; Separators for articles packaged in stacks or groups, e.g. for preventing adhesion of sticky articles {(B65D 71/70 takes precedence)}

Definition statement

This place covers:

Illustrative example of subject matter classified in this group:

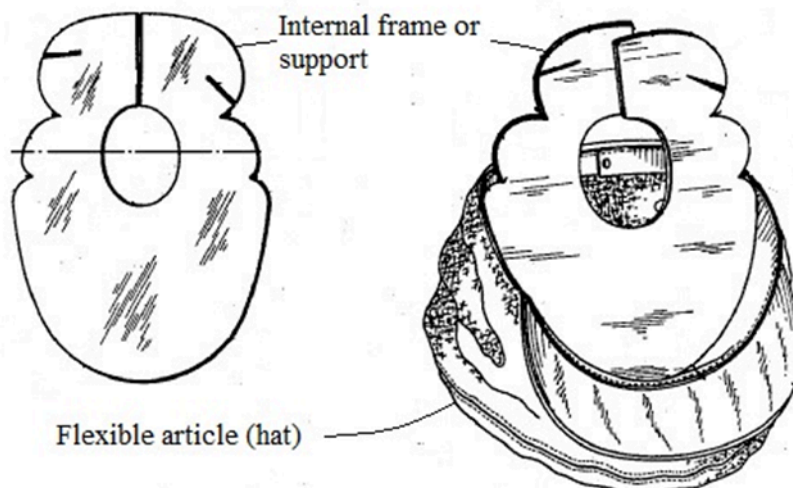

References

Limiting references

This place does not cover:

Trays provided with projections or recesses in order to assemble multiple articles	B65D 71/70
--	----------------------------

References out of a residual place

Examples of places in relation to which this place is residual:

Internal frames for bags	B65D 33/02
Spacers or 'stickers' for drying wood or similar material	F26B 25/18 , F26B 25/185

Informative references

Attention is drawn to the following places, which may be of interest for search:

Anti-slip separators compare with	B65D 33/005
Stack holders or separators	B65G 1/14

Special rules of classification

The internal frame or support is for a flexible object, e.g. hats, linens, clothing. In this group an object would not comprise a flexible package. Flexible packages with internal frames or supports are classified in [B65D 33/02](#) and exceptionally in the [B65D 75/52](#).

B65D 57/003

{for horizontally placed articles, i.e. for stacked or nested articles}

Definition statement

This place covers:

Illustrative example of subject matter classified in this group.

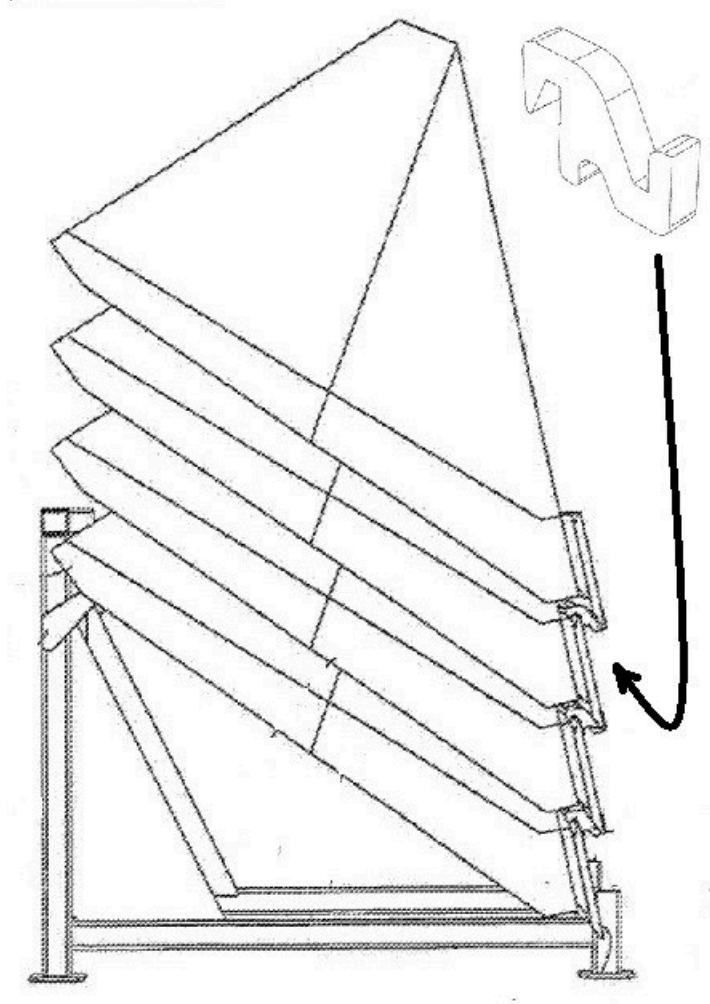
**References****Informative references**

Attention is drawn to the following places, which may be of interest for search:

Trays provided with projection or recesses in order to assemble multiple articles, e.g. intermediate elements for stacking	B65D 71/70
Spacers or "stickers" for drying wood or similar material	F26B 25/18

B65D 57/004

{the articles being substantially flat panels, e.g. wooden planks}

Definition statement

This place covers:

Illustrative example of subject matter classified in this group.

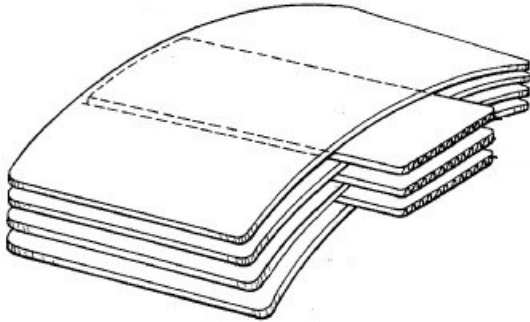

References

Informative references

Attention is drawn to the following places, which may be of interest for search:

Spacers or "stickers" for drying wood or similar material	F26B 25/18
---	----------------------------

B65D 57/005

{Separators for vertically placed articles}

Definition statement

This place covers:

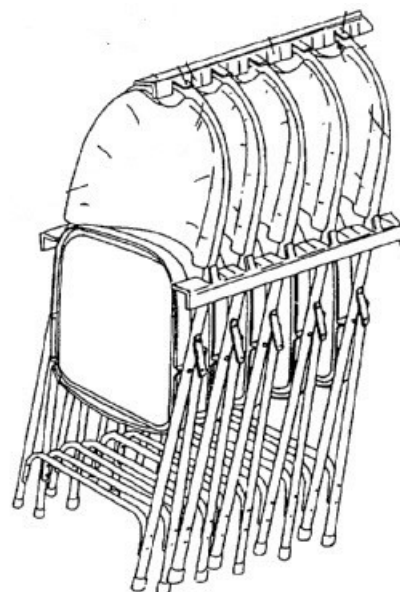

Illustrative example of subject matter classified in this group.

B65D 57/006

{the articles being substantially flat panels, e.g. wooden planks or photovoltaic panels}

Definition statement

This place covers:

Illustrative example of subject matter classified in this group.

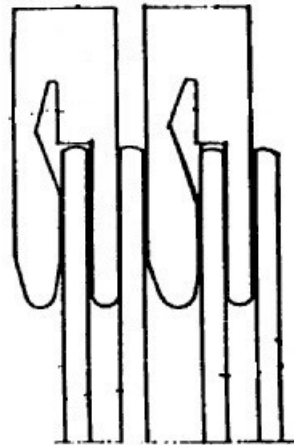
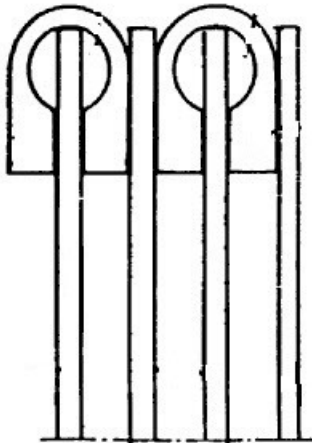

B65D 59/02

Plugs

Definition statement

This place covers:

Illustrative example of subject matter classified in this group:

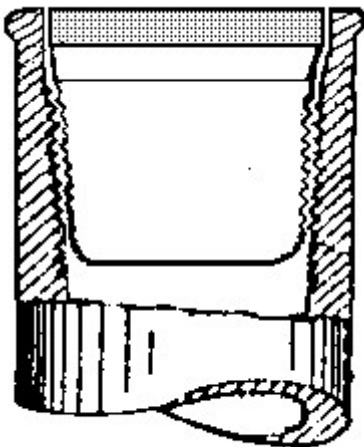

B65D 59/04**Sleeves, e.g. postal tubes****Definition statement**

This place covers:

Illustrative example of subject matter classified in this group:

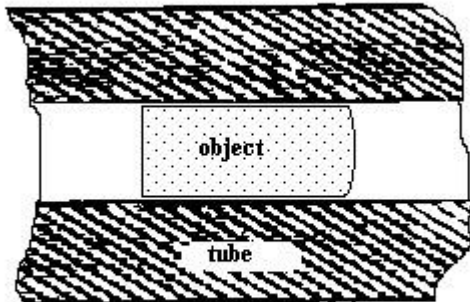
**References****Limiting references**

This place does not cover:

Tube-like magazines for electric components	H05K 13/0084
---	------------------------------

Informative references

Attention is drawn to the following places, which may be of interest for search:

Containers of polygonal cross-section with end closures formed by inward-folding of self-locking flaps hinged to tubular body	B65D 5/10
Integral elements for containers having tubular body walls formed by folding inwardly of extensions hinged to the upper or lower edges of the body	B65D 5/5011

B65D 59/06

Caps

Definition statement

This place covers:

Illustrative example of subject matter classified in this group:

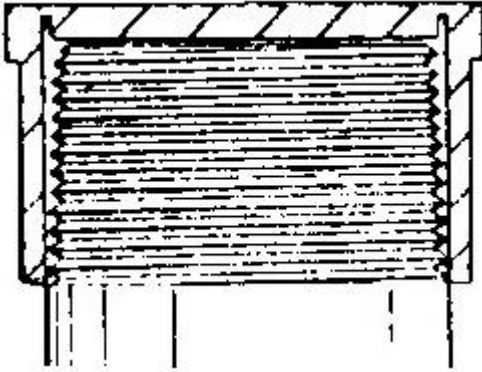

B65D 59/08

of polygonal cross-section

Definition statement

This place covers:

Illustrative example of subject matter classified in this group:

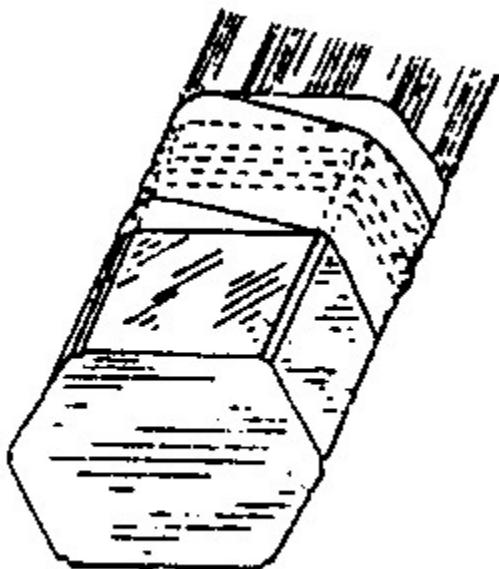

B65D 61/00

External frames or supports adapted to be assembled around, or applied to, articles (collapsible containers [B65D 5/00](#), [B65D 7/24](#), [B65D 9/12](#), [B65D 11/18](#))

Definition statement

This place covers:

Illustrative example of subject matter classified in this group:

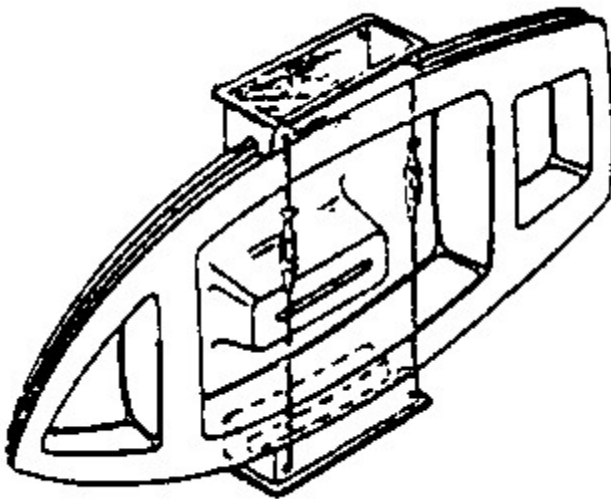

References

Limiting references

This place does not cover:

External frames for bags	B65D 33/02
Holders or wrappers as eating aids for fast food, e.g. hamburgers,	A47G 21/001

B65D 63/00

Flexible elongated elements, e.g. straps, for bundling or supporting articles {{attached to or integral with bags or sacks [B65D 33/165](#); for securing load [B60P 7/0823](#)}}

References

Limiting references

This place does not cover:

Decorative rosettes or ribbons	B65D 67/00
Devices for clamping the clamping element	B23P
Tighteners for straps	B60P 7/0823
Circlips	F16B

Informative references

Attention is drawn to the following places, which may be of interest for search:

Buttons, pins, buckles, slide fasteners, or the like	A44B
Cranes; Load-engaging elements or devices for cranes, capstans, winches, or tackles	B66C

B65D 63/04**Joints produced by deformation of ends of elements****Definition statement**

This place covers:

Illustrative example of subject matter classified in this group:

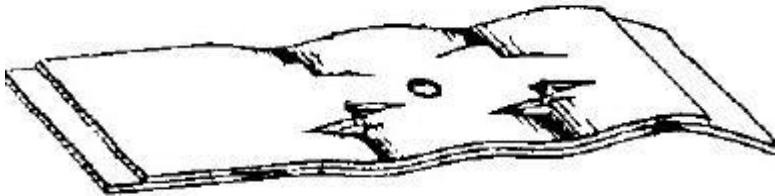
**B65D 63/06****Joints produced by application of separate securing members, e.g. by deformation thereof****Definition statement**

This place covers:

Illustrative example of subject matter classified in this group:

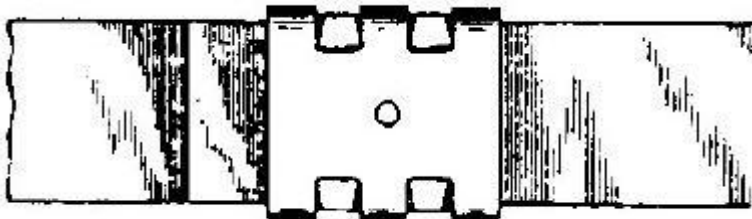
**References****Limiting references**

This place does not cover:

For non-metallic straps	B65D 63/14
Tensioning straps for securing loads	B60P 7/0823

B65D 63/08

Joints using buckles, wedges, or like locking members attached to the ends of the elements

Definition statement

This place covers:

Illustrative example of subject matter classified in this group:

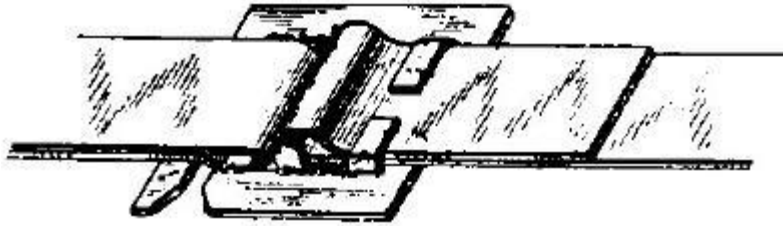
**B65D 63/10**

Non-metallic straps, tapes, or bands; Filamentary elements, e.g. strings, threads or wires; Joints between ends thereof

References**Limiting references**

This place does not cover:

Flexible bands	F16L 3/137 , F16L 3/233
----------------	---

Special rules of classification

The use of available Indexing Codes is mandatory.

B65D 63/1009**{Adhesive tapes}****Definition statement***This place covers:*

Illustrative example of subject matter classified in this group:

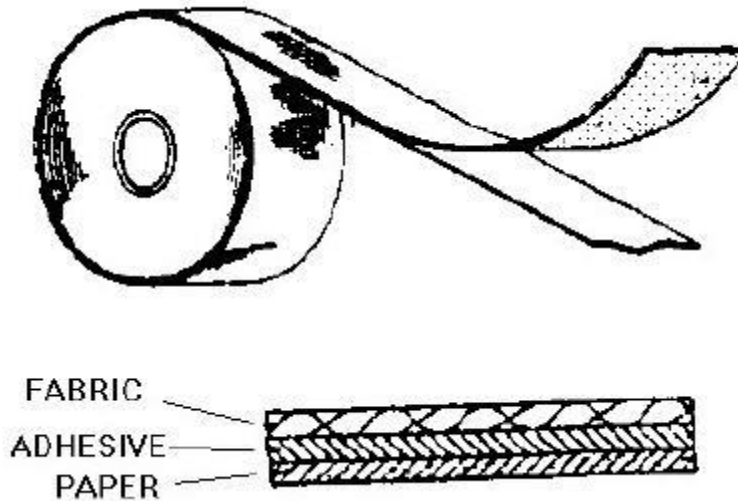
**References****Informative references***Attention is drawn to the following places, which may be of interest for search:*

With end closures formed by inward folding of flaps and securing them by adhesive tapes, labels or the like; for decoration purposes	B65D 5/0236
Destructible or permanently removable bands	B65D 55/0818
Packaging elements adhered to the articles	B65D 71/0085
Double sided adhesive tape	B65D 2313/08

Special rules of classification

The use of available Indexing Codes is mandatory.

B65D 63/1018

{Joints produced by application of integral securing members, e.g. buckles, wedges, tongue and slot, locking head and teeth or the like}

Definition statement

This place covers:

Illustrative example of subject matter classified in this group:

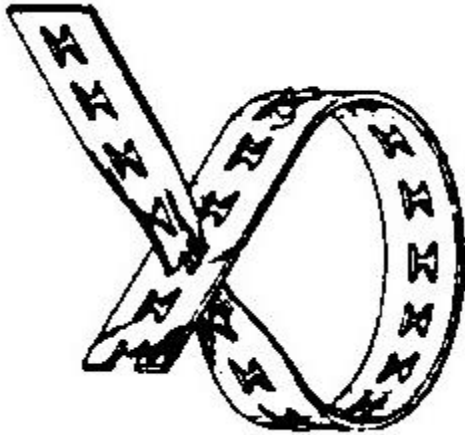
**References****Limiting references**

This place does not cover:

Tools for applying bundling straps and bundling strap bandoliers	B65B 13/027
For flexible bands	F16L 3/233 , F16L 3/137 , H02G 3/26

Special rules of classification

The use of available Indexing Codes is mandatory.

B65D 63/1027

{the integral securing member being formed as a female and male locking member, e.g. locking head and locking teeth, or the like}

Definition statement

This place covers:

Illustrative example of subject matter classified in this group:

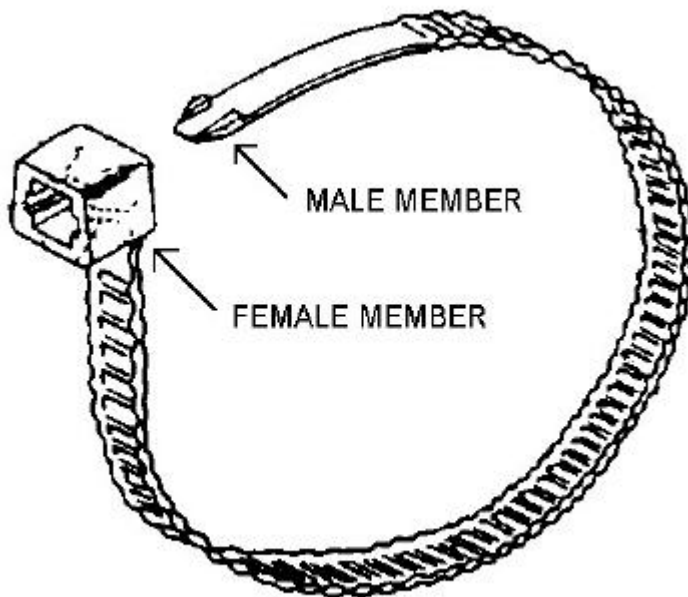

References

Limiting references

This place does not cover:

Cable tie bandoliers for use with automatic tools	B65B 13/027
---	-----------------------------

Special rules of classification

The use of available Indexing Codes is mandatory.

B65D 63/1036

{the female locking member being provided with at least one metal barb}

Definition statement

This place covers:

Illustrative example of subject matter classified in this group:

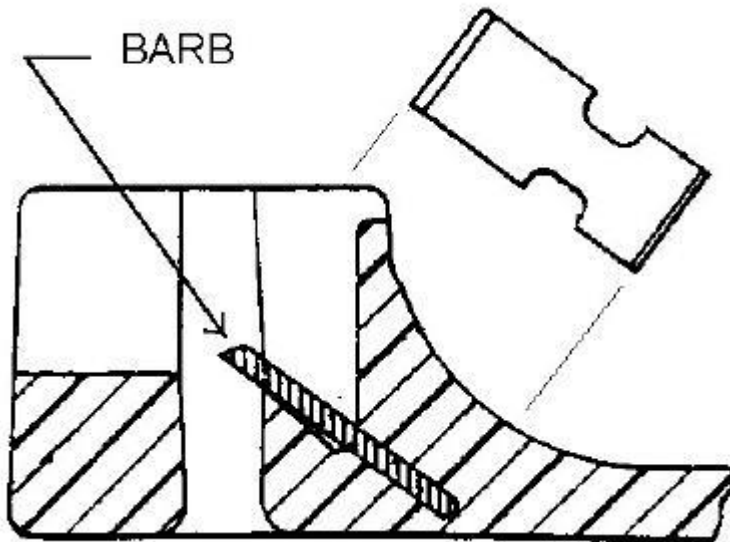

Special rules of classification

The use of available Indexing Codes is mandatory.

B65D 63/1063

{the female locking member being provided with at least one plastic barb}

Definition statement

This place covers:

Illustrative example of subject matter classified in this group:

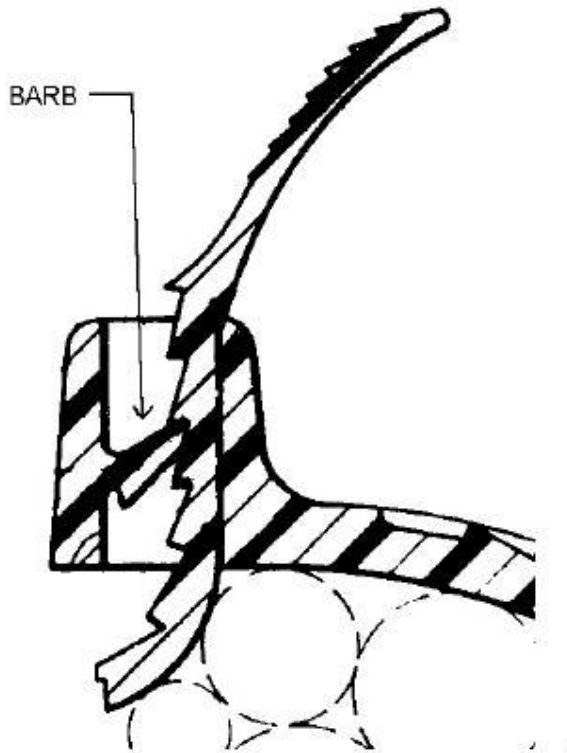

Special rules of classification

The use of available Indexing Codes is mandatory.

B65D 63/1072

{the barb having a plurality of serrations}

Definition statement

This place covers:

Illustrative example of subject matter classified in this group:

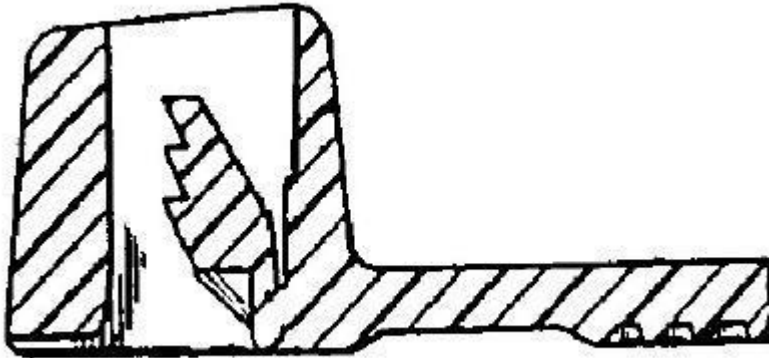

Special rules of classification

The use of available Indexing Codes is mandatory.

B65D 63/1081

{with barbs situated on opposite sides of, or concentrically in, the female locking member}

Definition statement

This place covers:

Illustrative example of subject matter classified in this group:

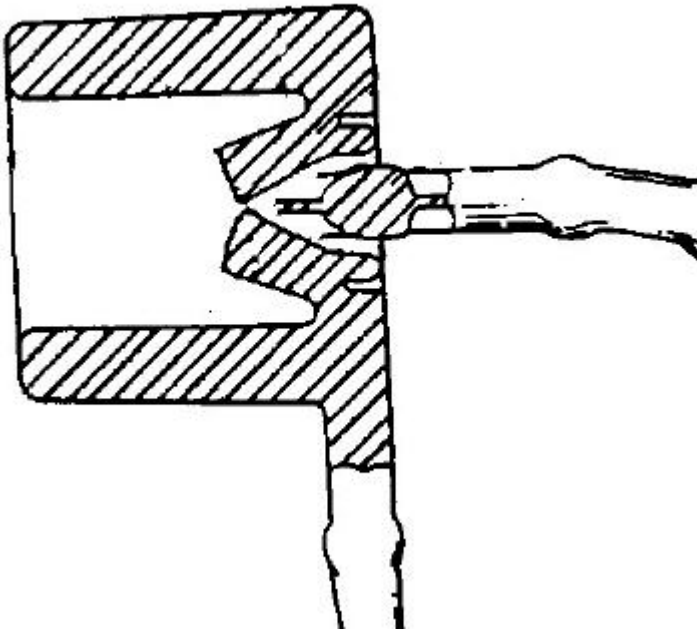

Special rules of classification

The use of available Indexing Codes is mandatory.

B65D 63/109

{Application of elastics or like elements}

Definition statement

This place covers:

Illustrative example of subject matter classified in this group:

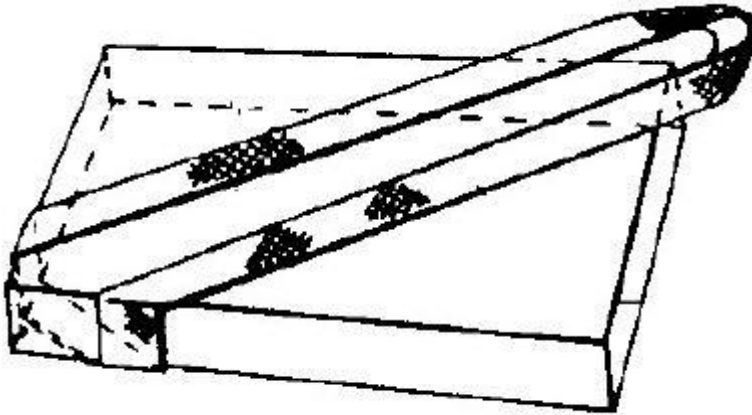

Special rules of classification

The use of available Indexing Codes is mandatory.

B65D 63/12

Joints produced by deformation or tying of ends of elements

Definition statement

This place covers:

Illustrative example of subject matter classified in this group:

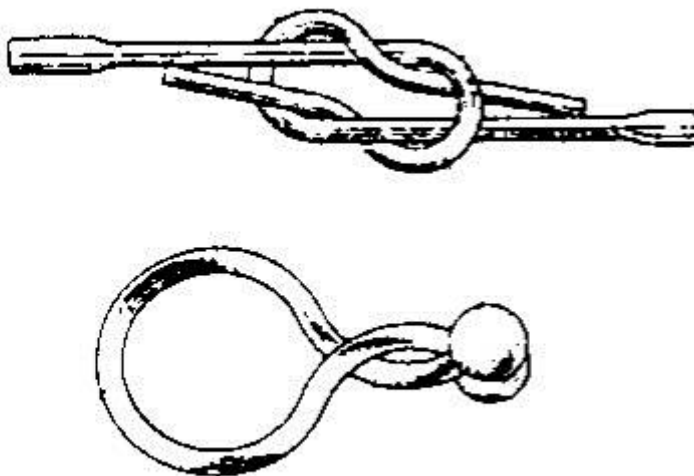

Special rules of classification

The use of available Indexing Codes is mandatory.

B65D 63/14**Joints produced by application of separate securing members****Definition statement**

This place covers:

Illustrative example of subject matter classified in this group:

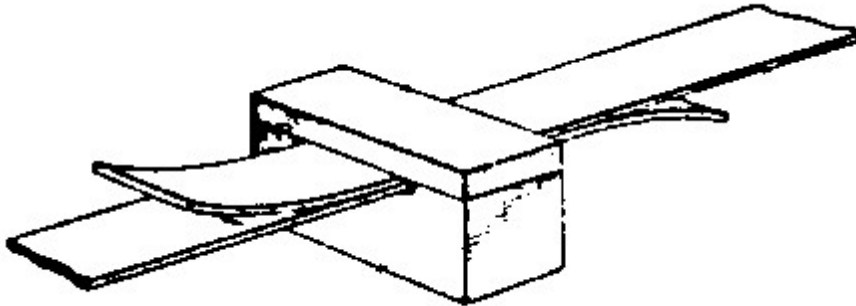
**References****Limiting references**

This place does not cover:

For clamps made of metal	B65D 33/1641
For metallic straps	B65D 63/06
Tensioning straps for securing loads	B60P 7/0823

Special rules of classification

The use of available Indexing Codes is mandatory.

B65D 63/16

Joints using buckles, wedges, or like locking members attached to the end of the element

Definition statement

This place covers:

Illustrative example of subject matter classified in this group:

**Special rules of classification**

The use of available Indexing Codes is mandatory.

B65D 63/18

Elements provided with handles or other suspension means

Definition statement

This place covers:

Illustrative example of subject matter classified in this group:

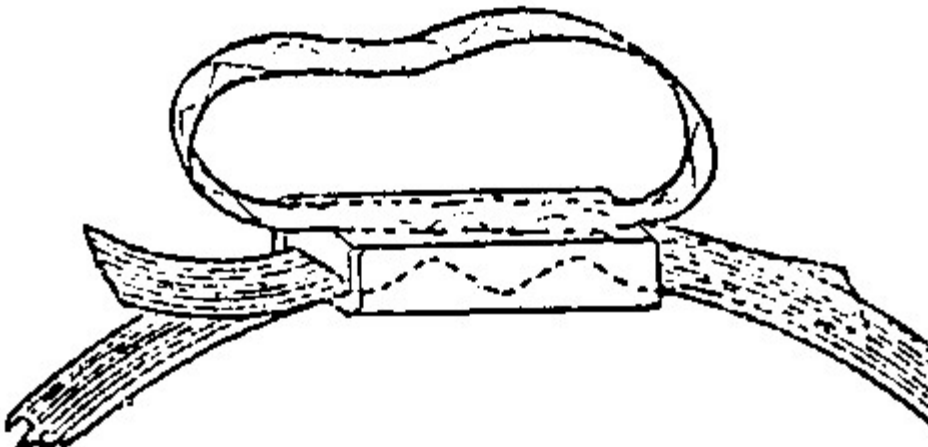
**References****Limiting references**

This place does not cover:

Loose handles for carrying purposes	A45F 5/10
-------------------------------------	---------------------------

Slings	B66C
--------	----------------------

B65D 65/04

non-rectangular

References

Limiting references

This place does not cover:

Holders or wrappers as eating aids for fast food, e.g. hamburgers	A47G 21/001
---	-----------------------------

Informative references

Attention is drawn to the following places, which may be of interest for search:

Layered products per se	B32B
-------------------------	----------------------

B65D 65/06

formed with foldable flaps, e.g. interlocking flaps

Special rules of classification

The use of available Indexing Codes is mandatory.

B65D 65/08

with fastening elements, e.g. slide fasteners

Definition statement

This place covers:

Illustrative example of subject matter classified in this group:

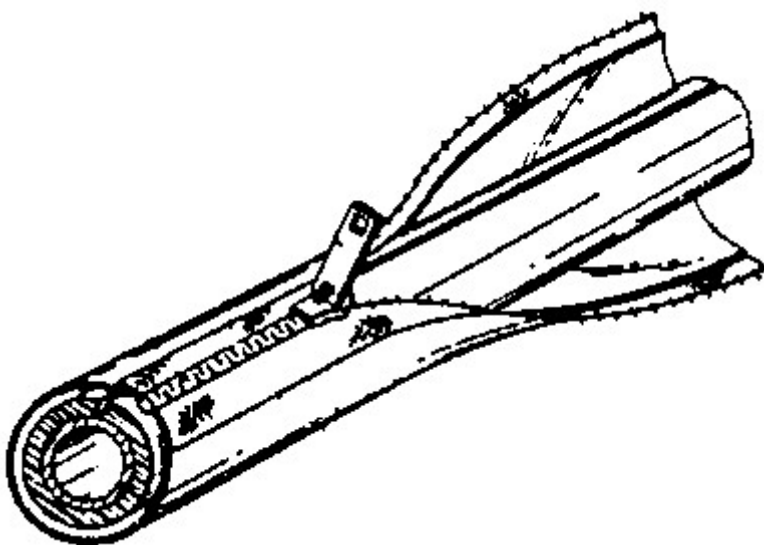

B65D 65/14

with areas coated with adhesive

Definition statement

This place covers:

Illustrative example of subject matter classified in this group:

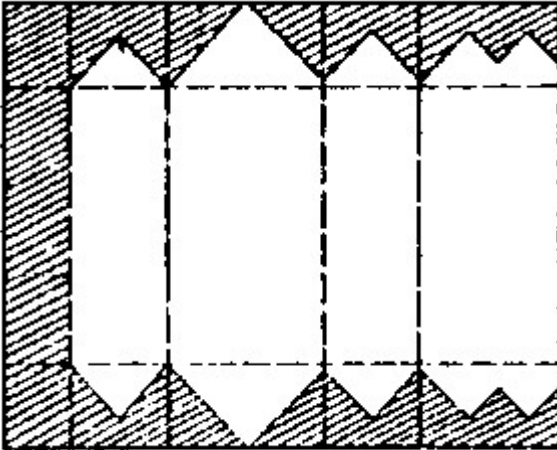

Special rules of classification

The use of available Indexing Codes is mandatory.

B65D 65/18

with some areas transparent and others opaque

Definition statement

This place covers:

Illustrative example of subject matter classified in this group:

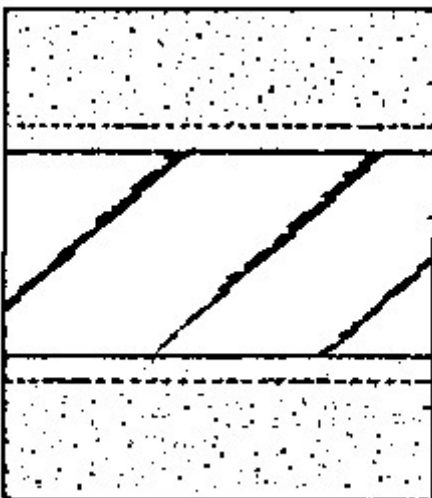

References

Informative references

Attention is drawn to the following places, which may be of interest for search:

Windows or other apertures	B65D 33/04
Inspection openings and windows	B65D 75/522

B65D 65/22

Details

References

Limiting references

This place does not cover:

Opening devices	B65D 75/58
-----------------	----------------------------

B65D 65/24

Tabs or other projections for locating contents

Definition statement

This place covers:

Illustrative example of subject matter classified in this group:

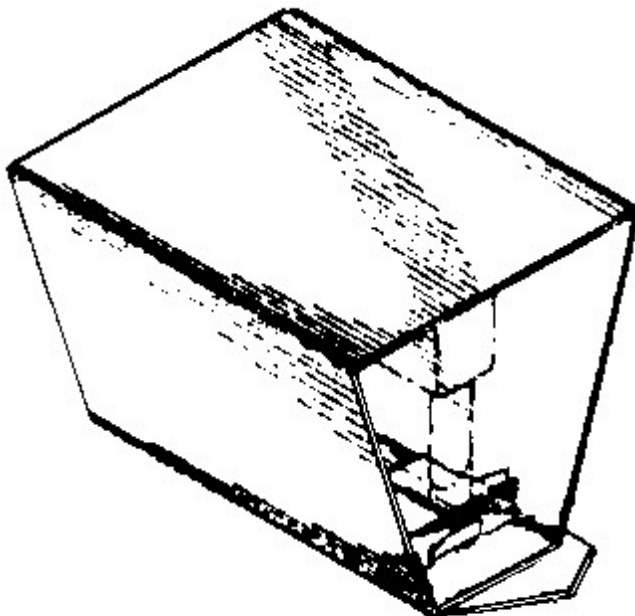

B65D 65/38**Packaging materials of special type or form****References****Limiting references***This place does not cover:*

Shrink or stretch films	B65D 75/00
Combustible packaging for combustible materials	B65D 85/00
Packages for compounding ingredients for rubber, the package being used in the mixing process	C08J 3/22

Special rules of classification

The use of available Indexing Codes is mandatory.

B65D 65/40

Applications of laminates for particular packaging purposes {([B65D 1/0215](#), [B65D 1/28](#), [B65D 3/22](#), [B65D 5/0281](#), [B65D 5/563](#), [B65D 9/30](#), [B65D 29/02](#), [B65D 31/02](#), [B65D 75/26](#), [B65D 77/2024](#), [B65D 81/1275](#), [B65D 81/3811](#), [B65D 81/3823](#), [B65D 81/3834](#), [B65D 81/3846](#), [B65D 81/3858](#), [B65D 81/3874](#), [B65D 81/3886](#), [B65D 81/3897](#) take precedence; laminates per se or laminated packages characterised by the composition or)}

Definition statement*This place covers:*

Illustrative example of subject matter classified in this group:

**References****Limiting references***This place does not cover:*

Bottles or similar containers with necks or like restricted apertures multilayered	B65D 1/0215
Thin-walled containers formed of laminated material	B65D 1/28

Limiting references

Containers having bodies or peripheral walls of curved or partially curved cross-section with double walls; with walls incorporating air-chambers; with walls made of laminated material	B65D 3/22
Containers of polygonal cross-section, the tubular body presenting double or multiple walls	B65D 5/0281
Laminated linings; Coatings	B65D 5/563
Applications of laminates as wall material, e.g. plywood	B65D 9/30
Sacks with laminated or multiple walls	B65D 29/02
Bags or like containers made of paper and having structural provision for thickness of contents with laminated walls	B65D 31/02
Articles or materials wholly enclosed in laminated sheets or wrapper blanks	B65D 75/26
Containers, packaging elements, or packages laminated or bonded to the inner wall of a container	B65D 77/2024
Containers, packaging elements, or packages, for contents presenting particular transport or storage problems, or adapted to be used for non-packaging purposes after removal of contents laminated or bonded to the inner wall of a container	B65D 81/1275
Rigid container in the form of a barrel or vat formed of different materials, e.g. laminated or foam filling between walls	B65D 81/3811
Rigid container being in the form of a box, tray or like container formed of different materials, e.g. laminated or foam filling between walls	B65D 81/3823
Rigid container being in the form of a box, tray or like container with one or more containers located inside the external container formed of different materials, e.g. laminated or foam filling between walls	B65D 81/3834
Rigid container in the form of a bottle, jar or like container formed of different materials, e.g. laminated or foam filling between walls	B65D 81/3846
Semi-rigid container folded up from one or more blanks formed of different materials, e.g. laminated or foam filling between walls	B65D 81/3858
Drinking cups or like containers formed of different materials, e.g. laminated or foam filling between walls	B65D 81/3874
Insulating sleeves or jackets for cans, bottles, barrels formed of different materials, e.g. laminated or foam filling between walls	B65D 81/3886
Containers, packaging elements, or packages, for contents presenting particular transport or storage problems, or adapted to be used for non-packaging purposes after removal of contents, formed of different materials	B65D 81/3897

B65D 65/403

{with at least one corrugated layer}

Definition statement

This place covers:

Illustrative example of subject matter classified in this group:

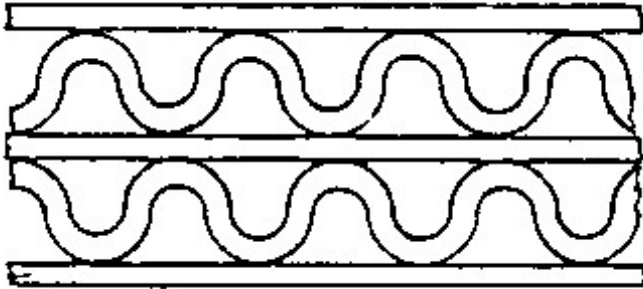

B65D 65/406

{with at least one layer provided with a relief other than corrugations}

Definition statement

This place covers:

Illustrative example of subject matter classified in this group:

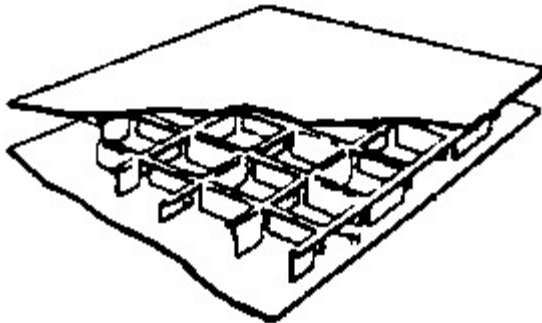

B65D 65/42**Applications of coated or impregnated materials****Definition statement**

This place covers:

Illustrative example of subject matter classified in this group:

**B65D 65/44**

{Applications of resilient shock-absorbing materials, e.g. foamed plastics material, honeycomb material}

Definition statement

This place covers:

Illustrative example of subject matter classified in this group:

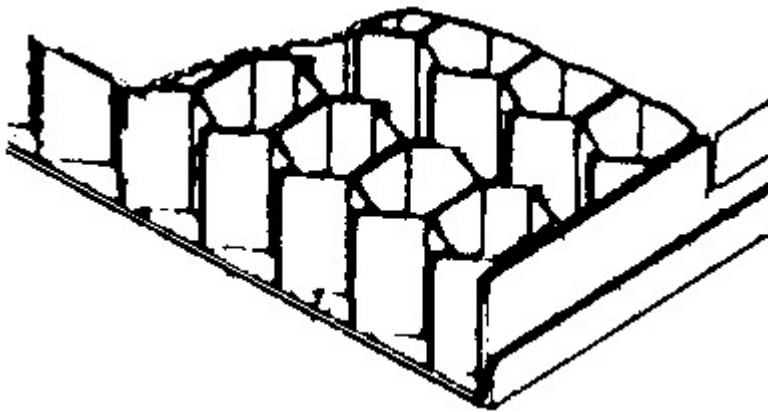
**References****Limiting references**

This place does not cover:

Separating trays for fruit or the like	B65D 1/36 , B65D 85/34
Pallets having honeycomb paper support means	B65D19/34

B65D 65/46**Applications of disintegrable, dissolvable or edible materials****References****Limiting references**

This place does not cover:

Detergent materials	C11D 17/042
Cement mixtures contained in dissolvable bags	E04C 5/012 , E04C 5/073

B65D 65/463**{Edible packaging materials}****References****Informative references**

Attention is drawn to the following places, which may be of interest for search:

Baking; Edible doughs	A21
Food or foodstuffs; Their treatment, not covered by other classes	A23
Food, foodstuffs, or non-alcoholic beverages, not covered by subclasses A23B - A23L ; their preparation or treatment	A23L
Shaping or working of foodstuffs, not fully covered by a single other subclass	A23P

B65D 65/466**{Bio- or photodegradable packaging materials}****References****Informative references**

Attention is drawn to the following places, which may be of interest for search:

Absorbent pads, e.g. sanitary towels, swabs or tampons for external or internal application to the body; Supporting or fastening means therefor; Tampon applicators	A61F 13/15
Details of processes or apparatus for reducing environmental damage or for working-up compositions comprising inert blowing agents or biodegradable components	B29C 44/3402
Parts, details or accessories for books or filing appliances: materials, e.g. biodegradable	B42P 2241/28
Indexing Codes relating to refuse receptacles: Biodegradable	B65F 2250/105

B65D 67/00

Kinds or types of packaging elements not otherwise provided for {([B65D 5/425](#) takes precedence)}

Definition statement

This place covers:

Illustrative example of subject matter classified in this group:

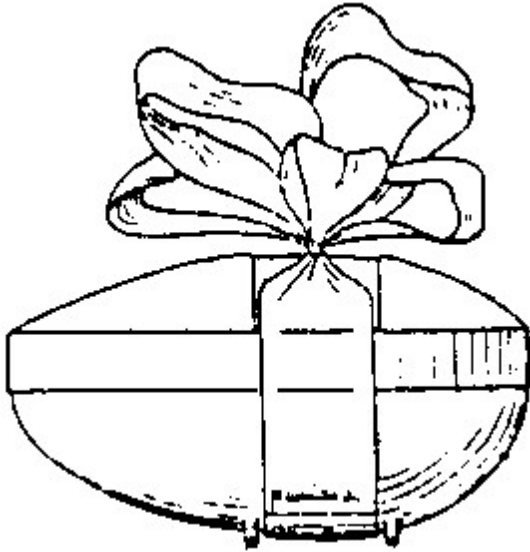
**References****Limiting references**

This place does not cover:

Decorative ribbons or rosettes	B65D 5/4212 , B65D 33/004
Decoration elements	B65D 5/425

B65D 67/02**Clips or clamps for holding articles together for convenience of storage or transport****Definition statement***This place covers:*

Illustrative example of subject matter classified in this group:

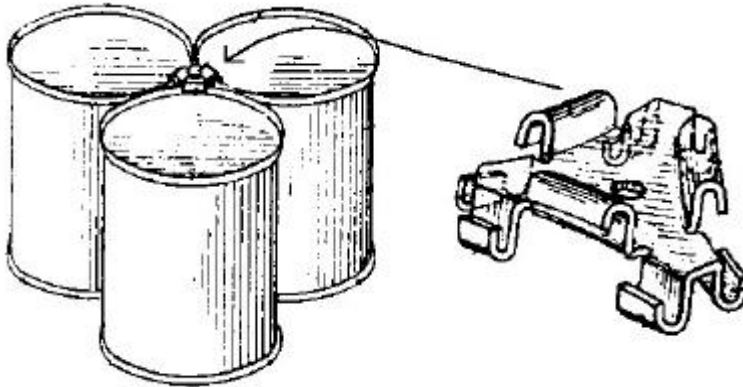
**References****Limiting references***This place does not cover:*

Connectors for solely coaxial connection	B65D 71/502
Releasable fastenings clips	F16B 2/20

Informative references*Attention is drawn to the following places, which may be of interest for search:*

Bundles of articles, held together by packaging elements for convenience of storage or transport, comprising a plurality of articles held together only partially by packaging elements formed otherwise than by folding a blank	B65D 71/50
--	----------------------------

B65D 69/00

Articles joined together for convenience of storage or transport without the use of packaging elements ({packages joined together [B65D 5/427](#), [B65D 21/02](#)} ; joining articles for convenience of packaging [B65B 17/02](#))

Definition statement

This place covers:

Illustrative example of subject matter classified in this group:

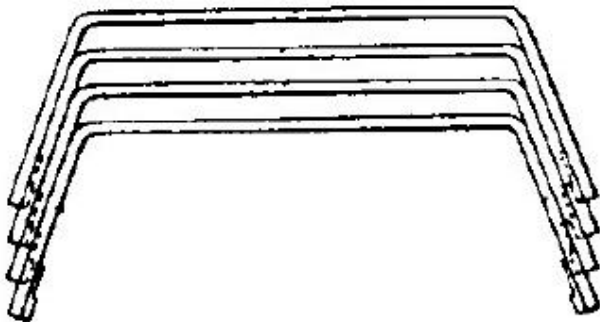
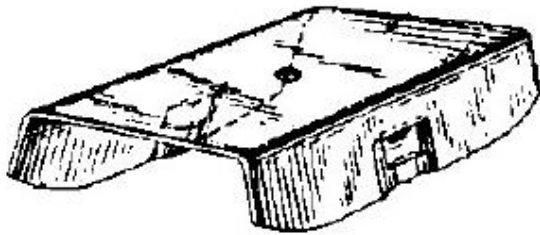

References

Limiting references

This place does not cover:

Coaxial connectors	B65D 71/502
--------------------	-----------------------------

Informative references

Attention is drawn to the following places, which may be of interest for search:

Containers specially shaped, or provided with fittings or attachments stackable or joined together side-by-side	B65D 21/0201
Cylindrical or polygonal containers composed of two or more separate containers joined to each other	B65D 81/3288

B65D 71/00

Bundles of articles held together by packaging elements for convenience of storage or transport, e.g. portable segregating carrier for plural receptacles such as beer cans or pop bottles; Bales of material

References

Limiting references

This place does not cover:

Packages containing several articles intended to be suspended from a display rod	B65D 83/0088
Containers, packaging elements or packages specially adapted for compressible or flexible articles of other shapes	B65D 85/07
Ice-cream cone holders	A47G 23/02
Ice-cream cone carriers	A47G 23/06

Special rules of classification

Documents classed in [B65D 71/0003](#) - [B65D 71/0081](#) and in [B65D 71/12](#) - [B65D 71/38](#) must also get all the possible codes of [B65D 2571/00123](#).

B65D 71/0003

{Tray-like elements provided with handles, for storage or transport of several articles, e.g. bottles, tins, jars}

Definition statement

This place covers:

Illustrative example of subject matter classified in this group:

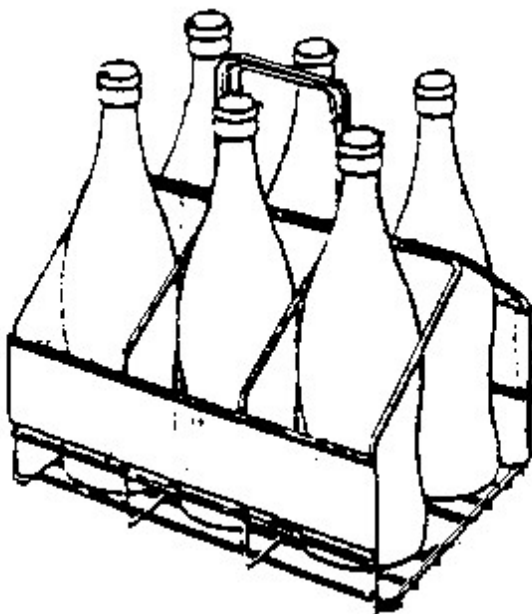

Special rules of classification

The use of available Indexing Codes is mandatory.

B65D 71/0007

{without partitions}

Definition statement

This place covers:

Illustrative example of subject matter classified in this group:

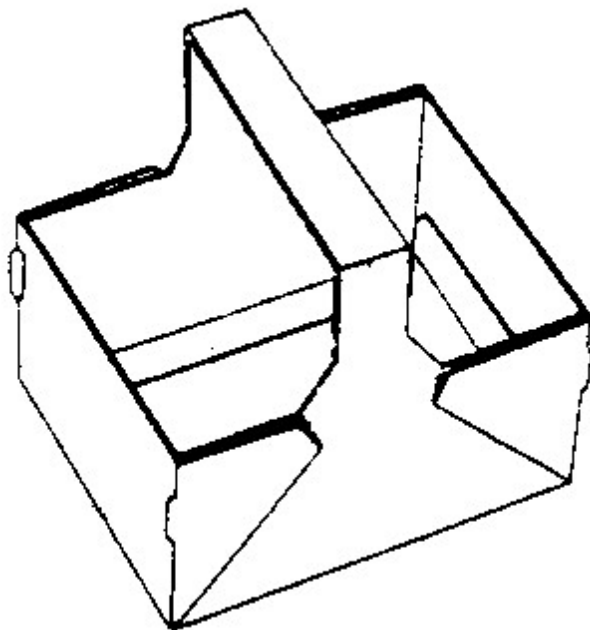

Special rules of classification

The use of available Indexing Codes is mandatory.

B65D 71/0014

{with one longitudinal partition}

Definition statement

This place covers:

Illustrative example of subject matter classified in this group:

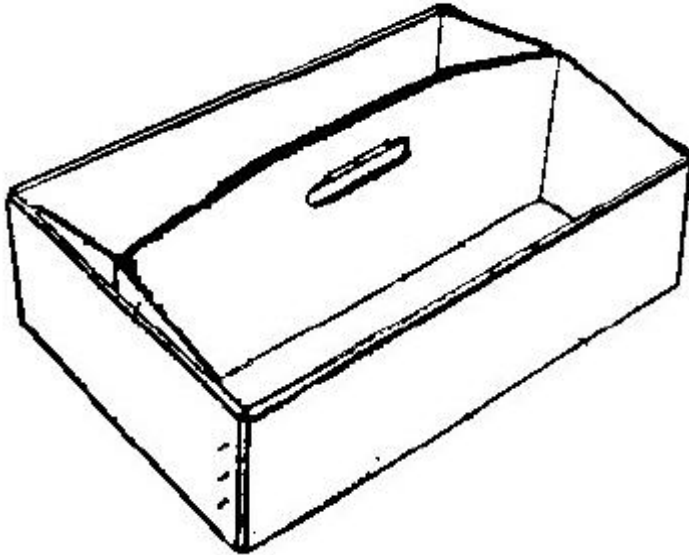

Special rules of classification

The use of available Indexing Codes is mandatory.

B65D 71/0022

{formed by folding or erecting one blank, and provided with vertical partitions}

Definition statement

This place covers:

Illustrative example of subject matter classified in this group:

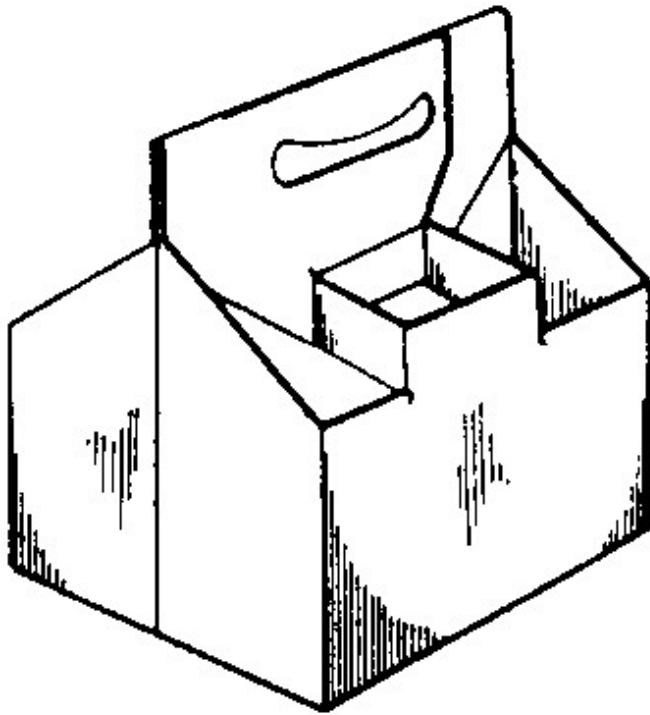
**References*****Limiting references***

This place does not cover:

Formed by folding one blank so as to form a tubular element in which the upper wall is provided with openings through which the articles extend partially	B65D 71/0029
---	------------------------------

Special rules of classification

The use of available Indexing Codes is mandatory.

B65D 71/0033

{with parts of the walls bent against one another so as to form a longitudinal partition for two rows of articles}

Definition statement

This place covers:

Illustrative example of subject matter classified in this group:

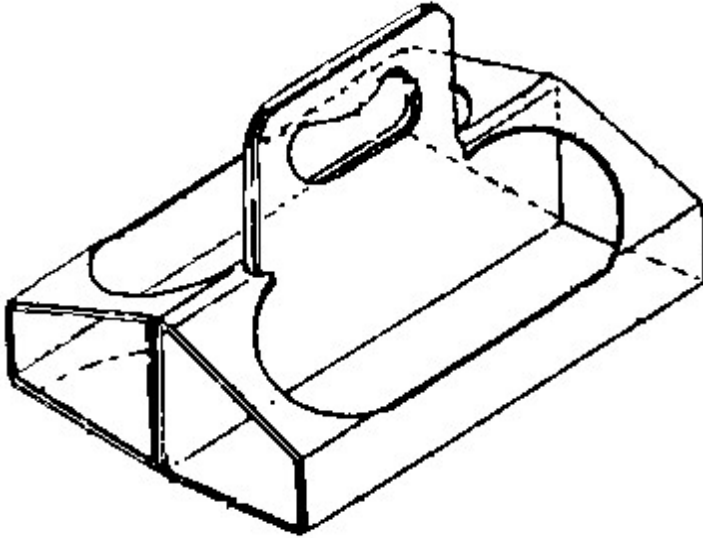

Special rules of classification

The use of available Indexing Codes is mandatory.

B65D 71/0037

{with additional locating elements for the articles}

Definition statement

This place covers:

Illustrative example of subject matter classified in this group:

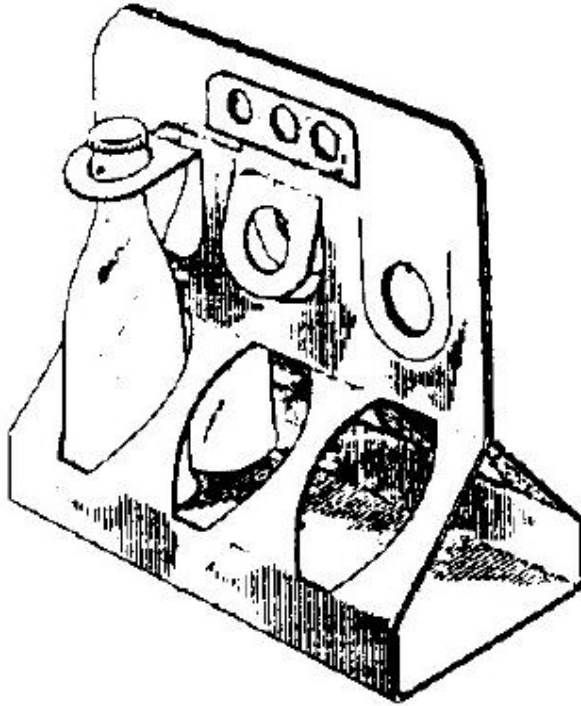

Special rules of classification

The use of available Indexing Codes is mandatory.

B65D 71/0048

{with walls wrapping around a great part of the articles}

Definition statement

This place covers:

Illustrative example of subject matter classified in this group:

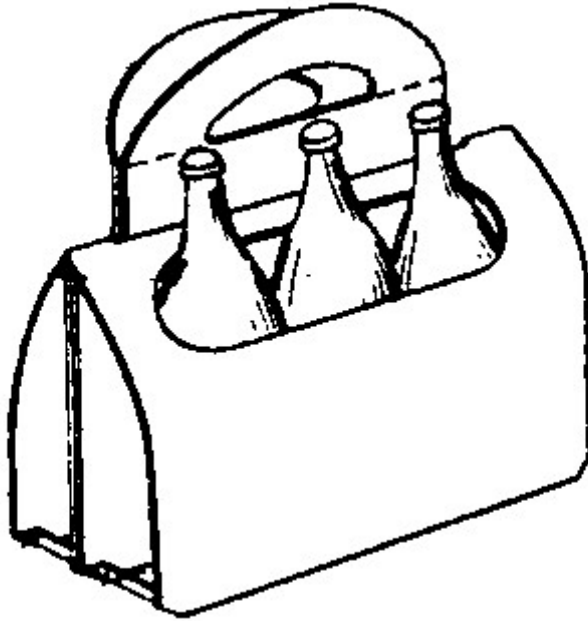

Special rules of classification

The use of available Indexing Codes is mandatory.

B65D 71/0051

{with additional locating elements for the articles}

Definition statement

This place covers:

Illustrative example of subject matter classified in this group:

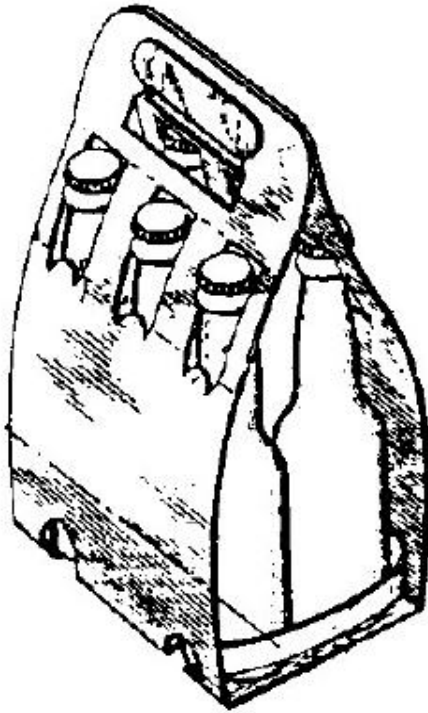

Special rules of classification

The use of available Indexing Codes is mandatory.

B65D 71/0062

{for holding one row of articles}

Definition statement

This place covers:

Illustrative example of subject matter classified in this group:

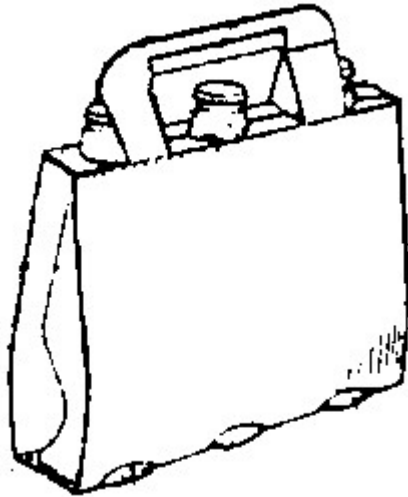

Special rules of classification

The use of available Indexing Codes is mandatory.

B65D 71/0066

{with additional locating elements for the articles}

Definition statement

This place covers:

Illustrative example of subject matter classified in this group:

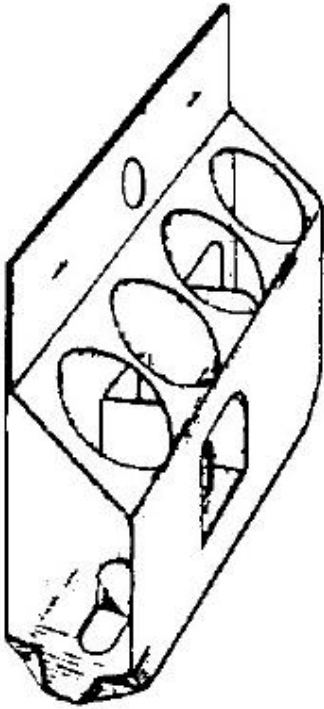

Special rules of classification

The use of available Indexing Codes is mandatory.

B65D 71/0077

{formed by folding and interconnecting of two or more blanks}

Definition statement

This place covers:

Illustrative example of subject matter classified in this group:

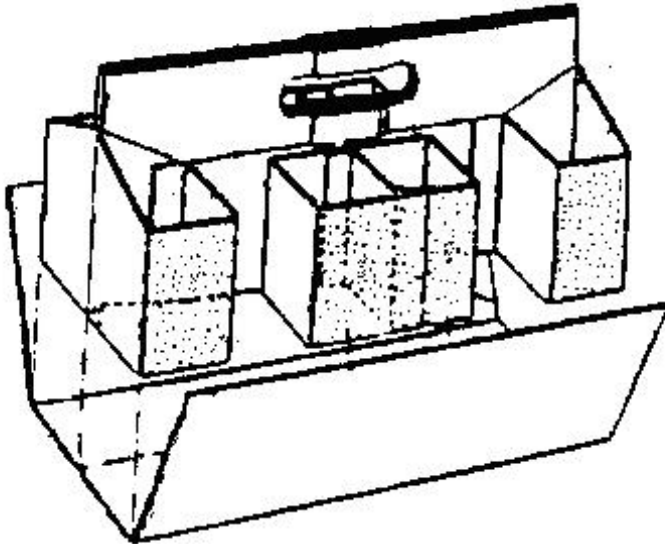

Special rules of classification

The use of available Indexing Codes is mandatory.

B65D 71/0081

{with separately attached handles}

Special rules of classification

The use of available Indexing Codes is mandatory.

B65D 71/0085

{Packaging elements adhered to the articles, e.g. a carton sheet (adhesive tapes [B65D 63/1009](#))}

Definition statement

This place covers:

Illustrative example of subject matter classified in this group:

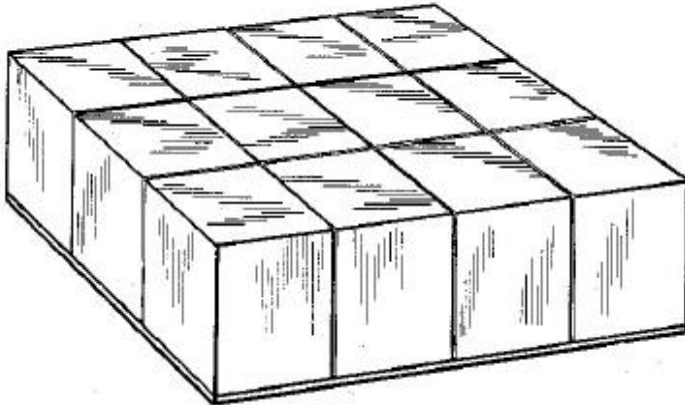
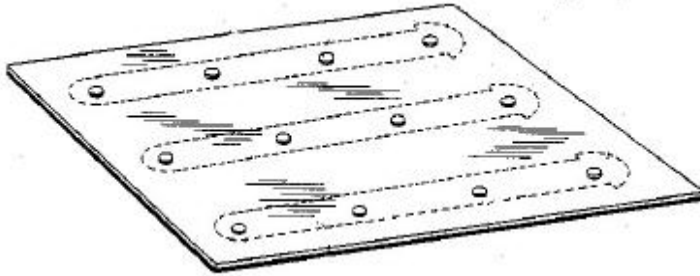

References

Informative references

Attention is drawn to the following places, which may be of interest for search:

Adhesive or cohesive means for holding the contents attached to the container	B65D 2313/10
---	------------------------------

B65D 71/0088

{Palletisable loads, i.e. loads intended to be transported by means of a fork-lift truck}

Definition statement

This place covers:

Illustrative example of subject matter classified in this group:

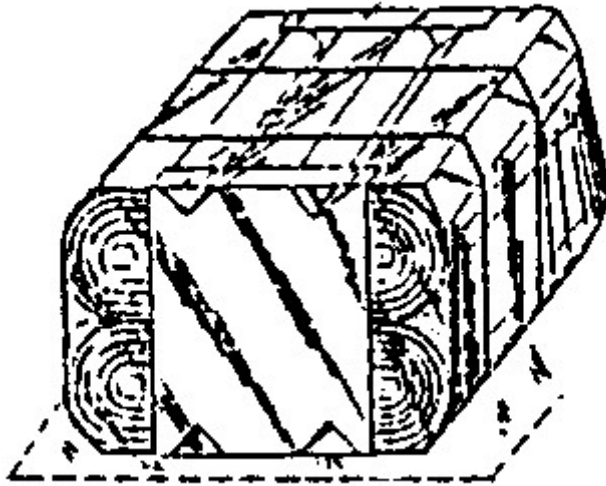

Special rules of classification

The use of available Indexing Codes is mandatory.

B65D 71/0092

{provided with one or more rigid supports, at least one dimension of the supports corresponding to a dimension of the load, e.g. skids}

Definition statement

This place covers:

Illustrative example of subject matter classified in this group:

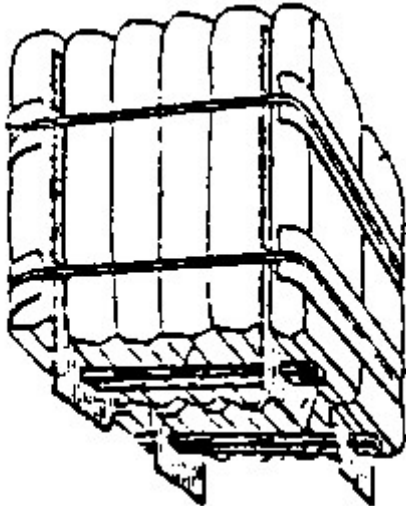

Special rules of classification

The use of available Indexing Codes is mandatory.

B65D 71/0096

{the dimensions of the supports corresponding to the periphery of the load, e.g. pallets}

Definition statement

This place covers:

Illustrative example of subject matter classified in this group:

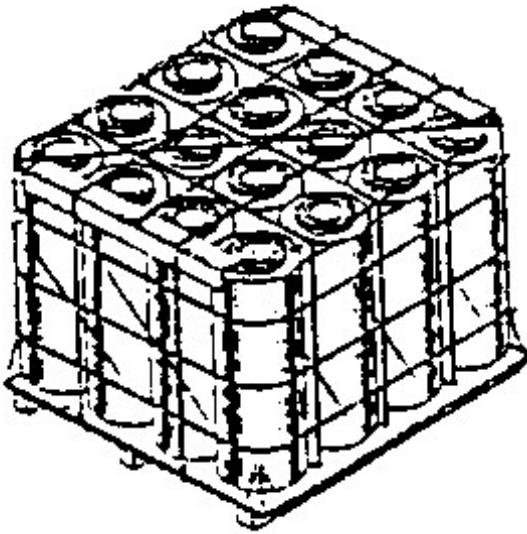

Special rules of classification

The use of available Indexing Codes is mandatory.

B65D 71/02**Arrangements of flexible binders****Definition statement**

This place covers:

Illustrative example of subject matter classified in this group:

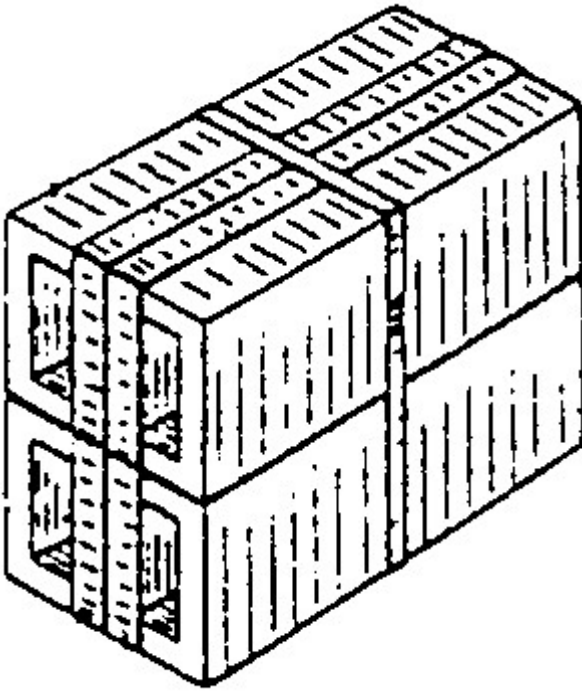
**References****Limiting references**

This place does not cover:

Palletisable loads whereby the binder is not described	B65D 71/0088
When the binder is not described	B65D 71/02
Slings	B66C 1/00

Special rules of classification

The use of available Indexing Codes is mandatory.

B65D 71/04

with protecting or supporting elements arranged between binder and articles or materials, e.g. for preventing chafing of binder

Definition statement

This place covers:

Illustrative example of subject matter classified in this group:

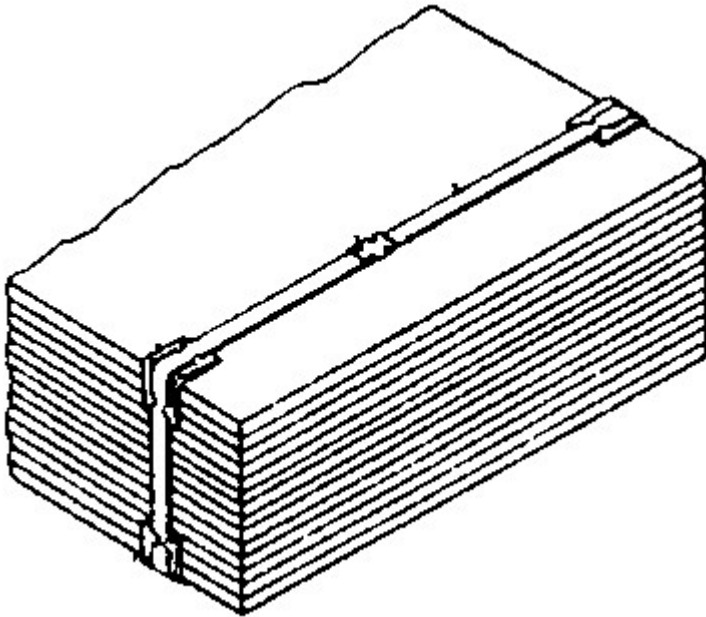
**References****Limiting references**

This place does not cover:

Palletisable loads whereby the element is not described	B65D 71/0088
When the element is not described	B65D 71/04
Slings with load protectors	B66C 1/122

Informative references

Attention is drawn to the following places, which may be of interest for search:

Corner, edge or end protectors	B65D 81/053
--------------------------------	-----------------------------

B65D 71/06

Packaging elements holding or encircling completely or almost completely the bundle of articles, e.g. wrappers

References**Informative references**

Attention is drawn to the following places, which may be of interest for search:

Containers of polygonal cross-section the tubular body having no end closures	B65D 5/04
---	---------------------------

Special rules of classification

The use of available Indexing Codes is mandatory.

B65D 71/063

{Wrappers formed by one or more films or the like, e.g. nets ([B65D 71/08](#) takes precedence; wrappers formed by folding a single blank [B65D 71/12](#); wrappers formed by folding two or more blanks [B65D 71/38](#))}

References**Limiting references**

This place does not cover:

Nets per se	B65D 29/00
Wrappers shrunk by heat	B65D 71/08

B65D 71/066

{and provided with inserts ([B65D 7/10](#) takes precedence)}

Definition statement

This place covers:

Illustrative example of subject matter classified in this group:

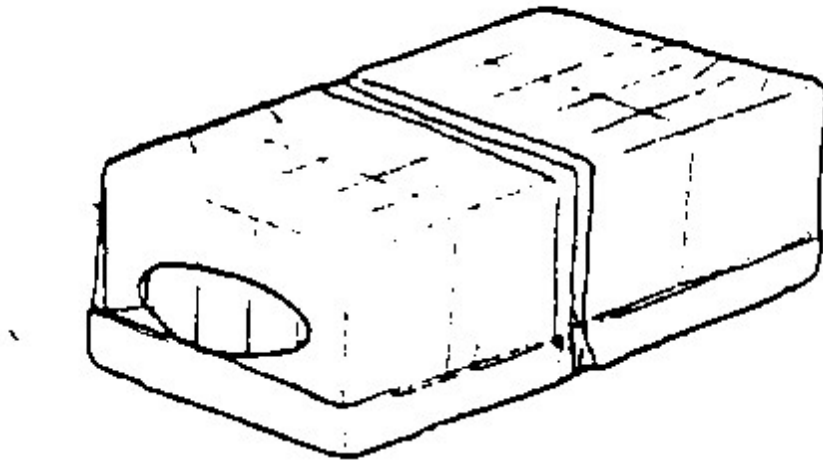
**References*****Limiting references***

This place does not cover:

Containers having bodies formed by interconnecting or uniting two or more rigid, or substantially rigid, components made wholly or mainly of metal: Of drawer-and-shell type	B65D 7/10
--	---------------------------

B65D 71/08

Wrappers shrunk by heat {or under tension, e.g. stretch films or films tensioned by compressed articles}

Definition statement

This place covers:

Illustrative example of subject matter classified in this group:

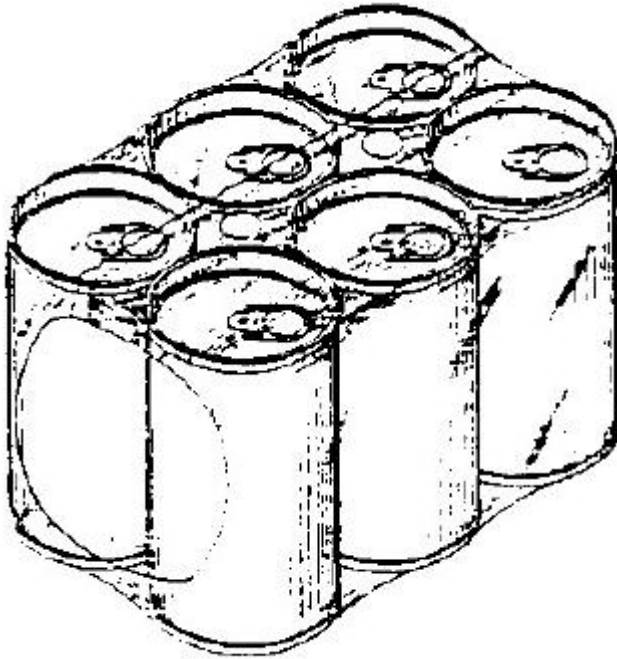

B65D 71/125

{not having a tubular shape}

Definition statement

This place covers:

Illustrative example of subject matter classified in this group:

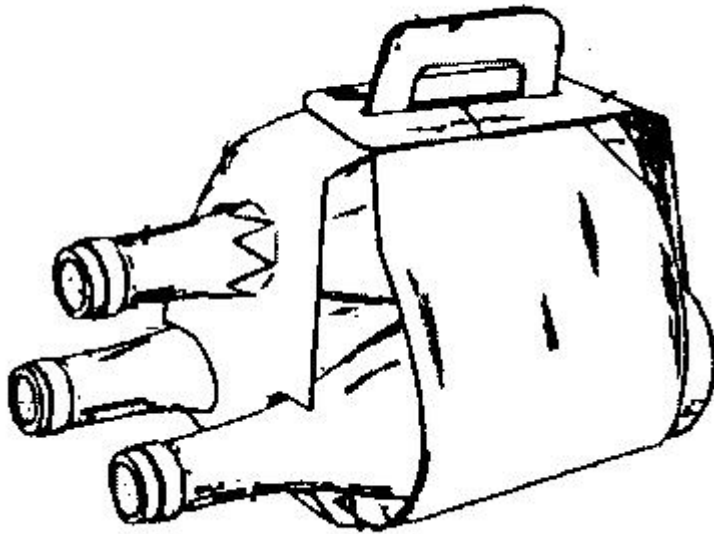

Special rules of classification

The use of available Indexing Codes is mandatory.

B65D 71/16

with article-locating elements

Definition statement

This place covers:

Illustrative example of subject matter classified in this group:

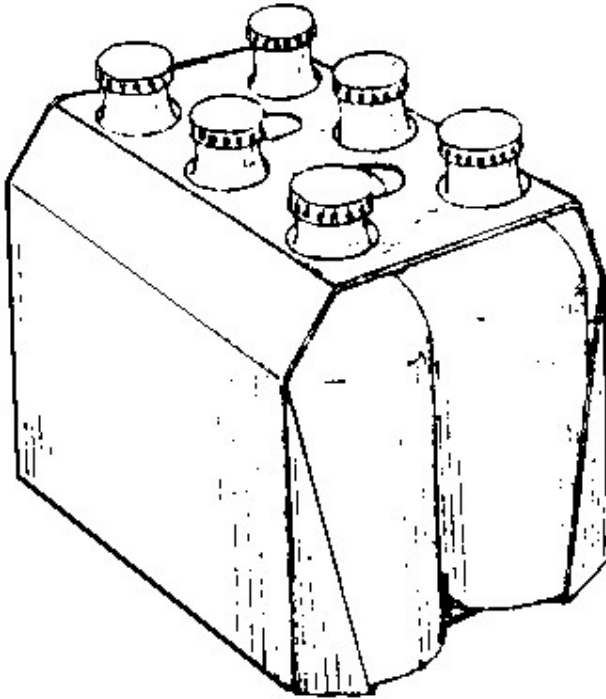

References

Informative references

Attention is drawn to the following places, which may be of interest for search:

Tabs or other projections for locating contents	B65D 65/24
---	----------------------------

Special rules of classification

The use of available Indexing Codes is mandatory.

B65D 71/18

Tabs inwardly folded tabs from the upper or lower wall

Definition statement

This place covers:

Illustrative example of subject matter classified in this group:

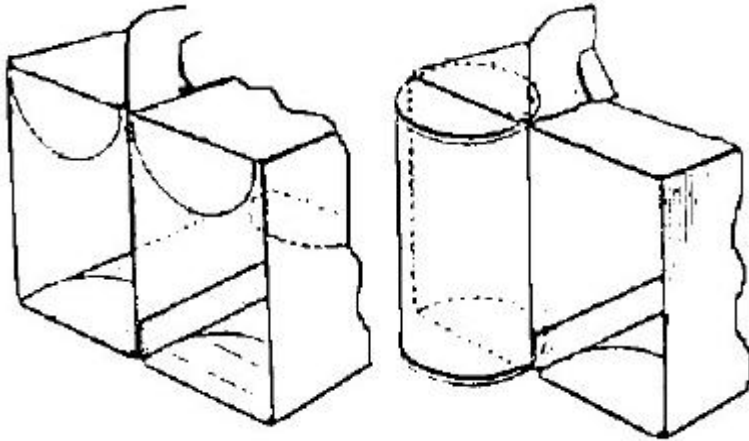

Special rules of classification

The use of available Indexing Codes is mandatory.

B65D 71/20

Slits or openings along the fold line of the tubular body

Definition statement

This place covers:

Illustrative example of subject matter classified in this group:

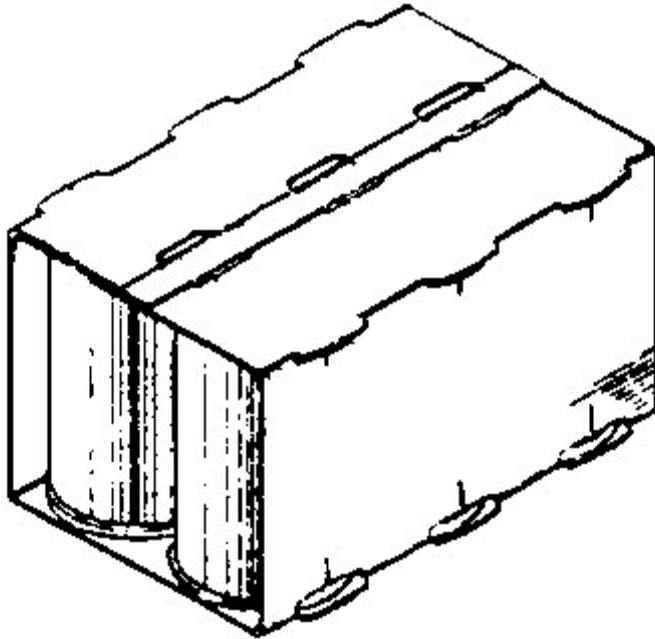

Special rules of classification

The use of available Indexing Codes is mandatory.

B65D 71/22

Openings or windows formed in the side walls

Definition statement

This place covers:

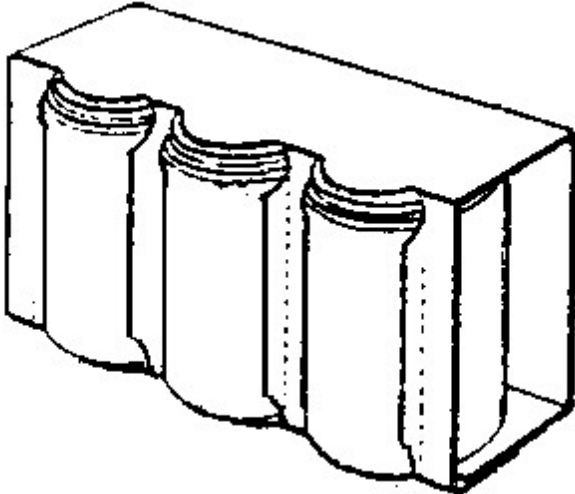

Special rules of classification

The use of available Indexing Codes is mandatory.

B65D 71/243

{extending from the side walls}

Definition statement

This place covers:

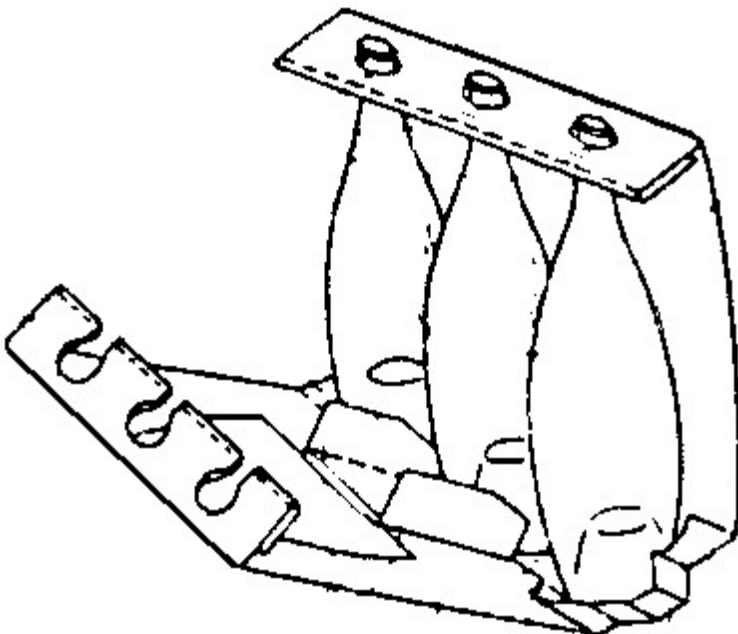

Special rules of classification

The use of available Indexing Codes is mandatory.

B65D 71/246

{Inserted partitions}

Definition statement

This place covers:

Illustrative example of subject matter classified in this group:

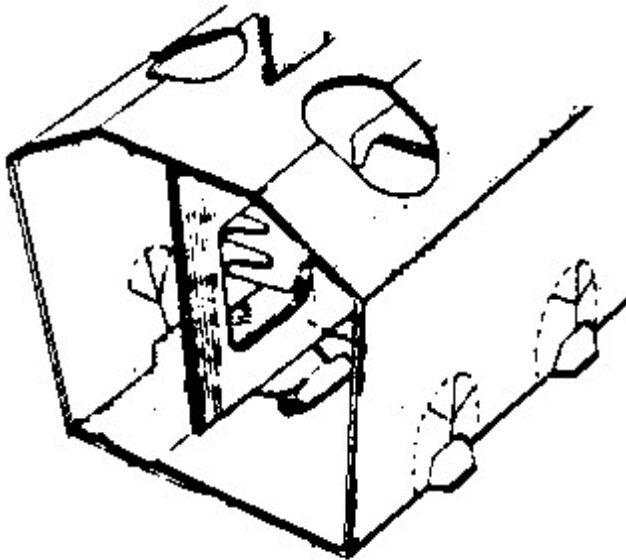

Special rules of classification

The use of available Indexing Codes is mandatory.

B65D 71/26

extending from the upper or lower wall

Definition statement

This place covers:

Illustrative example of subject matter classified in this group:

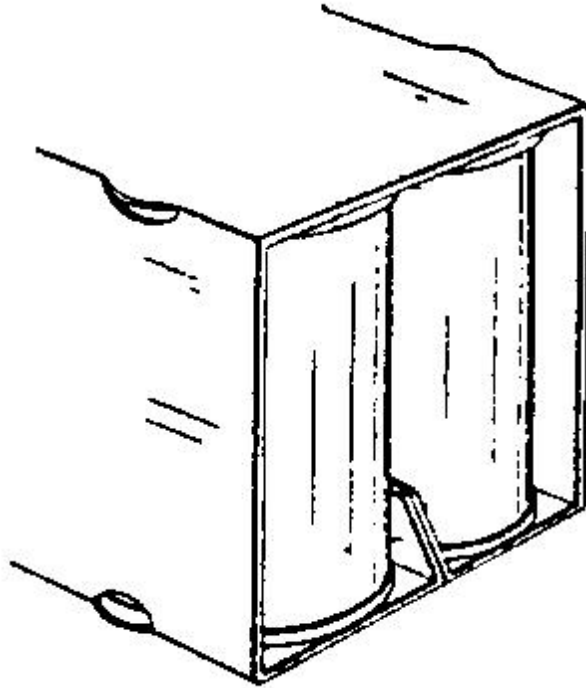

Special rules of classification

The use of available Indexing Codes is mandatory.

B65D 71/285

{Separately-attached handles}

Definition statement

This place covers:

Illustrative example of subject matter classified in this group:

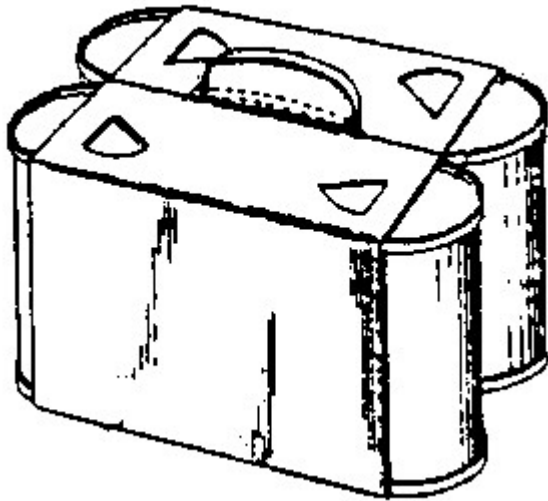

Special rules of classification

The use of available Indexing Codes is mandatory.

B65D 71/30

unitary {, i.e. integral} with the tubular packaging elements

Definition statement

This place covers:

Illustrative example of subject matter classified in this group:

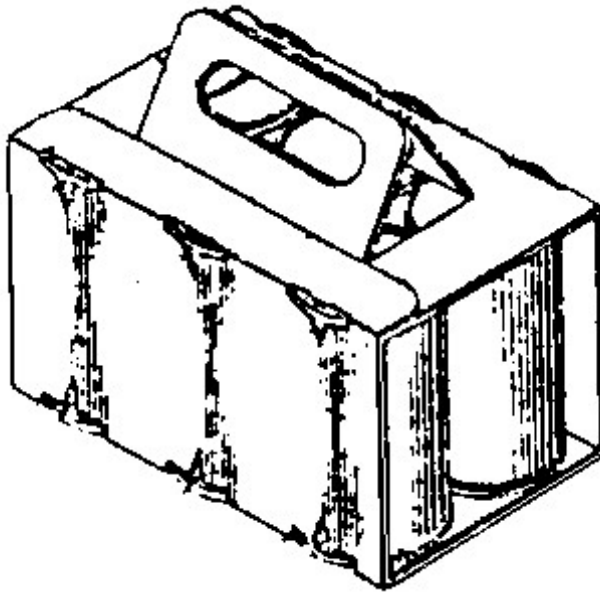

References

Informative references

Attention is drawn to the following places, which may be of interest for search:

With walls wrapping around a great part of the articles	B65D 71/0048
---	------------------------------

Special rules of classification

The use of available Indexing Codes is mandatory.

B65D 71/32

formed by finger-holes

Definition statement

This place covers:

Illustrative example of subject matter classified in this group:

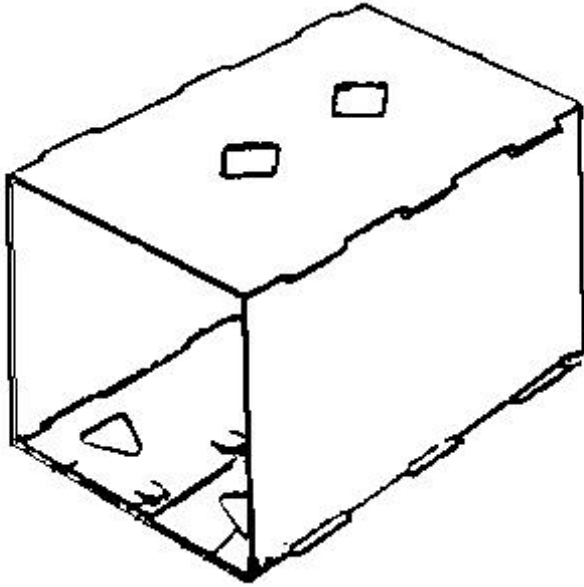

Special rules of classification

The use of available Indexing Codes is mandatory.

B65D 71/34

characterised by {weakened lines or other opening devices}

Definition statement

This place covers:

Illustrative example of subject matter classified in this group:

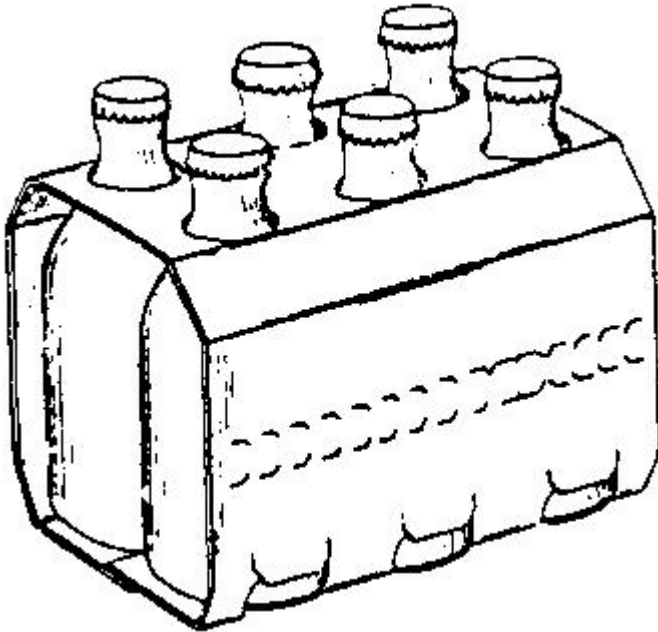

Special rules of classification

The use of available Indexing Codes is mandatory.

B65D 71/36

{having a tubular shape, e.g. tubular wrappers, with} end walls

Definition statement

This place covers:

Illustrative example of subject matter classified in this group:

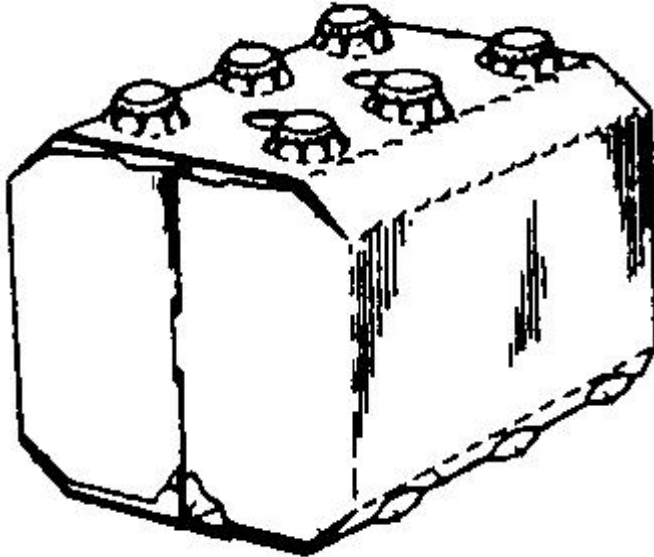

Special rules of classification

The use of available Indexing Codes is mandatory.

B65D 71/38

the packaging elements {, e.g. wrappers} being formed by folding and interconnecting two or more blanks

Definition statement

This place covers:

Illustrative example of subject matter classified in this group:

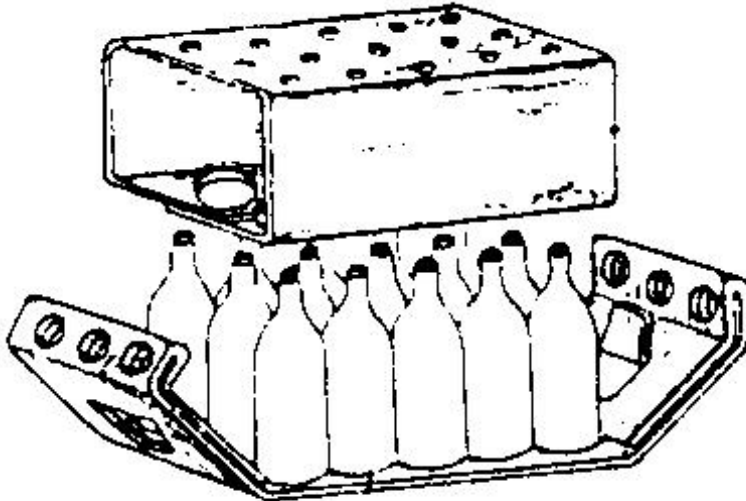
**Special rules of classification**

The use of available Indexing Codes is mandatory.

B65D 71/40

comprising a plurality of articles held together only partially by packaging elements formed by folding a blank {or several blanks}

References**Limiting references**

This place does not cover:

Packages comprising articles attached to cards, sheets, or webs combined with a preformed enclosure	B65D 73/0092
---	------------------------------

B65D 71/403

{formed by folding several blanks}

Definition statement

This place covers:

Illustrative example of subject matter classified in this group:

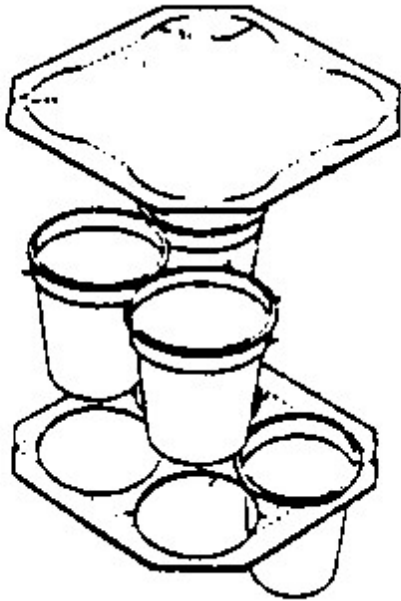

B65D 71/42

formed by folding a single blank into a single layer element

Definition statement

This place covers:

Illustrative example of subject matter classified in this group:

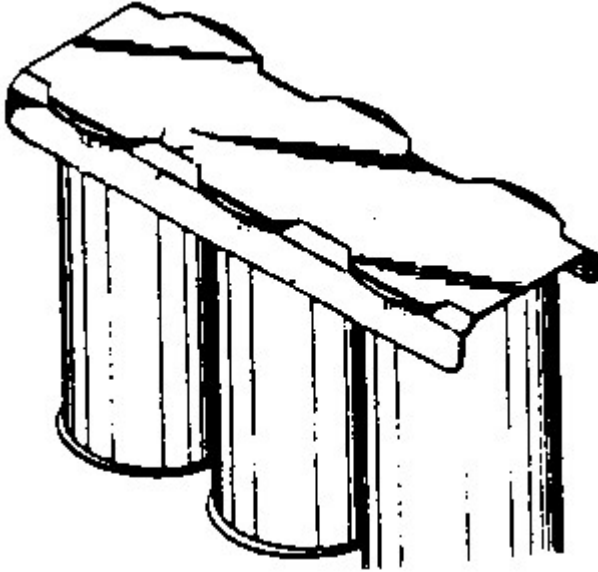

B65D 71/44

characterised by the handle

Definition statement

This place covers:

Illustrative example of subject matter classified in this group:

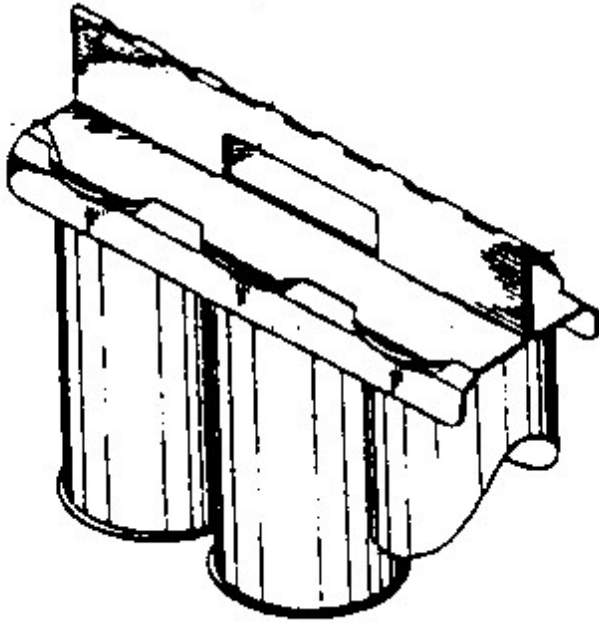
**References*****Limiting references***

This place does not cover:

Wrappers fixed only by adhesives	B65D 71/0085
----------------------------------	------------------------------

B65D 71/46

formed by folding a single blank into a tubular element

Definition statement

This place covers:

Illustrative example of subject matter classified in this group:

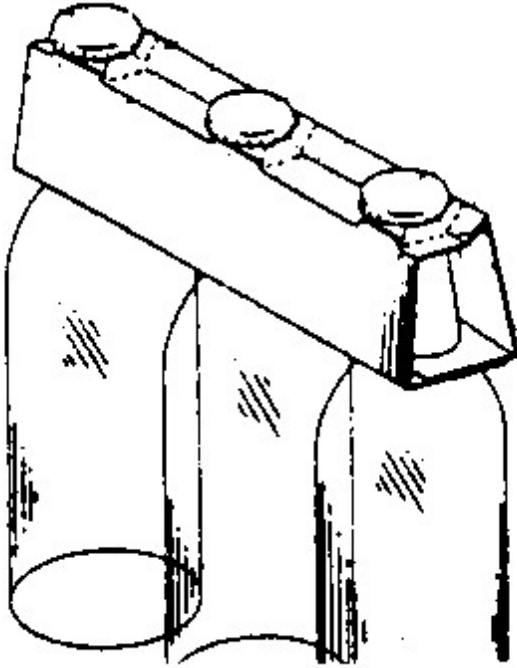

B65D 71/48

characterised by the handle

Definition statement

This place covers:

Illustrative example of subject matter classified in this group:

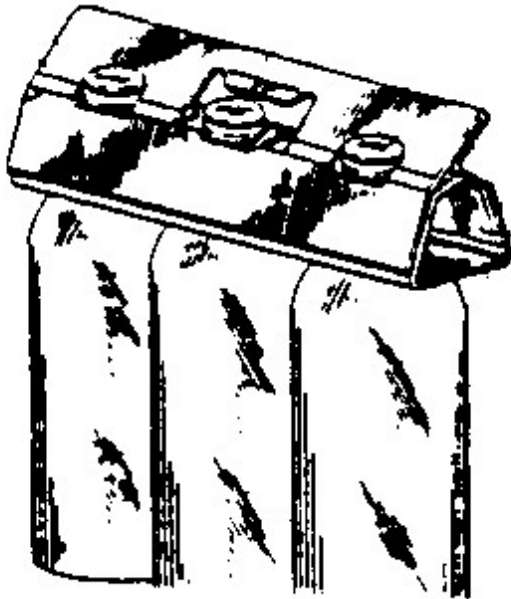

B65D 71/50

comprising a plurality of articles held together only partially by packaging elements formed otherwise than by folding a blank

Definition statement

This place covers:

Illustrative example of subject matter classified in this group:

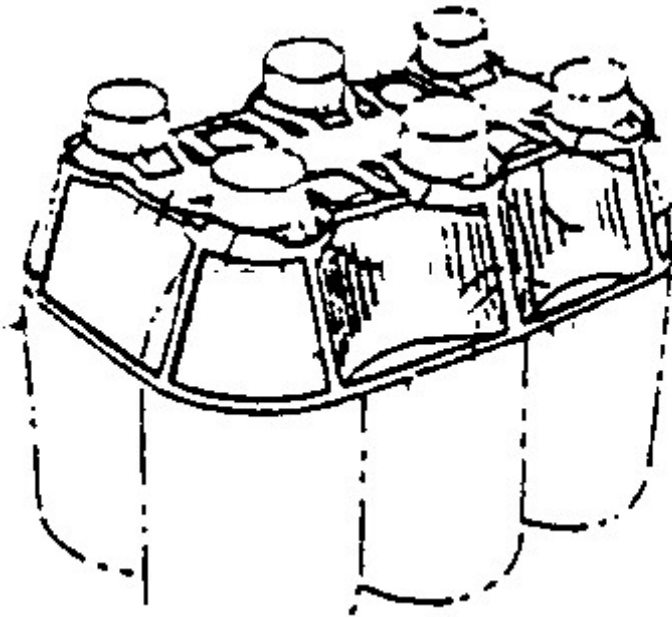
**References****Limiting references**

This place does not cover:

Connectors or clips for coaxial and parallel connection	B65D 67/02
Packaging elements adhered to the articles	B65D 71/0085
Flexible binders	B65D 71/02
Trays	B65D 71/70
Releasable fastenings clips	F16B 2/20

Informative references

Attention is drawn to the following places, which may be of interest for search:

Articles partially enclosed in folded or wound strips or sheets, e.g. wrapped newspapers	B65D 75/02
--	----------------------------

B65D 71/502**{Coaxial connections}****Definition statement***This place covers:*

Illustrative example of subject matter classified in this group:

**References****Limiting references***This place does not cover:*

Connectors or clips for coaxial and parallel connection	B65D 67/02
Coaxial connectors made by folding a blank	B65D 71/40
Releasable fastenings clips	F16B 2/20

Informative references*Attention is drawn to the following places, which may be of interest for search:*

Auxiliary removable stacking elements other than covers	B65D 21/0224
Separate rigid or semi-rigid containers joined to each other at their external surfaces	B65D 81/3205

B65D 71/504

{the element being formed from a flexible sheet provided with slits or apertures intended to be stretched over the articles and adapt to the shape of the article}

Definition statement

This place covers:

Illustrative example of subject matter classified in this group:

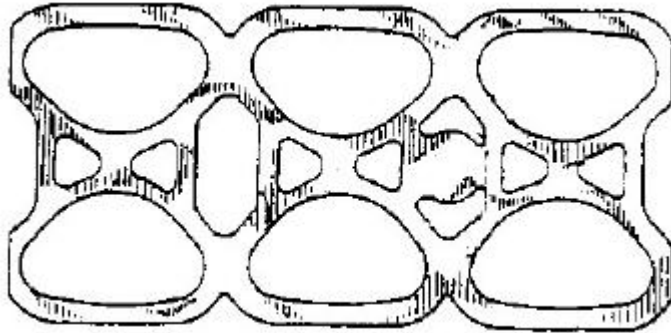

References

Limiting references

This place does not cover:

Joining articles, e.g. cans, using a top carrier element
--

B65B 17/025

B65D 71/506

{and provided with an additional element encircling the periphery of the group of articles}

Definition statement

This place covers:

Illustrative example of subject matter classified in this group:

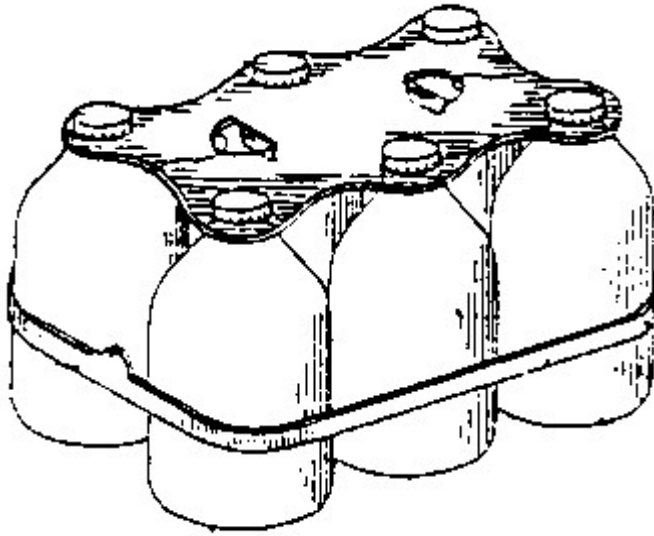

B65D 71/508

{the elements being formed by one or more films or similar, e.g. nets}

Definition statement

This place covers:

Illustrative example of subject matter classified in this group:

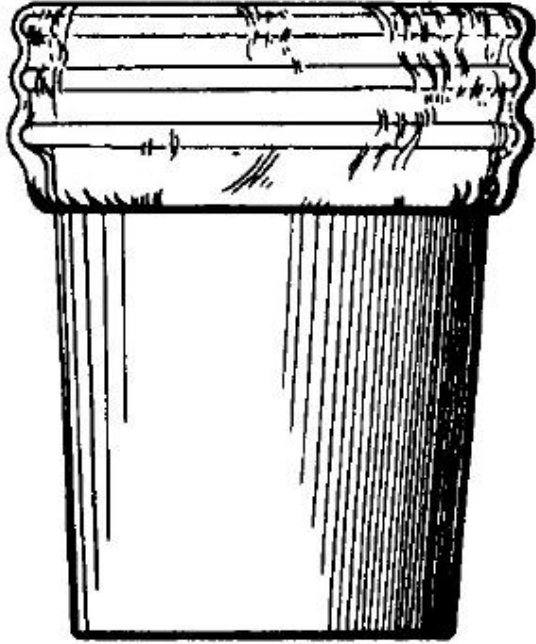

B65D 71/70

Trays provided with projections or recesses in order to assemble multiple articles, e.g. intermediate elements for stacking

Definition statement

This place covers:

Illustrative example of subject matter classified in this group:

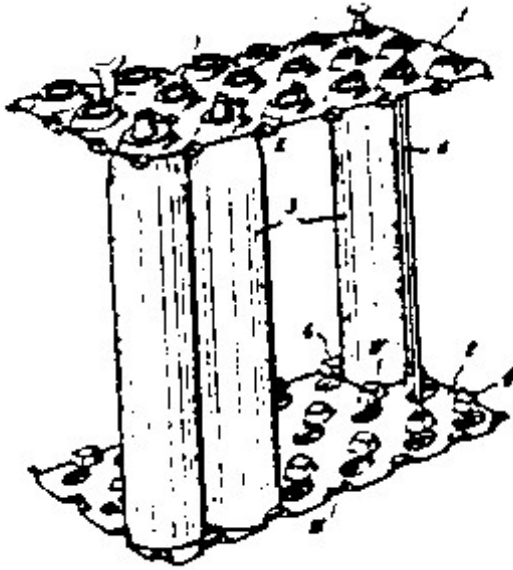

References

Limiting references

This place does not cover:

Stack holders or separators	B65G 1/14
-----------------------------	---------------------------

B65D 71/72

formed by folding one or more blanks, the articles being inserted in openings in a wall

Definition statement

This place covers:

Illustrative example of subject matter classified in this group:

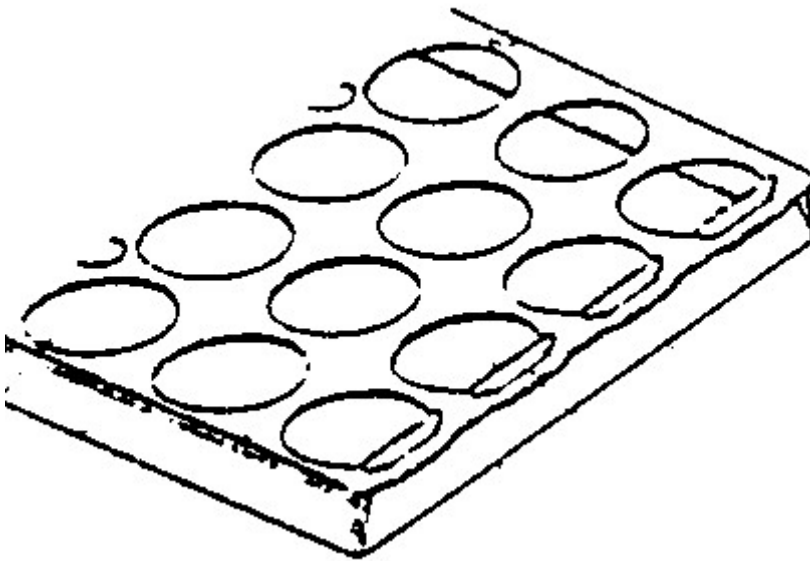
**References****Informative references**

Attention is drawn to the following places, which may be of interest for search:

Tray-like elements formed by folding a blank and presenting openings or recesses	B65D 5/5038
Devices, e.g. plates, presenting apertures through which the articles project	B65D 25/108

B65D 73/00

Packages comprising articles attached to cards, sheets or webs (([B65D 85/18](#) takes precedence))

References**Limiting references**

This place does not cover:

Skin packages	B65D 75/305
Containers, packaging elements or packages specially adapted for wearing apparel	B65D 85/18

B65D 73/0007

{the articles being attached to the plane surface of a single card ([B65D 75/30](#) takes precedence)}

References**Limiting references**

This place does not cover:

Articles or materials enclosed between two opposed sheets or blanks having their margins united, e.g. by pressure-sensitive adhesive, crimping, heat-sealing, or welding	B65D 75/30
--	----------------------------

Informative references

Attention is drawn to the following places, which may be of interest for search:

The articles being supported by or suspended from a tag-like element (hangers for wearing apparel)	B65D 73/0064
--	------------------------------

B65D 73/0014

{by means of separate fixing elements, e.g. clips, clamps, bands}

Definition statement

This place covers:

Illustrative example of subject matter classified in this group:

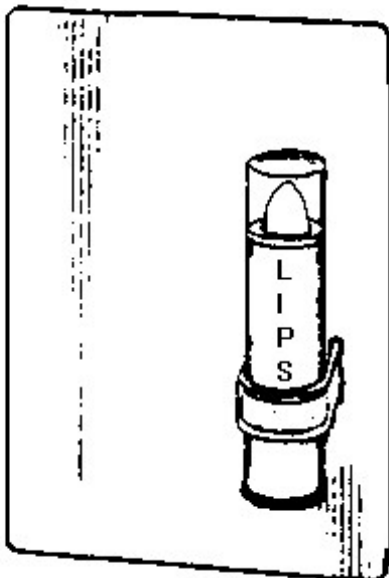

References**Limiting references**

This place does not cover:

Releasable fastenings clips	F16B 2/20
-----------------------------	---------------------------

B65D 73/0021

{by means of cut-out or marginal tabs, tongues or flaps}

Definition statement

This place covers:

Illustrative example of subject matter classified in this group:

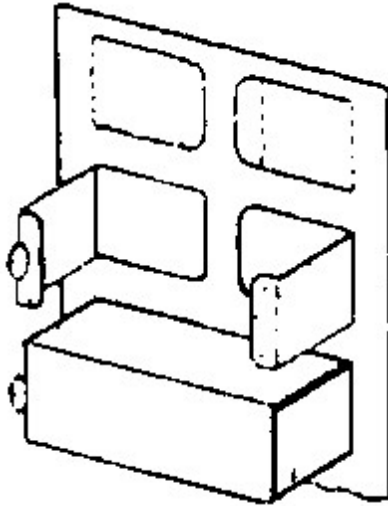

B65D 73/0028

{by means of adhesive, heat-seal or the like}

Definition statement

This place covers:

Illustrative example of subject matter classified in this group:

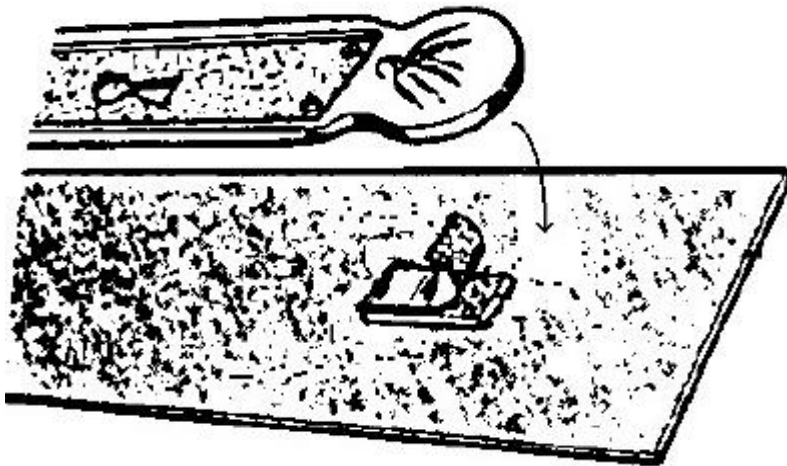
**B65D 73/0035**

{the articles being retained within a recess or a series of recesses provided in a single card ([B65D 75/32](#) takes precedence)}

Definition statement

This place covers:

Illustrative example of subject matter classified in this group:

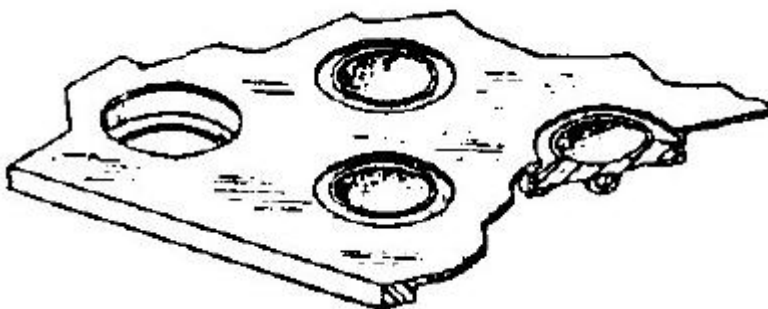
**References****Limiting references**

This place does not cover:

Articles or materials enclosed between two opposed sheets or blanks having their margins united, one or both sheets or blanks being recessed to accommodate contents	B65D 75/32
Button-cards	A44B 7/00

B65D 73/0042

{the articles being retained within a window, hole or other cut-out portion of a single card}

References**Informative references**

Attention is drawn to the following places, which may be of interest for search:

Within a window, hole or cut-out portion	B65D 73/0085
--	------------------------------

B65D 73/005

{by means of separate fixing elements, e.g. clips, clamps, bands}

Definition statement

This place covers:

Illustrative example of subject matter classified in this group:

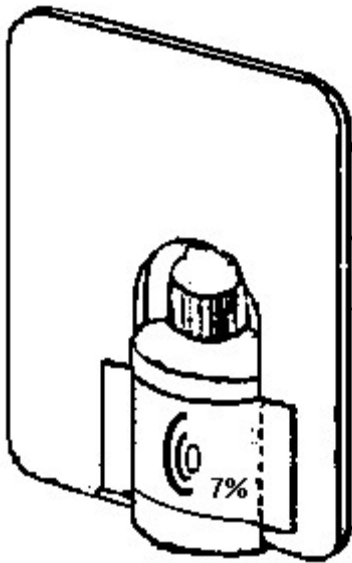
**References****Limiting references**

This place does not cover:

Releasable fastenings clips	F16B 2/20
-----------------------------	---------------------------

B65D 73/0057

{by means of a preformed enclosure, e.g. a bulb}

Definition statement

This place covers:

Illustrative example of subject matter classified in this group:

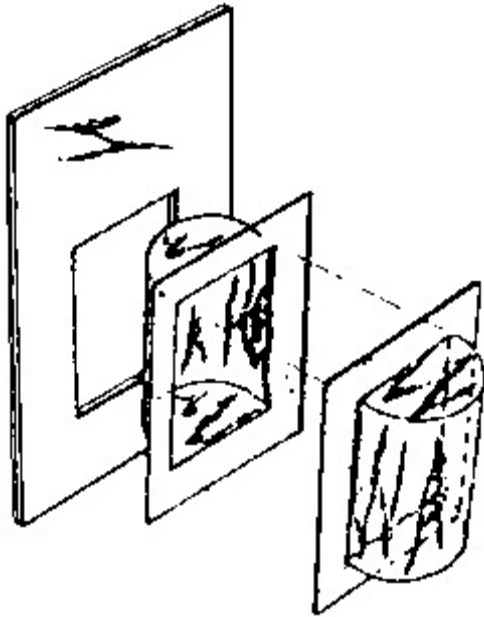

B65D 73/0064

{the articles being supported by or suspended from a tag-like element}

Definition statement

This place covers:

Illustrative example of subject matter classified in this group:

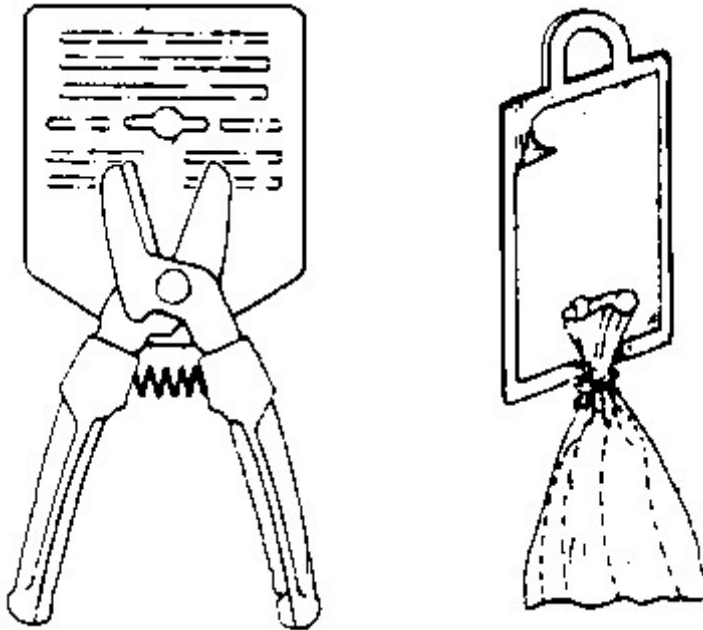
**References****Informative references**

Attention is drawn to the following places, which may be of interest for search:

The articles being attached to the plane surface of a single card	B65D 73/0007
Hangers for hanging articles on bars, tringles, bracket arms or the like	A47F 5/0006

B65D 73/0071

{the tag-like element being doubled-over to engage the upper part of the article}

Definition statement

This place covers:

Illustrative example of subject matter classified in this group:

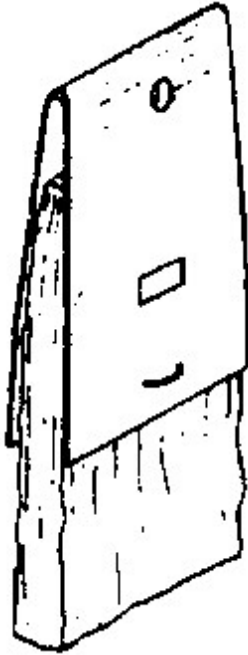

Special rules of classification

The use of available Indexing Codes is mandatory.

B65D 73/0085

{within a window, hole or cut-out portion}

Definition statement

This place covers:

Illustrative example of subject matter classified in this group:

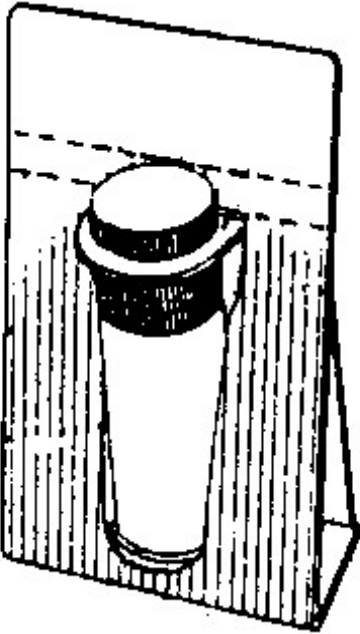

B65D 73/0092

{combined with a preformed enclosure, e.g. a bulb}

Definition statement

This place covers:

Illustrative example of subject matter classified in this group:

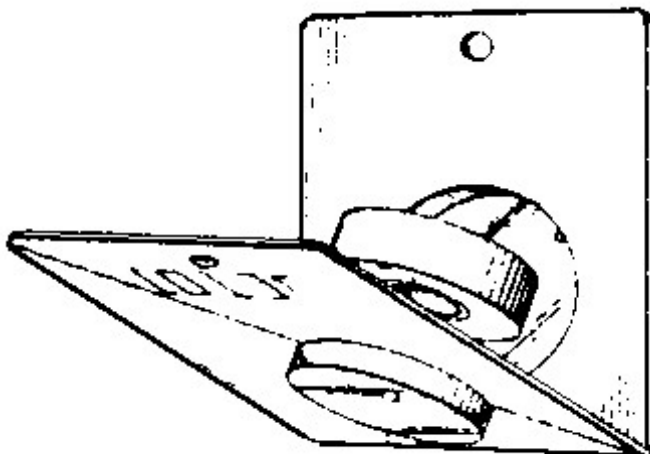

B65D 73/02

Articles, e.g. small electrical components, attached to webs

Definition statement

This place covers:

Illustrative example of subject matter classified in this group:

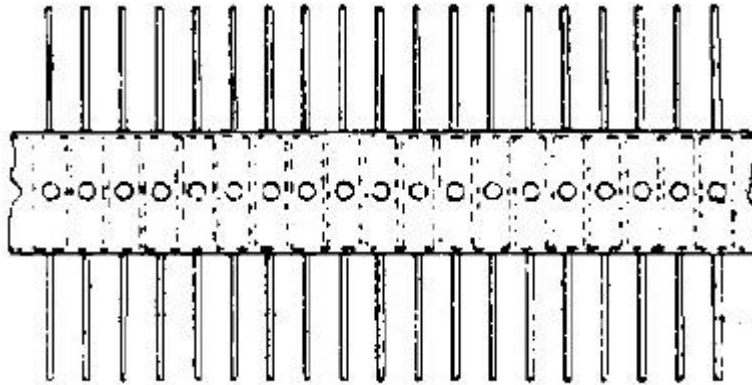

References

Limiting references

This place does not cover:

Strips of nails, screws, easily separable	F16B 15/00 , F16B 27/00
---	---

Informative references

Attention is drawn to the following places, which may be of interest for search:

Attaching a series of articles, e.g. small electrical components, to a continuous web	B65B 15/04
Placing of electric components on belts holding the terminals	H05K 13/003

B65D 75/00

Packages comprising articles or materials partially or wholly enclosed in strips, sheets, blanks, tubes, or webs of flexible sheet material, e.g. in folded wrappers ([B65D 71/00](#) takes precedence; wrapping [B65B 11/00](#))

References

Limiting references

This place does not cover:

Holders or wrappers as eating aids for fast food, e.g. hamburgers	A47G 21/001
---	-----------------------------

Special rules of classification

The use of available Indexing Codes is mandatory.

B65D 75/002

{in shrink films ([B65D 71/08](#) takes precedence)}

Definition statement

This place covers:

Illustrative example of subject matter classified in this group:

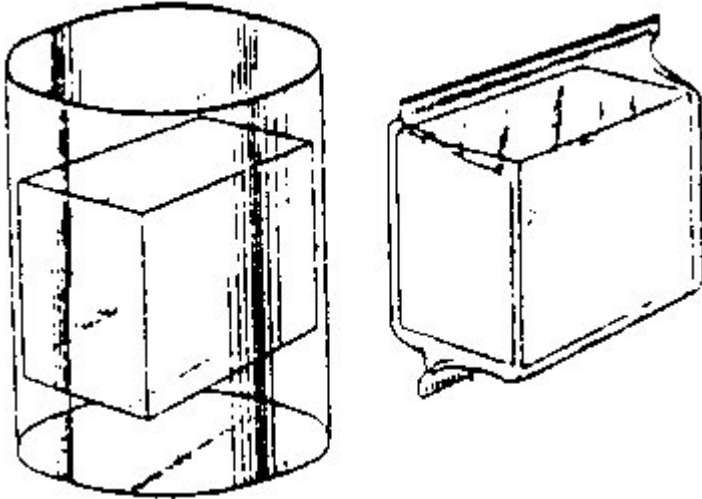
**References****Limiting references**

This place does not cover:

Wrappers shrunk by heat	B65D 71/08
-------------------------	----------------------------

Informative references

Attention is drawn to the following places, which may be of interest for search:

Coverings for bottles	B65D 23/0878
Packaging elements holding or encircling completely or almost completely the bundle of articles, e.g. wrappers	B65D 71/06
Laminates	B32B
Composition of the film	C08J
Labels to be fastened or secured by the material of the label itself, e.g. by thermos-adhesion	G09F 3/04

Special rules of classification

The use of available Indexing Codes is mandatory.

B65D 75/004**{with auxiliary packaging elements, e.g. protective pads or frames, trays}****References****Informative references***Attention is drawn to the following places, which may be of interest for search:*

Wrappers formed by one or more films or the like and provided with inserts	B65D 71/066
Wrappers shrunk by heat and provided with inserts	B65D 71/10

Special rules of classification

The use of available Indexing Codes is mandatory.

B65D 75/006**{in stretch films}****References****Limiting references***This place does not cover:*

Coverings for bottles	B65D 23/0878
Laminates	B32B
Composition of the film	C08J
Labels to be fastened or secured by the material of the label itself, e.g. by thermo-adhesion	G09F 3/04

Informative references*Attention is drawn to the following places, which may be of interest for search:*

Packaging elements holding or encircling completely or almost completely the bundle of articles, e.g. wrappers	B65D 71/06
Wrappers shrunk by heat	B65D 71/08

Special rules of classification

The use of available Indexing Codes is mandatory.

B65D 75/008**{Standing pouches, i.e. "Standbeutel"}****Definition statement***This place covers:*

Illustrative example of subject matter classified in this group:

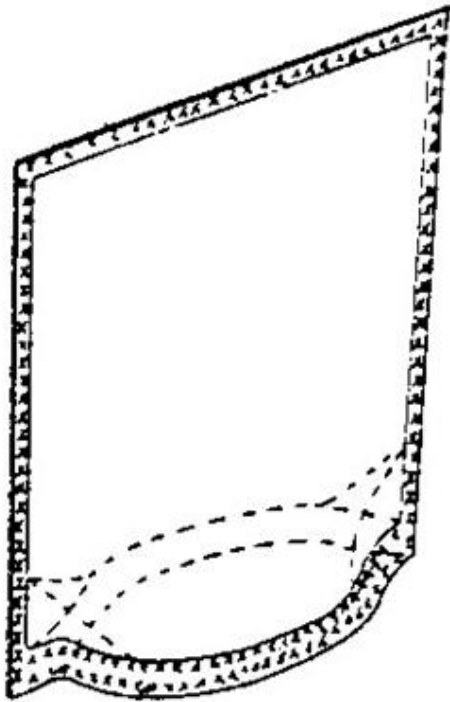
**References****Limiting references***This place does not cover:*

Handles for standing pouches	B65D 33/06 , B65D 75/56
Contents removing means for standing pouches	B65D 75/58

Informative references*Attention is drawn to the following places, which may be of interest for search:*

Bags or like containers made of paper and having structural provision for thickness of contents with rigid end walls	B65D 31/06
--	----------------------------

Special rules of classification

The use of available Indexing Codes is mandatory.

B65D 75/02

Articles partially enclosed in folded or wound strips or sheets, e.g. wrapped newspapers

Definition statement

This place covers:

Illustrative example of subject matter classified in this group:

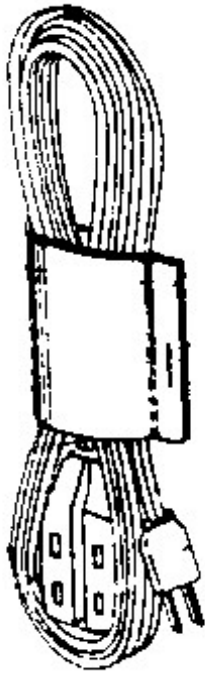
**References****Limiting references**

This place does not cover:

Comprising a plurality of articles held together only partially by packaging elements formed otherwise than by folding a blank	B65D 71/50
--	----------------------------

Special rules of classification

The use of available Indexing Codes is mandatory.

B65D 75/08

with the ends of the tube closed by folding

Definition statement

This place covers:

Illustrative example of subject matter classified in this group:

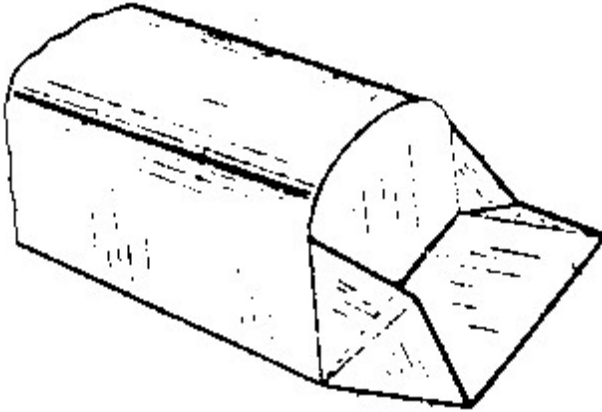

Special rules of classification

The use of available Indexing Codes is mandatory.

B65D 75/10

with the ends of the tube closed by twisting

Definition statement

This place covers:

Illustrative example of subject matter classified in this group:

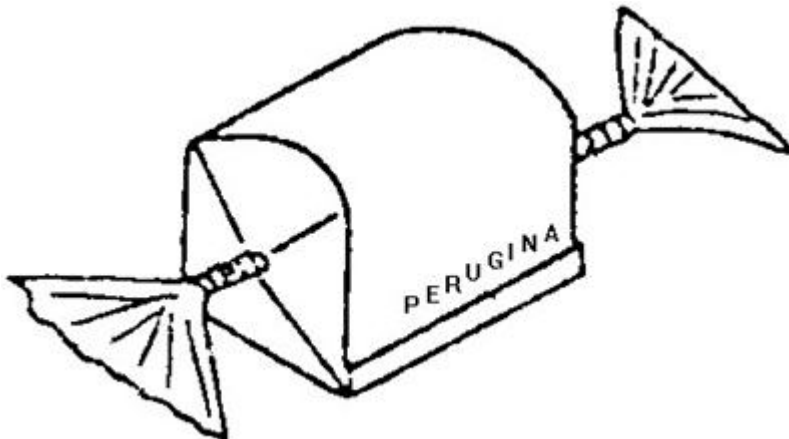

Special rules of classification

The use of available Indexing Codes is mandatory.

B65D 75/12

with the ends of the tube closed by flattening and heat-sealing

Definition statement

This place covers:

Illustrative example of subject matter classified in this group:

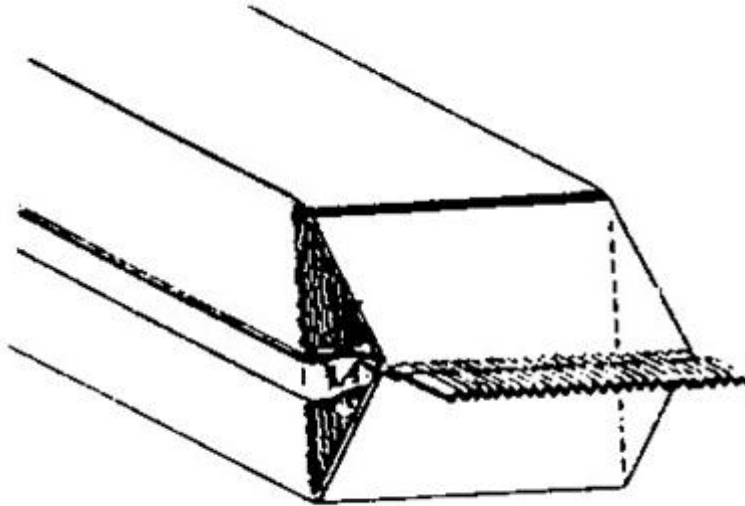

Special rules of classification

The use of available Indexing Codes is mandatory.

B65D 75/14

in sheets or blanks folded-up around all sides of the contents from a portion on which the contents are placed

Definition statement

This place covers:

Illustrative example of subject matter classified in this group:

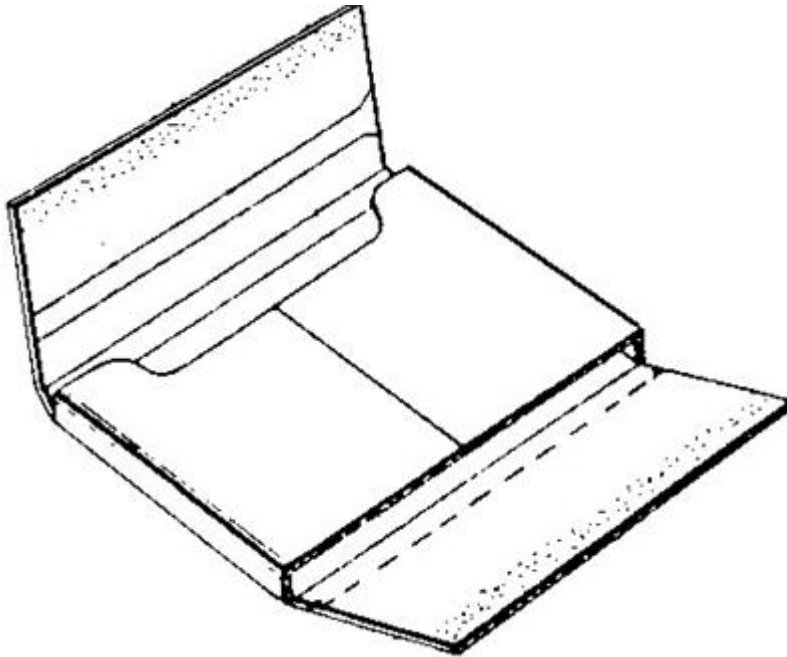

References

Informative references

Attention is drawn to the following places, which may be of interest for search:

Containers of polygonal cross-section characterised by integral closure-flaps	B65D 5/2052
---	-----------------------------

Special rules of classification

The use of available Indexing Codes is mandatory.

B65D 75/16

the upstanding portion of the wrapper being closed by twisting

Definition statement

This place covers:

Illustrative example of subject matter classified in this group:

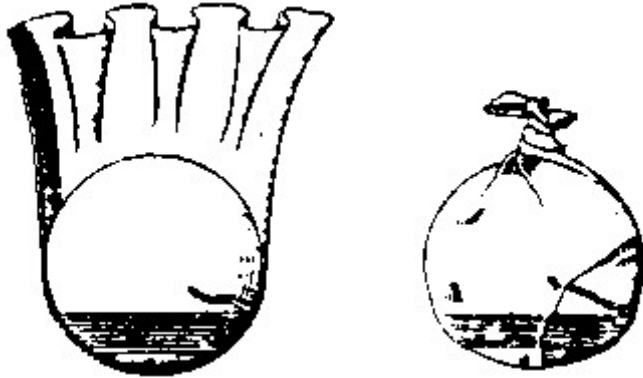

Special rules of classification

The use of available Indexing Codes is mandatory.

B65D 75/18

the upstanding portion of the wrapper being closed by regular or irregular folds or pleats, e.g. bunch-wrapped packages

Definition statement

This place covers:

Illustrative example of subject matter classified in this group:

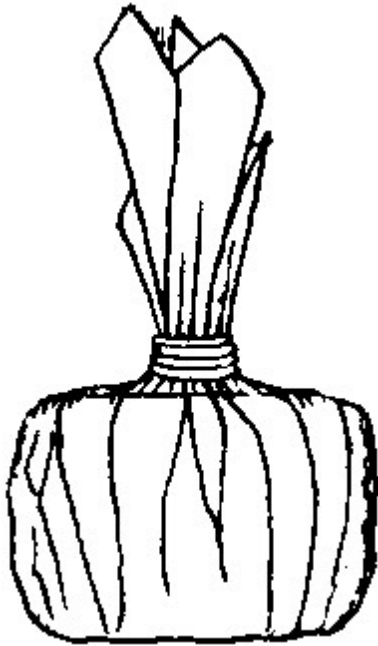

Special rules of classification

The use of available Indexing Codes is mandatory.

B65D 75/20

in sheets or blanks doubled around contents and having their opposed free margins united, e.g. by pressure-sensitive adhesive, crimping, heat-sealing, or welding

Definition statement

This place covers:

Illustrative example of subject matter classified in this group:

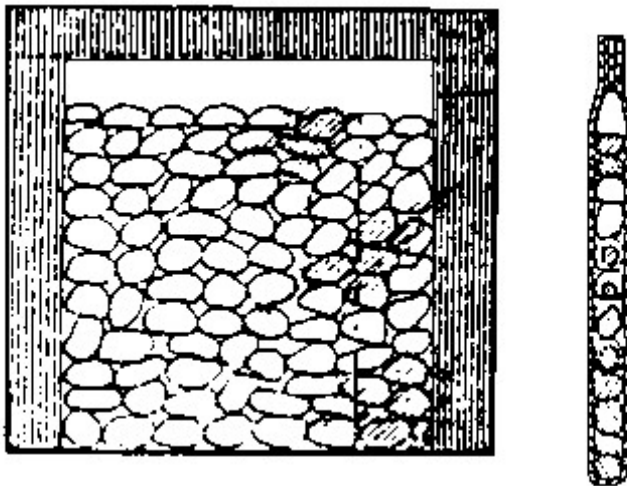
**References****Limiting references**

This place does not cover:

Records	B65D 85/546
---------	-----------------------------

Special rules of classification

The use of available Indexing Codes is mandatory.

B65D 75/22

the sheet or blank being recessed to accommodate contents {(containers simulating a book [B65D 77/006](#))}

Definition statement

This place covers:

Illustrative example of subject matter classified in this group:

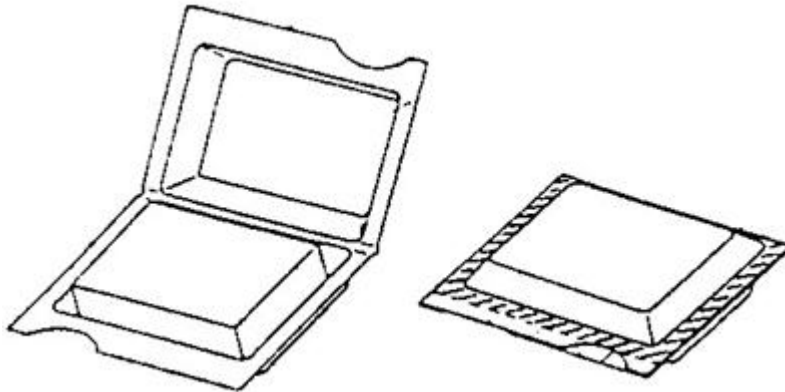
**References****Informative references**

Attention is drawn to the following places, which may be of interest for search:

Non-removable lids or covers - the container, the lid and the hinge being made of one piece	B65D 43/162
---	-----------------------------

Special rules of classification

The use of available Indexing Codes is mandatory.

B65D 75/225

{the sheet or blank comprising more than one fold line ([B65D 75/245](#) takes precedence)}

Definition statement

This place covers:

Illustrative example of subject matter classified in this group:

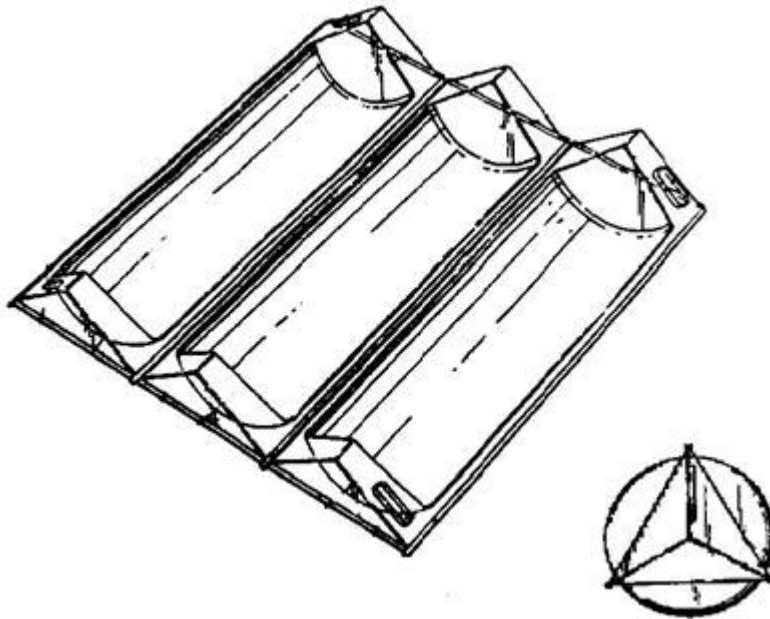
**References****Limiting references**

This place does not cover:

And formed with several recesses to accommodate a series of articles or quantities of material	B65D 75/245
--	-----------------------------

Special rules of classification

The use of available Indexing Codes is mandatory.

B65D 75/24

and formed with several recesses to accommodate a series of articles or quantities of material

Definition statement

This place covers:

Illustrative example of subject matter classified in this group:

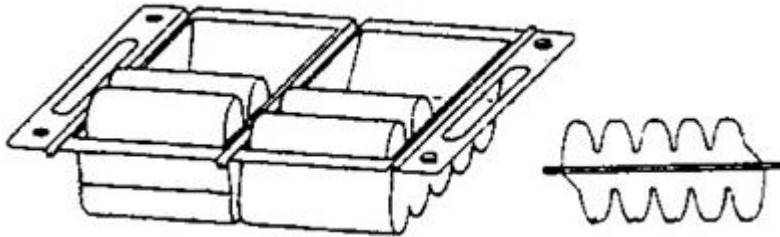
**Special rules of classification**

The use of available Indexing Codes is mandatory.

B65D 75/245

{the sheet or blank comprising more than one fold line}

Definition statement

This place covers:

Illustrative example of subject matter classified in this group:

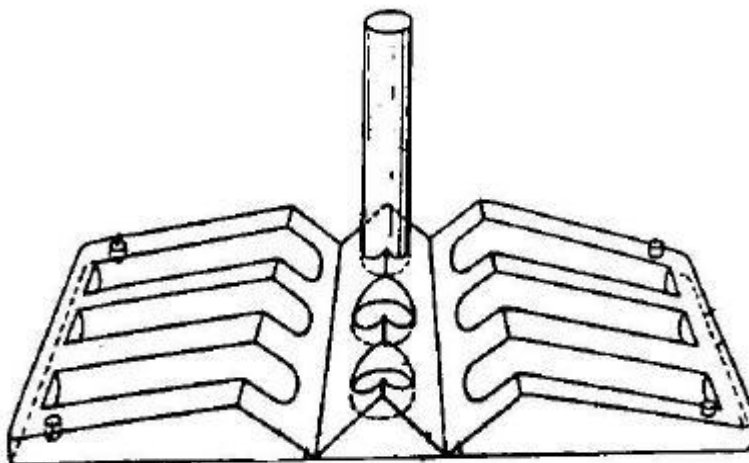
**Special rules of classification**

The use of available Indexing Codes is mandatory.

B65D 75/26

Articles or materials wholly enclosed in laminated sheets or wrapper blanks

Definition statement

This place covers:

Illustrative example of subject matter classified in this group:

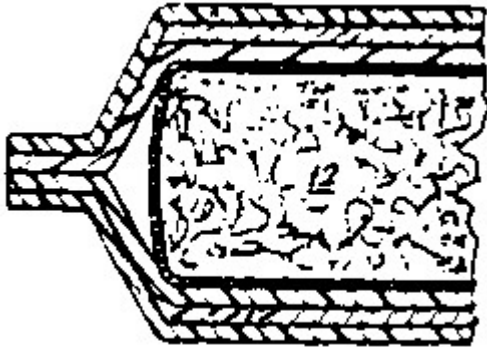
**Special rules of classification**

The use of available Indexing Codes is mandatory.

B65D 75/28

Articles or materials wholly enclosed in composite wrappers, i.e. wrappers formed by associating or interconnecting two or more sheets or blanks

Definition statement

This place covers:

Illustrative example of subject matter classified in this group:

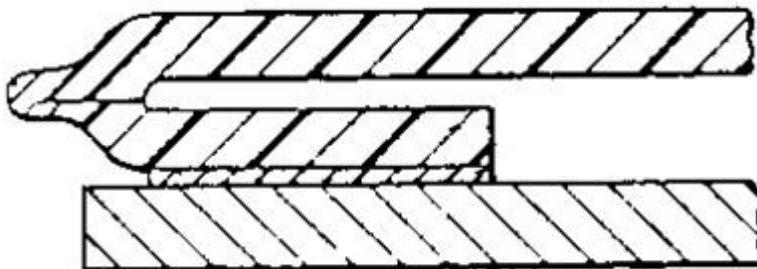
**References****Limiting references**

This place does not cover:

Two tubular sheets, the axes thereof being arranged perpendicularly to each other	B65D 75/38
Records	B65D 85/548

Special rules of classification

The use of available Indexing Codes is mandatory.

B65D 75/30

Articles or materials enclosed between two opposed sheets or blanks having their margins united, e.g. by pressure-sensitive adhesive, crimping, heat-sealing, or welding

Definition statement

This place covers:

Illustrative example of subject matter classified in this group:

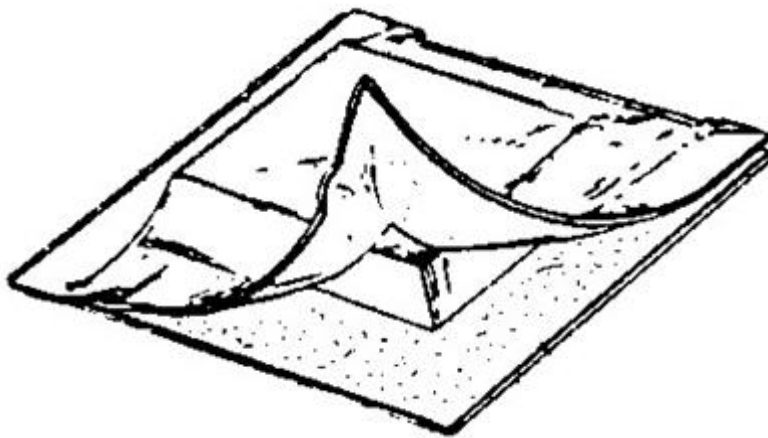
**Special rules of classification**

The use of available Indexing Codes is mandatory.

B65D 75/305

{Skin packages}

Definition statement

This place covers:

Illustrative example of subject matter classified in this group:

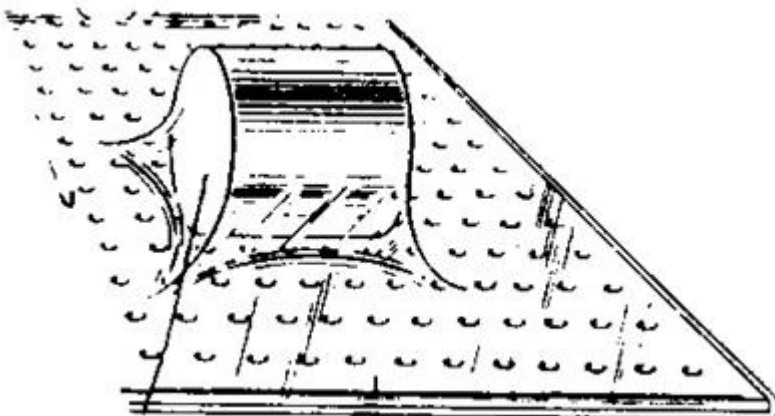

References

Limiting references

This place does not cover:

Articles attached to cards by means of a preformed enclosure	B65D 73/0057 , B65D 73/0092
--	--

Special rules of classification

The use of available Indexing Codes is mandatory.

B65D 75/32

one or both sheets or blanks being recessed to accommodate contents

References

Limiting references

This place does not cover:

Freezing trays for ice-cubes	F25C 1/243
------------------------------	----------------------------

Special rules of classification

The use of available Indexing Codes is mandatory.

B65D 75/322

{and forming one compartment}

Definition statement

This place covers:

Illustrative example of subject matter classified in this group:

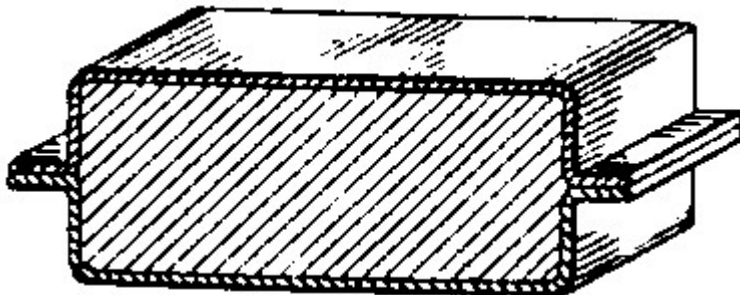

Special rules of classification

The use of available Indexing Codes is mandatory.

B65D 75/323**{and forming several compartments}****Definition statement***This place covers:*

Illustrative example of subject matter classified in this group:

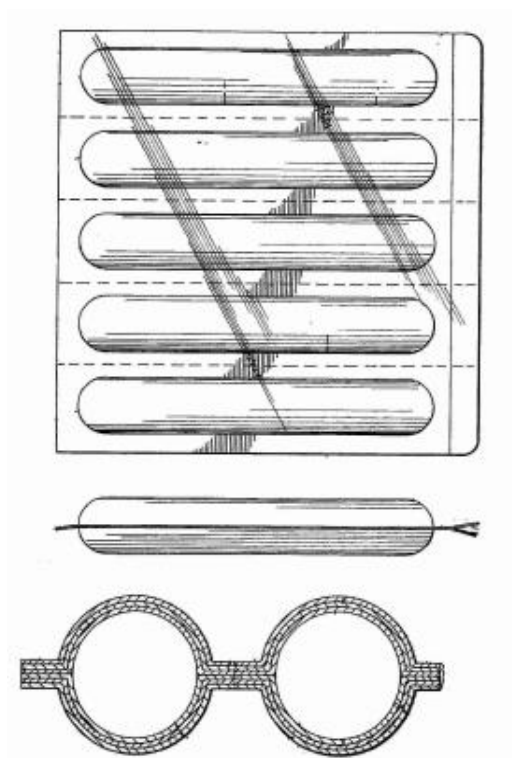
**References****Limiting references***This place does not cover:*

Blister-type containers for medical or pharmaceutical purposes	A61J 1/035
Tools for removing pills or other small items out of blister packs	B65B 69/00

Informative references*Attention is drawn to the following places, which may be of interest for search:*

Thermoformed trays or the like with a plurality of recesses for different materials located in different recesses	B65D 81/3294
---	------------------------------

Special rules of classification

The use of available Indexing Codes is mandatory.

B65D 75/324

{the compartments being interconnected, e.g. by small channels}

Definition statement

This place covers:

Illustrative example of subject matter classified in this group:

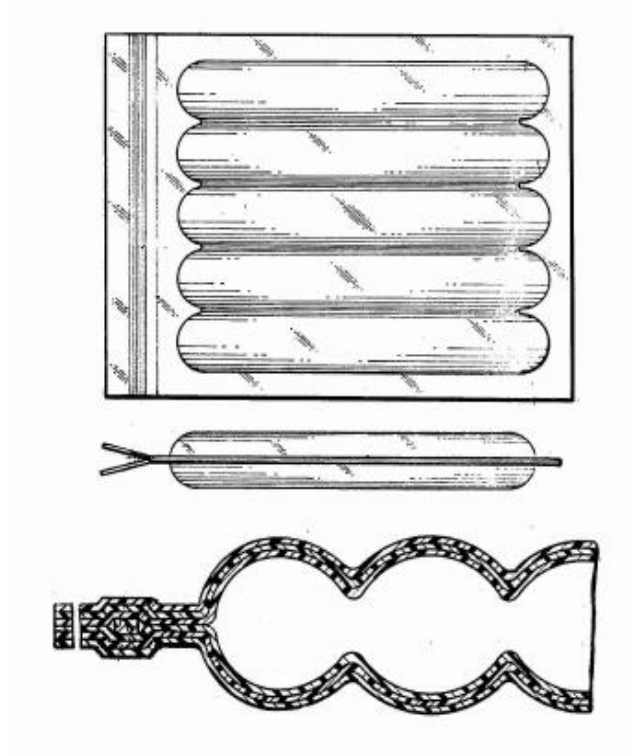

Special rules of classification

The use of available Indexing Codes is mandatory.

B65D 75/326

{and forming one compartment}

Definition statement

This place covers:

Illustrative example of subject matter classified in this group:

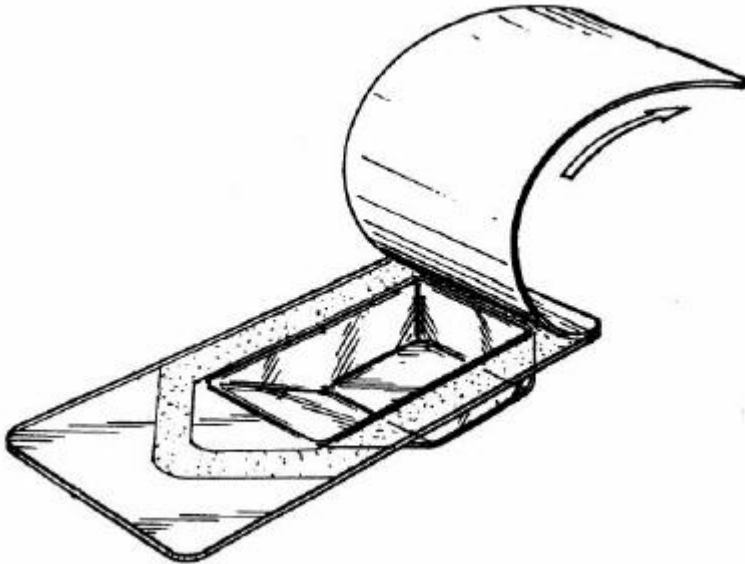

Special rules of classification

The use of available Indexing Codes is mandatory.

B65D 75/327

{and forming several compartments}

Definition statement

This place covers:

Illustrative example of subject matter classified in this group:

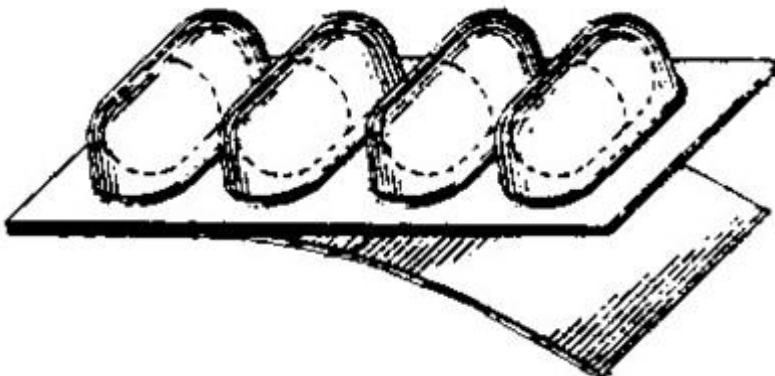

References

Limiting references

This place does not cover:

Blister-type containers for medical or pharmaceutical purposes	A61J 1/035
Tools for removing pills or other small items out of blister packs	B65B 69/00

Informative references

Attention is drawn to the following places, which may be of interest for search:

Thermoformed trays or the like with a plurality of recesses for different materials located in different recesses	B65D 81/3294
---	------------------------------

Special rules of classification

The use of available Indexing Codes is mandatory.

B65D 75/328

{the compartments being interconnected, e.g. by small channels}

Definition statement

This place covers:

Illustrative example of subject matter classified in this group:

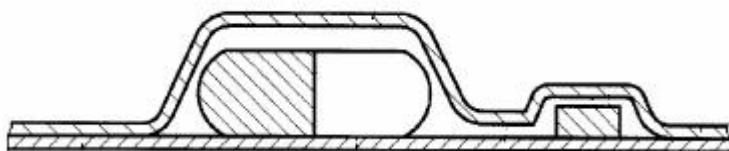

Special rules of classification

The use of available Indexing Codes is mandatory.

B65D 75/34

and having several recesses to accommodate a series of articles or quantities of material {(not used)}

References

Limiting references

This place does not cover:

Blister-type containers for medical or pharmaceutical purposes	A61J 1/035
--	----------------------------

Informative references

Attention is drawn to the following places, which may be of interest for search:

Thermoformed trays or the like with a plurality of recesses for different materials located in different recesses	B65D 81/3294
---	------------------------------

B65D 75/36

one sheet or blank being recessed and the other formed of relatively stiff flat sheet material, e.g. blister packages {, the recess or recesses being preformed ([B65D 73/0057](#), [B65D 73/0092](#) take precedence)}

References**Limiting references**

This place does not cover:

Illustrative example of subject matter classified in this group:

Blister-type containers for medical or pharmaceutical purposes	A61J 1/035
Tools for removing pills or other small items out of blister packs	B65B 69/00

Special rules of classification

The use of available Indexing Codes is mandatory.

B65D 75/366

{and forming one compartment}

Definition statement

This place covers:

Illustrative example of subject matter classified in this group:

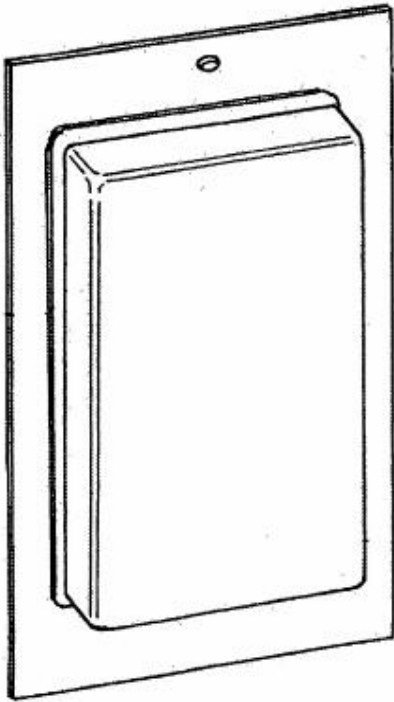

Special rules of classification

The use of available Indexing Codes is mandatory.

B65D 75/367**{and forming several compartments}****Definition statement***This place covers:*

Illustrative example of subject matter classified in this group:

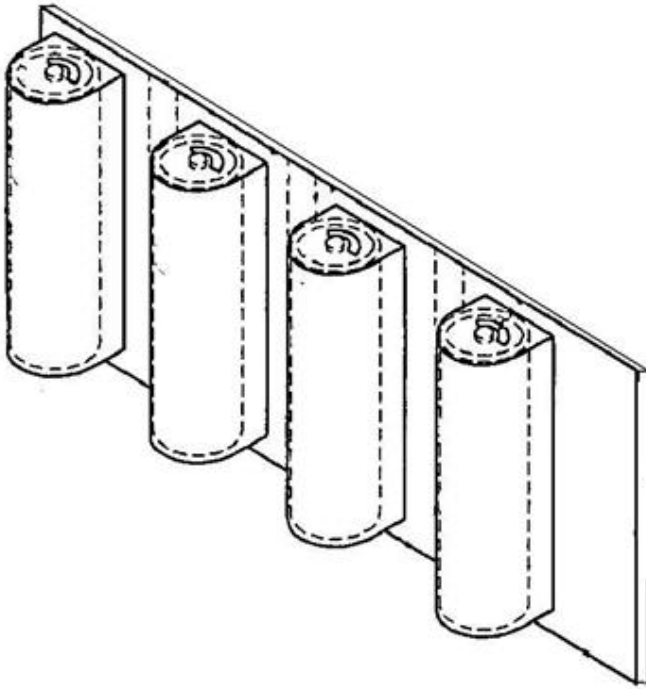
**References****Limiting references***This place does not cover:*

Blister-type containers for medical or pharmaceutical purposes	A61J 1/035
Tools for removing pills or other small items out of blister packs	B65B 69/00

Informative references*Attention is drawn to the following places, which may be of interest for search:*

Thermoformed trays or the like with a plurality of recesses for different materials located in different recesses	B65D 81/3294
---	------------------------------

Special rules of classification

The use of available Indexing Codes is mandatory.

B65D 75/368

{the compartments being interconnected, e.g. by small channels}

Definition statement

This place covers:

Illustrative example of subject matter classified in this group:

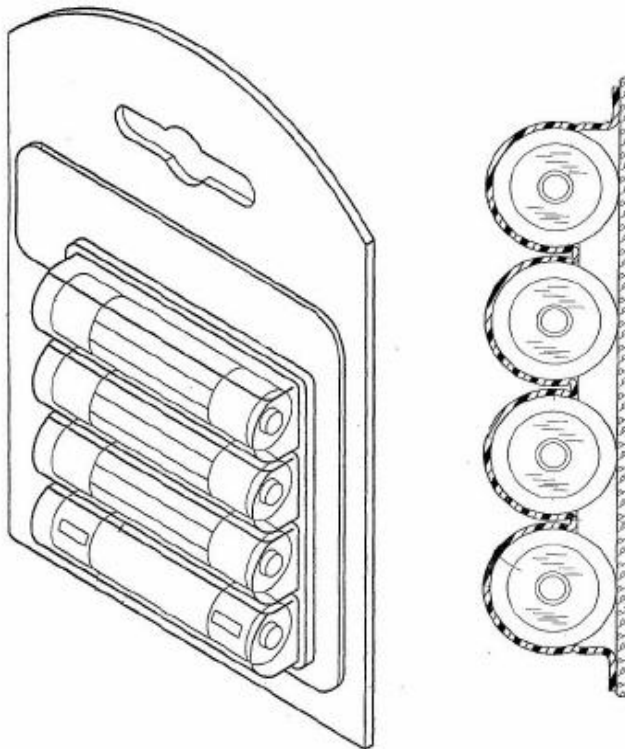
**Special rules of classification**

The use of available Indexing Codes is mandatory.

B65D 75/38

Articles or materials enclosed in two or more wrappers disposed one inside the other {(for shock absorbing purposes [B65D 81/03](#); for thermal insulating purposes [B65D 81/3893](#))}

Definition statement

This place covers:

Illustrative example of subject matter classified in this group:

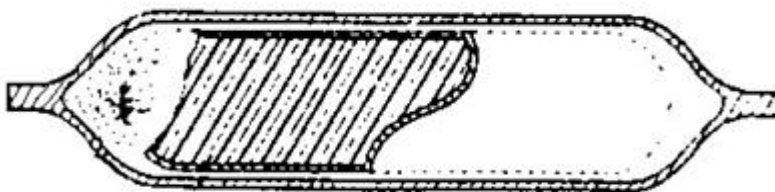

References

Limiting references

This place does not cover:

Two tubular sheets, the axes thereof being arranged perpendicularly to each other	B65D 75/28
---	----------------------------

Informative references

Attention is drawn to the following places, which may be of interest for search:

Articles or materials enclosed in two or more containers disposed one within another	B65D 77/04
--	----------------------------

Special rules of classification

The use of available Indexing Codes is mandatory.

B65D 75/40

Packages formed by enclosing successive articles, or increments of material, in webs, e.g. folded or tubular webs, or by subdividing tubes filled with liquid, semi-liquid, or plastic materials

Definition statement

This place covers:

Illustrative example of subject matter classified in this group:

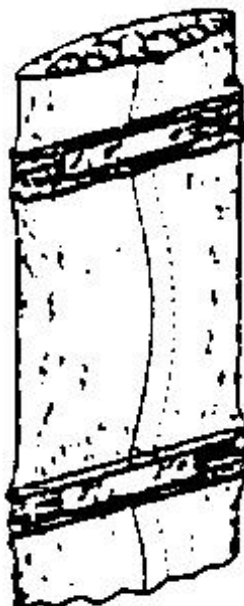

Special rules of classification

The use of available Indexing Codes is mandatory.

B65D 75/42

Chains of interconnected packages

Definition statement

This place covers:

Illustrative example of subject matter classified in this group:

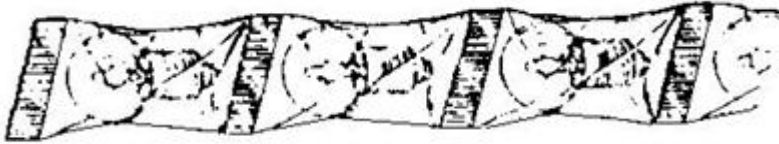

Special rules of classification

The use of available Indexing Codes is mandatory.

B65D 75/44

Individual packages cut from webs or tubes

Definition statement

This place covers:

Illustrative example of subject matter classified in this group:

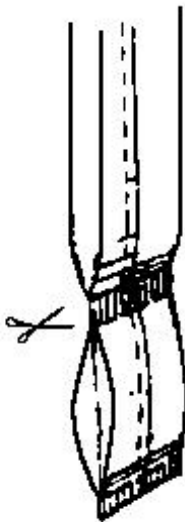

Special rules of classification

The use of available Indexing Codes is mandatory.

B65D 75/46

containing articles

Definition statement

This place covers:

Illustrative example of subject matter classified in this group:

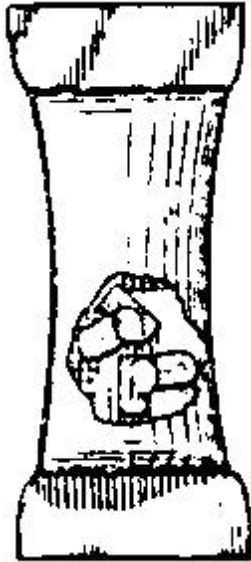

Special rules of classification

The use of available Indexing Codes is mandatory.

B65D 75/48

containing liquids, semiliquids, or pastes, e.g. cushion-shaped packages

Definition statement

This place covers:

Illustrative example of subject matter classified in this group:

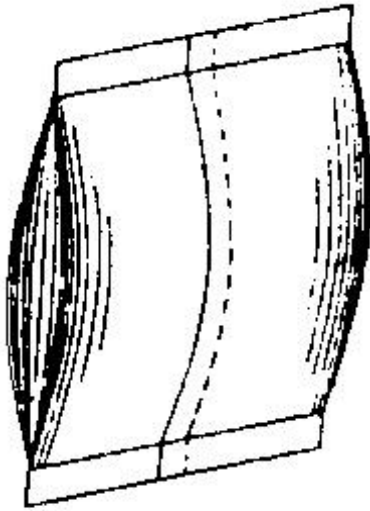

References

Informative references

Attention is drawn to the following places, which may be of interest for search:

Containers, packaging elements, or packages using pillow-like elements filled with fluid	B65D 81/052
--	-----------------------------

Special rules of classification

The use of available Indexing Codes is mandatory.

B65D 75/50

Tetrahedral packages

Definition statement

This place covers:

Illustrative example of subject matter classified in this group:

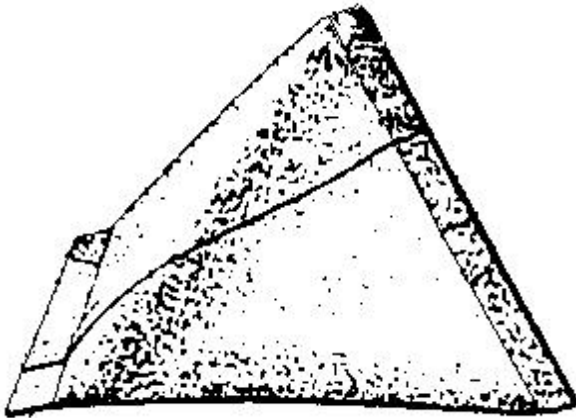

References

Limiting references

This place does not cover:

Packages for tetrahedral packages	B65D 85/542
-----------------------------------	-----------------------------

Special rules of classification

The use of available Indexing Codes is mandatory.

B65D 75/52

Details

References

Limiting references

This place does not cover:

Flexible valves, e.g. pressure-relief valves	B65D 77/225
--	-----------------------------

Special rules of classification

The use of available Indexing Codes is mandatory.

B65D 75/522**{Inspection openings or windows}****Definition statement***This place covers:*

Illustrative example of subject matter classified in this group:

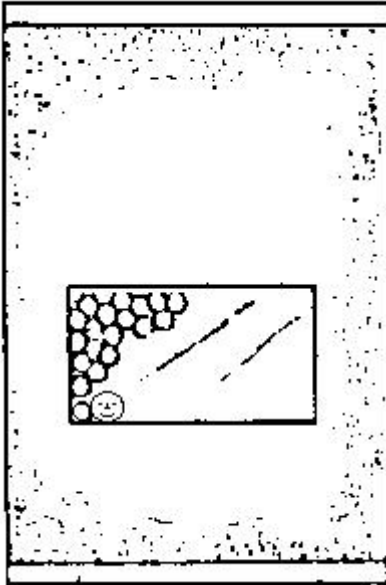
**References****Informative references***Attention is drawn to the following places, which may be of interest for search:*

Windows or other apertures, e.g. for viewing contents	B65D 33/04
Wrappers or flexible covers with some areas transparent and others opaque	B65D 65/18
Means or constructions for testing or controlling the contents	B65D 2201/00

Special rules of classification

The use of available Indexing Codes is mandatory.

B65D 75/525**{External rigid or semi-rigid supports}****Definition statement***This place covers:*

Illustrative example of subject matter classified in this group:

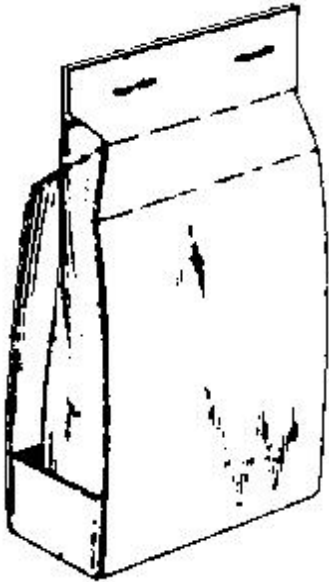
**References*****Informative references****Attention is drawn to the following places, which may be of interest for search:*

Bags or like containers made of paper and having structural provision for thickness of contents	B65D 31/00
Details of, or accessories for, sacks or bags	B65D 33/00

Special rules of classification

The use of available Indexing Codes is mandatory.

B65D 75/527

{Tear-lines for separating a package into individual packages ([B65D 1/30](#), [B65D 21/0206](#), [B65D 75/34](#) take precedence)}

Definition statement

This place covers:

Illustrative example of subject matter classified in this group:

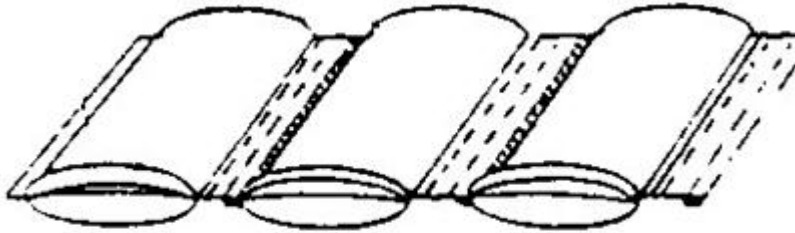
**References****Informative references**

Attention is drawn to the following places, which may be of interest for search:

Groups of containers joined together end-to-end or side-by-side	B65D 1/30
Separate rigid or semi-rigid trays or cups joined together	B65D 21/0206
Articles or materials wholly enclosed in composite wrappers and having several recesses to accommodate a series of articles or quantities of material	B65D 75/34
Tear-lines for removing successive sections of a package	B65D 75/5888

Special rules of classification

The use of available Indexing Codes is mandatory.

B65D 75/54

Cards, coupons, or other inserts or accessories (opening devices [B65D 75/70](#))

References**Limiting references**

This place does not cover:

Information or decoration elements, e.g. content indicators	B65D 5/4212
Means for the attachment of smaller articles of tags	B65D 23/14
Means for the attachment of labels, cards, coupons or the like	B65D 25/205
Information or decoration elements, e.g. level indicators, detachable tabs or coupons	B65D 33/004
Drinking straws incorporated in or attached to containers	B65D 77/28

Informative references

Attention is drawn to the following places, which may be of interest for search:

Containers of polygonal cross-section the container body comprising a set of interconnected cells	B65D 5/009
Means for the attachment of smaller articles of tags	B65D 23/14
Means for the attachment of labels, cards, coupons or the like	B65D 25/205
Information or decoration elements, e.g. level indicators, detachable tabs or coupons	B65D 33/004
Tear-lines for removing successive sections of a package	B65D 75/5888

Special rules of classification

The use of available Indexing Codes is mandatory.

B65D 75/545

{the inserts or accessories being located within a pouch or envelope attached to the exterior of the packages, e.g. shipping mailers (envelope construction [B65D 27/00](#))}

Definition statement

This place covers:

Illustrative example of subject matter classified in this group:

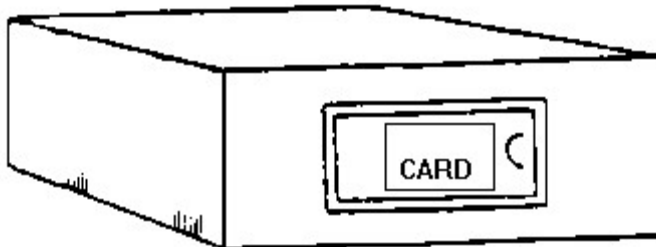
**Special rules of classification**

The use of available Indexing Codes is mandatory.

B65D 75/56**Handles or other suspension means****Definition statement**

This place covers:

Illustrative example of subject matter classified in this group:

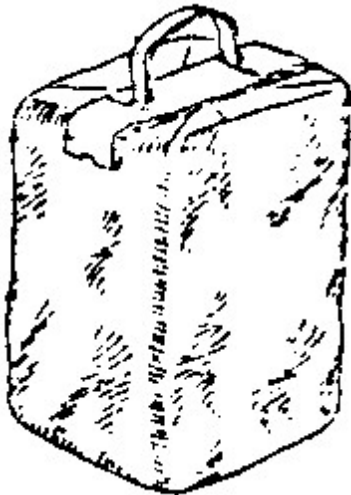
**References****Limiting references**

This place does not cover:

Loose handles for carrying purposes	A45F 5/10
-------------------------------------	---------------------------

Informative references

Attention is drawn to the following places, which may be of interest for search:

External fittings for facilitating lifting or suspending of containers	B65D 25/22
Handles	B65D 33/06
Elements provided with handles or other suspension means	B65D 63/18

Special rules of classification

The use of available Indexing Codes is mandatory.

B65D 75/563

{Integral handles or suspension means ([B65D 75/566](#) takes precedence)}

Definition statement

This place covers:

Illustrative example of subject matter classified in this group:

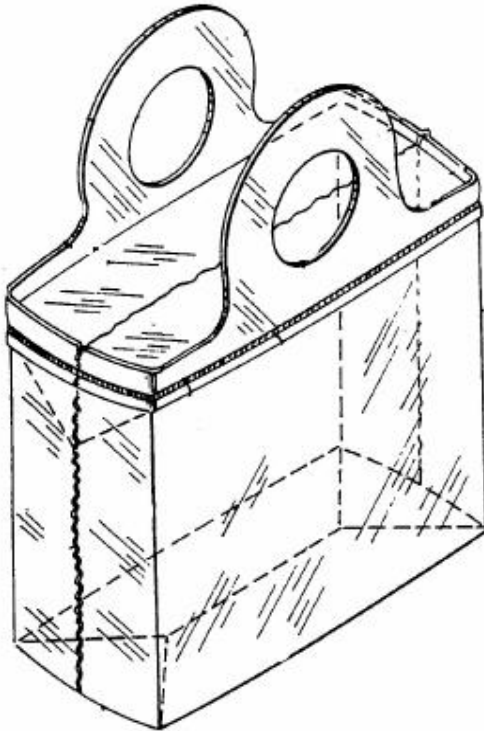
**References****Limiting references**

This place does not cover:

Hand holes or suspension apertures	B65D 75/566
------------------------------------	-----------------------------

Special rules of classification

The use of available Indexing Codes is mandatory.

B65D 75/566**{Hand holes or suspension apertures}****Definition statement***This place covers:*

Illustrative example of subject matter classified in this group:

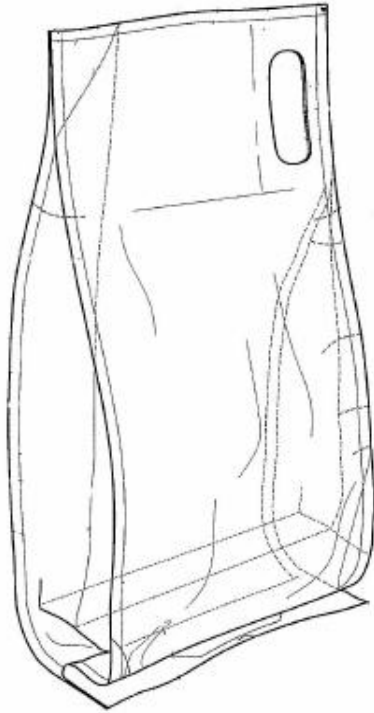
**Special rules of classification**

The use of available Indexing Codes is mandatory.

B65D 75/58**Opening or contents-removing devices added or incorporated during package manufacture {([B65D 75/36](#), [B65D 85/1027](#) take precedence)}****References****Limiting references***This place does not cover:*

Articles or materials enclosed between two opposed sheets or blanks having their margins united, one sheet or blank being recessed and the other formed of relatively stiff flat sheet material	B65D 75/36
Opening devices	B65D 85/1027

Informative references

Attention is drawn to the following places, which may be of interest for search:

Packages formed by enclosing successive articles, or increments of material, in webs, e.g. folded or tubular webs, or by subdividing tubes filled with liquid, semi-liquid, or plastic materials	B65D 75/40 - B65D 75/50
--	---

Special rules of classification

The use of available Indexing Codes is mandatory.

B65D 75/5805

{for tearing a side strip parallel and next to the edge, e.g. by means of a line of weakness}

Definition statement

This place covers:

Illustrative example of subject matter classified in this group:

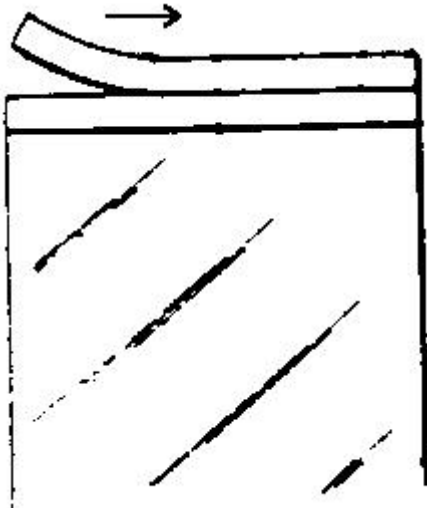
**References****Informative references**

Attention is drawn to the following places, which may be of interest for search:

Packages formed by enclosing successive articles, or increments of material, in webs, e.g. folded or tubular webs, or by subdividing tubes filled with liquid, semi-liquid, or plastic materials	B65D 75/40 - B65D 75/50
--	---

Special rules of classification

The use of available Indexing Codes is mandatory.

B65D 75/5811

{and defining, after tearing, a small dispensing spout, a small orifice or the like}

Definition statement

This place covers:

Illustrative example of subject matter classified in this group:

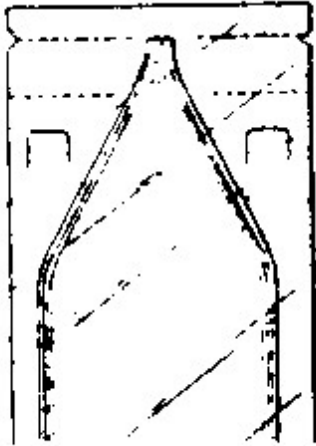
**References****Informative references**

Attention is drawn to the following places, which may be of interest for search:

Packages formed by enclosing successive articles, or increments of material, in webs, e.g. folded or tubular webs, or by subdividing tubes filled with liquid, semi-liquid, or plastic materials	B65D 75/40 - B65D 75/50
For tearing a corner or other small portion next to the edge and defining a small dispensing spout, a small orifice or the like	B65D 75/5822
Integral spouts	B65D 75/5866

Special rules of classification

The use of available Indexing Codes is mandatory.

B65D 75/5816

{for tearing a corner or other small portion next to the edge, e.g. a U-shaped portion}

Definition statement

This place covers:

Illustrative example of subject matter classified in this group:

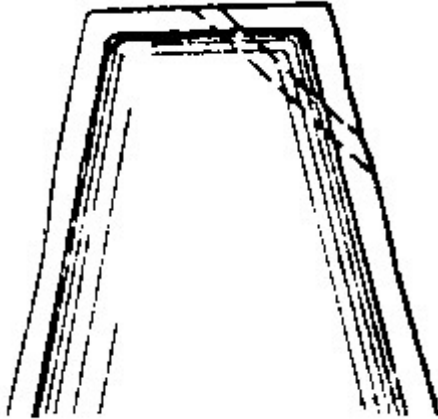
**References*****Informative references***

Attention is drawn to the following places, which may be of interest for search:

Packages formed by enclosing successive articles, or increments of material, in webs, e.g. folded or tubular webs, or by subdividing tubes filled with liquid, semi-liquid, or plastic materials	B65D 75/40 - B65D 75/50
--	---

Special rules of classification

The use of available Indexing Codes is mandatory.

B65D 75/5822

{and defining, after tearing, a small dispensing spout, a small orifice or the like}

Definition statement

This place covers:

Illustrative example of subject matter classified in this group:

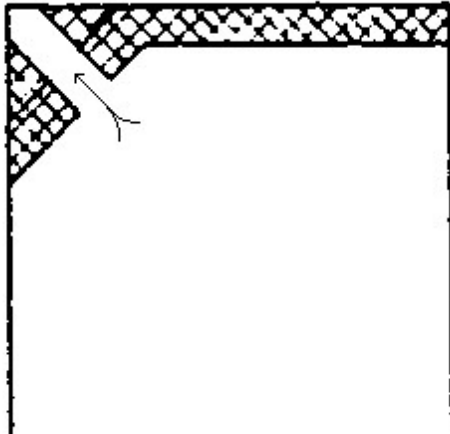
**References****Informative references**

Attention is drawn to the following places, which may be of interest for search:

Packages formed by enclosing successive articles, or increments of material, in webs, e.g. folded or tubular webs, or by subdividing tubes filled with liquid, semi-liquid, or plastic materials	B65D 75/40 - B65D 75/50
For tearing a side strip parallel and next to the edge, e.g. by means of a line of weakness and defining a small dispensing spout, a small orifice or the like	B65D 75/5811
Integral spouts	B65D 75/5866

Special rules of classification

The use of available Indexing Codes is mandatory.

B65D 75/5827

{Tear-lines provided in a wall portion ([B65D 75/5805](#), [B65D 75/5816](#) take precedence)}

Definition statement

This place covers:

Illustrative example of subject matter classified in this group:

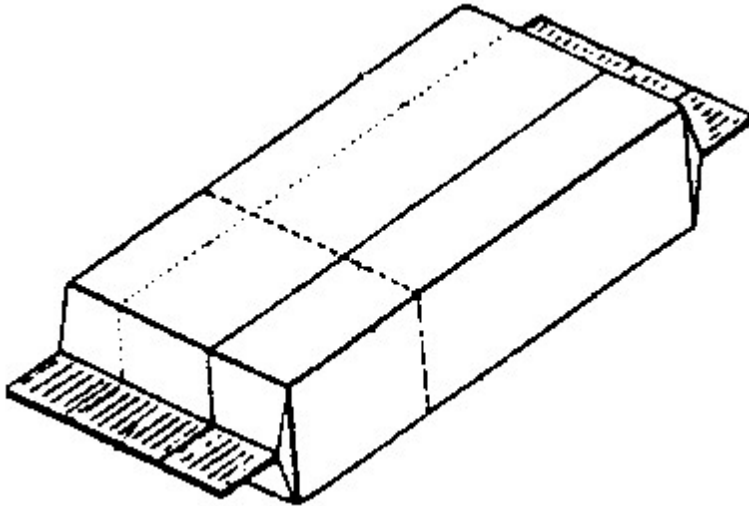
**References****Limiting references**

This place does not cover:

Opening or contents-removing devices added or incorporated during package manufacture for tearing a side strip parallel and next to the edge	B65D 75/5805
Opening or contents-removing devices added or incorporated during package manufacture, for tearing a corner or other small portion next to the edge	B65D 75/5816

Informative references

Attention is drawn to the following places, which may be of interest for search:

Packages formed by enclosing successive articles, or increments of material, in webs, e.g. folded or tubular webs, or by subdividing tubes filled with liquid, semi-liquid, or plastic materials	B65D 75/40 - B65D 75/50
--	---

Special rules of classification

The use of available Indexing Codes is mandatory.

B65D 75/5833**{for tearing out a portion of the wall}****Definition statement***This place covers:*

Illustrative example of subject matter classified in this group:

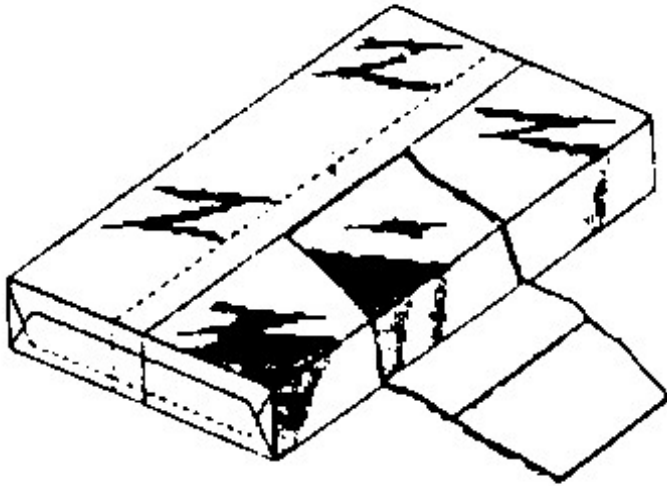
**References*****Informative references****Attention is drawn to the following places, which may be of interest for search:*

Packages formed by enclosing successive articles, or increments of material, in webs, e.g. folded or tubular webs, or by subdividing tubes filled with liquid, semi-liquid, or plastic materials	B65D 75/40 - B65D 75/50
--	---

Special rules of classification

The use of available Indexing Codes is mandatory.

B65D 75/5838

{combined with separate fixed tearing means, e.g. tabs}

Definition statement

This place covers:

Illustrative example of subject matter classified in this group:

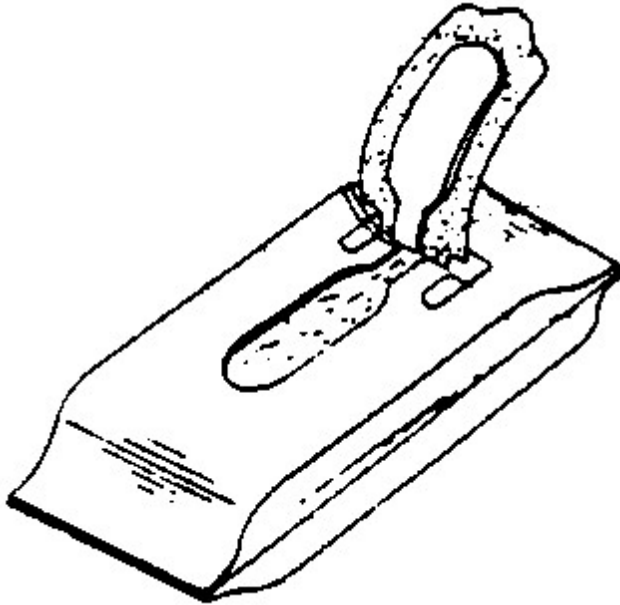

References

Informative references

Attention is drawn to the following places, which may be of interest for search:

Packages formed by enclosing successive articles, or increments of material, in webs, e.g. folded or tubular webs, or by subdividing tubes filled with liquid, semi-liquid, or plastic materials
--

B65D 75/40 - B65D 75/50

Special rules of classification

The use of available Indexing Codes is mandatory.

B65D 75/5844

{the portion of the wall being a narrow strip, e.g. between lines of weakness
([B65D 75/5838](#) takes precedence)}

Definition statement

This place covers:

Illustrative example of subject matter classified in this group:

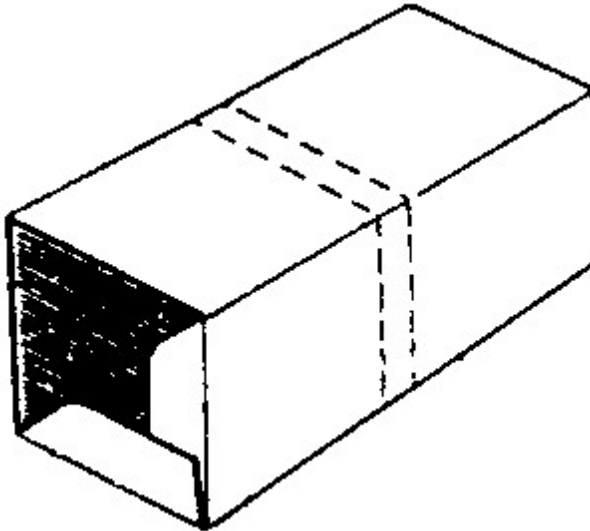
**References****Limiting references**

This place does not cover:

Tear-lines provided in a wall portion combined with separate fixed tearing means	B65D 75/5838
--	------------------------------

Informative references

Attention is drawn to the following places, which may be of interest for search:

Packages formed by enclosing successive articles, or increments of material, in webs, e.g. folded or tubular webs, or by subdividing tubes filled with liquid, semi-liquid, or plastic materials	B65D 75/40 - B65D 75/50
--	---

Special rules of classification

The use of available Indexing Codes is mandatory.

B65D 75/585

{the tear-lines being broken by deformation or bending}

Definition statement

This place covers:

Illustrative example of subject matter classified in this group:

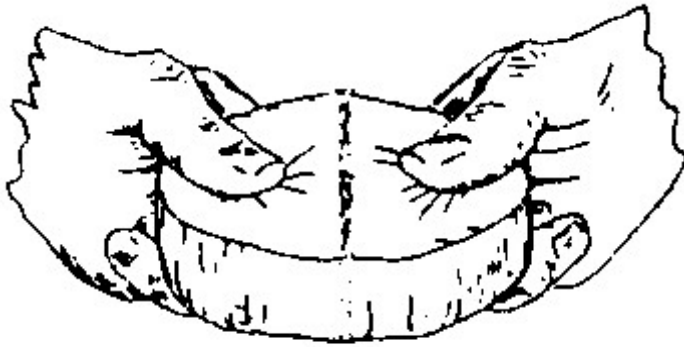
**References****Informative references**

Attention is drawn to the following places, which may be of interest for search:

Packages formed by enclosing successive articles, or increments of material, in webs, e.g. folded or tubular webs, or by subdividing tubes filled with liquid, semi-liquid, or plastic materials	B65D 75/40 - B65D 75/50
--	---

Special rules of classification

The use of available Indexing Codes is mandatory.

B65D 75/5855**{Peelable seals}****Definition statement***This place covers:*

Illustrative example of subject matter classified in this group:

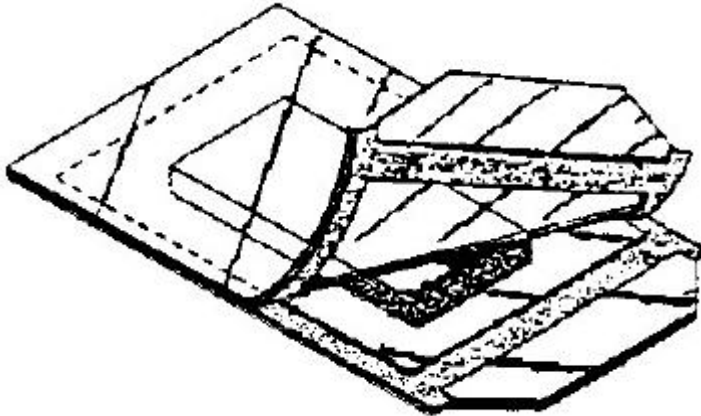
**References****Limiting references***This place does not cover:*

Making non-permanent or releasable joints	B29C 65/76
---	----------------------------

Informative references*Attention is drawn to the following places, which may be of interest for search:*

Packages formed by enclosing successive articles, or increments of material, in webs, e.g. folded or tubular webs, or by subdividing tubes filled with liquid, semi-liquid, or plastic materials	B65D 75/40 - B65D 75/50
--	---

Special rules of classification

The use of available Indexing Codes is mandatory.

B65D 75/5861**{Spouts ([B65D 75/5811](#), [B65D 75/5822](#) take precedence)}****References****Informative references***Attention is drawn to the following places, which may be of interest for search:*

Packages formed by enclosing successive articles, or increments of material, in webs, e.g. folded or tubular webs, or by subdividing tubes filled with liquid, semi-liquid, or plastic materials	B65D 75/40 - B65D 75/50
--	---

Flexible containers disposed within polygonal containers formed by folding a carton blank	B65D 77/062
---	-----------------------------

Special rules of classification

The use of available Indexing Codes is mandatory.

B65D 75/5866

{Integral spouts}

Definition statement

This place covers:

Illustrative example of subject matter classified in this group:

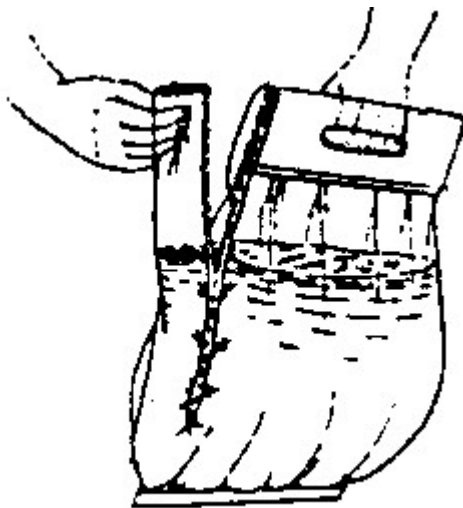

References

Informative references

Attention is drawn to the following places, which may be of interest for search:

Packages formed by enclosing successive articles, or increments of material, in webs, e.g. folded or tubular webs, or by subdividing tubes filled with liquid, semi-liquid, or plastic materials	B65D 75/40 - B65D 75/50
Opening or contents-removing devices for tearing a side strip parallel and next to the edge and defining, after tearing, a small dispensing spout, a small orifice or the like	B65D 75/5811
Opening or contents-removing devices for tearing a side strip parallel and next to the edge and defining, after tearing, a small dispensing spout, a small orifice or the like	B65D 75/5822
Spouts, pouring necks or discharging tubes fixed to or integral with the flexible container	B65D 77/065

Special rules of classification

The use of available Indexing Codes is mandatory.

B65D 75/5872

{Non-integral spouts}

References

Informative references

Attention is drawn to the following places, which may be of interest for search:

Spouts formed separately from the container	B65D 5/746
---	----------------------------

Special rules of classification

The use of available Indexing Codes is mandatory.

B65D 75/5877

{connected to a planar surface of the package wall}

Definition statement

This place covers:

Illustrative example of subject matter classified in this group:

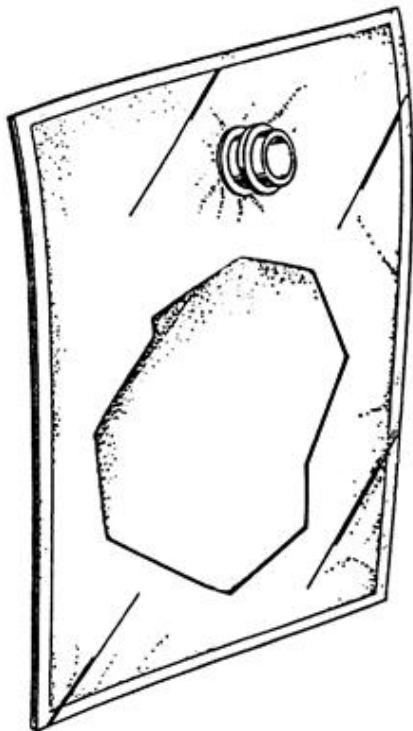

Special rules of classification

The use of available Indexing Codes is mandatory.

B65D 75/5883

{connected to the package at the sealed junction of two package walls}

Definition statement

This place covers:

Illustrative example of subject matter classified in this group:

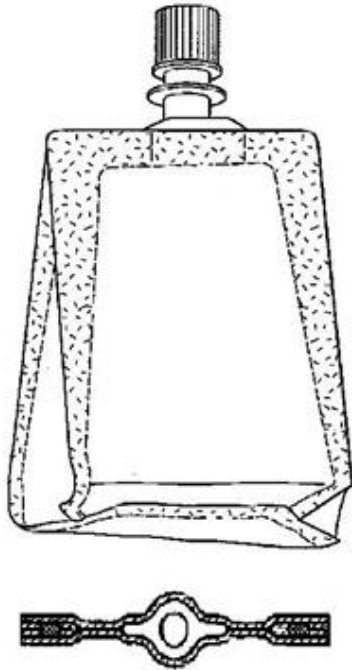
**Special rules of classification**

The use of available Indexing Codes is mandatory.

B65D 75/5888

{Tear-lines for removing successive sections of a package (for separating package into individual packages [B65D 75/527](#))}

Definition statement

This place covers:

Illustrative example of subject matter classified in this group:

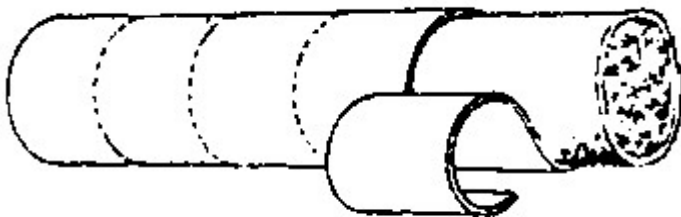

References

Informative references

Attention is drawn to the following places, which may be of interest for search:

Opening arrangements or devices incorporated in, or attached to, containers, forming a circumferential line of weakness	B65D 3/262
Packages formed by enclosing successive articles, or increments of material, in webs, e.g. folded or tubular webs, or by subdividing tubes filled with liquid, semi-liquid, or plastic materials	B65D 75/40 - B65D 75/50

Special rules of classification

The use of available Indexing Codes is mandatory.

B65D 75/5894

{Preformed openings provided in a wall portion and covered by a separate removable flexible element}

Definition statement

This place covers:

Illustrative example of subject matter classified in this group:

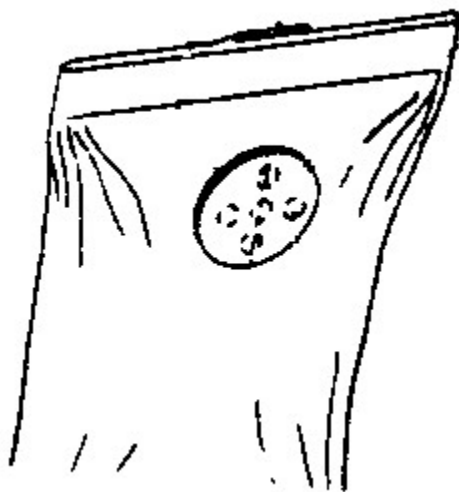

References

Informative references

Attention is drawn to the following places, which may be of interest for search:

Non-integral frangible members applied to, or inserted in, a preformed opening	B65D 17/50
Packages formed by enclosing successive articles, or increments of material, in webs, e.g. folded or tubular webs, or by subdividing tubes filled with liquid, semi-liquid, or plastic materials	B65D 75/40 - B65D 75/50

Special rules of classification

The use of available Indexing Codes is mandatory.

B65D 75/66**Inserted or applied tearing-strings or like flexible elements****Definition statement**

This place covers:

Illustrative example of subject matter classified in this group:

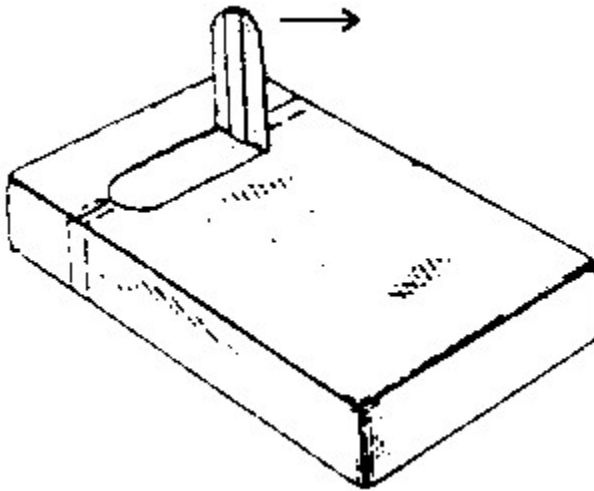
**References****Informative references**

Attention is drawn to the following places, which may be of interest for search:

Tearing-strings or -strips	B65D 27/38
Tearing-strings or like flexible elements	B65D 77/32

Special rules of classification

The use of available Indexing Codes is mandatory.

B65D 75/68

extending through wrapper closure or between wrapper layers

Definition statement

This place covers:

Illustrative example of subject matter classified in this group:

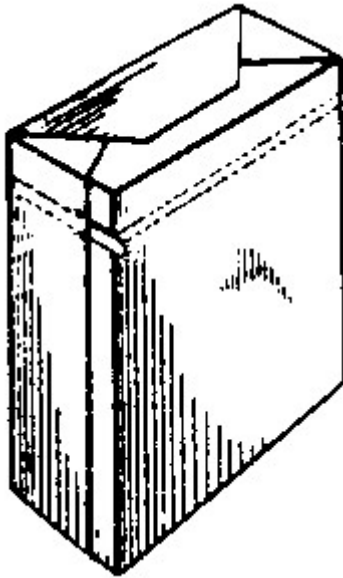

References

Informative references

Attention is drawn to the following places, which may be of interest for search:

Opening devices	B65D 85/1027
-----------------	------------------------------

Special rules of classification

The use of available Indexing Codes is mandatory.

B65D 75/70

Rigid cutting or tearing devices

Definition statement

This place covers:

Illustrative example of subject matter classified in this group:

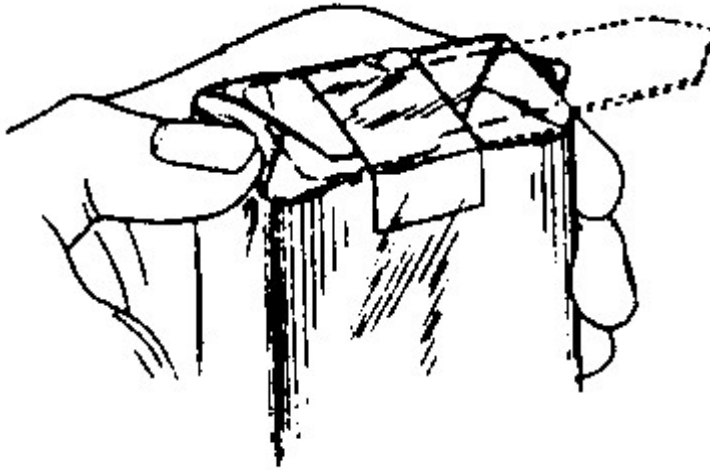

References

Informative references

Attention is drawn to the following places, which may be of interest for search:

Rigid cutting or tearing devices	B65D 77/40
Opening devices	B65D 85/1027

Special rules of classification

The use of available Indexing Codes is mandatory.

B65D 77/003**{Articles enclosed in rigid or semi-rigid containers, the whole being wrapped}****Definition statement***This place covers:*

Illustrative example of subject matter classified in this group:

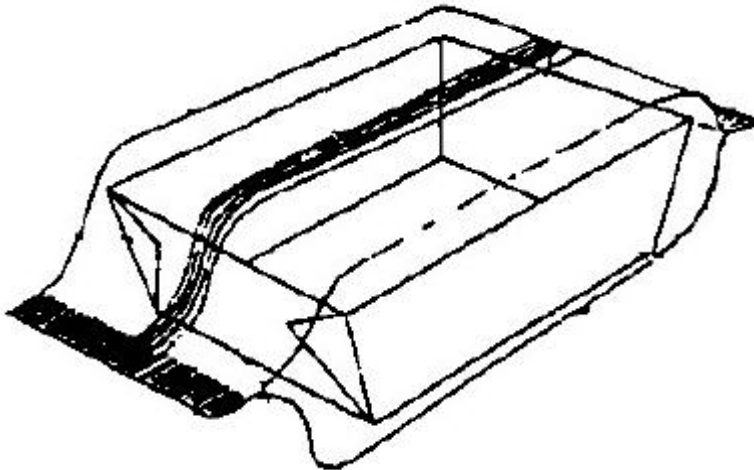
**References****Limiting references***This place does not cover:*

Tray-like elements provided with handles without partitions	B65D 71/0007
Wrapped articles in rigid or semi-rigid containers	B65D 77/02
Rigid or semi-rigid containers in flexible containers	B65D 77/0406
Flexible containers in rigid or semi-rigid containers	B65D 77/06

Informative references*Attention is drawn to the following places, which may be of interest for search:*

External coverings or coatings	B65D 5/62
Rigid or semi-rigid containers in flexible containers	B65D 77/0406

B65D 77/006

{Containers simulating a book (pencil cases [A45C 11/34](#); books, book covers [B42D](#); albums, filing appliances, e.g. boxes, [B42F](#); for videos [G11B](#))}

Definition statement

This place covers:

Illustrative example of subject matter classified in this group:

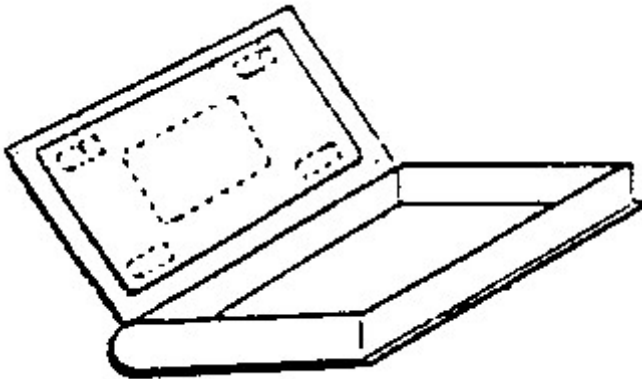
**B65D 77/02**

Wrapped articles enclosed in rigid or semi-rigid containers

Definition statement

This place covers:

Illustrative example of subject matter classified in this group:

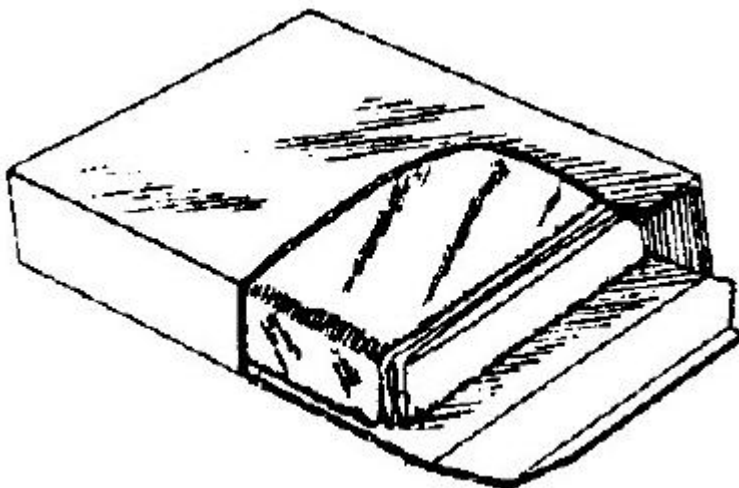
**References****Limiting references**

This place does not cover:

Rigid or semi-rigid containers in wrapper	B65D 77/003
---	-----------------------------

Rigid or semi-rigid containers in flexible containers	B65D 77/0406
Flexible containers in rigid or semi-rigid containers	B65D 77/06

B65D 77/04

Articles or materials enclosed in two or more containers disposed one within another

Definition statement

This place covers:

Illustrative example of subject matter classified in this group:

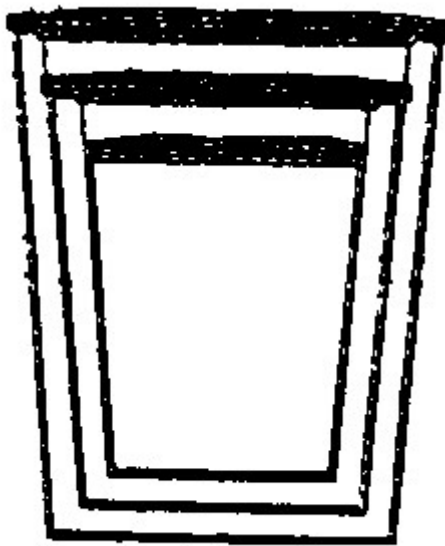

References

Limiting references

This place does not cover:

Bottle-crates containing wrapped bottles	B65D 1/243
For bottles with handles in a sleeve	B65D 23/001 , B65D 23/08 , B65D 23/10
Coverings for bottles	B65D 23/08
Wrapped articles in wrapper	B65D 75/38
Rigid or semi-rigid containers in wrapper	B65D 77/003
Wrapped articles in rigid or semi-rigid containers	B65D 77/02
Rigid or semi-rigid containers in flexible containers	B65D 77/0406
Flexible containers in rigid or semi-rigid containers	B65D 77/06
Packages containing several articles intended to be suspended from a display rod	B65D 83/0088

Special rules of classification

The use of available Indexing Codes is mandatory.

B65D 77/0406

{Rigid containers in preformed flexible containers}

Definition statement

This place covers:

Illustrative example of subject matter classified in this group:

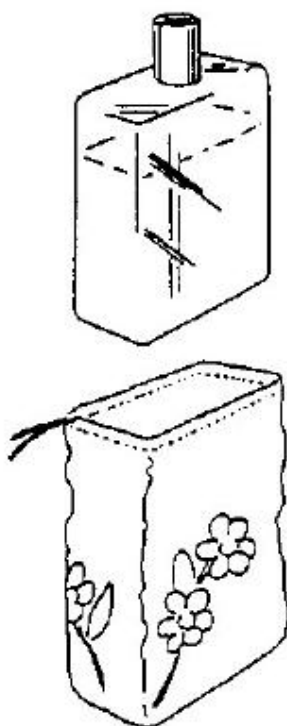
**References****Limiting references**

This place does not cover:

Coverings for bottles	B65D 23/08
Rigid or semi-rigid containers in wrappers	B65D 77/003
Wrapped articles in rigid or semi-rigid containers	B65D 77/02
Flexible containers in rigid or semi-rigid containers	B65D 77/06

Special rules of classification

The use of available Indexing Codes is mandatory.

B65D 77/0413

{the inner and outer containers being rigid or semi-rigid and the outer container being of polygonal cross-section formed by folding or erecting one or more blanks, e.g. carton}

Definition statement

This place covers:

Illustrative example of subject matter classified in this group:

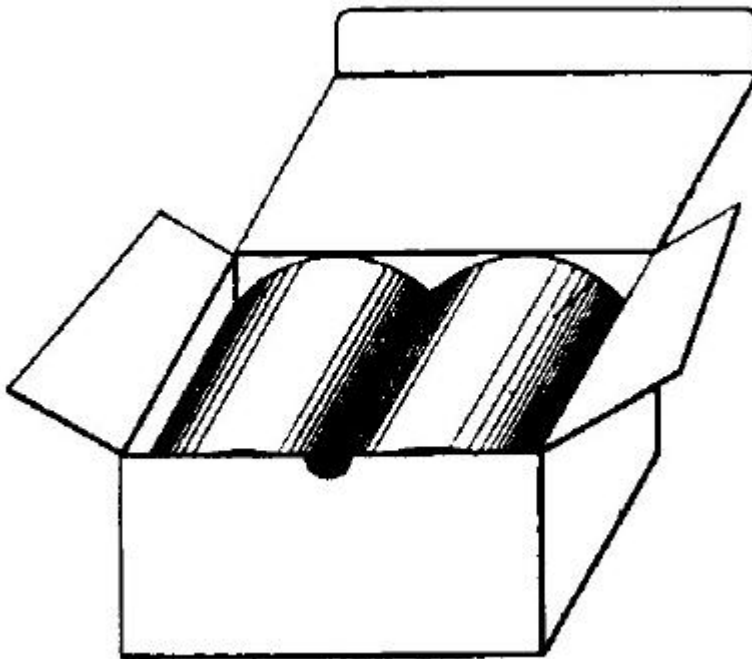
**References****Limiting references**

This place does not cover:

Rigid or semi-rigid containers in wrapper	B65D 77/003
Wrapped articles in rigid or semi-rigid containers	B65D 77/02
Rigid or semi-rigid containers in flexible containers	B65D 77/0406
Flexible containers in rigid or semi-rigid containers	B65D 77/06

Special rules of classification

The use of available Indexing Codes is mandatory.

B65D 77/042

{the inner container being of polygonal cross-section formed by folding or erecting one or more blanks, e.g. carton}

Definition statement

This place covers:

Illustrative example of subject matter classified in this group:

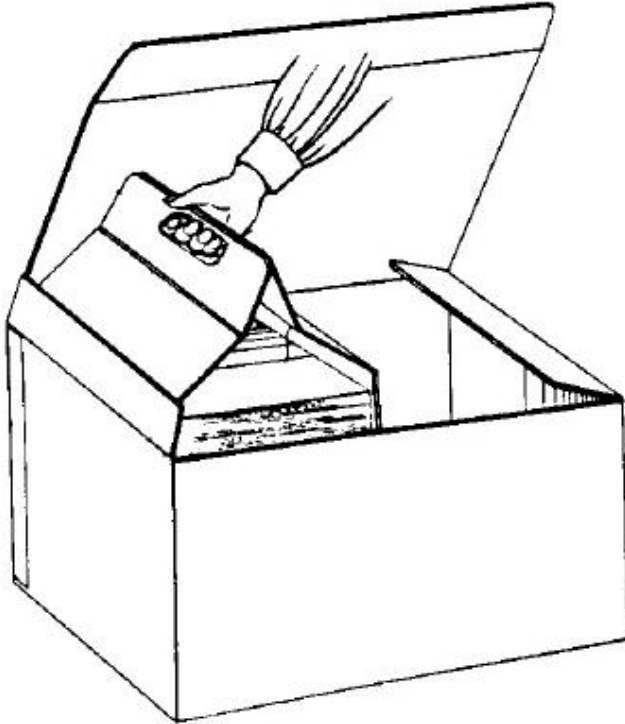

Special rules of classification

The use of available Indexing Codes is mandatory.

B65D 77/0426

{the inner container being a bottle, canister or like hollow container}

Definition statement

This place covers:

Illustrative example of subject matter classified in this group:

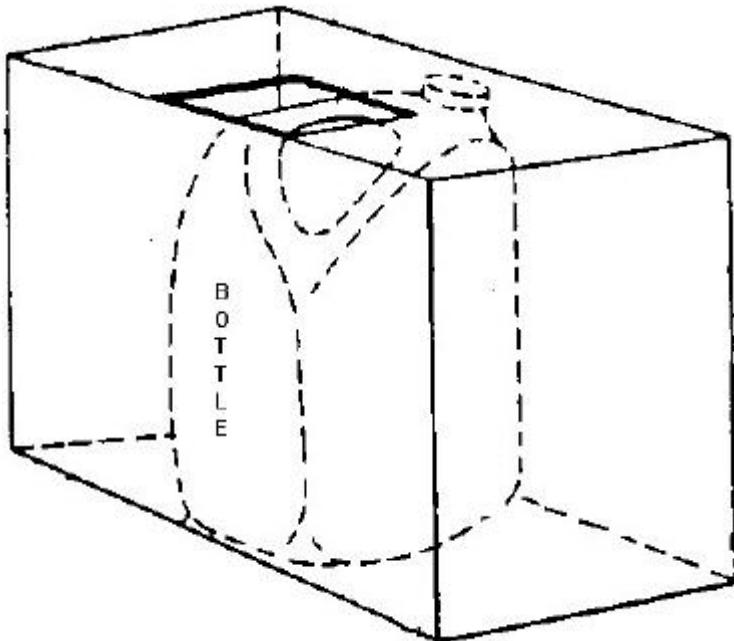

Special rules of classification

The use of available Indexing Codes is mandatory.

B65D 77/0433

{the inner container being a tray or like shallow container, not formed by folding or erecting one or more blanks ([B65D 81/3862](#) takes precedence)}

Definition statement

This place covers:

Illustrative example of subject matter classified in this group:

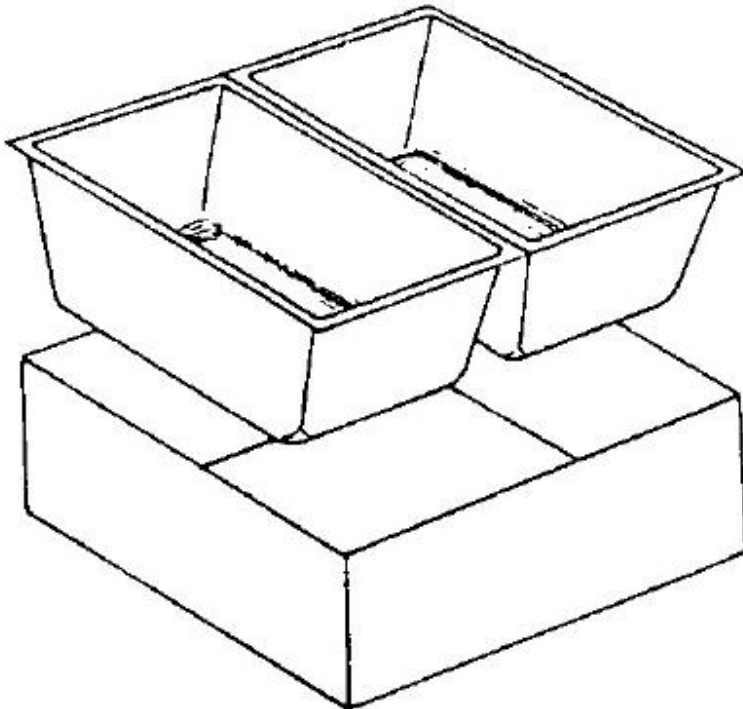

References

Informative references

Attention is drawn to the following places, which may be of interest for search:

Tray-like elements formed in one piece	B65D 5/503
--	----------------------------

Special rules of classification

The use of available Indexing Codes is mandatory.

B65D 77/044

{the inner container being a filled deformable tube}

Definition statement

This place covers:

Illustrative example of subject matter classified in this group:

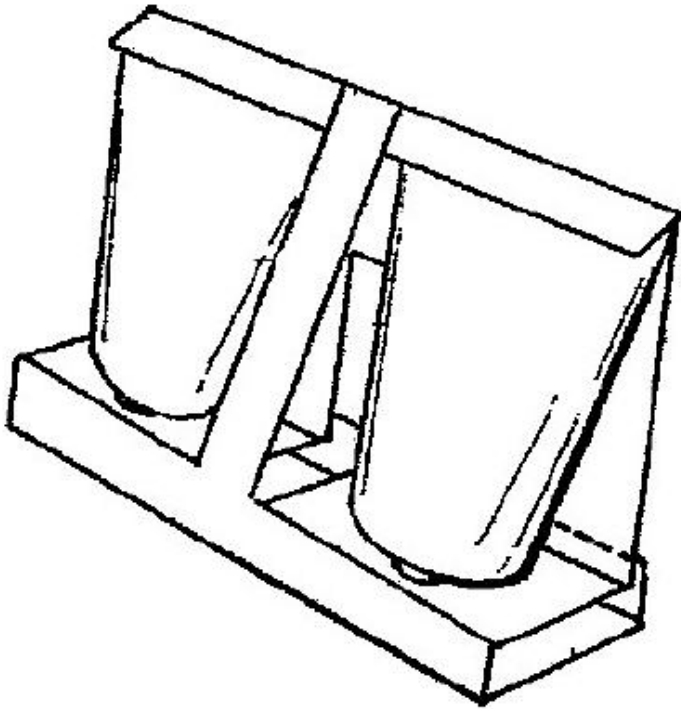

Special rules of classification

The use of available Indexing Codes is mandatory.

B65D 77/0446

{the inner and outer containers being rigid or semi-rigid and the outer container being of polygonal cross-section not formed by folding or erecting one or more blanks ([B65D 81/3825](#) takes precedence)}

Definition statement

This place covers:

Illustrative example of subject matter classified in this group:

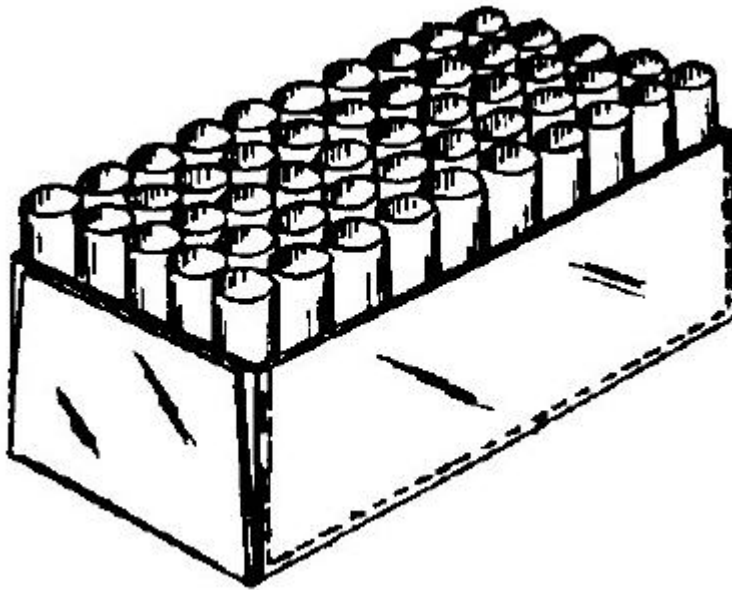
**References****Limiting references**

This place does not cover:

Rigid or semi-rigid containers in wrapper	B65D 77/003
Wrapped articles in rigid or semi-rigid containers	B65D 77/02
Rigid or semi-rigid containers in flexible containers	B65D 77/0406
Flexible containers in rigid or semi-rigid containers	B65D 77/06

Special rules of classification

The use of available Indexing Codes is mandatory.

B65D 77/0453

{the inner container having a polygonal cross-section}

Definition statement

This place covers:

Illustrative example of subject matter classified in this group:

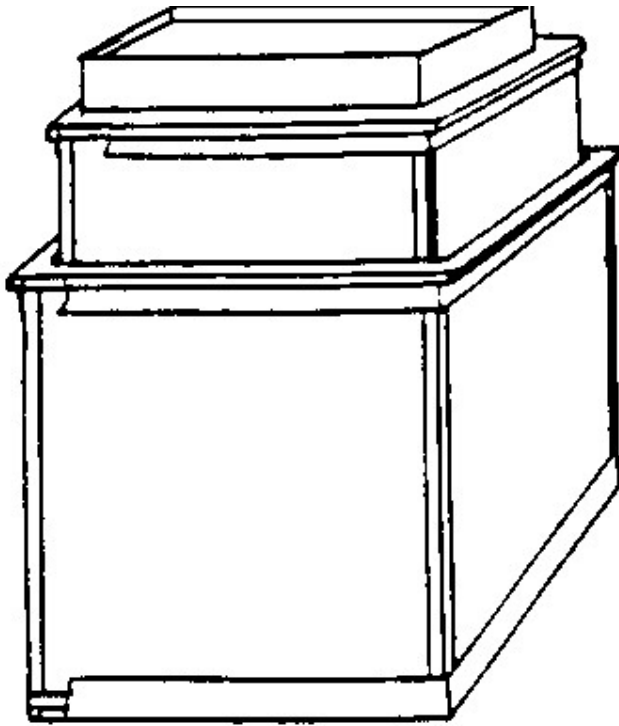

Special rules of classification

The use of available Indexing Codes is mandatory.

B65D 77/046

{and being a tray or like shallow container}

Definition statement

This place covers:

Illustrative example of subject matter classified in this group:

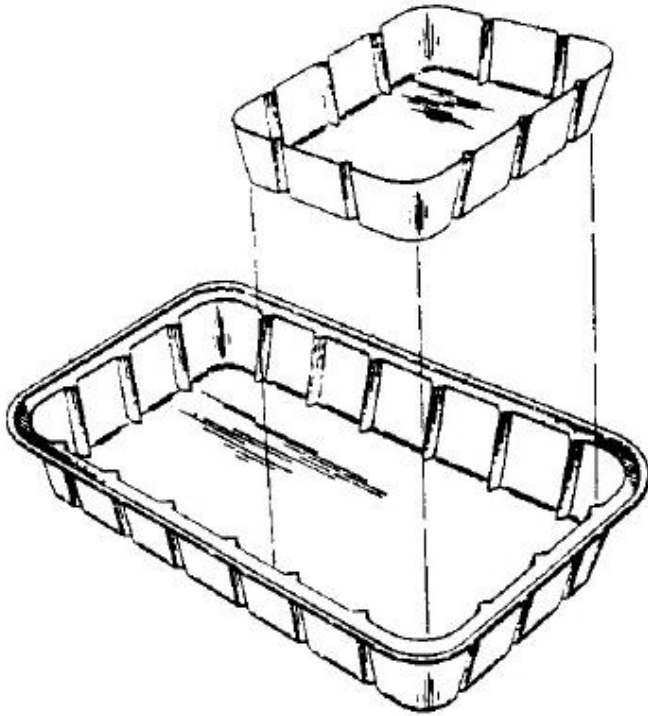

Special rules of classification

The use of available Indexing Codes is mandatory.

B65D 77/0466**{the containers being mounted on a pallet}****Definition statement***This place covers:*

Illustrative example of subject matter classified in this group:

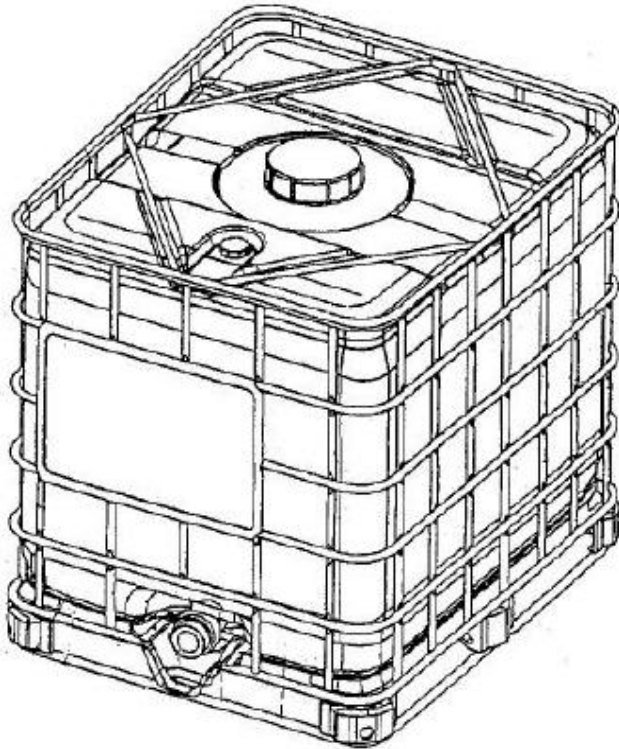
**References****Limiting references***This place does not cover:*

Without a pallet	B65D 77/0453
Flexible container within a box pallet	B65D 77/061
Means for preventing electrostatic charges	B65D 2213/02

Special rules of classification

The use of available Indexing Codes is mandatory.

B65D 77/0473

{the inner container being a filled deformable tube}

Definition statement

This place covers:

Illustrative example of subject matter classified in this group:

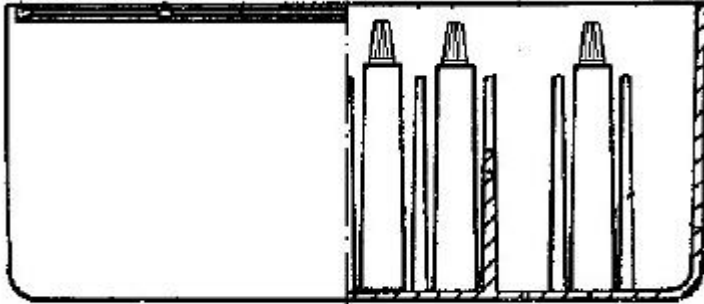
**Special rules of classification**

The use of available Indexing Codes is mandatory.

B65D 77/048

{the inner and outer containers being rigid and the outer container being of curved cross-section, e.g. cylindrical ([B65D 81/3825](#) takes precedence)}

Definition statement

This place covers:

Illustrative example of subject matter classified in this group:

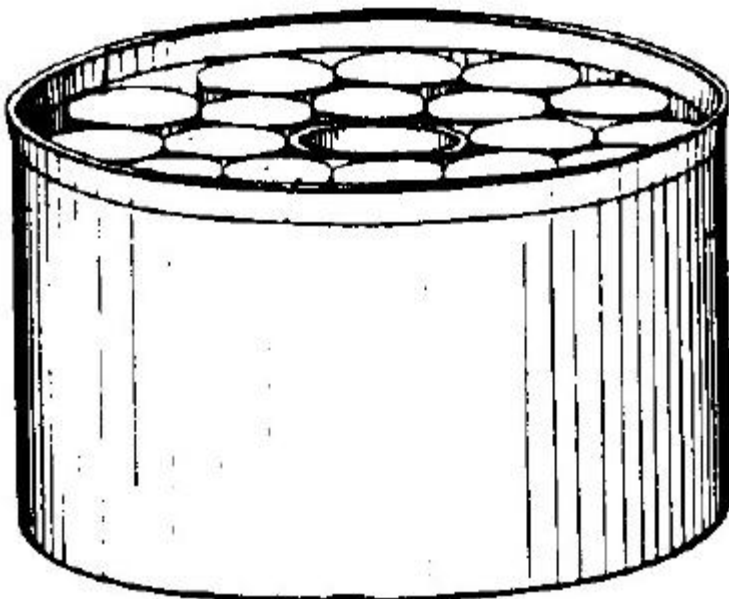

References

Limiting references

This place does not cover:

Rigid or semi-rigid containers in wrapper	B65D 77/003
Wrapped articles in rigid or semi-rigid containers	B65D 77/02
Rigid or semi-rigid containers in flexible containers	B65D 77/0406
Flexible containers in rigid or semi-rigid containers	B65D 77/06

Special rules of classification

The use of available Indexing Codes is mandatory.

B65D 77/0486

{the inner container being coaxially disposed within the outer container
([B65D 81/3876](#) takes precedence)}

Definition statement

This place covers:

Illustrative example of subject matter classified in this group:

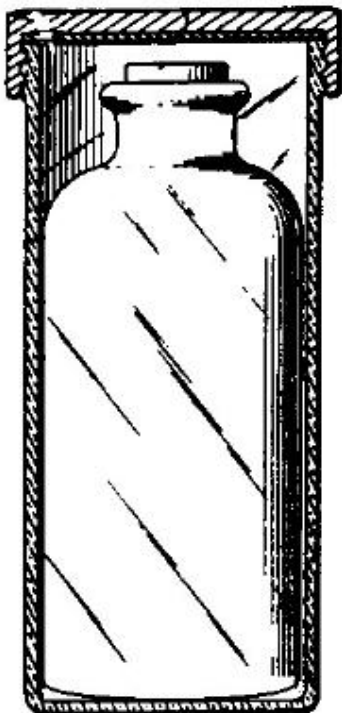

Special rules of classification

The use of available Indexing Codes is mandatory.

B65D 77/0493

{and retained at a distance of the inner side-wall of the outer container, e.g. within a bottle neck}

Definition statement

This place covers:

Illustrative example of subject matter classified in this group:

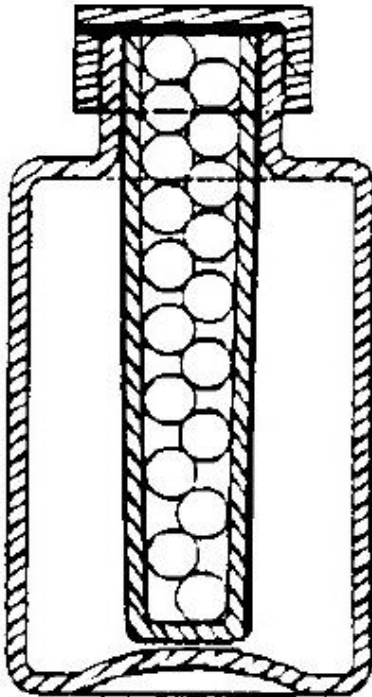
**References****Limiting references**

This place does not cover:

Closures with auxiliary containers for additional articles or material	B65D 51/28
--	----------------------------

Special rules of classification

The use of available Indexing Codes is mandatory.

B65D 77/06

Liquids or semi-liquids {or other materials or articles} enclosed in flexible containers disposed within rigid containers

References**Limiting references**

This place does not cover:

Rigid or semi-rigid containers in wrapper	B65D 77/003
---	-----------------------------

Wrapped articles in rigid or semi-rigid containers	B65D 77/02
Rigid or semi-rigid containers in flexible containers	B65D 77/0406

B65D 77/061

{the containers being mounted on a pallet}

Definition statement

This place covers:

Illustrative example of subject matter classified in this group:

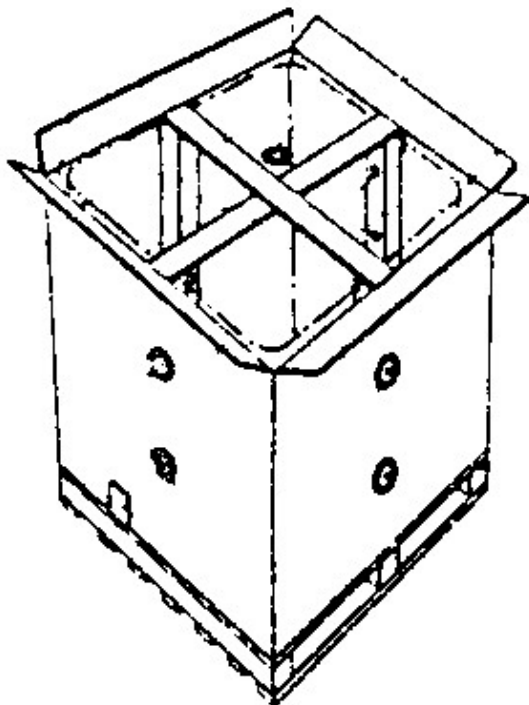

References

Informative references

Attention is drawn to the following places, which may be of interest for search:

External frames or supports adapted to be assembled around, or applied to, articles	B65D 61/00
Large flexible containers	B65D 88/16
Large flexible bellows-shaped containers	B65D 88/18
Large flexible containers with rigid end-walls	B65D 88/20

B65D 77/064

{comprising discharging means formed by cutting a part, e.g. a corner, of the flexible container}

Definition statement

This place covers:

Illustrative example of subject matter classified in this group:

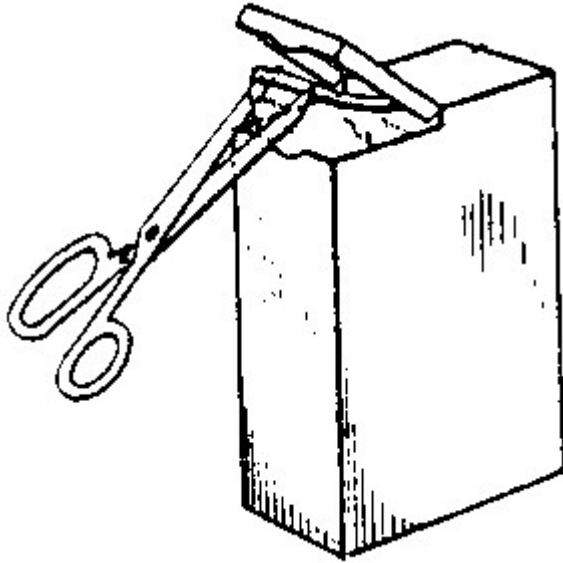

B65D 77/065

{Spouts, pouring necks or discharging tubes fixed to or integral with the flexible container}

Definition statement

This place covers:

Illustrative example of subject matter classified in this group:

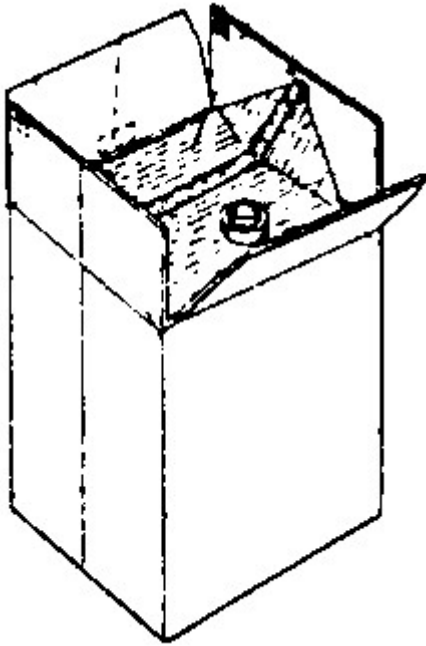

References

Informative references

Attention is drawn to the following places, which may be of interest for search:

Spouts	B65D 75/5861
Integral spouts	B65D 75/5866

B65D 77/067

{combined with a valve, a tap or a piercer}

Definition statement

This place covers:

Illustrative example of subject matter classified in this group:

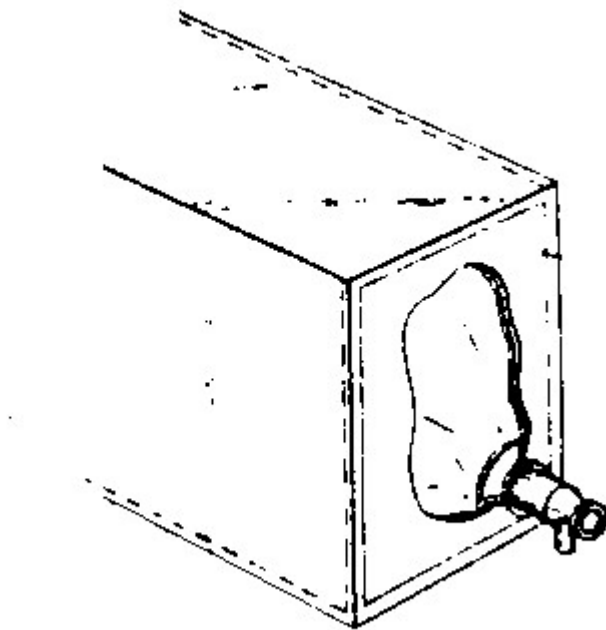

B65D 77/068**{Spouts formed separately from the container}****Definition statement***This place covers:*

Illustrative example of subject matter classified in this group:

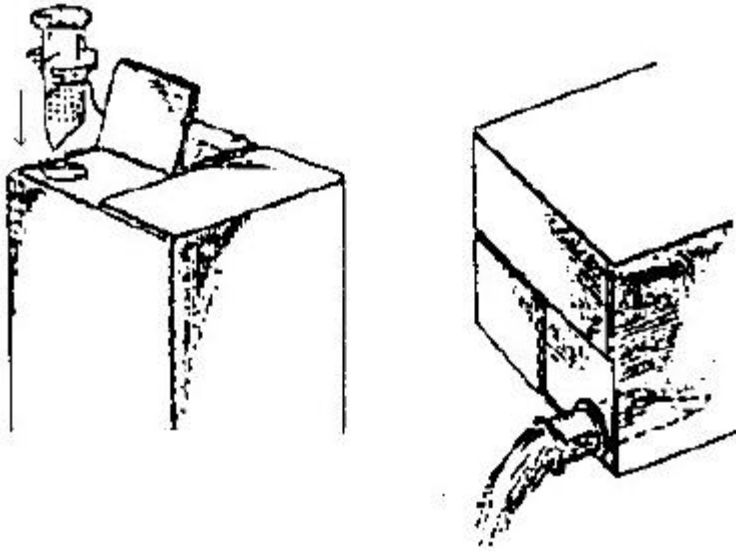
**References****Informative references***Attention is drawn to the following places, which may be of interest for search:*

Separable nozzles or spouts	B65D 25/48
-----------------------------	----------------------------

B65D 77/08

Materials, e.g. different materials, enclosed in separate compartments formed during filling of a single container

Definition statement

This place covers:

Illustrative example of subject matter classified in this group:

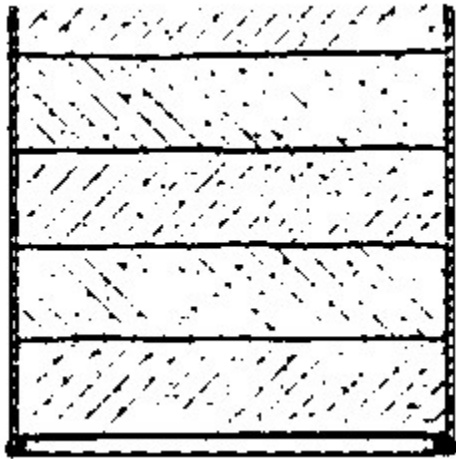

B65D 77/12

by collapsing and flattening the mouth portion of the container and securing without folding, e.g. by pressure-sensitive adhesive, heat-sealing, welding or applying separate securing members

Definition statement

This place covers:

Illustrative example of subject matter classified in this group:

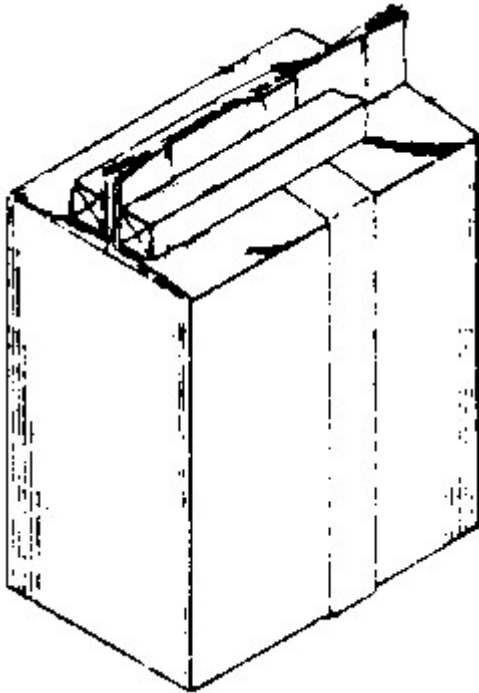

B65D 77/14

by flattening and subsequently folding or rolling the mouth portion

Definition statement

This place covers:

Illustrative example of subject matter classified in this group:

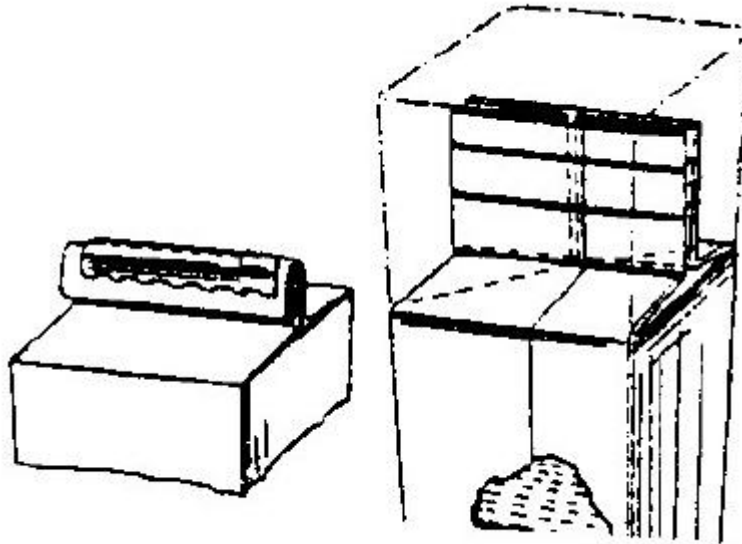

B65D 77/16

by collapsing and twisting mouth portion

Definition statement

This place covers:

Illustrative example of subject matter classified in this group:

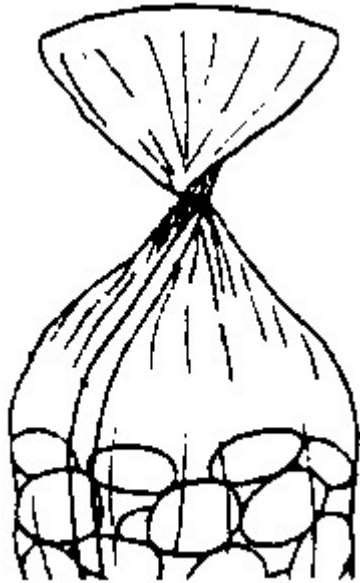

B65D 77/18

and securing by a deformable clip or binder

Definition statement

This place covers:

Illustrative example of subject matter classified in this group:

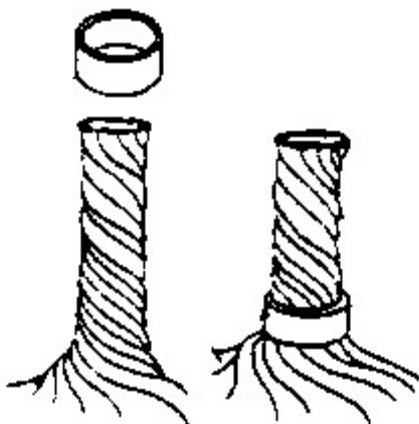

References

Limiting references

This place does not cover:

For sacks	B65D 33/16
Releasable fastenings clips	F16B 2/20

B65D 77/185

{with means for discouraging or for indicating unauthorised opening or removal}

Definition statement

This place covers:

Illustrative example of subject matter classified in this group:

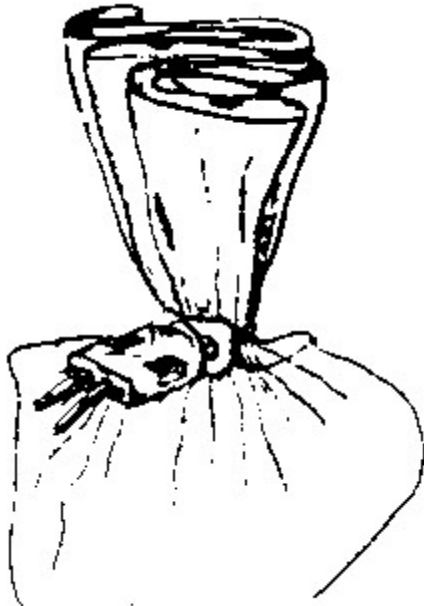

References

Limiting references

This place does not cover:

Postal sacks	B65D 29/00
--------------	----------------------------

Informative references

Attention is drawn to the following places, which may be of interest for search:

Details of, or accessories for, sacks or bags with special means for indicating unauthorised opening	B65D 33/34
--	----------------------------

B65D 77/20

by applying separate lids or covers {, i.e. flexible membrane or foil-like covers}

References**Limiting references**

This place does not cover:

Cover elements inserted in crates	B65D 1/246
Meshed or apertured flexible closures to allow contents to breathe	B65D 85/345
Lids or covers welded or adhered to the container	B65D 2543/00425

Informative references

Attention is drawn to the following places, which may be of interest for search:

Magnetic connections	B65D 2313/04
----------------------	------------------------------

Special rules of classification

The use of available Indexing Codes is mandatory.

B65D 77/2004

{the cover being maintained on the container by mechanical means, e.g. crimping, clamping, riveting ([B65D 77/2024](#) takes precedence)}

Definition statement

This place covers:

Illustrative example of subject matter classified in this group:

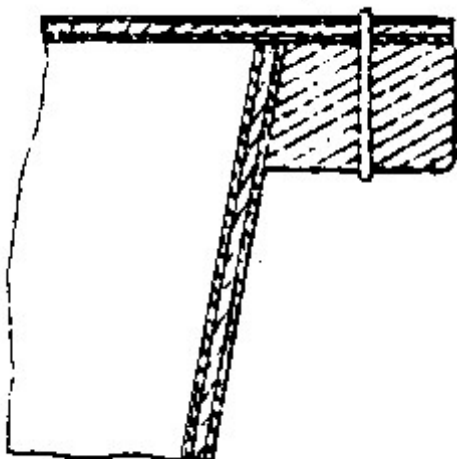

References

Limiting references

This place does not cover:

Container closures formed after filling by applying separate lids or covers the cover being welded or adhered to the container	B65D 77/2024
--	------------------------------

Informative references

Attention is drawn to the following places, which may be of interest for search:

Containers formed by rolling, or by rolling and pressing	B65D 7/36
Closures secured by folding or rolling and pressing	B65D 17/08

Special rules of classification

The use of available Indexing Codes is mandatory.

B65D 77/2008

{the container flange being crimped over the cover}

Definition statement

This place covers:

Illustrative example of subject matter classified in this group:

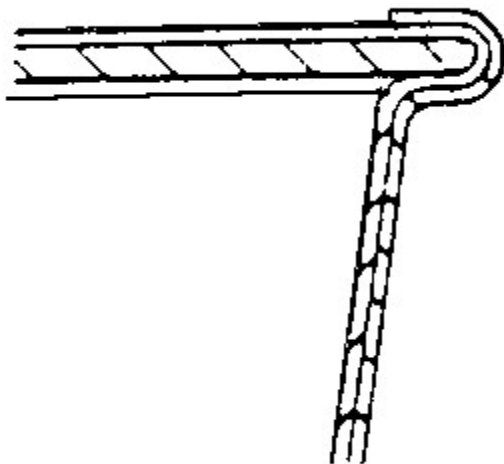

Special rules of classification

The use of available Indexing Codes is mandatory.

B65D 77/2012

{the cover being crimped or folded over the container flange}

Definition statement

This place covers:

Illustrative example of subject matter classified in this group:

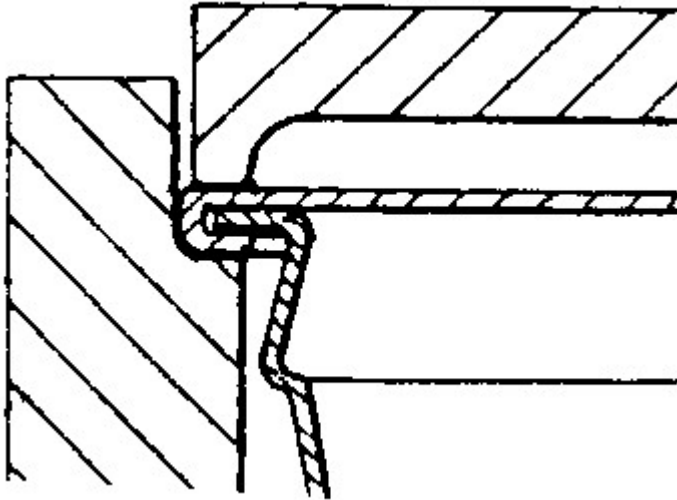

Special rules of classification

The use of available Indexing Codes is mandatory.

B65D 77/2016

{the cover being maintained by projections or recesses on the container}

Definition statement

This place covers:

Illustrative example of subject matter classified in this group:

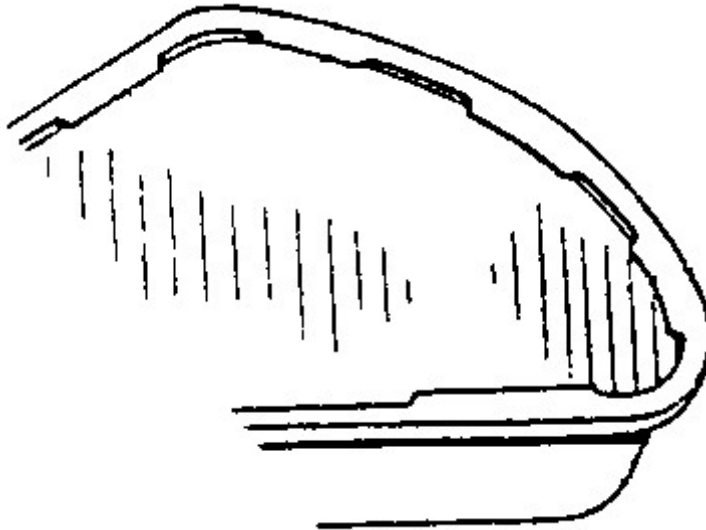
**References****Informative references**

Attention is drawn to the following places, which may be of interest for search:

Disc closures	B65D 39/02
Removable lids or covers secured by snapping over beads or projections, only on the inside, or a part turned to the inside, of the mouth	B65D 43/021

Special rules of classification

The use of available Indexing Codes is mandatory.

B65D 77/202

{the cover being connected to the container by separate circumferential ring elements}

Definition statement

This place covers:

Illustrative example of subject matter classified in this group:

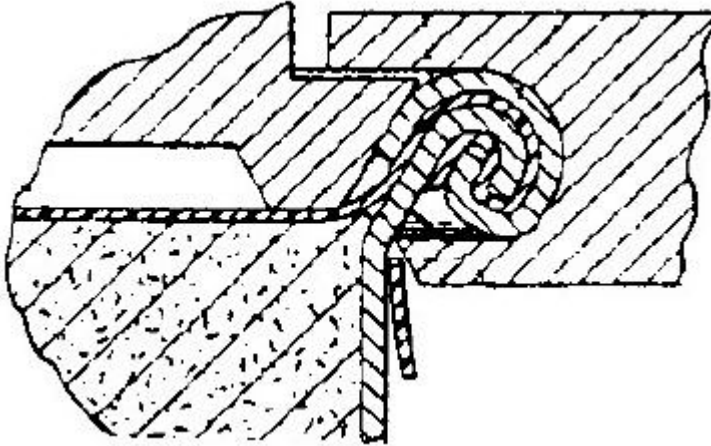
**Special rules of classification**

The use of available Indexing Codes is mandatory.

B65D 77/204

{the cover having an unsealed portion for initiating removal ([B65D 77/2036](#) takes precedence)}

References**Limiting references**

This place does not cover:

Means for opening the cover other than, or in addition to, a pull tab, the seal having a stress concentrating portion	B65D 77/2036
---	------------------------------

B65D 77/2044

{whereby a layer of the container or cover fails, e.g. cohesive failure ([B65D 77/2036](#) takes precedence)}

References**Limiting references**

This place does not cover:

Means for opening the cover other than, or in addition to, a pull tab, the seal having a stress concentrating portion	B65D 77/2036
---	------------------------------

B65D 77/2048

{whereby part of the container or cover has been weakened, e.g. perforated or precut ([B65D 77/2036](#) takes precedence)}

References**Limiting references**

This place does not cover:

Means for opening the cover other than, or in addition to, a pull tab, the seal having a stress concentrating portion	B65D 77/2036
---	------------------------------

B65D 77/225

{Pressure relief-valves incorporated in a container wall, e.g. valves comprising at least one elastic element}

Definition statement

This place covers:

Illustrative example of subject matter classified in this group:

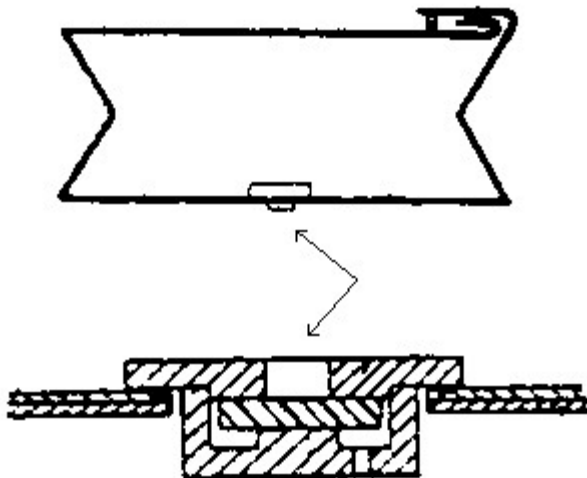
**References****Limiting references**

This place does not cover:

Filling valves	B65D 31/14
Included in a closure	B65D 51/16

Informative references

Attention is drawn to the following places, which may be of interest for search:

Ventilation or drainage of bags	B65D 33/01
Venting air or gas with the element being a valve	B65D 51/1644

Venting means	B65D 2205/00
---------------	------------------------------

B65D 77/24

**Inserts or accessories added or incorporated during filling of containers
(opening devices [B65D 77/30](#))**

References

Limiting references

This place does not cover:

- cards or coupons

Information or decoration elements	B65D 5/4212 , B65D 33/004
Means for the attachment of tags	B65D 23/14
Means for the attachment of labels, cards, coupons or the like	B65D 25/205
Closures provided with decoration, information or contents indicating devices, labels	B65D 51/245
Cards, coupons, or other inserts or accessories	B65D 75/54

Informative references

Attention is drawn to the following places, which may be of interest for search:

Inserts or accessories added or joined to the container	B65D 85/1081
---	------------------------------

B65D 77/245

{Utensils for removing the contents from the package, e.g. spoons, forks, spatulas ([B65D 77/28](#) takes precedence)}

Definition statement

This place covers:

Illustrative example of subject matter classified in this group:

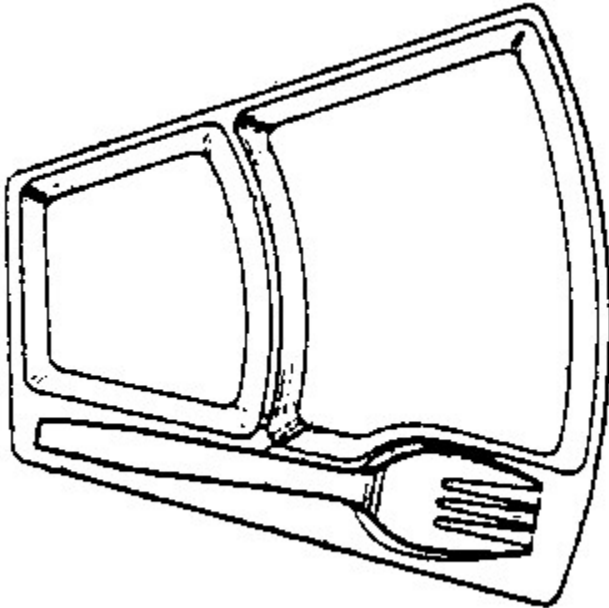
**References****Limiting references**

This place does not cover:

Lids with eating utensils or spatulas	B65D 51/246
Cards, coupons, or drinking straws	B65D 77/28
Utensils per se	A47G 21/00
Spoon-shaped dispensing spouts for administering medicine	A61J 7/0015
Measuring spoons per se	A61J 7/0015 , G01F 19/002

Informative references

Attention is drawn to the following places, which may be of interest for search:

Utensils attached to trays, cups, etc.	A47G 19/06
--	----------------------------

B65D 77/26**Elements or devices for locating or protecting articles****Definition statement**

This place covers:

Illustrative example of subject matter classified in this group:

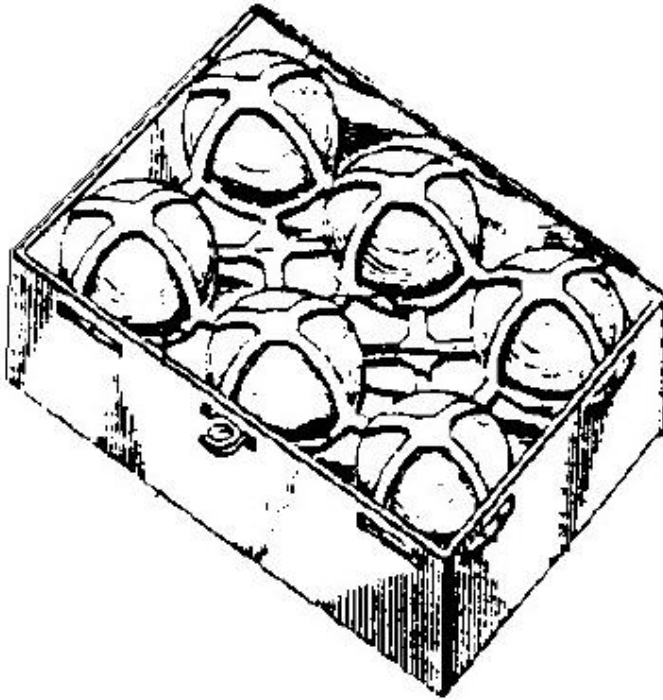
**References****Limiting references**

This place does not cover:

Internal heat-shrinkable sheets for maintaining the contents	B65D 5/5028
--	-----------------------------

Informative references

Attention is drawn to the following places, which may be of interest for search:

Internal heat-shrinkable sheets for maintaining the contents	B65D 5/5028
Devices to locate articles in containers	B65D 25/10

B65D 77/28

Cards, coupons, or drinking straws {([B65D 5/4212](#), [B65D 23/14](#), [B65D 25/205](#), [B65D 33/004](#), [B65D 51/245](#), [B65D 75/54](#) take precedence)}

Definition statement

This place covers:

Illustrative example of subject matter classified in this group:

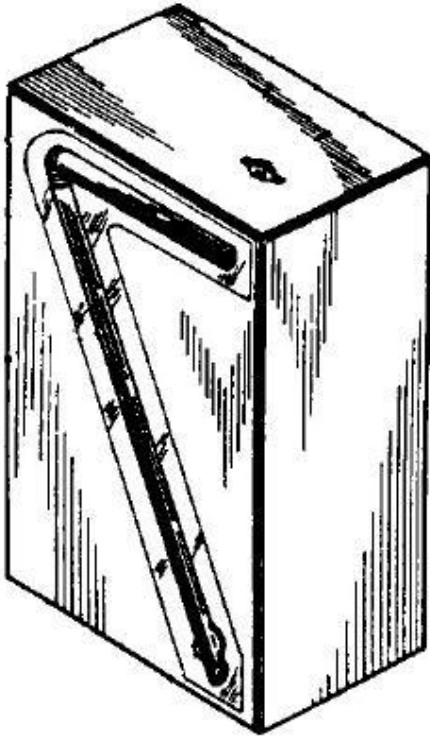

References

Limiting references

This place does not cover:

Details of containers or of foldable or erectable container blanks, information or decoration elements	B65D 5/4212
Means for the attachment of tags	B65D 23/14
Means for the attachment of labels, cards, coupons or the like	B65D 25/205
Details of, or accessories for, sacks or bags, information or decoration elements	B65D 33/004
Covers for drinking cups having means, e.g. weakened zones, for inserting a drinking straw (without means for the attachment of the drinking straw to the container):	B65D 47/36 , B65D 2231/02
Closures provided with decoration, information or contents indicating devices, labels	B65D 51/245
Cards, coupons, or other inserts or accessories	B65D 75/54
Attached or integral utensils for removing the contents, e.g. forks, spoons, spatulas	B65D 77/245

Containers with means for inserting a drinking straw (without means for the attachment of the drinking straw to the container): relevant group for the container construction +	B65D 2231/02
Beverage cans incorporating a drinking straw	B65D 2517/0049
Construction of the drinking straws per se	A47G 21/18

B65D 77/283

{located initially inside the container, whereby the straw is revealed only upon opening the container, e.g. pop-up straws}

Definition statement

This place covers:

Illustrative example of subject matter classified in this group:

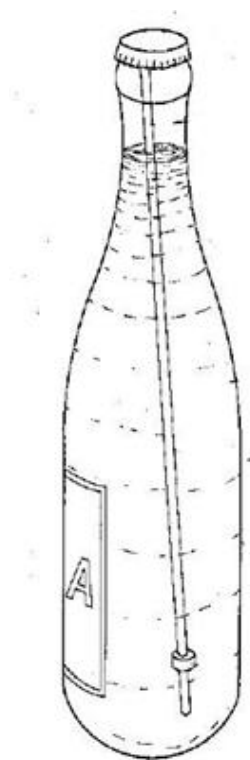

B65D 77/286

{formed integrally with the container (containers having integrally formed tubes with contents expelled by deforming the container [B65D 1/326](#))}

Definition statement

This place covers:

Illustrative example of subject matter classified in this group:

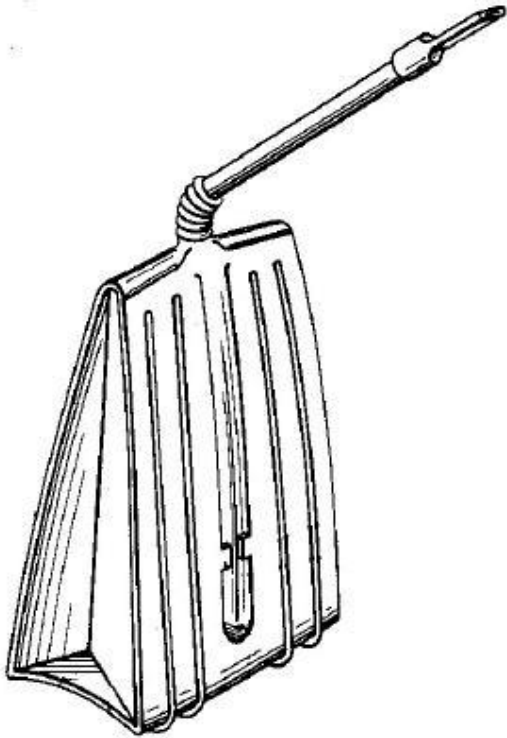
**References****Limiting references**

This place does not cover:

Containers having integrally formed tubes with contents expelled by deforming the container	B65D 1/326
---	----------------------------

Informative references

Attention is drawn to the following places, which may be of interest for search:

Integral or attached nozzles or spouts	B65D 25/42
Closures with filling and discharging, or with discharging, devices the spout being either flexible or having a flexible wall portion, whereby the spout is foldable between a dispensing and a non-dispensing position	B65D 47/066
Integral spouts	B65D 75/5866

B65D 77/30

Opening or contents-removing devices added or incorporated during filling or closing of containers {([B65D 77/20](#) takes precedence)}

References**Limiting references**

This place does not cover:

Container closures formed after filling by applying separate lids or covers	B65D 77/20
---	----------------------------

B65D 77/32

Tearing-strings or like flexible elements

Definition statement

This place covers:

Illustrative example of subject matter classified in this group:

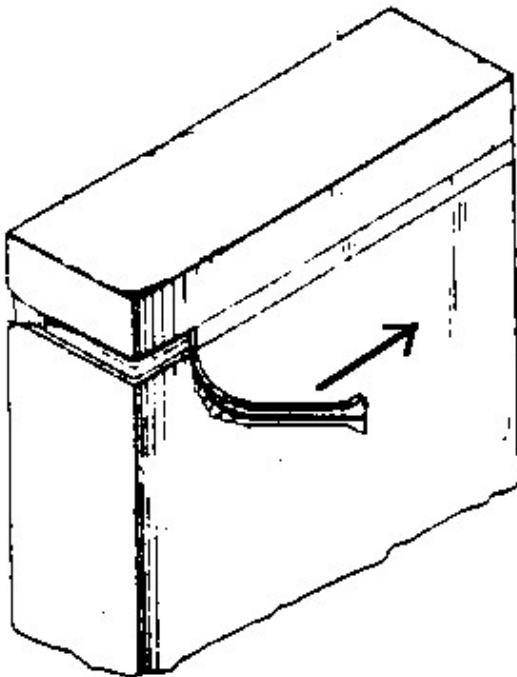
**References****Informative references**

Attention is drawn to the following places, which may be of interest for search:

Tearing-strings or -strips	B65D 27/38
Inserted or applied tearing-strings or like flexible elements	B65D 75/66
Opening devices	B65D 85/1027

B65D 77/34

enclosed in a mouth seal

Definition statement

This place covers:

Illustrative example of subject matter classified in this group:

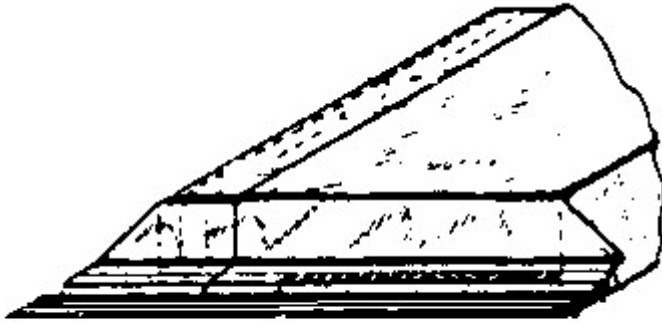
**B65D 77/36**

disposed beneath a wrapper, label, or other element of sheet material securing a lid, cover, or container mouth

Definition statement

This place covers:

Illustrative example of subject matter classified in this group:

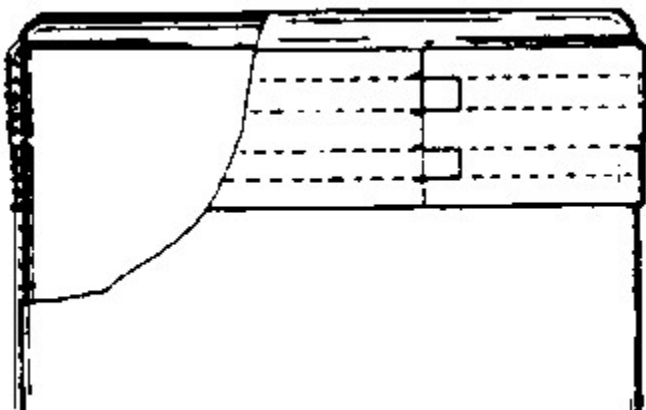
**References****Informative references**

Attention is drawn to the following places, which may be of interest for search:

Destructible or permanently removable bands	B65D 55/0818
---	------------------------------

B65D 77/38

Weakened closure seams

Definition statement

This place covers:

Illustrative example of subject matter classified in this group:

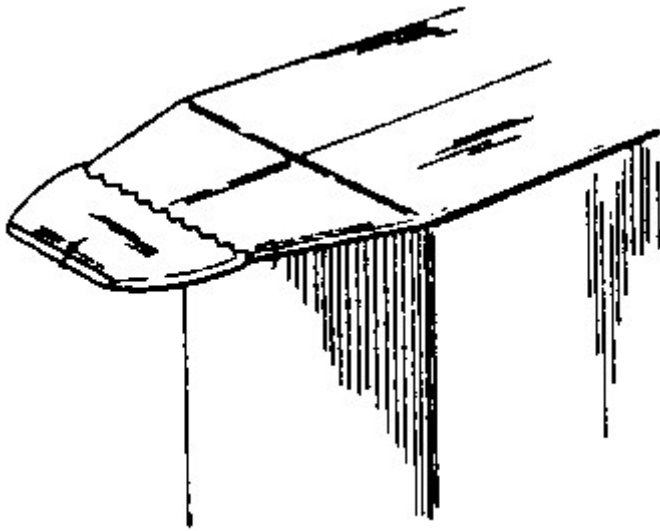

B65D 77/40

Rigid cutting or tearing devices

Definition statement

This place covers:

Illustrative example of subject matter classified in this group:



References

Informative references

Attention is drawn to the following places, which may be of interest for search:

Rigid cutting or tearing devices	B65D 75/70
----------------------------------	----------------------------

B65D 79/005

{Packages having deformable parts for indicating or neutralizing internal pressure-variations by other means than venting}

Definition statement

This place covers:

Flexible packages having deformable parts for indicating or neutralizing internal pressure variations by other means than venting.

Special rules of classification

Means for rigid or semi-rigid containers are classified in [B65D 79/008](#).

Means for closures, e.g. caps or lids are classified in [B65D 79/0087](#).

B65D 79/0081

{in the bottom part thereof}

Definition statement

This place covers:

Illustrative example of subject matter classified in this group.

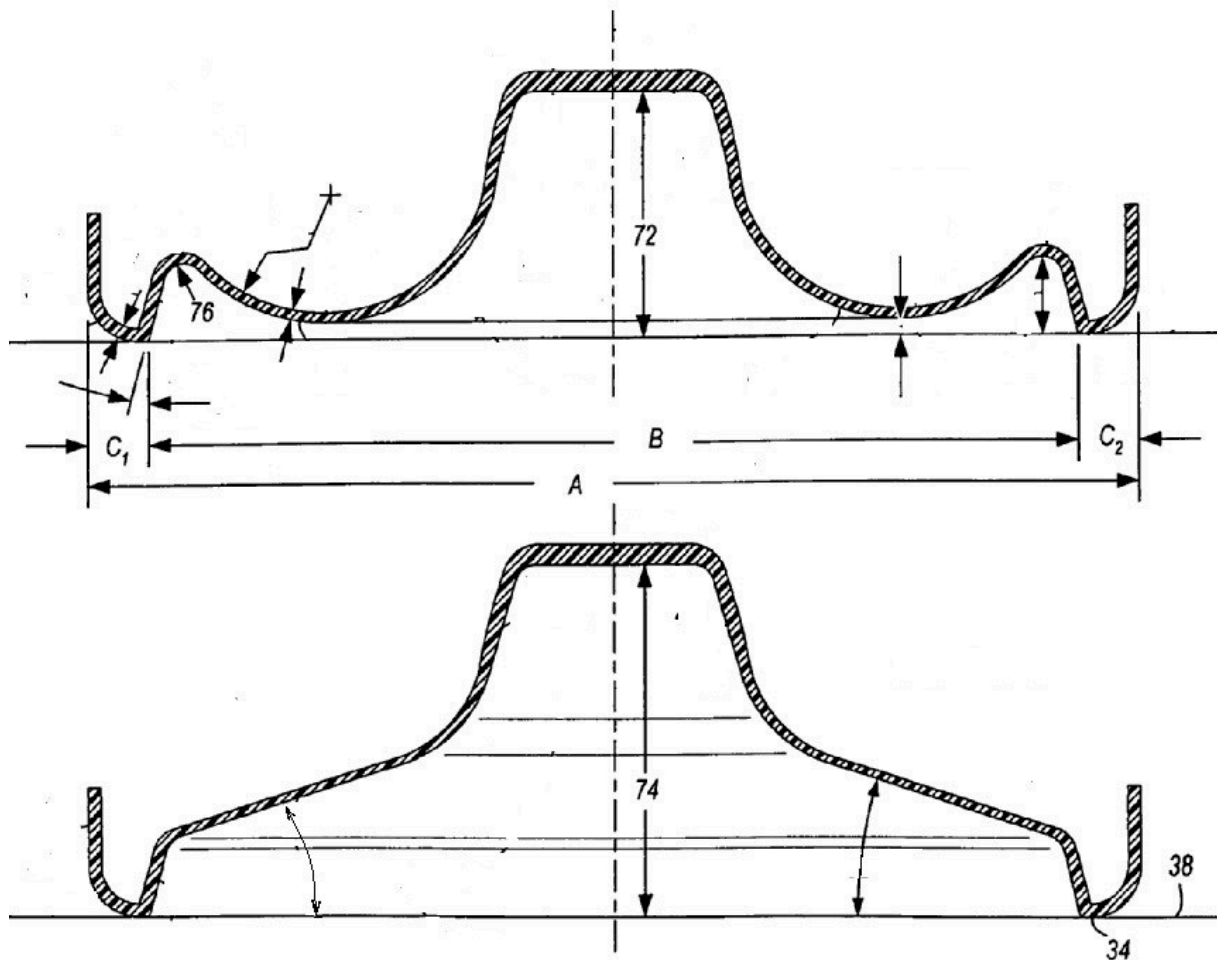

References

Informative references

Attention is drawn to the following places, which may be of interest for search:

Bottom construction of bottles or similar	B65D 1/0261
---	-----------------------------

B65D 79/0084

{in the sidewall or shoulder part thereof}

Definition statement

This place covers:

Illustrative example of subject matter classified in this group.

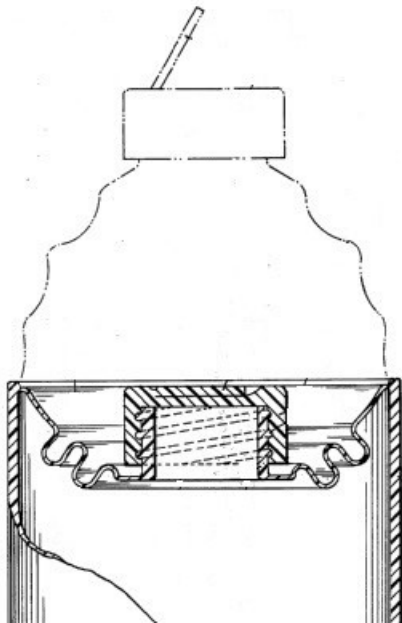

References

Informative references

Attention is drawn to the following places, which may be of interest for search:

Foldable bottles	B65D 1/0292
------------------	-----------------------------

B65D 79/0087

{the deformable part being located in a closure, e.g. in caps or lids}

Definition statement

This place covers:

Illustrative example of subject matter classified in this group.

These type of closures are used, for example, in hot-fill packaging of beverages.

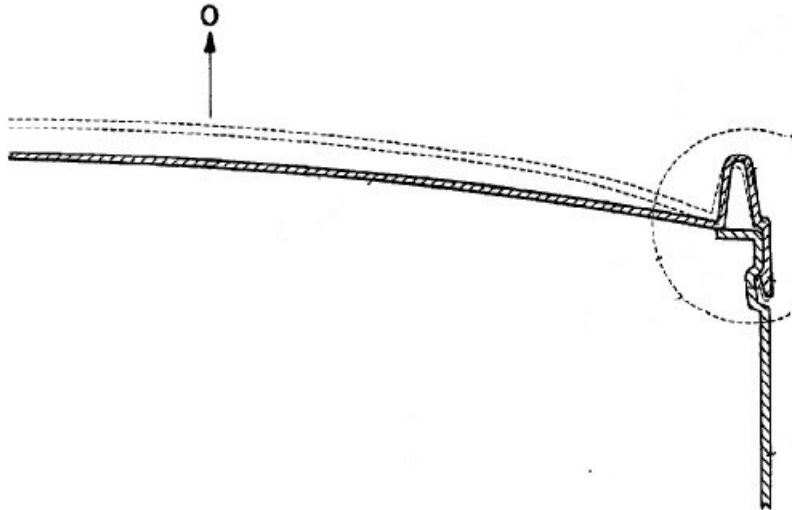

B65D 79/02

Arrangements or devices for indicating incorrect storage or transport (**{B65D 79/005 takes precedence }** ; measuring devices **G01**)

Definition statement

This place covers:

Illustrative example of subject matter classified in this group:

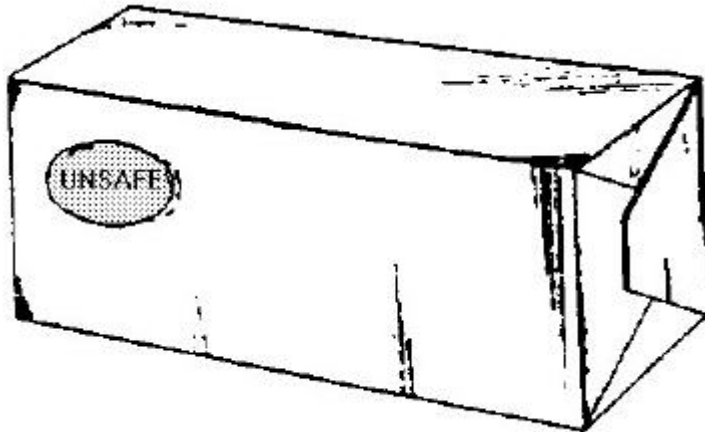

References

Limiting references

This place does not cover:

Tamper-evident devices	B65D 55/02
Containers or closures having deformable parts for indicating or neutralising internal pressure-variations	B65D 79/005
Time or temperature indicators	G01K 3/04
Chemical indicators for investigating time/temperature history	G01N 31/229

B65D 81/00

Containers, packaging elements, or packages, for contents presenting particular transport or storage problems, or adapted to be used for non-packaging purposes after removal of contents

Definition statement

This place covers:

Containers, packaging elements, or packages, for contents presenting particular transport or storage problems, or adapted to be used for non-packaging purposes after removal of contents

B65D 81/022

{Containers made of shock-absorbing material ([B65D 81/03](#) takes precedence; for thermal insulating purposes [B65D 81/3813](#))}

Definition statement

This place covers:

Illustrative example of subject matter classified in this group:

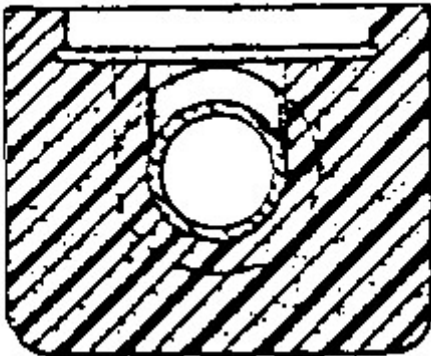
**References****Limiting references**

This place does not cover:

Wrappers or envelopes with shock-absorbing properties	B65D 81/03
---	----------------------------

Special rules of classification

ALSO USED AS Indexing Code

B65D 81/025

{Containers made of sheet-like material and having a shape to accommodate contents}

Definition statement

This place covers:

Illustrative example of subject matter classified in this group:

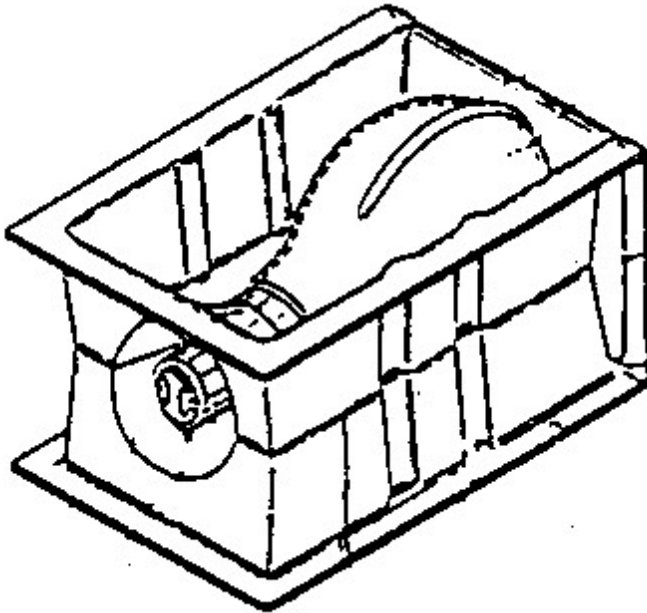

B65D 81/027

{double-walled (for thermal insulating purposes [B65D 81/3818](#), [B65D 81/383](#))}

Definition statement

This place covers:

Illustrative example of subject matter classified in this group:

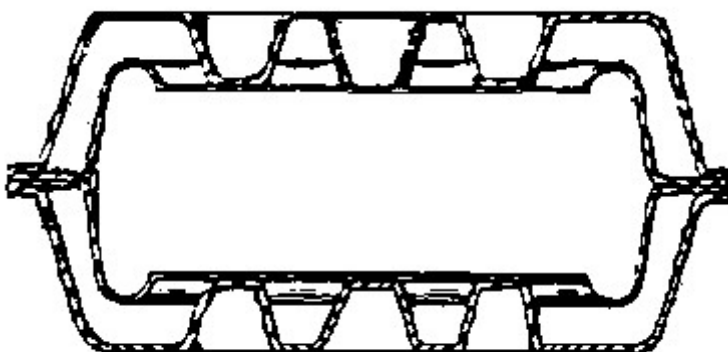

B65D 81/03

Wrappers or envelopes with shock-absorbing properties, e.g. bubble films {(for thermal insulating purposes [B65D 81/3888](#))}

Definition statement

This place covers:

Illustrative example of subject matter classified in this group:

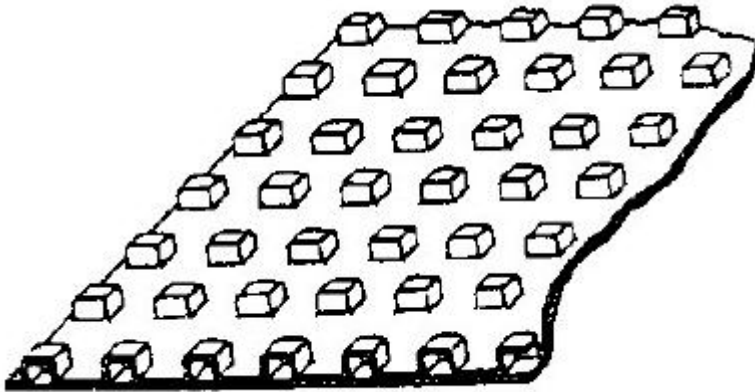
**B65D 81/05**

maintaining contents at spaced relation from package walls, or from other contents ({[B65D 81/022](#), [B65D 81/025](#), } [B65D 81/03](#) take precedence)

References**Limiting references**

This place does not cover:

Made of paper	B65D 5/5035
Containers maintaining the contents in an upright position, e.g. using a gyroscopic system	B65D 81/00
Containers made of shock-absorbing material	B65D 81/022
Containers made of sheet-like material and having a shape to accommodate contents	B65D 81/025
Wrappers or envelopes with shock-absorbing properties	B65D 81/03

B65D 81/051

{using pillow-like elements filled with cushioning material, e.g. elastic foam, fabric}

Definition statement

This place covers:

Illustrative example of subject matter classified in this group:

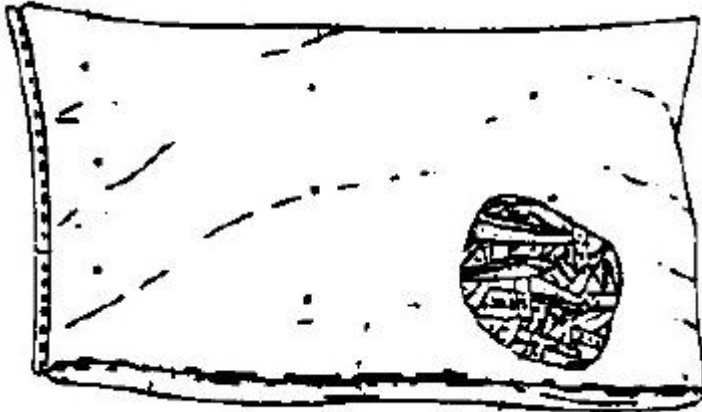
**B65D 81/052**

{filled with fluid, e.g. inflatable elements}

Definition statement

This place covers:

Illustrative example of subject matter classified in this group:

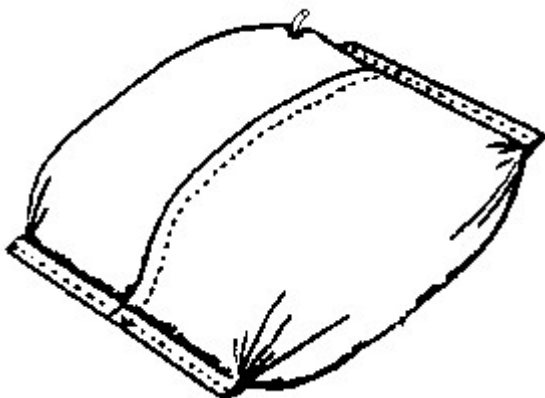
**References****Limiting references**

This place does not cover:

Inflatable fittings for suitcases	A45C 13/02
-----------------------------------	----------------------------

Inflatable mattresses	A47C 27/08
Inflatable pillows	A47G 9/1027

Informative references

Attention is drawn to the following places, which may be of interest for search:

Individual packages cut from webs or tubes containing liquids, semi-liquids, or pastes	B65D 75/48
--	----------------------------

B65D 81/053

{Corner, edge or end protectors}

Definition statement

This place covers:

Illustrative example of subject matter classified in this group:

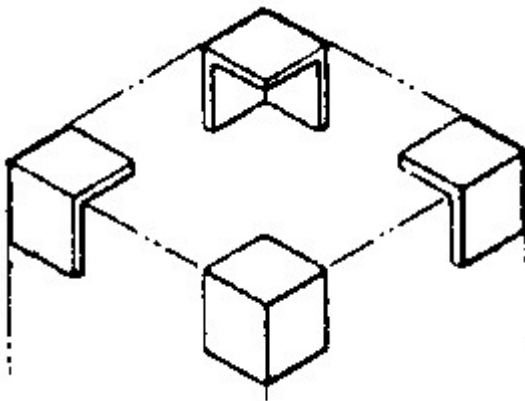

References

Informative references

Attention is drawn to the following places, which may be of interest for search:

Reinforcements formed separately from the container	B65D 5/445
Corner pads or corner posts	B65D 5/5033
Capping elements	B65D 5/5069
Arrangements of flexible binders, with protecting or supporting elements arranged between binder and articles or materials	B65D 71/04

B65D 81/054

{Protectors contacting two generally perpendicular surfaces of the packaged article, e.g. edge protectors ([B65D 81/055](#) takes precedence)}

References**Limiting references**

This place does not cover:

Protectors contacting three surfaces of the packaged article	B65D 81/055
--	-----------------------------

B65D 81/055

{Protectors contacting three surfaces of the packaged article, e.g. three-sided edge protectors ([B65D 81/058](#) takes precedence)}

References**Limiting references**

This place does not cover:

Protectors contacting five surfaces of the packaged article	B65D 81/058
---	-----------------------------

B65D 81/07

using resilient suspension means {([B65D 81/051](#) takes precedence)}

Definition statement

This place covers:

Illustrative example of subject matter classified in this group:

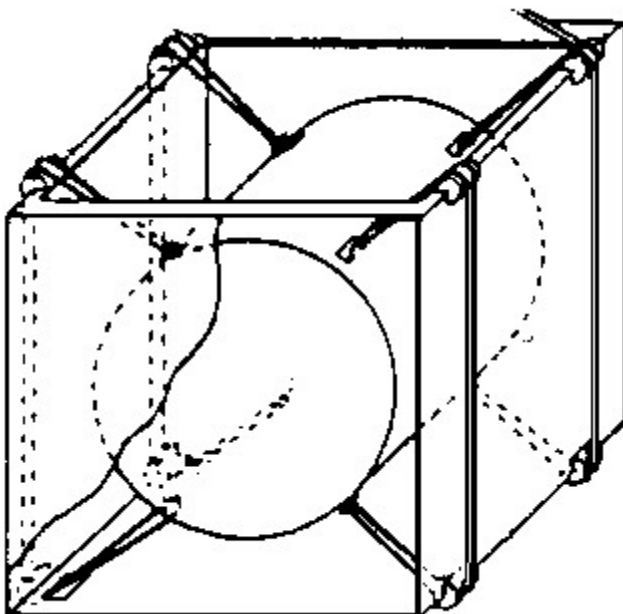

References

Limiting references

This place does not cover:

Internal heat-shrinkable sheets for maintaining the contents in paper boxes	B65D 5/5028
Containers maintaining contents at spaced relation from package walls, or from other contents using pillow-like elements filled with cushioning material	B65D 81/051

B65D 81/075

{the contents being located between two membranes stretched between opposed sides of the package}

Definition statement

This place covers:

Illustrative example of subject matter classified in this group:

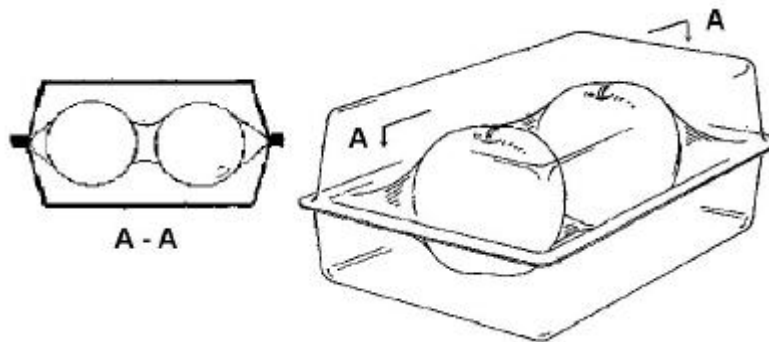

B65D 81/09

using flowable discrete elements of shock-absorbing material, e.g. pellets or popcorn

Definition statement

This place covers:

Illustrative example of subject matter classified in this group:

References

Limiting references

This place does not cover:

Containers maintaining contents at spaced relation from package walls, or from other contents using pillow-like elements filled with cushioning material	B65D 81/051
--	-----------------------------

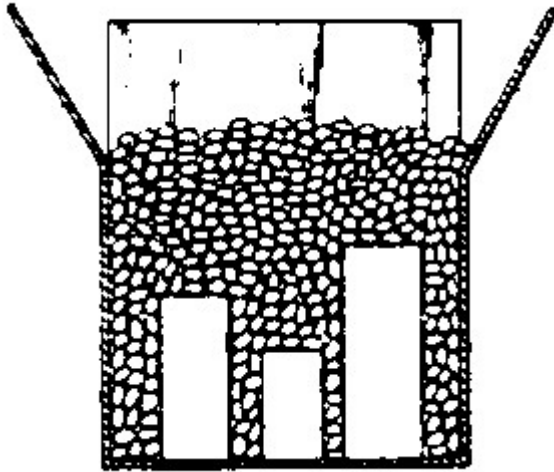

B65D 81/107

using blocks of shock-absorbing material

Definition statement

This place covers:

Illustrative example of subject matter classified in this group:

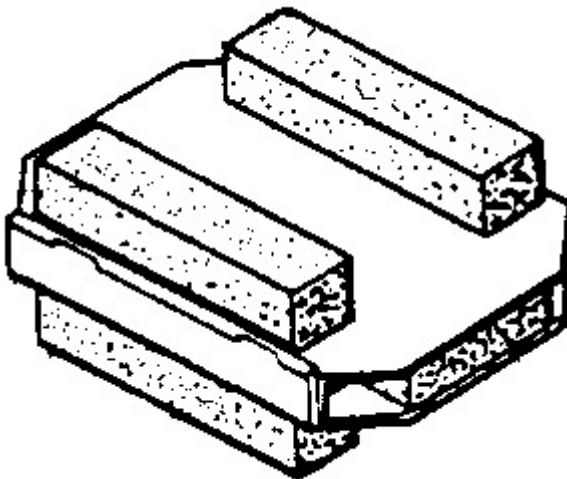

References

Limiting references

This place does not cover:

Blocking the drums of washing machines	D06F 39/001
--	-----------------------------

B65D 81/1075

{deformable to accommodate contents}

Definition statement

This place covers:

Illustrative example of subject matter classified in this group:

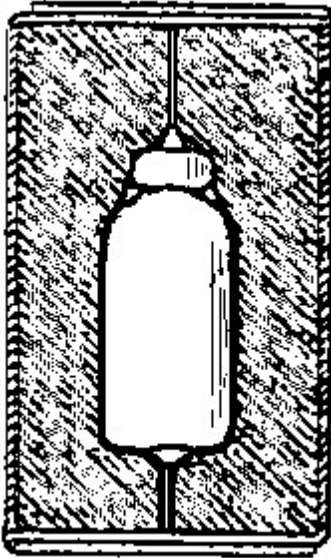

B65D 81/113

of a shape specially adapted to accommodate contents {(B65D 81/053 takes precedence)}

Definition statement

This place covers:

Illustrative example of subject matter classified in this group:

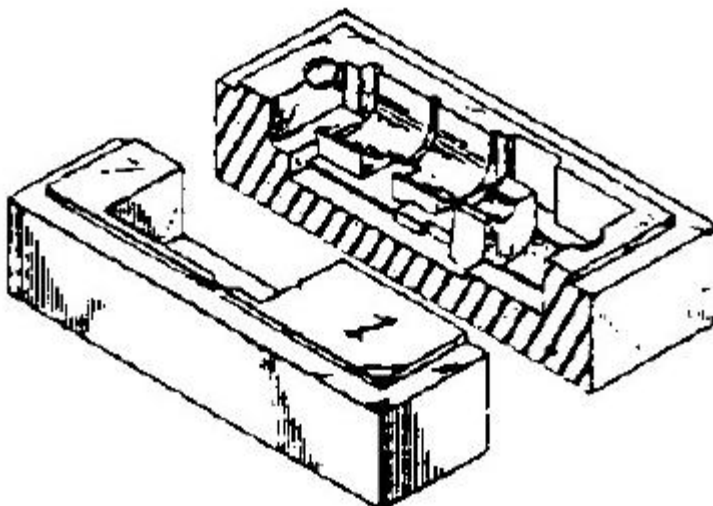

References**Limiting references***This place does not cover:*

Corner, edge or end protectors	B65D 81/053
--------------------------------	-----------------------------

B65D 81/127

using rigid or semi-rigid sheets of shock-absorbing material {([B65D 81/025](#) takes precedence)}

Definition statement*This place covers:*

Illustrative example of subject matter classified in this group:

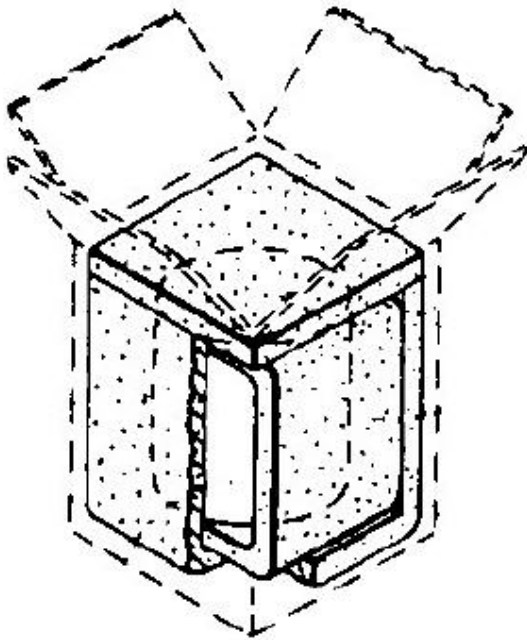
**References****Limiting references***This place does not cover:*

Containers made of sheet-like material and having a shape to accommodate contents	B65D 81/025
---	-----------------------------

B65D 81/1275

{laminated or bonded to the inner wall of a container (for thermal insulating purposes [B65D 81/3858](#))}

Definition statement

This place covers:

Illustrative example of subject matter classified in this group:

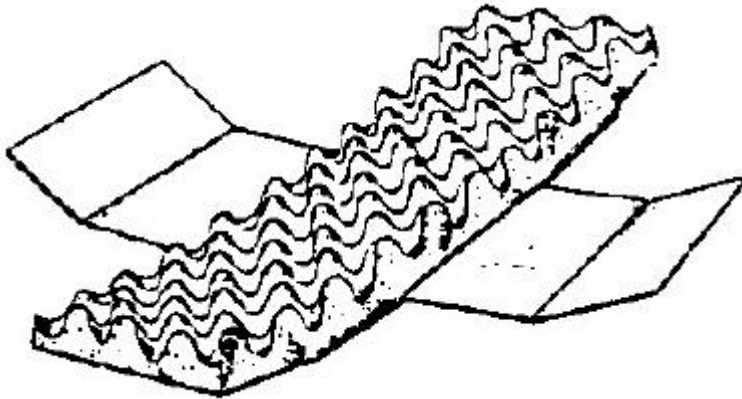
**B65D 81/133**

of a shape specially adapted to accommodate contents, e.g. trays
 {([B65D 81/053](#) takes precedence; thermally insulated trays [B65D 81/3816](#),
[B65D 81/3827](#))}

Definition statement

This place covers:

Illustrative example of subject matter classified in this group:

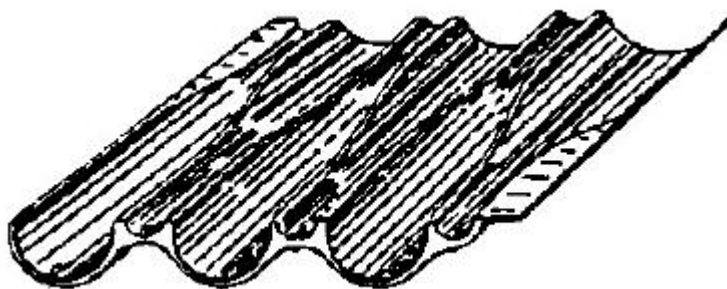
**References****Limiting references**

This place does not cover:

Corner, edge or end protectors	B65D 81/053
--------------------------------	-----------------------------

Informative references

Attention is drawn to the following places, which may be of interest for search:

Tray-like elements formed in one piece	B65D 5/503
Devices to locate articles in containers	B65D 25/10

B65D 81/20

under vacuum or superatmospheric pressure, or in a special atmosphere, e.g. of inert gas {([B65D 81/28](#) takes precedence; containers with pressurising means for maintaining ball pressure [A63B 39/025](#))}

Definition statement

This place covers:

Illustrative example of subject matter classified in this group:

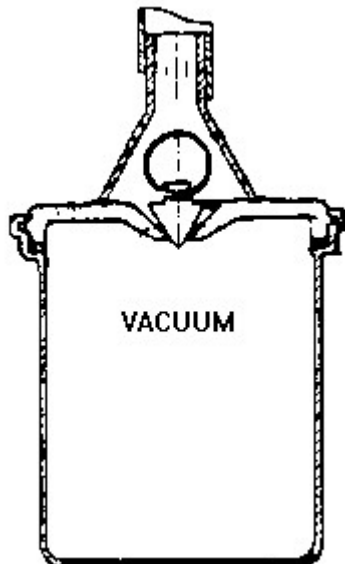
**References****Limiting references**

This place does not cover:

Pressure-relief valves	B65D 31/14 , B65D 77/225
Containers or closures having deformable parts for indicating or neutralising changes of internal pressure	B65D 79/005
Applications of food preservatives, fungicides, pesticides, or animal repellents	B65D 81/28
Pumping means for creating a vacuum or super-pressure	B65B 31/00
Placing in such a container	B65B 31/02

B65D 81/2007

{under vacuum}

References**Limiting references***This place does not cover:*

Containers for several uses, e.g. for contents under vacuum or in a special atmosphere	B65D 81/20
--	----------------------------

B65D 81/2015{in an at least partially rigid container ([B65D 81/2038](#) takes precedence)}**References****Limiting references***This place does not cover:*

Containers for several uses, e.g. for contents under vacuum or in a special atmosphere with means for establishing or improving vacuum	B65D 81/2038
--	------------------------------

B65D 81/2023{in a flexible container ([B65D 81/2038](#) takes precedence)}**References****Limiting references***This place does not cover:*

Containers for several uses, e.g. for contents under vacuum or in a special atmosphere with means for establishing or improving vacuum	B65D 81/2038
--	------------------------------

B65D 81/2046{under superatmospheric pressure ([B65D 81/2069](#) takes precedence)}**References****Limiting references***This place does not cover:*

Containers for several uses, e.g. for contents under vacuum or in a special atmosphere	B65D 81/00
Containers for several uses, e.g. for contents under vacuum and in a special atmosphere	B65D 81/2069

B65D 81/2061**{in a flexible container}****References*****Informative references****Attention is drawn to the following places, which may be of interest for search:*

Flexible containers in rigid containers if the vacuum is in the flexible one	B65D 81/2023
--	------------------------------

B65D 81/2069**{in a special atmosphere}****References*****Limiting references****This place does not cover:*

Containers for several uses, e.g. for contents under vacuum or in a special atmosphere	B65D 81/20
--	----------------------------

B65D 81/22**in moist conditions or immersed in liquids****Definition statement***This place covers:*

Illustrative example of subject matter classified in this group:

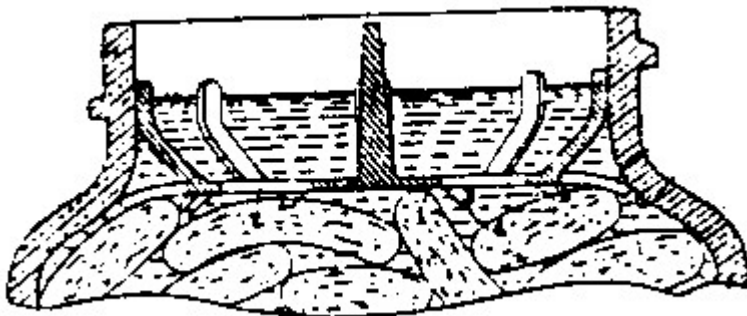
**References*****Informative references****Attention is drawn to the following places, which may be of interest for search:*

Contact lenses immersed in liquid	B65D 2585/545
-----------------------------------	-------------------------------

B65D 81/24

Adaptations for preventing deterioration or decay of contents; Applications to the container or packaging material of food preservatives, fungicides, pesticides or animal repellants (with thermal insulation [B65D 81/38](#))

References

Limiting references

This place does not cover:

Anti-bacterial filters placed on venting apertures in deformable containers	B05B 11/0044 , B05B 11/04
---	--

Informative references

Attention is drawn to the following places, which may be of interest for search:

Inserts or accessories added or joined to the container	B65D 85/1081
---	------------------------------

Synonyms and Keywords

In patent documents, the following words/expressions are often used as synonyms:

- "repellent" and "repellant"

B65D 81/245

{Internal membrane, floating cover or the like isolating the contents from the ambient atmosphere (loosely-attached linings [B65D 25/16](#); dispensing pistons [B65D 83/0005](#); flexible bags for expelling the contents [B65D 83/0055](#))}

Definition statement

This place covers:

Illustrative example of subject matter classified in this group:

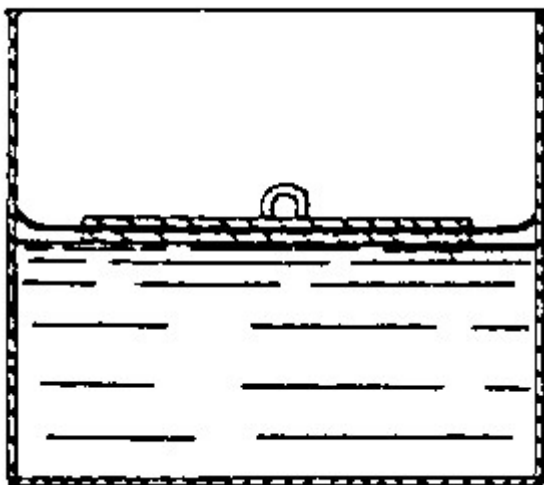

References

Limiting references

This place does not cover:

Floating covers in large containers	B65D 88/34
-------------------------------------	----------------------------

B65D 81/26

with provision for draining away, or absorbing, {or removing by ventilation,} fluids, e.g. exuded by contents {([B65D 33/01](#) takes precedence)}; Applications of corrosion inhibitors or desiccators

References

Limiting references

This place does not cover:

Drainage of bags	B65D 33/01
------------------	----------------------------

B65D 81/261

{for draining or collecting liquids without absorbing them}

Definition statement

This place covers:

Illustrative example of subject matter classified in this group:

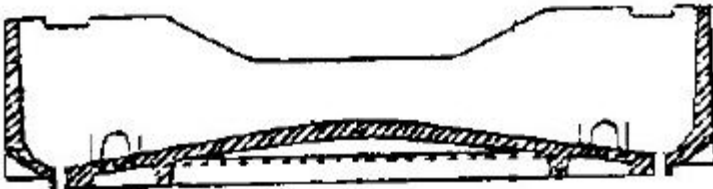

B65D 81/262

{Rigid containers having false bottoms provided with passages for draining and receiving liquids}

Definition statement

This place covers:

Illustrative example of subject matter classified in this group:

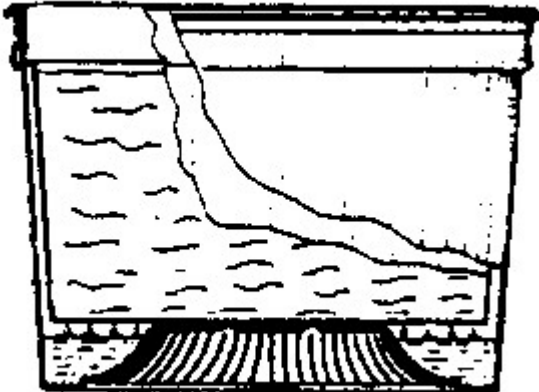

References

Limiting references

This place does not cover:

Adaptations for preventing deterioration or decay of contents with provision for draining away, or absorbing the absorbent being placed beneath a false bottom	B65D 81/265
--	-----------------------------

B65D 81/263

{for ventilating the contents ([B65D 5/4295](#), [B65D 51/1605](#) take precedence)}

Definition statement

This place covers:

Illustrative example of subject matter classified in this group:

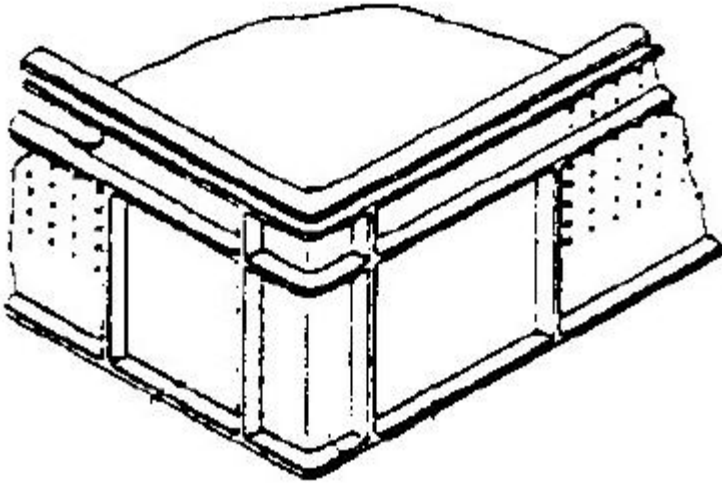
**References****Limiting references**

This place does not cover:

Ventilating arrangements	B65D 5/4295
Means for venting air or gas whereby the interior of the container is maintained in permanent gaseous communication with the exterior	B65D 51/1605

B65D 81/264

{for absorbing liquids}

Definition statement

This place covers:

Illustrative example of subject matter classified in this group:

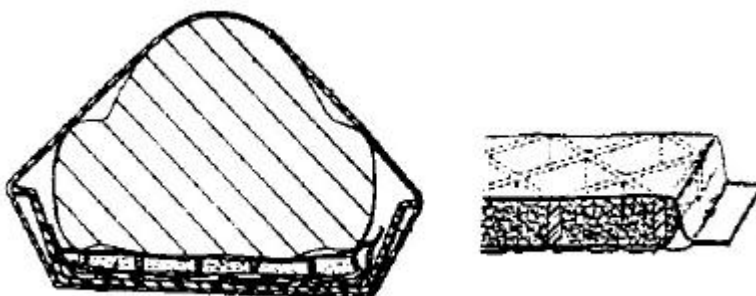

B65D 81/265**{the absorbent being placed beneath a false bottom}****Definition statement***This place covers:*

Illustrative example of subject matter classified in this group:

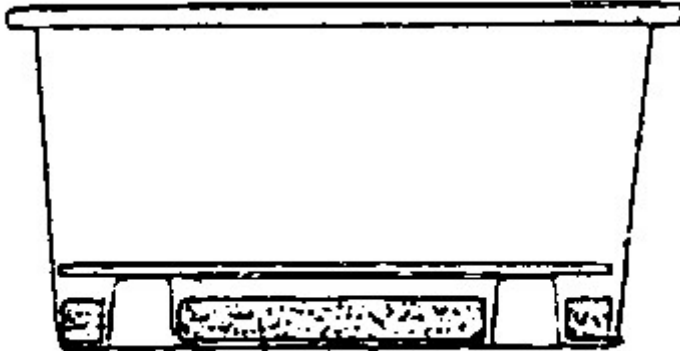
**References****Limiting references***This place does not cover:*

Multilayered containers having an absorbent layer, e.g. trays having an absorbent layer sandwiched between two other layers	B65D 81/264
---	-----------------------------

B65D 81/266**{for absorbing gases, e.g. oxygen absorbers or desiccants ([B65D 51/244](#), [B65D 51/30](#) take precedence)}****References****Limiting references***This place does not cover:*

Closures provided with oxygen absorbers	B65D 51/244
Closures with auxiliary containers for desiccators	B65D 51/30

B65D 81/267

{the absorber being in sheet form}

Definition statement

This place covers:

Illustrative example of subject matter classified in this group:

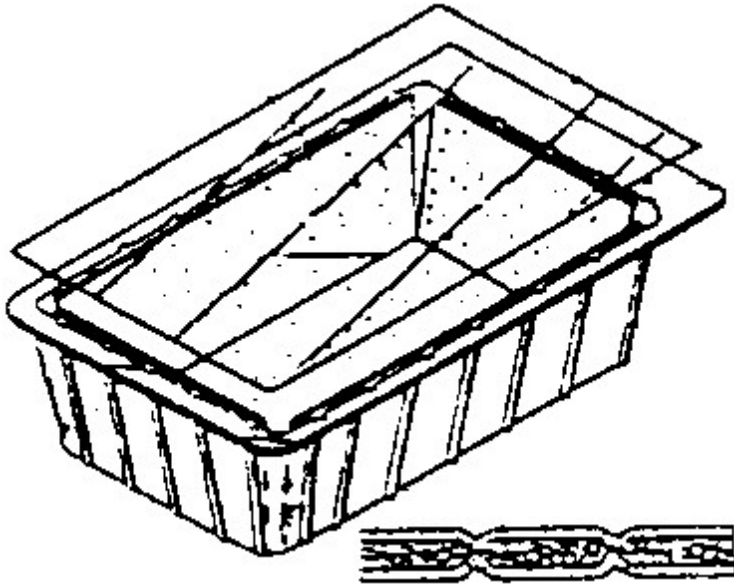

B65D 81/268

{the absorber being enclosed in a small pack, e.g. bag, included in the package}

Definition statement

This place covers:

Illustrative example of subject matter classified in this group:

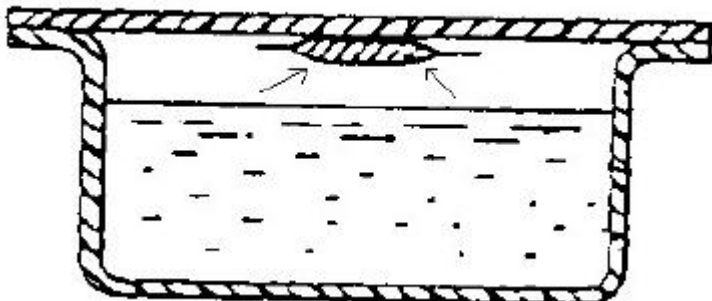

B65D 81/30

by excluding light or other outside radiation (wrappers [B65D 65/16](#))

References**Limiting references**

This place does not cover:

Photographic material	G03C 3/00
Casings of electric apparatus	H05K 9/00

B65D 81/32

for packaging two or more different materials which must be maintained separate prior to use in admixture (containers with removable or destructible partitions [B65D 25/08](#) {; closures combined with auxiliary containers [B65D 51/28](#); in aerosol containers [B65D 83/682](#); amalgam capsules [A61C 5/66](#); containers for pharmaceutical purposes [A61J 1/20](#), [A61M 5/19](#); medical syringes [A61M 3/005](#), resin cartridges for grouting anchoring-bolts in mines [E21D 20/026](#)})

References**Limiting references**

This place does not cover:

Construction of the mixing element per se	B01F
Stirring devices	B01F 33/501
Packaging two or more different substances isolated from one another	B65B 29/10
Partitions formed by a gel	C08J 3/24

Informative references

Attention is drawn to the following places, which may be of interest for search:

Articles joined together for convenience of storage or transport without the use of packaging elements	B65D 69/00
Materials, e.g. different materials, enclosed in separate compartments formed during filling of a single container	B65D 77/08

B65D 81/3205

{Separate rigid or semi-rigid containers joined to each other at their external surfaces ([B65D 81/3288](#) takes precedence)}

Definition statement

This place covers:

Illustrative example of subject matter classified in this group:

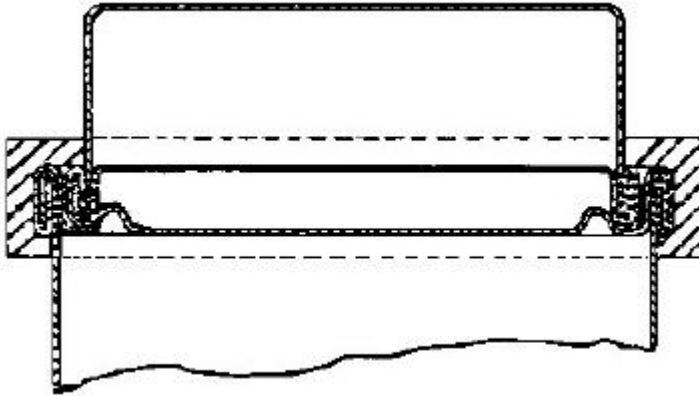
**References****Limiting references**

This place does not cover:

Cylindrical or polygonal containers composed of two or more separate containers joined to each other	B65D 81/3288
--	------------------------------

Informative references

Attention is drawn to the following places, which may be of interest for search:

Auxiliary removable stacking elements other than covers	B65D 21/0224
Rigid or semi-rigid containers provided with a recess in order to be seated on the neck or similar protrusion of a larger container	B65D 21/0238
Coaxial connections	B65D 71/502

B65D 81/3211**{coaxially and provided with means facilitating admixture}****Definition statement***This place covers:*

Illustrative example of subject matter classified in this group:

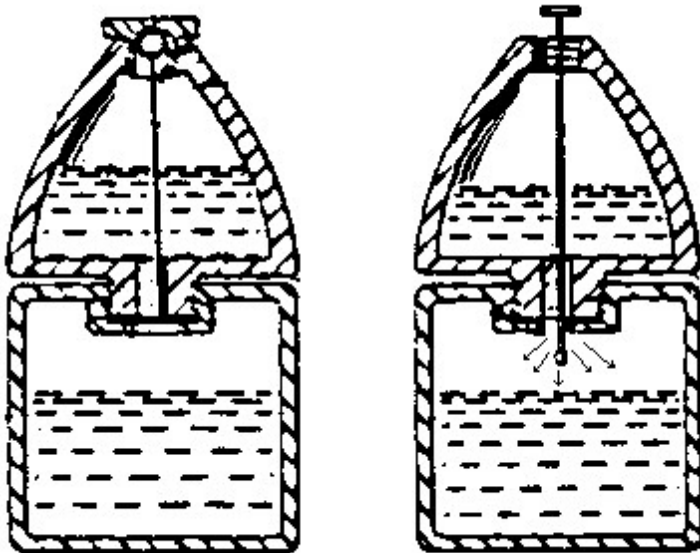
**References****Limiting references***This place does not cover:*

Packages having self-contained heating means, e.g. by mixing two heat generating chemicals	B65D 81/3484
--	------------------------------

Informative references*Attention is drawn to the following places, which may be of interest for search:*

Partitions with provisions for removing or destroying	B65D 25/08
---	----------------------------

B65D 81/3216

{Rigid containers disposed one within the other}

Definition statement

This place covers:

Illustrative example of subject matter classified in this group:

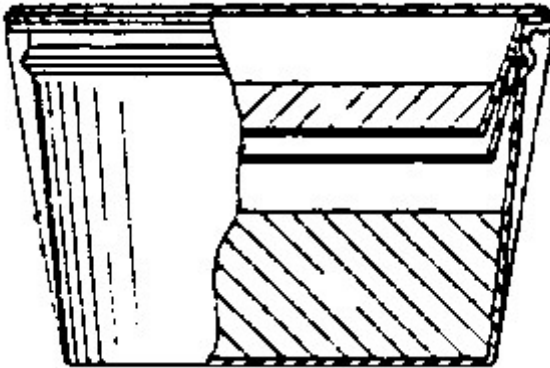

B65D 81/3222

{with additional means facilitating admixture}

Definition statement

This place covers:

Illustrative example of subject matter classified in this group:

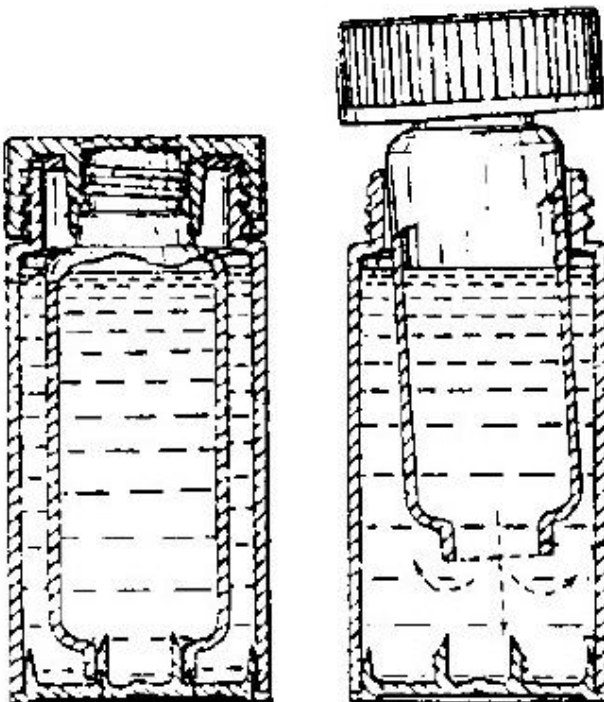

References

Limiting references

This place does not cover:

Packages having self-contained heating means, e.g. by mixing two heat generating chemicals	B65D 81/34
--	----------------------------

Informative references

Attention is drawn to the following places, which may be of interest for search:

Closures presenting means for placing the additional articles or materials in contact with the main contents by acting on a part of the closure without removing the closure	B65D 51/2807
--	------------------------------

B65D 81/3227

{arranged parallel or concentrically and permitting simultaneous dispensing of the two materials without prior mixing ([B65D 81/325](#) takes precedence)}

Definition statement

This place covers:

Illustrative example of subject matter classified in this group:

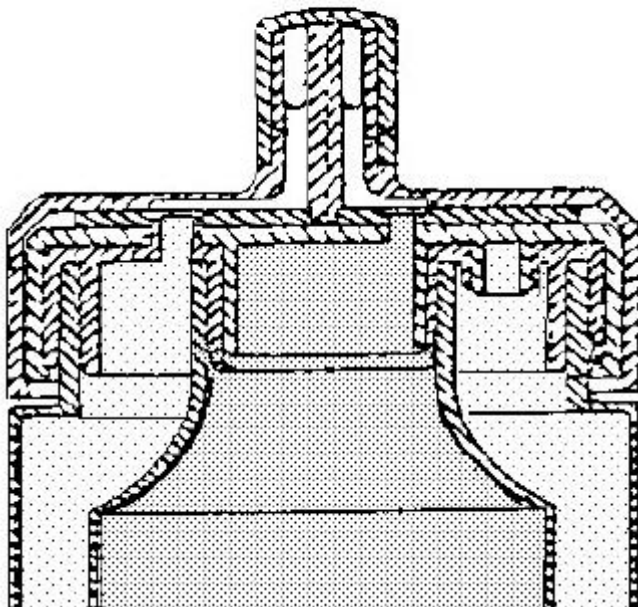

References

Limiting references

This place does not cover:

Construction of the mixing element per se	B01F
---	----------------------

Informative references

Attention is drawn to the following places, which may be of interest for search:

Multi-cavity bottles	B65D 1/04
Pliable tubular containers adapted to be permanently deformed to expel contents with two or more compartments	B65D 35/22
Flexible containers disposed within rigid containers arranged parallel or concentrically and permitting simultaneous dispensing of the two materials without prior mixing	B65D 81/3244
Containers having parallel or coaxial compartments, provided with a piston or a movable bottom for discharging contents	B65D 81/325

B65D 81/3233

{Flexible containers disposed within rigid containers}

Definition statement

This place covers:

Illustrative example of subject matter classified in this group:

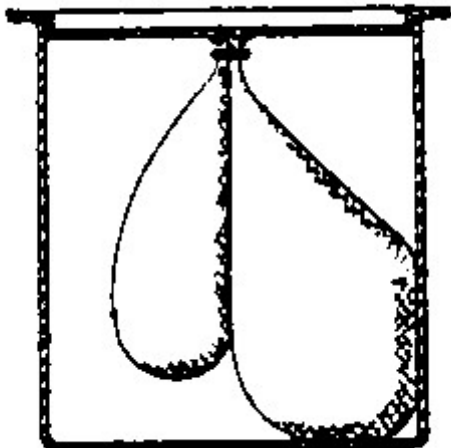

B65D 81/3238

{with additional means facilitating admixture}

Definition statement

This place covers:

Illustrative example of subject matter classified in this group:

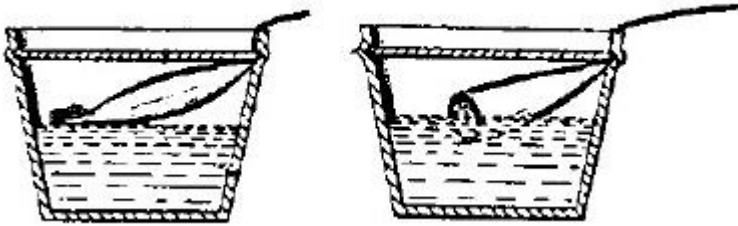

B65D 81/3244

{arranged parallel or concentrically and permitting simultaneous dispensing of the two materials without prior mixing ([B65D 35/22](#), [B65D 81/325](#) take precedence)}

Definition statement

This place covers:

Illustrative example of subject matter classified in this group:

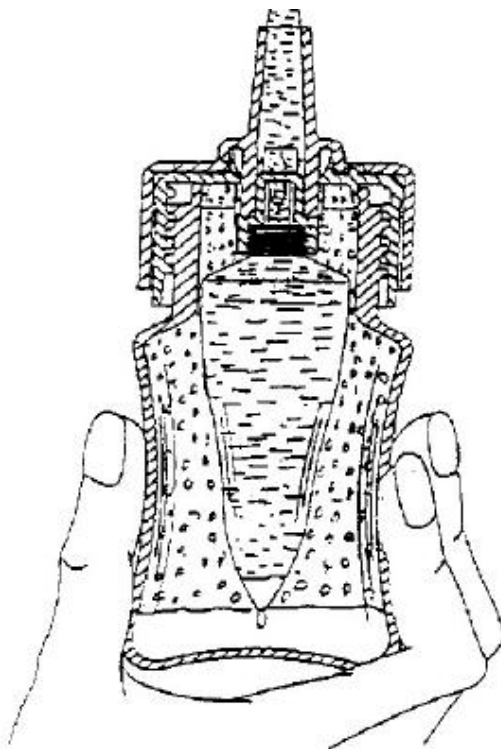

References

Limiting references

This place does not cover:

Pliable tubular containers adapted to be permanently deformed to expel contents with two or more compartments	B65D 35/22
Containers having parallel or coaxial compartments, provided with a piston or a movable bottom for discharging contents	B65D 81/325

Informative references

Attention is drawn to the following places, which may be of interest for search:

Multi-cavity bottles	B65D 1/04
Rigid containers disposed one within the other arranged parallel or concentrically and permitting simultaneous dispensing of the two materials without prior mixing	B65D 81/3227

B65D 81/325

{Containers having parallel or coaxial compartments, provided with a piston or a movable bottom for discharging contents}

Definition statement

This place covers:

Illustrative example of subject matter classified in this group:

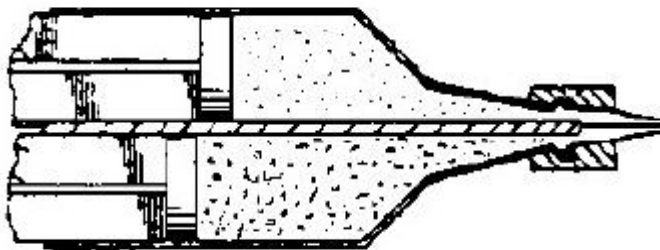

References

Limiting references

This place does not cover:

Construction of the mixing element per se	B01F
---	----------------------

Informative references

Attention is drawn to the following places, which may be of interest for search:

Rigid containers disposed one within the other arranged parallel or concentrically and permitting simultaneous dispensing of the two materials without prior mixing	B65D 81/3227
---	------------------------------

Flexible containers disposed within rigid containers arranged parallel or concentrically and permitting simultaneous dispensing of the two materials without prior mixing	B65D 81/3244
Cylindrical or polygonal containers	B65D 81/3283
Movable or transportable mixing devices or plants	B01F 33/50
Hand tools or apparatus using hand held tools with means allowing the stock of material to consist of at least two different components	B05C 17/00553

B65D 81/3255

{Containers provided with a piston or a movable bottom, and permitting admixture within the container}

Definition statement

This place covers:

Illustrative example of subject matter classified in this group:

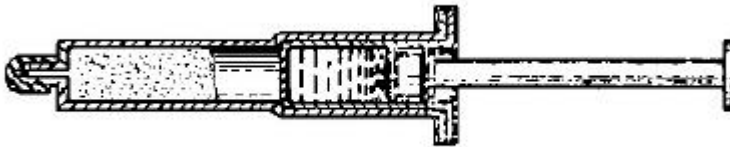

B65D 81/3261

{Flexible containers having several compartments}

Definition statement

This place covers:

Illustrative example of subject matter classified in this group:

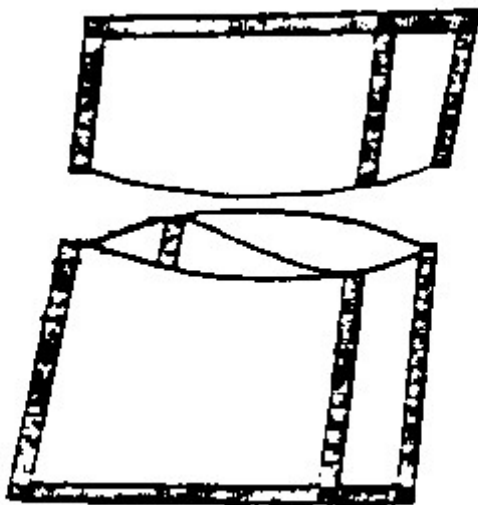

References

Limiting references

This place does not cover:

Packages having self-contained heating means, e.g. by mixing two heat generating chemicals	B65D 81/3484
--	------------------------------

B65D 81/3266

{separated by a common rupturable seal, a clip or other removable fastening device}

Definition statement

This place covers:

Illustrative example of subject matter classified in this group:

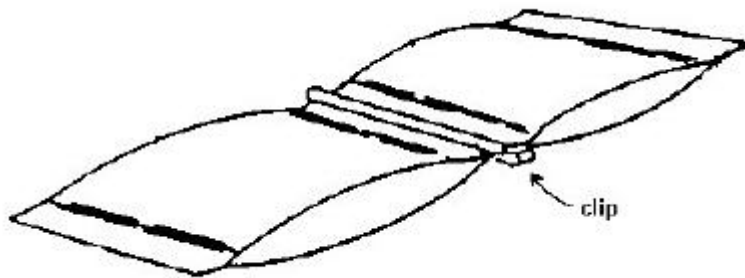

References

Limiting references

This place does not cover:

For clips	B65D 33/1658
Releasable fastenings clips	F16B 2/20

B65D 81/3272

{formed by arranging one flexible container within another}

Definition statement

This place covers:

Illustrative example of subject matter classified in this group:

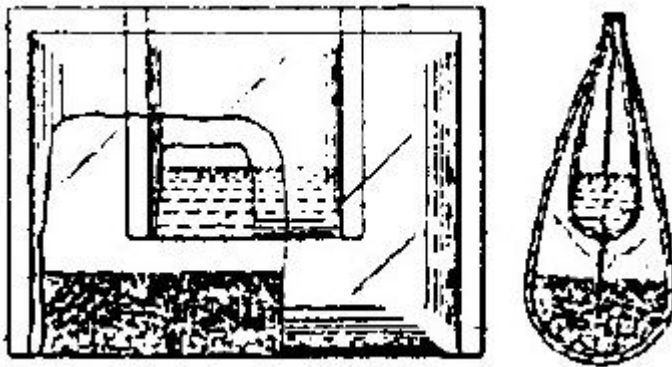

B65D 81/3277

{Ampoules}

Definition statement

This place covers:

Illustrative example of subject matter classified in this group:

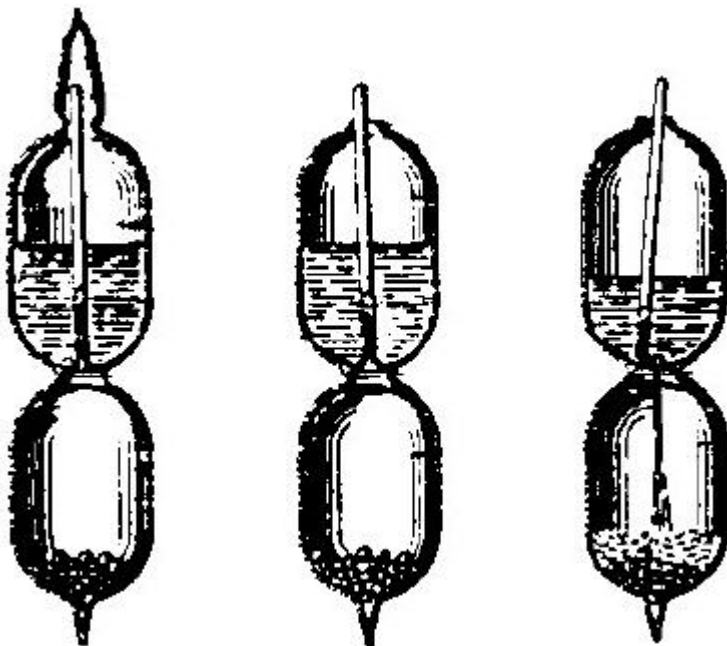

B65D 81/3283

{Cylindrical or polygonal containers, e.g. bottles, with two or more substantially axially offset, side-by-side compartments for simultaneous dispensing ([B65D 35/22](#), [B65D 35/242](#), [B65D 81/3227](#), [B65D 81/325](#) take precedence)}

Definition statement

This place covers:

Illustrative example of subject matter classified in this group:

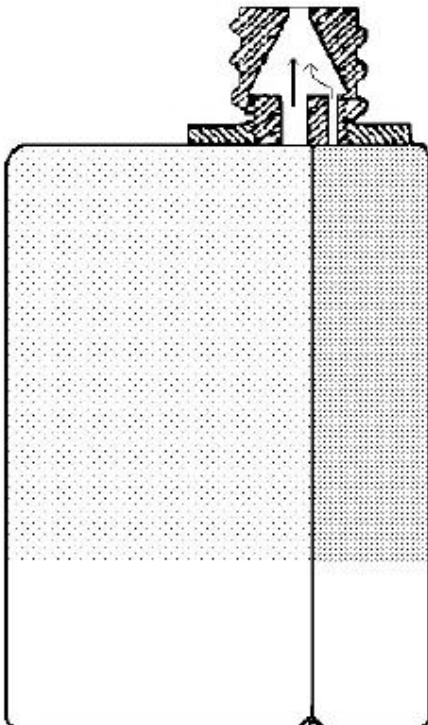

References

Limiting references

This place does not cover:

Pliable tubular containers adapted to be permanently deformed to expel contents with two or more compartments	B65D 35/22
Pliable tubular containers adapted to be permanently or temporarily deformed to expel contents, for mixing or discharging of two or more components	B65D 35/242
Rigid containers disposed one within the other arranged parallel or concentrically and permitting simultaneous dispensing of the two materials without prior mixing	B65D 81/3227
Containers having parallel or coaxial compartments, provided with a piston or a movable bottom for discharging contents	B65D 81/325
Ampoules	B01D1/09
Construction of the mixing element per se	B01F

Informative references

Attention is drawn to the following places, which may be of interest for search:

Multi-cavity bottles	B65D 1/04
----------------------	---------------------------

B65D 81/3288

{composed of two or more separate containers joined to each other}

References**Informative references**

Attention is drawn to the following places, which may be of interest for search:

Multi-cavity bottles	B65D 1/04
Containers, stackable or joined together side-by-side	B65D 21/0201
Articles joined together for convenience of storage or transport without the use of packaging elements	B65D 69/00
Containers having parallel or coaxial compartments, provided with a piston or a movable bottom for discharging contents	B65D 81/325

B65D 81/3294

{Thermoformed trays or the like with a plurality of recesses for different materials located in different recesses}

Definition statement

This place covers:

Illustrative example of subject matter classified in this group:

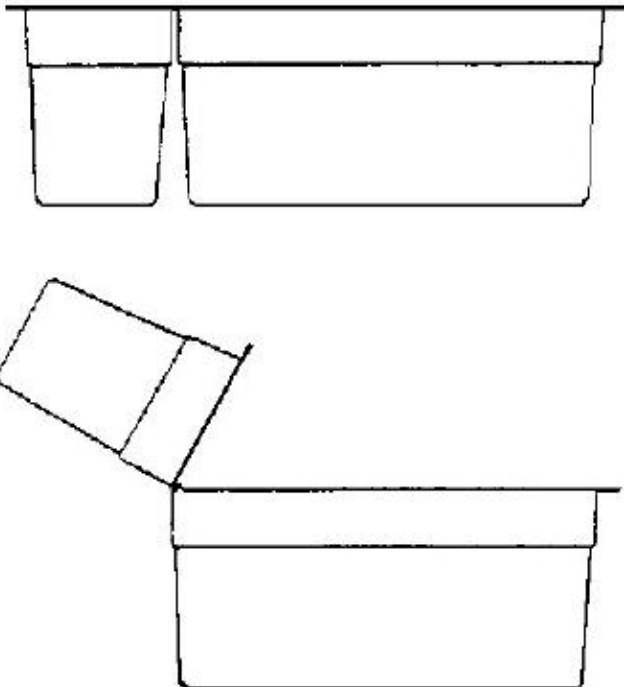
**References****Informative references**

Attention is drawn to the following places, which may be of interest for search:

Trays or like shallow containers with moulded compartments or partitions	B65D 1/36
Articles or materials enclosed between two opposed sheets or blanks having their margins united and having several recesses to accommodate a series of articles or quantities of material	B65D 75/34

B65D 81/34

for packaging foodstuffs {or other articles} intended to be cooked or heated within the package

References**Limiting references**

This place does not cover:

Containers specified for microwaves	B65D 81/3446
-------------------------------------	------------------------------

Treatment or preparation of food or foodstuffs	A23L
Combination stirring device & package	A47G 19/00
Combination spoon & packaging container	A47G 21/00 , A47J36/0004
Holders for fast food, e.g. pizza slice	A47G 21/001
Cooking or baking vessels or supports for using only once	A47J 36/022
Packaging of edible materials intended to be cooked in the package	B65B 29/08
Inserted devices for cooling	F25D
Chemical indicators for investigating time/temperature history	G01N 31/229
Inserted devices for cooking	

B65D 81/3407

{specially adapted to be heated over a heat source, e.g. a hob, campfire}

Definition statement

This place covers:

Illustrative example of subject matter classified in this group:

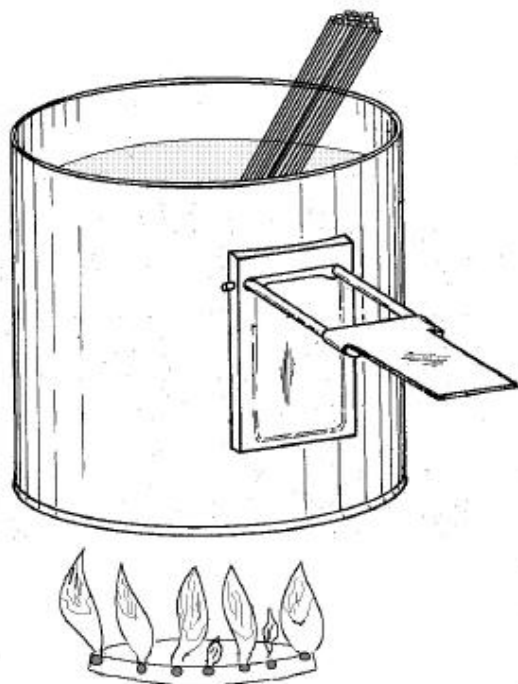

B65D 81/3415

{specially adapted to be heated in hot water, e.g. boil pouches (dissolvable packages [B65D 65/46](#); packaging articles or materials intended to be mixed or infused with a liquid [B65D 85/808](#))}

Definition statement

This place covers:

Illustrative example of subject matter classified in this group:

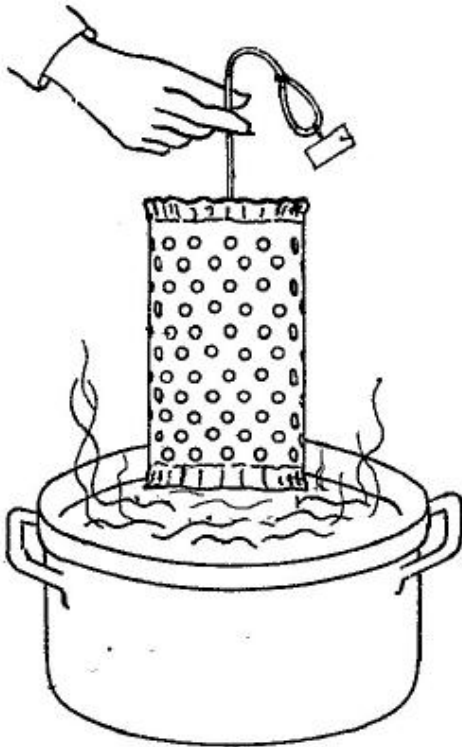

B65D 81/3423

{Packages shrinking in hot water, e.g. for boiling hams}

Definition statement

This place covers:

Illustrative example of subject matter classified in this group:

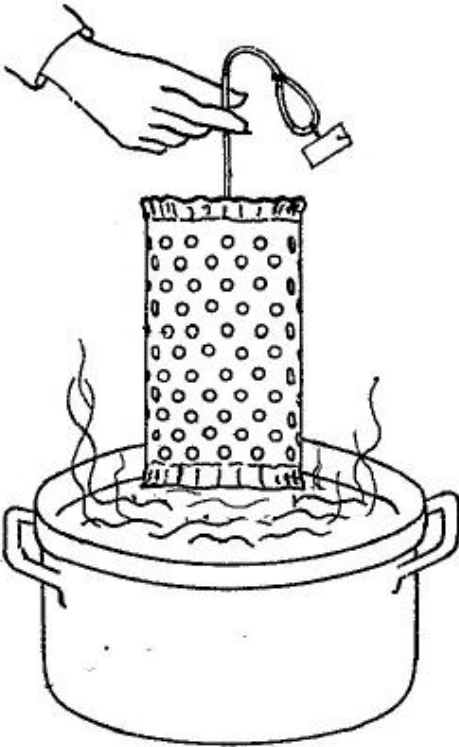
**References****Limiting references**

This place does not cover:

Packaging for cooking ham	B65D 2581/342
---------------------------	-------------------------------

B65D 81/343

{specially adapted to be heated in a conventional oven, e.g. a gas or electric resistance oven}

References**Limiting references**

This place does not cover:

Dual-ovenable containers, i.e. for use in a conventional or microwave oven	B65D 81/343 , B65D 81/3446 , B65D 81/3453 , B65D 81/3461
--	---

B65D 81/3438

{specially adapted to be heated by steaming}

Definition statement

This place covers:

Illustrative example of subject matter classified in this group:

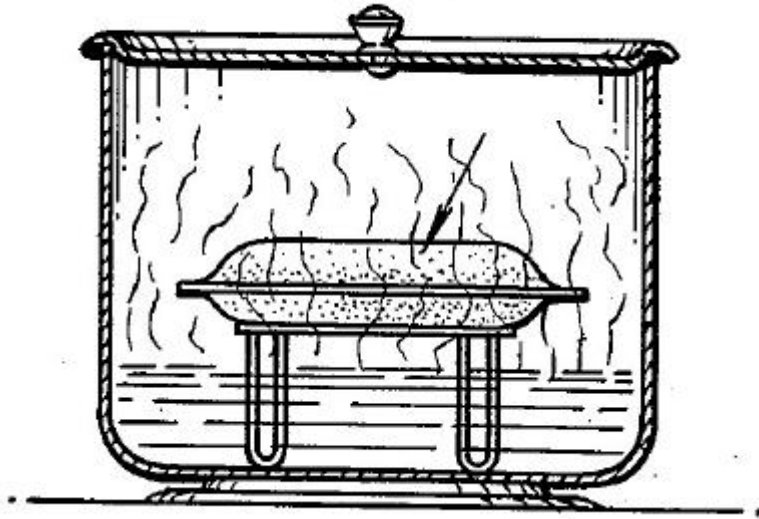

B65D 81/3446

{specially adapted to be heated by microwaves}

Definition statement

This place covers:

Illustrative example of subject matter classified in this group:

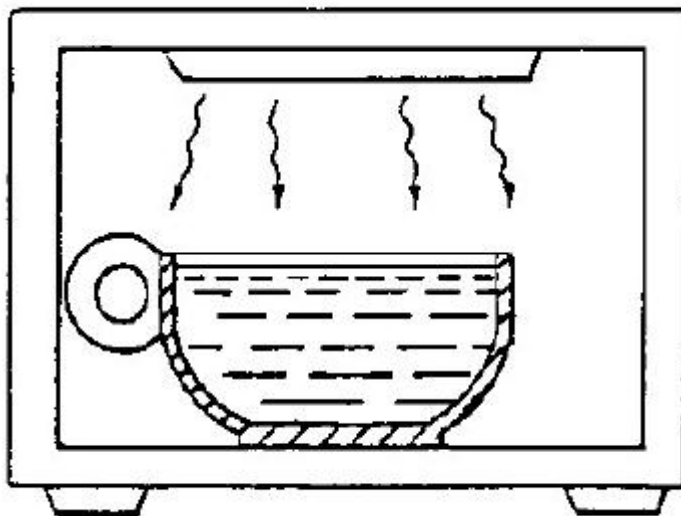

References

Limiting references

This place does not cover:

Dualovenable containers, i.e. for use in a conventional or microwave oven	B65D 81/343 , B65D 81/3446 , B65D 81/3453 , B65D 81/3461
---	---

B65D 81/3453

{Rigid containers, e.g. trays, bottles, boxes, cups}

References

Limiting references

This place does not cover:

Water boiling vessels using MW energy	A47J 31/547
Cooking or baking-vessels specially adapted for use in MW oven	A47J 36/027

B65D 81/3469

{Pop-corn bags}

Definition statement

This place covers:

Illustrative example of subject matter classified in this group:

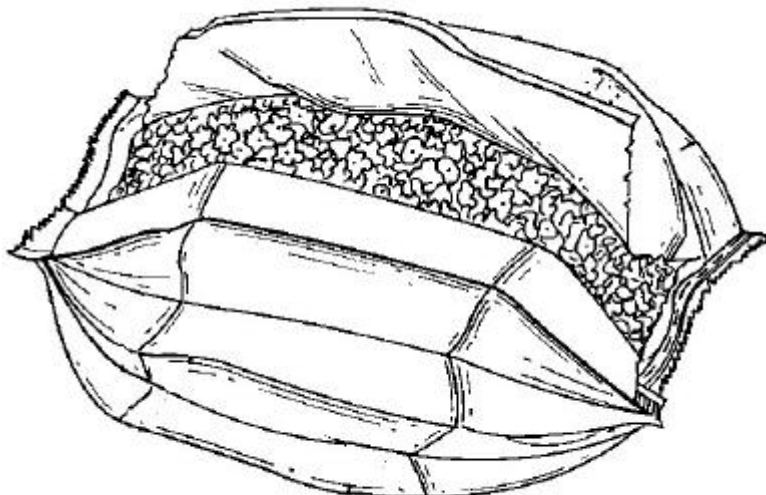

References

Limiting references

This place does not cover:

Making puffed cereals by heating without pressure release, e.g. pop corn, puffed rice	A23L 7/161
---	----------------------------

B65D 81/3476

{Packages provided with an electrical circuit, e.g. resistances, for heating the contents (microwave susceptors [B65D 2581/3463](#))}

Definition statement

This place covers:

Illustrative example of subject matter classified in this group:

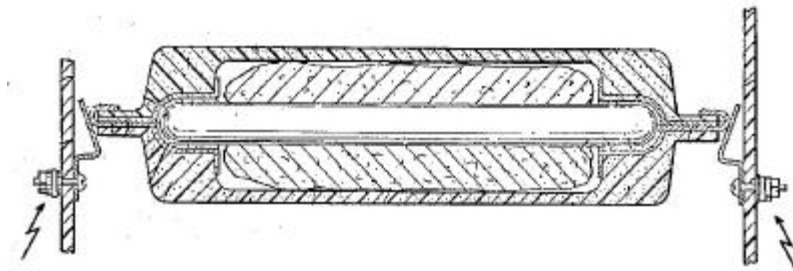

B65D 81/3484

{Packages having self-contained heating means, e.g. heating generated by the reaction of two chemicals (warming devices [A47J 36/24](#))}

Definition statement

This place covers:

Illustrative example of subject matter classified in this group:

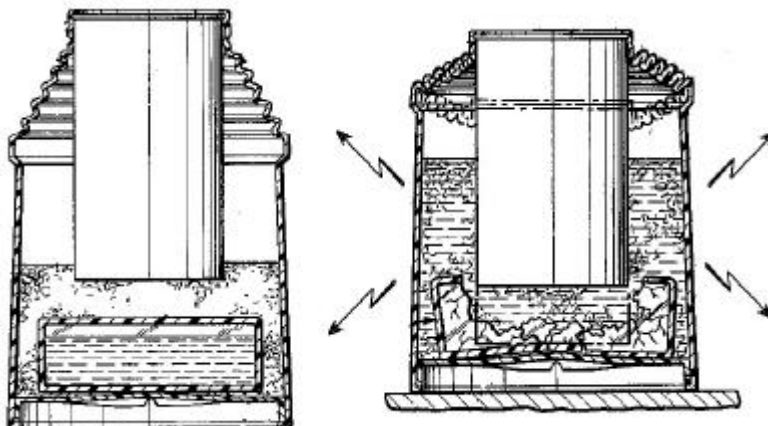

References

Limiting references

This place does not cover:

Rigid containers disposed one within the other	B65D 81/3216
Materials for the production of heat or cold by chemical reactions other than combustion	C09K 5/00
Apparatus or devices using heat produced by exothermal chemical reactions other than by combustion	F24V 30/00
Bottles and cans having self-contained cooling means	F25D 31/007

B65D 81/3492

{specially adapted to be heated in a toaster}

Definition statement

This place covers:

Illustrative example of subject matter classified in this group:

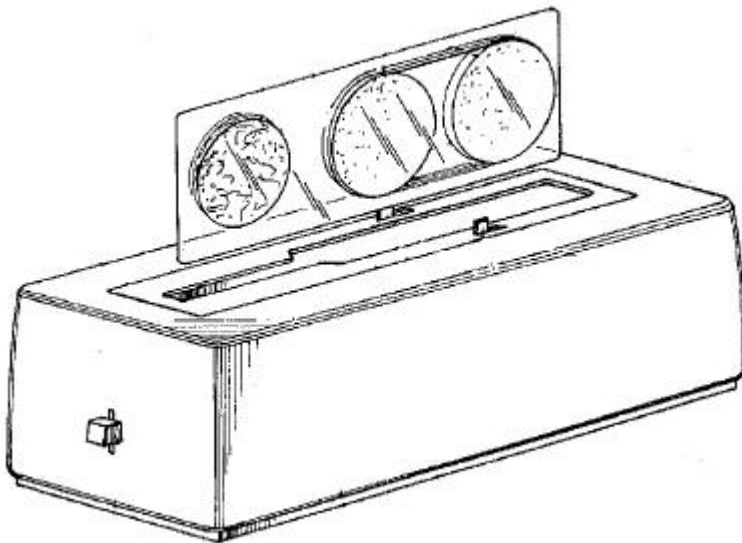

B65D 81/36

adapted to be used for non-packaging purposes after removal of contents

References

Limiting references

This place does not cover:

Combination stirring device & package	A47G 19/00
Holder or wrappers as eating aids for fast food, e.g. hamburgers	A47G 21/001
Combination spoon & packaging container	A47G 21/04
Oil cans for the collection of used oil	F16N 31/002

B65D 81/361

{Modular elements with complementary shapes, interengageable parts or the like (toy building blocks [A63H 33/04](#); building elements for walls [E04B 2/02](#))}

Definition statement

This place covers:

Illustrative example of subject matter classified in this group:

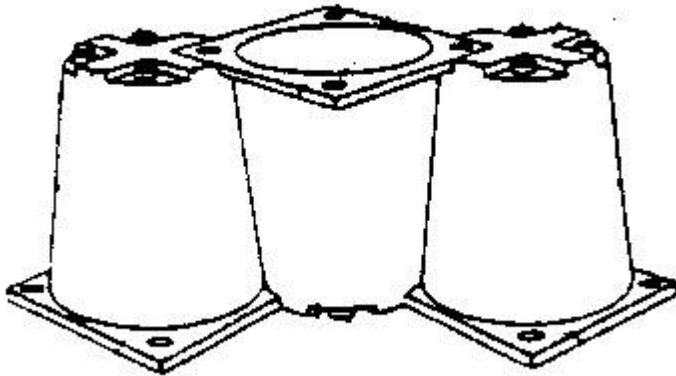

References

Informative references

Attention is drawn to the following places, which may be of interest for search:

Containers of variable capacity by means of additional elements	B65D 21/083
---	-----------------------------

B65D 81/363

{Containers forming or being transformable into items of wearing apparel, e.g. shirt, apron, hat}

Definition statement

This place covers:

Illustrative example of subject matter classified in this group:



B65D 81/365

{Containers, or parts thereof, simulating or being incorporated into other items, e.g. puppet, animal, vehicle, building, dumb bells ([B65D 81/363](#), [B65D 81/368](#) take precedence)}

Definition statement

This place covers:

Illustrative example of subject matter classified in this group:

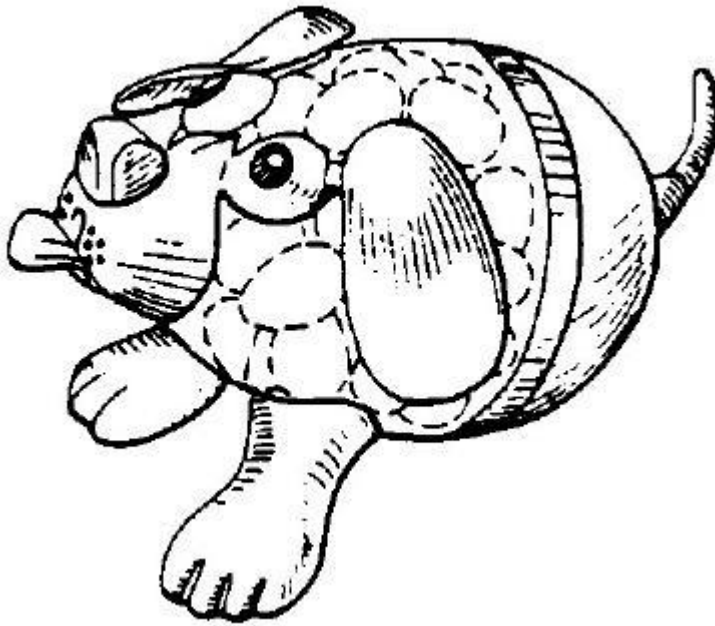
**References****Limiting references**

This place does not cover:

Containers forming or being transformable into items of wearing apparel	B65D 81/363
Foldable carton-boxes simulating, or transformable into, a special configuration	B65D 81/368

B65D 81/366

{the container closure only being provided with a three dimensional figure, e.g. chess piece, animal}

Definition statement

This place covers:

Illustrative example of subject matter classified in this group:

**References****Informative references**

Attention is drawn to the following places, which may be of interest for search:

Closures provided with decoration, information or contents indicating devices, labels	B65D 51/245
Special configurations relating to container closures	B65D 2251/06

B65D 81/368

{Foldable carton-boxes simulating, or transformable into, a special configuration, e.g. a car, a house, an animal (cartons with spaced apart images to give a 3-D effect [B65D 5/4258](#); toy models made by folding paper [A63H 33/16](#))}

Definition statement

This place covers:

Illustrative example of subject matter classified in this group:

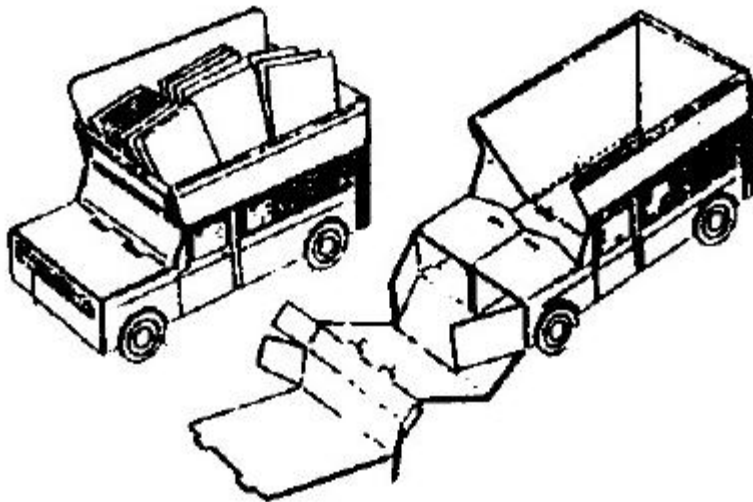
**B65D 81/38**

with thermal insulation (vacuum bottles or the like [A47J 41/00](#) {; thermal insulation of domestic water storage heaters [F24H 1/182](#)})

References**Limiting references**

This place does not cover:

Insulated bags	B65D 31/04
----------------	----------------------------

B65D 81/3806

{formed with double walls, i.e. hollow}

Definition statement

This place covers:

Illustrative example of subject matter classified in this group:

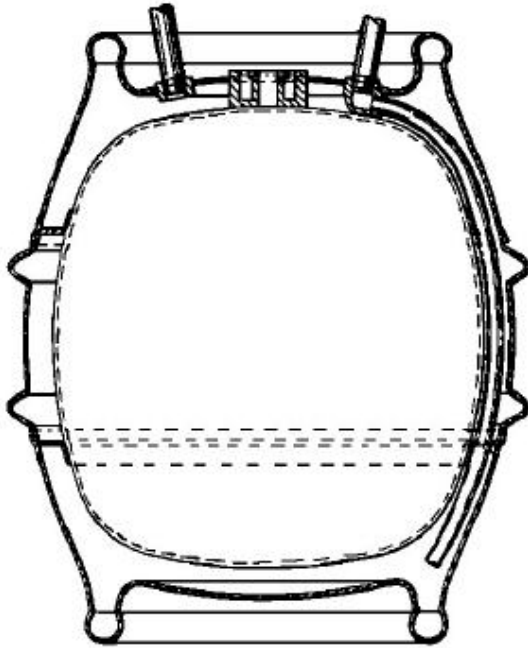

B65D 81/3811

{formed of different materials, e.g. laminated or foam filling between walls}

Definition statement

This place covers:

Illustrative example of subject matter classified in this group:

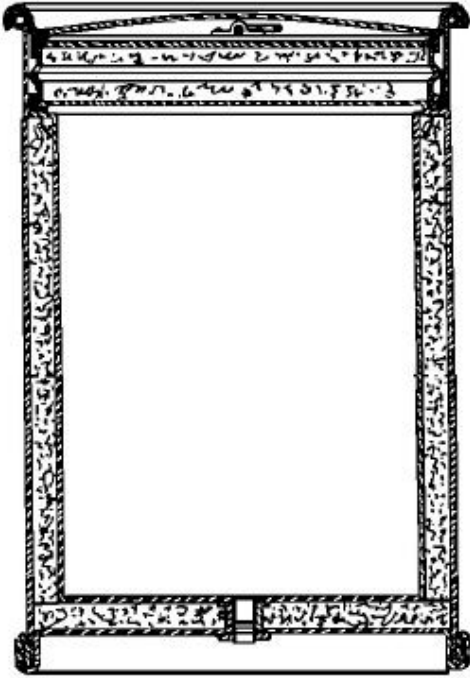

B65D 81/3816

{formed of foam material}

Definition statement

This place covers:

Illustrative example of subject matter classified in this group:



B65D 81/3818

{formed with double walls, i.e. hollow}

Definition statement

This place covers:

Illustrative example of subject matter classified in this group:

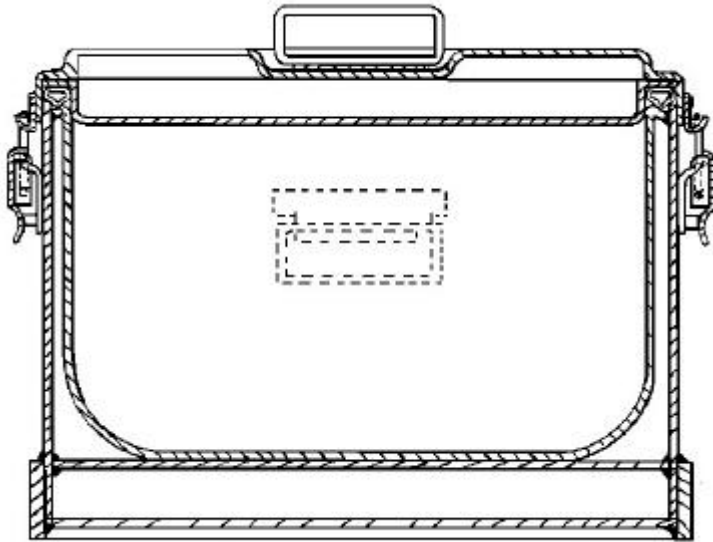

B65D 81/382

{provided with liquid material between double walls}

Definition statement

This place covers:

Illustrative example of subject matter classified in this group:

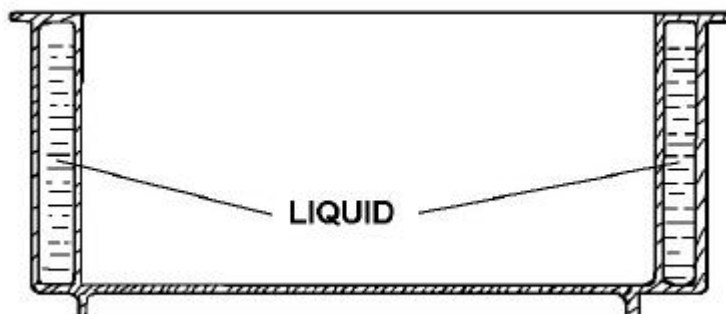

B65D 81/3823

{formed of different materials, e.g. laminated or foam filling between walls}

Definition statement

This place covers:

Illustrative example of subject matter classified in this group:

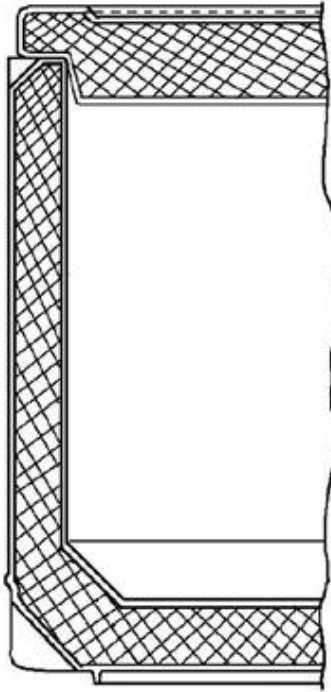
**B65D 81/3825**

{rigid container being in the form of a box, tray or like container with one or more containers located inside the external container}

References***Informative references***

Attention is drawn to the following places, which may be of interest for search:

Serving trays with means for keeping food cool or hot	A47G 23/0683
Dish-warmers; devices to keep food hot	A47J 39/02

B65D 81/3827**{the external tray being formed of foam material}****Definition statement***This place covers:*

Illustrative example of subject matter classified in this group:

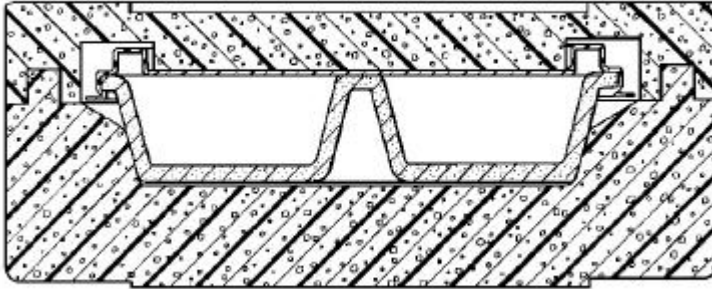
**References****Informative references***Attention is drawn to the following places, which may be of interest for search:*

Serving trays with means for keeping food cool or hot	A47G 23/0683
Dish-warmers; devices to keep food hot	A47J 39/02

B65D 81/383**{the external tray being formed with double walls, i.e. hollow}****References****Informative references***Attention is drawn to the following places, which may be of interest for search:*

Serving trays with means for keeping food cool or hot	A47G 23/0683
---	------------------------------

B65D 81/3832**{the external tray being provided with liquid material between double walls}****References****Informative references***Attention is drawn to the following places, which may be of interest for search:*

Serving trays with means for keeping food cool or hot	A47G 23/0683
Dish-warmers; devices to keep food hot	A47J 39/02

B65D 81/3834

{the external tray being formed of different materials, e.g. laminated or foam filling between walls}

Definition statement

This place covers:

Illustrative example of subject matter classified in this group:

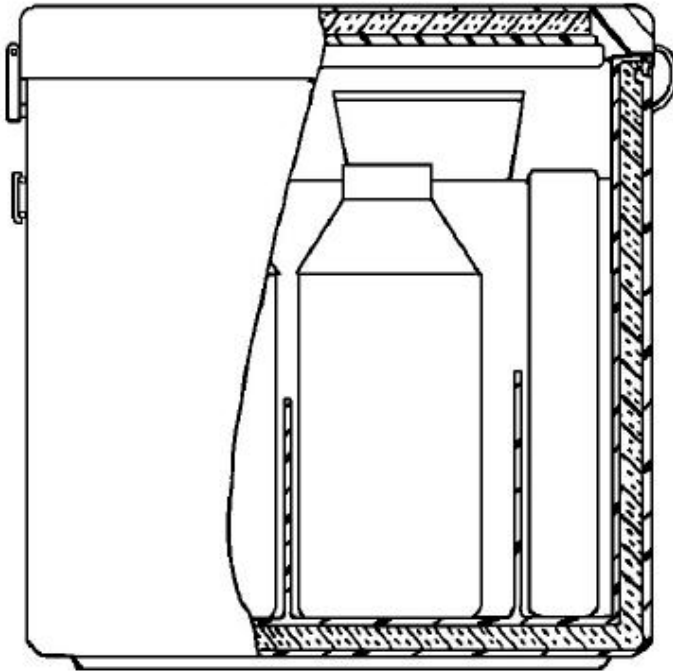
**References*****Informative references***

Attention is drawn to the following places, which may be of interest for search:

Serving trays with means for keeping food cool or hot	A47G 23/0683
Dish-warmers; devices to keep food hot	A47J 39/02

B65D 81/3839

{formed of foam material}

Definition statement

This place covers:

Illustrative example of subject matter classified in this group:

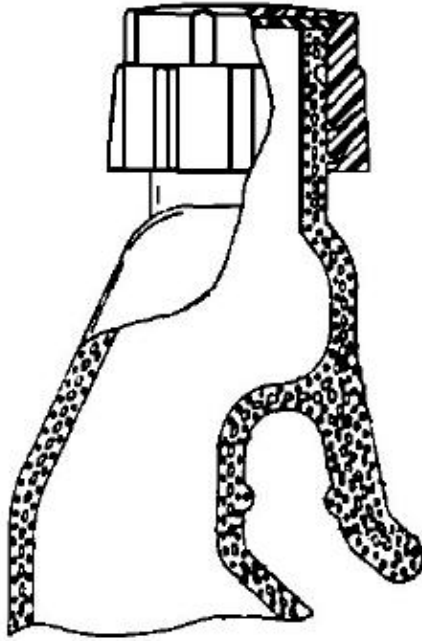

B65D 81/3841

{formed with double walls, i.e. hollow}

Definition statement

This place covers:

Illustrative example of subject matter classified in this group:

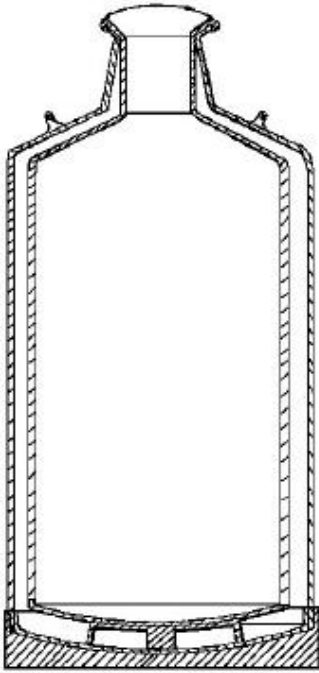

B65D 81/3846

{formed of different materials, e.g. laminated or foam filling between walls}

Definition statement

This place covers:

Illustrative example of subject matter classified in this group:

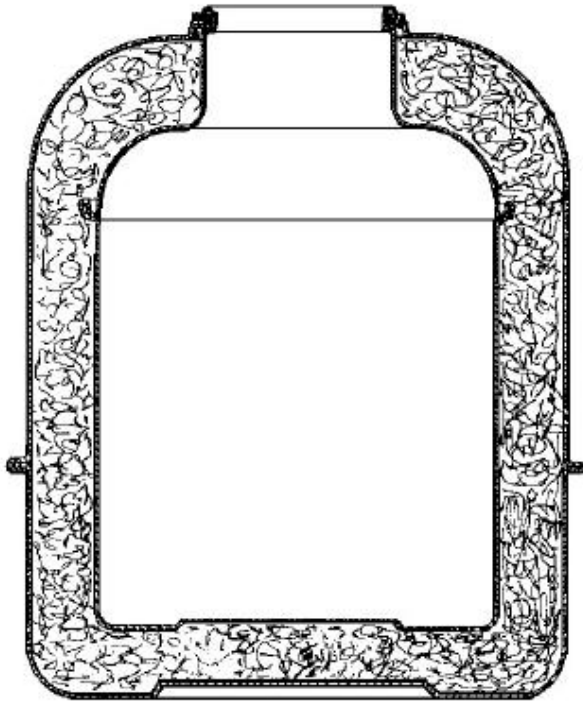

B65D 81/3851

{formed of foam material}

Definition statement

This place covers:

Illustrative example of subject matter classified in this group:

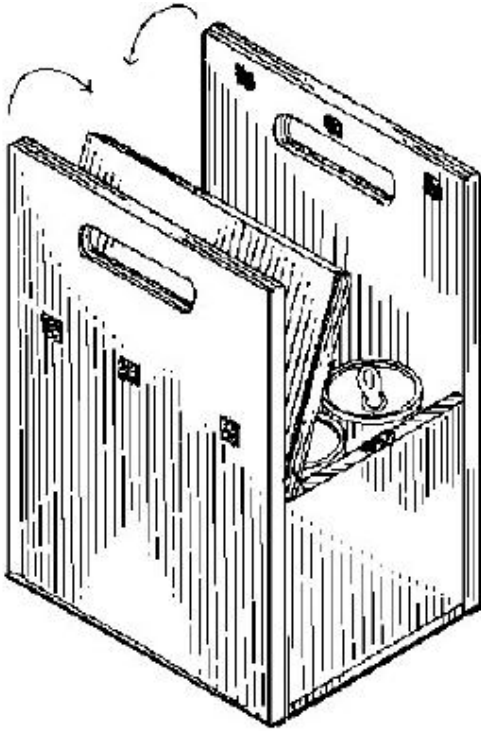

B65D 81/3853**{formed with double walls, i.e. hollow}****Definition statement***This place covers:*

Illustrative example of subject matter classified in this group:

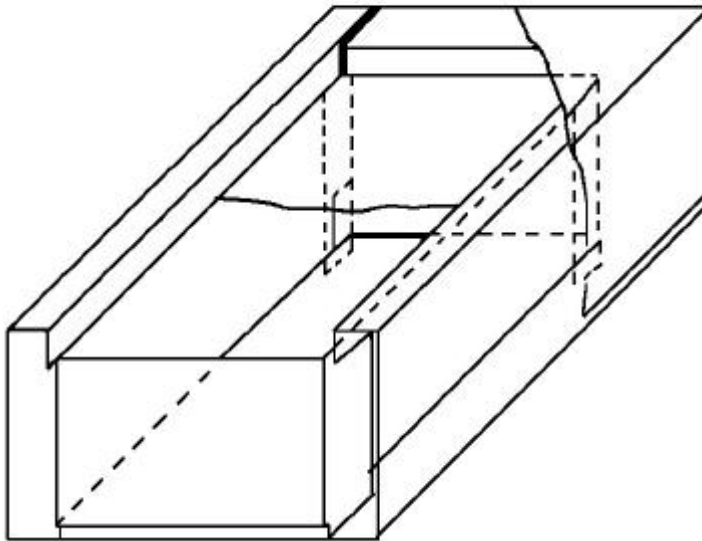
**References****Informative references***Attention is drawn to the following places, which may be of interest for search:*

Linings spaced appreciably from container wall	B65D 5/58
--	---------------------------

B65D 81/3858**{formed of different materials, e.g. laminated or foam filling between walls; (for shock absorbing purposes [B65D 81/1275](#))}****References****Informative references***Attention is drawn to the following places, which may be of interest for search:*

Laminated linings; coatings	B65D 5/563
Linings made of relatively rigid sheet material	B65D 5/566

B65D 81/386**{formed of corrugated material}****Definition statement***This place covers:*

Illustrative example of subject matter classified in this group:

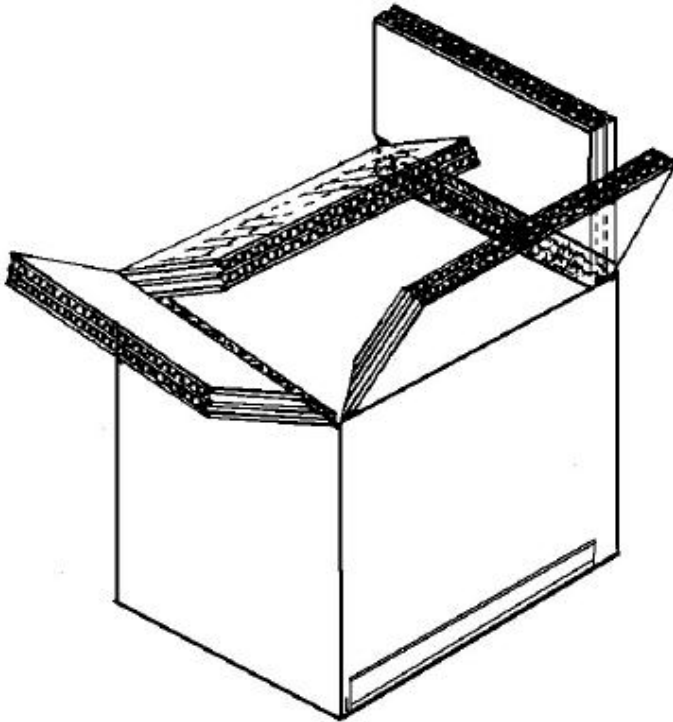
**References*****Informative references****Attention is drawn to the following places, which may be of interest for search:*

Linings made of relatively rigid sheet material	B65D 5/566
---	----------------------------

B65D 81/3862

{with a foam formed container located inside a folded box}

Definition statement

This place covers:

Illustrative example of subject matter classified in this group:

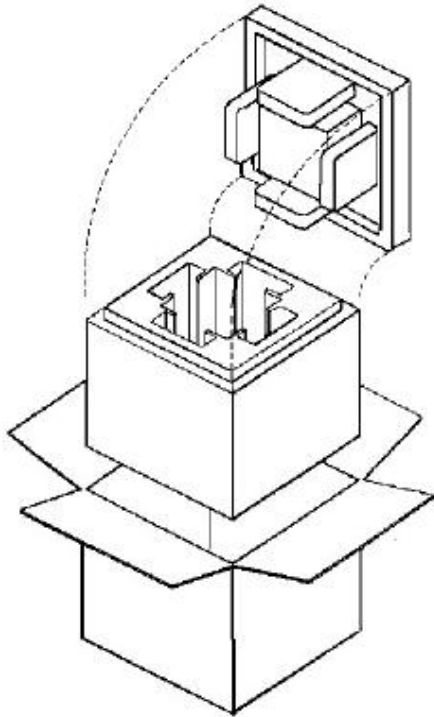

B65D 81/3865

{drinking cups or like containers}

Definition statement

This place covers:

Illustrative example of subject matter classified in this group:

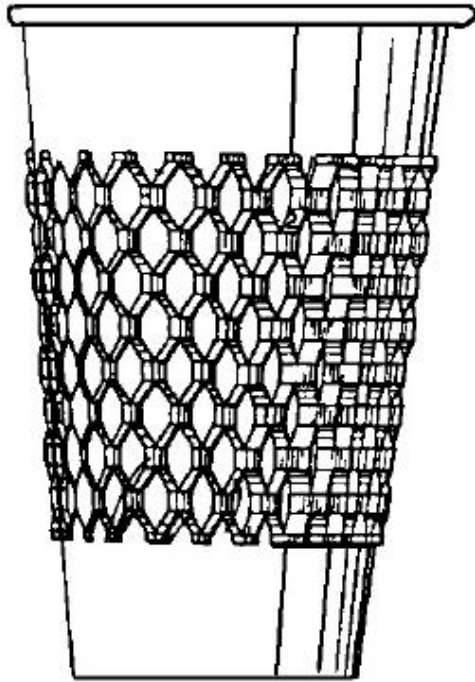

References

Limiting references

This place does not cover:

Insulating sleeves for drinking cups	B65D 81/3876
--------------------------------------	------------------------------

B65D 81/3867

{formed of foam material}

Definition statement

This place covers:

Illustrative example of subject matter classified in this group:

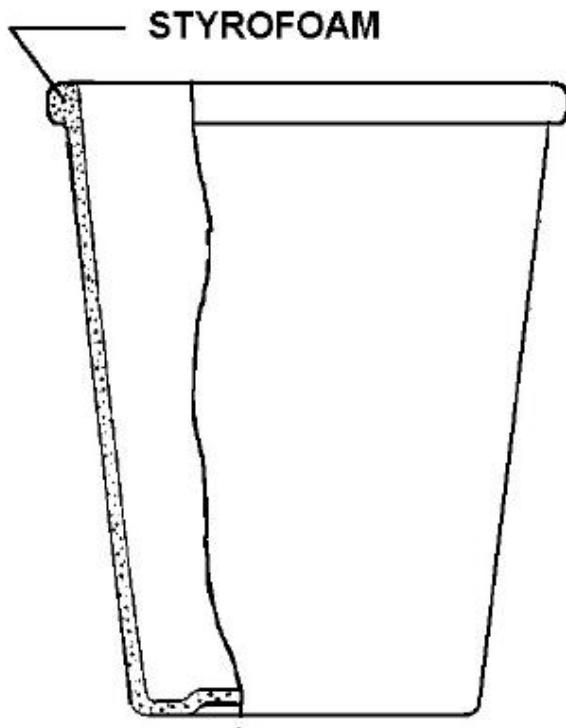

B65D 81/3869

{formed with double walls, i.e. hollow}

Definition statement

This place covers:

Illustrative example of subject matter classified in this group:

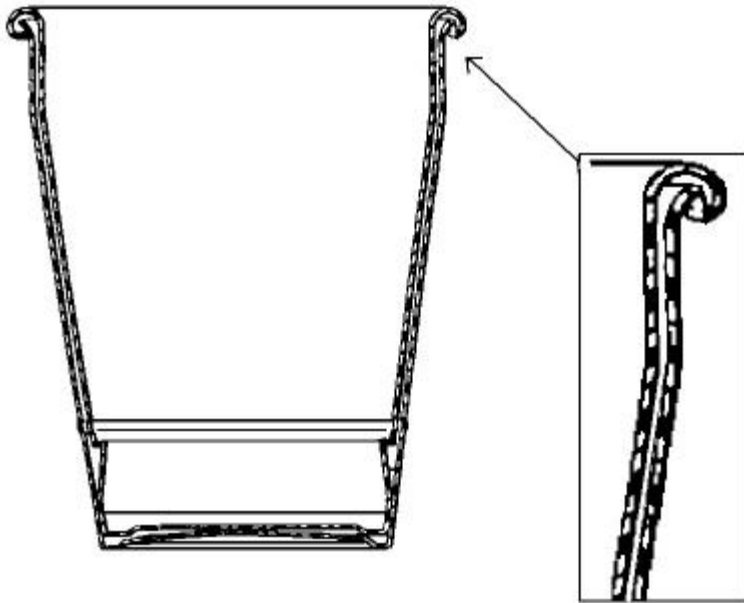

B65D 81/3874

{formed of different materials, e.g. laminated or foam filling between walls}

Definition statement

This place covers:

Illustrative example of subject matter classified in this group:

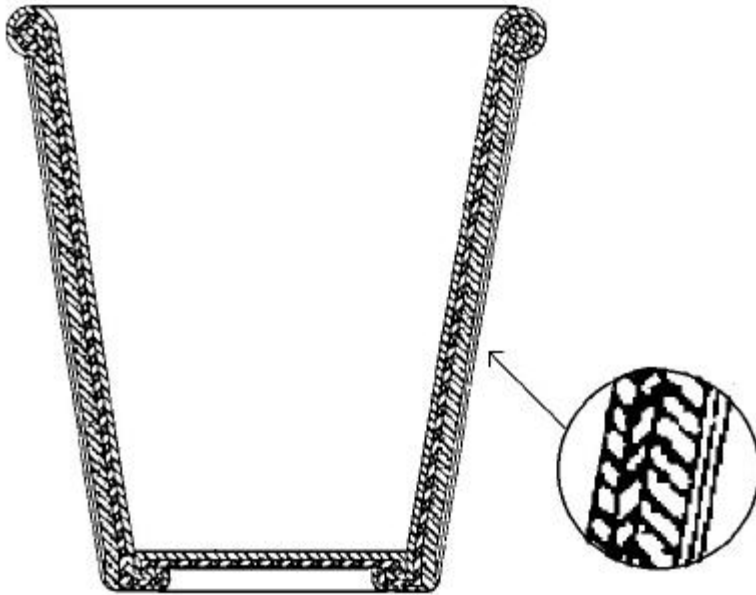

B65D 81/3879

{formed of foam material}

Definition statement

This place covers:

Illustrative example of subject matter classified in this group:

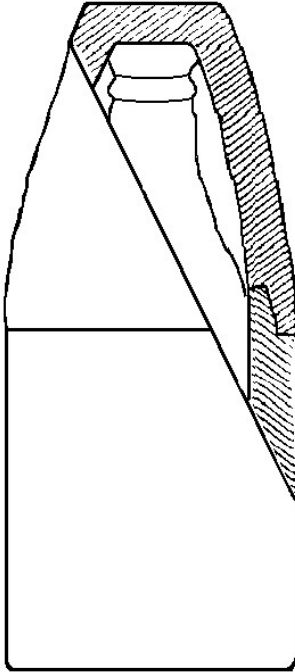

B65D 81/3881

{formed with double walls, i.e. hollow}

Definition statement

This place covers:

Illustrative example of subject matter classified in this group:

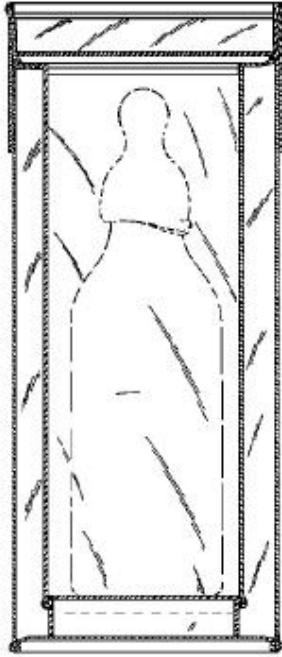

B65D 81/3883

{provided with liquid material between double walls}

Definition statement

This place covers:

Illustrative example of subject matter classified in this group:

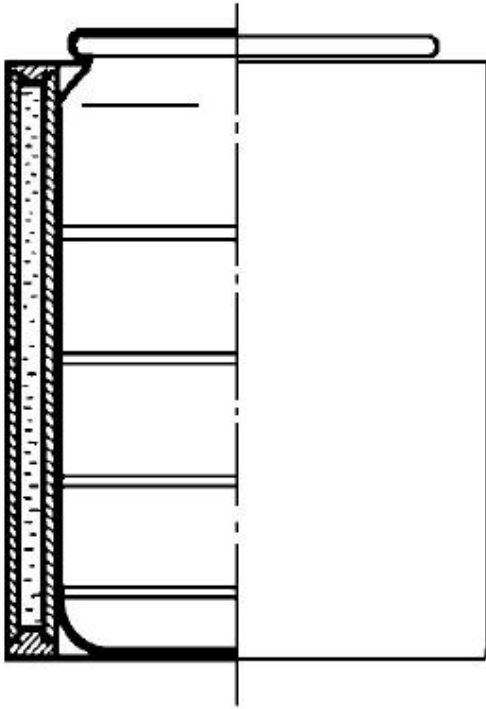

Special rules of classification

ALSO USED AS Indexing Code

B65D 81/3886

{formed of different materials, e.g. laminated or foam filling between walls}

Definition statement

This place covers:

Illustrative example of subject matter classified in this group:

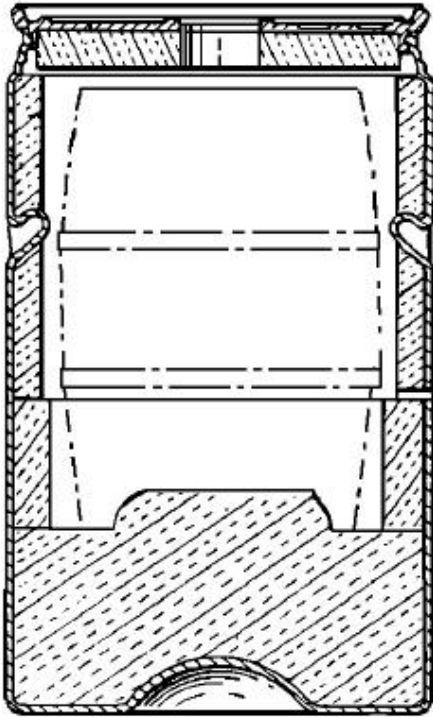

B65D 81/3893

{formed with double walls, i.e. hollow}

Definition statement

This place covers:

Illustrative example of subject matter classified in this group:

—

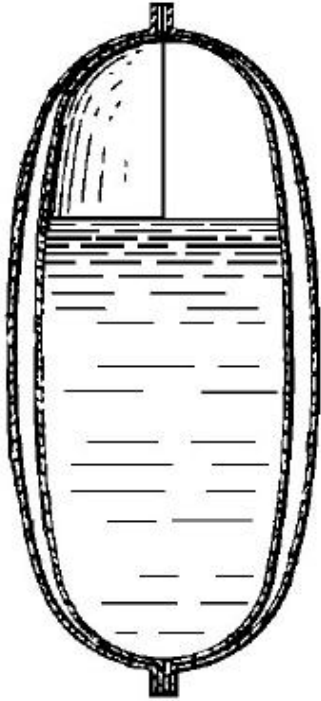

B65D 81/3897

{formed of different materials, e.g. laminated or foam filling between walls}

Definition statement

This place covers:

Illustrative example of subject matter classified in this group:

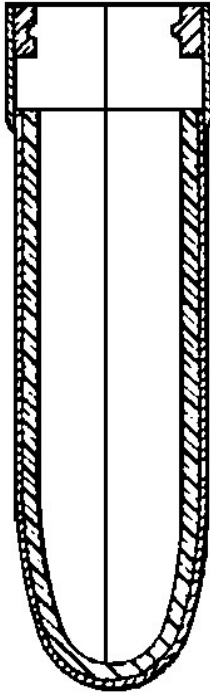
**B65D 83/00**

Containers or packages with special means for dispensing contents (dispensing means incorporated in removable or non-permanently secured container closures [B65D 47/00](#); for shops, stores, offices, bars, or the like [A47F 1/04](#); showcases or show cabinets with dispensing arrangements [A47F 3/02](#); magazines for screws or nuts in combination with spanners, wrenches or screwdrivers [B25B 23/06](#); for use in connection with the handling of sheets, webs, or filamentary material [B65H](#))

References**Limiting references**

This place does not cover:

Dispensing means incorporated in removable or non-permanently secured container closures	B65D 47/00
Containers with arrangements for dispensing articles for shops, stores, offices, bars, or the like	A47F 1/04
Dispensers for nested articles from the top	A47F 1/065
Dispensers for nested articles from the bottom	A47F 1/085

Limiting references

Showcases or show cabinets with dispensing arrangements	A47F 3/02
Magazines for screws or nuts in combination with spanners, wrenches or screwdrivers	B25B 23/06
For use in connection with the handling of sheets, webs, or filamentary material	B65H

Application-oriented references

Examples of places where the subject matter of this place is covered when specially adapted, used for a particular purpose, or incorporated in a larger system:

Packages or dispensers for surgical gloves	A61B 42/40
Containers specially adapted for packaging, protecting, dispensing, collecting or disposing surgical articles	A61B 50/30
Packages or dispensers for prostheses	A61F 2/0095
Packages or dispensers for intraocular lenses	A61F 2/1691
Dispensing containers for dressings or bandages	A61F 15/00
Nail dispensers	B25C 3/00
Ink cartridges	B41J 2/17503

Informative references

Attention is drawn to the following places, which may be of interest for search:

Containers having means for evaporating the content, e.g. deodorant, insecticide	A61L 9/12
coin deliverers	G07D 1/00
coin-freed apparatus for dispensing discrete articles	G07F 11/00

Special rules of classification

The use of available Indexing Codes is mandatory.

B65D 83/0005

{Containers or packages provided with a piston or with a movable bottom or partition having approximately the same section as the container
([B65D 83/0072](#) takes precedence)}

Definition statement

This place covers:

Illustrative example of subject matter classified in this group.

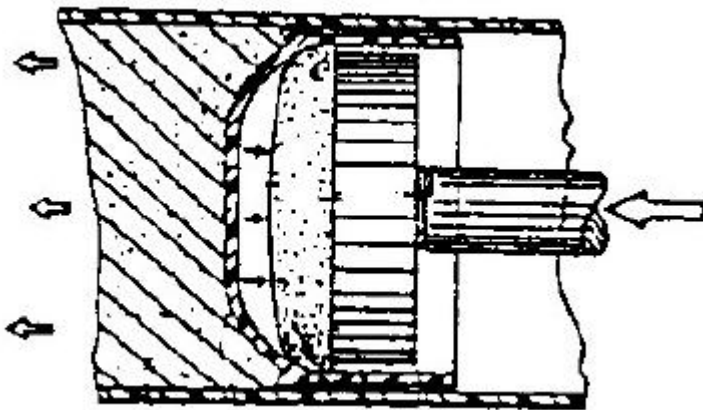
**References****Limiting references**

This place does not cover:

Pistons for pliable tubular containers	B65D 35/30
Floating covers	B65D 81/245
The contents of a flexible bag being expelled by a piston or a movable bottom or partition provided in the container or the package	B65D 83/0072
Containers comprising an internal rotating wing for expelling the contents	B65D 83/0083
Hand tools for discharging fluent material through an outlet orifice by pressure	B05C 17/005

Informative references

Attention is drawn to the following places, which may be of interest for search:

Spraying apparatus for discharge of liquids or other fluent material, without essentially mixing with gas or vapour, supply being effected by follower in container	B05B 9/0838
---	-----------------------------

Special rules of classification

The use of available Indexing Codes is mandatory.

B65D 83/0011

{moved by a screw-shaft}

Definition statement

This place covers:

Illustrative example of subject matter classified in this group.

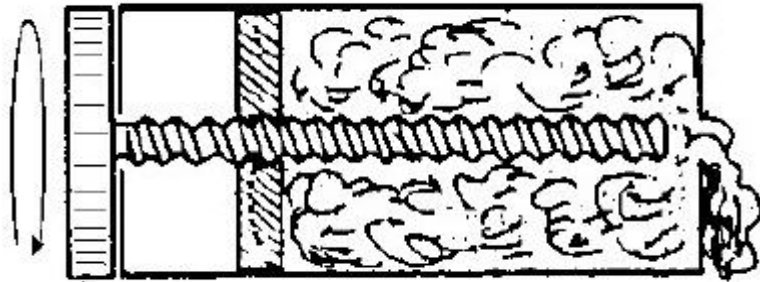

B65D 83/0016

{the contents being forced out through the screw-shaft}

Definition statement

This place covers:

Illustrative example of subject matter classified in this group.

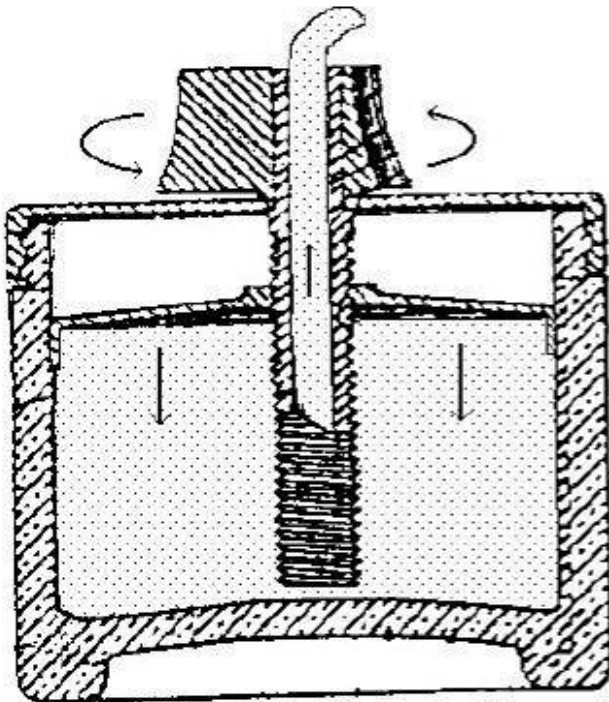

References

Informative references

Attention is drawn to the following places, which may be of interest for search:

Spraying apparatus for discharge of liquids or other fluent material, without essentially mixing with gas or vapour, supply being effected by follower in container	B05B 9/0838
---	-----------------------------

B65D 83/0022

{moved by a reciprocable plunger}

Definition statement

This place covers:

Illustrative example of subject matter classified in this group.

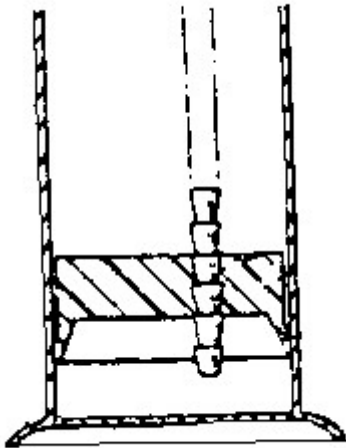

References

Informative references

Attention is drawn to the following places, which may be of interest for search:

Spraying apparatus for discharge of liquids or other fluent material, without essentially mixing with gas or vapour, supply being effected by follower in container	B05B 9/0838
---	-----------------------------

B65D 83/0027**{piston co-operating with a screw-thread in the side wall of the container}****Definition statement**

This place covers:

Illustrative example of subject matter classified in this group.

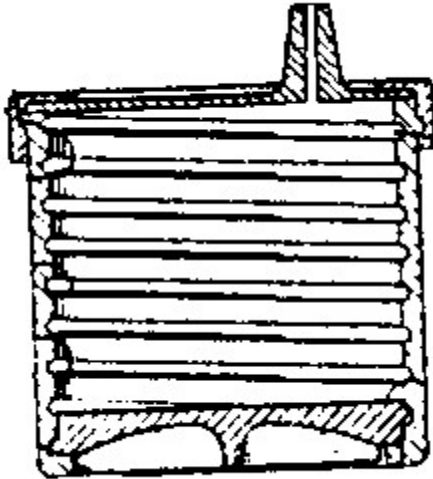
**References*****Informative references***

Attention is drawn to the following places, which may be of interest for search:

Spraying apparatus for discharge of liquids or other fluent material, without essentially mixing with gas or vapour supply being effected by follower in container	B05B 9/047
--	----------------------------

B65D 83/0033

{the piston being a follower-piston and the dispensing means comprising a hand-operated pressure-device at the opposite part of the container}

Definition statement

This place covers:

Illustrative example of subject matter classified in this group.

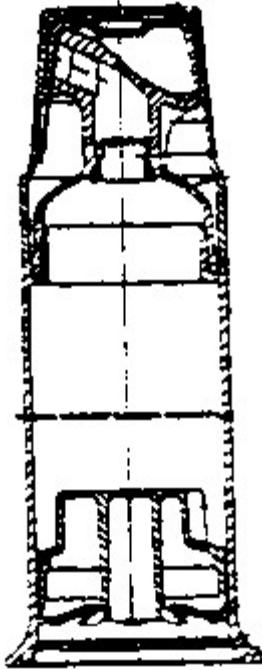
**References****Limiting references**

This place does not cover:

Twin-valves, i.e. hand-operated pumps with a suction AND a discharge valve for dispensing or spraying liquids or other fluent material, e.g. paste	B05B 11/00
Other pumps for dispensing liquids, e.g. air pumps	B67D

Informative references

Attention is drawn to the following places, which may be of interest for search:

Spraying apparatus for discharge of liquids or other fluent material, without essentially mixing with gas or vapour supply being effected by follower in container	B05B 9/047
--	----------------------------

B65D 83/0038

{moved by a spring-like mechanism ([B65D 83/005](#), [B65D 83/0817](#), [B65D 83/0858](#) take precedence)}

Definition statement

This place covers:

Illustrative example of subject matter classified in this group.

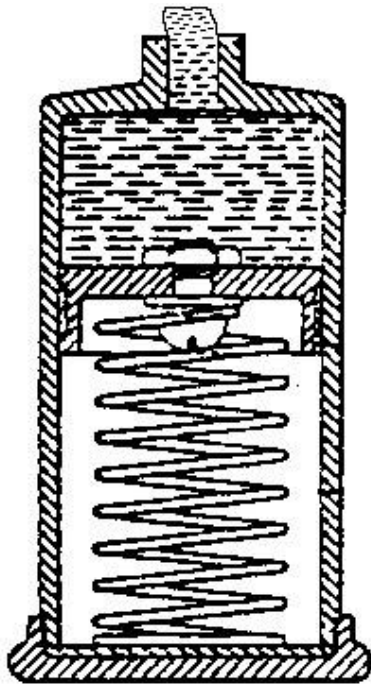
**References****Limiting references**

This place does not cover:

Containers or packages provided with a piston or with a movable bottom or partition having approximately the same section as the container the piston or movable bottom being pulled upwards to dispense the contents	B65D 83/005
Dispensing thin flat articles in succession through an aperture in a wall, the articles being automatically urged towards the dispensing aperture	B65D 83/0817
Dispensing thin flat articles in succession through an aperture at the junction of two walls, the articles being automatically urged towards the dispensing aperture	B65D 83/0858

Informative references

Attention is drawn to the following places, which may be of interest for search:

Moves by a spring-like mechanism	B65D 83/0077
----------------------------------	------------------------------

Spraying apparatus for discharge of liquids or other fluent material, without essentially mixing with gas or vapour supply being effected by follower in container	B05B 9/047
--	----------------------------

B65D 83/0044

{the piston having a dispensing opening formed in the piston ([B65D 83/0016](#) takes precedence)}

Definition statement

This place covers:

Illustrative example of subject matter classified in this group.

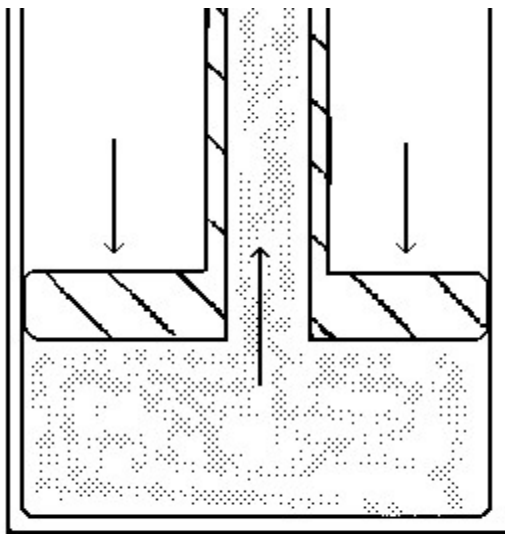

References

Informative references

Attention is drawn to the following places, which may be of interest for search:

The contents being forced out through the screw-shaft	B65D 83/0016
Spraying apparatus for discharge of liquids or other fluent material, without essentially mixing with gas or vapour supply being effected by follower in container	B05B 9/047

B65D 83/005

{the piston or movable bottom being pulled upwards to dispense the contents}

Definition statement

This place covers:

Illustrative example of subject matter classified in this group.

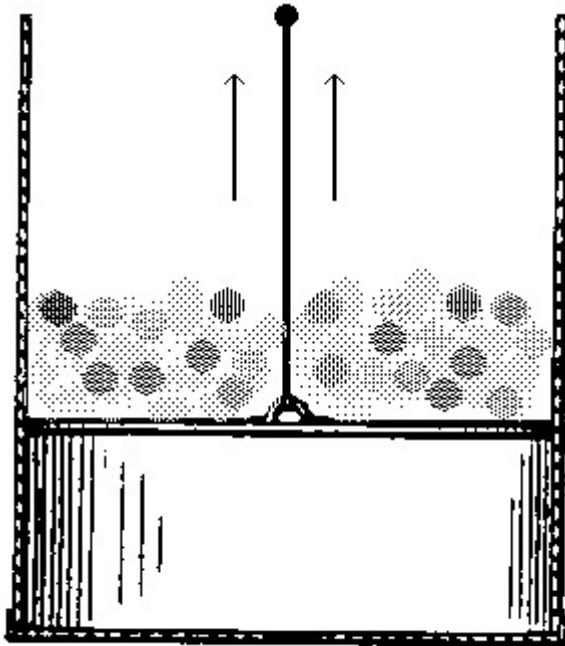
**References****Informative references**

Attention is drawn to the following places, which may be of interest for search:

Hand implements for separating solids from liquids or liquids from liquids	A47J 43/284
Spraying apparatus for discharge of liquids or other fluent material, without essentially mixing with gas or vapour supply being effected by follower in container	B05B 9/047

B65D 83/0055

{Containers or packages provided with a flexible bag or a deformable membrane or diaphragm for expelling the contents}

Definition statement

This place covers:

Illustrative example of subject matter classified in this group.

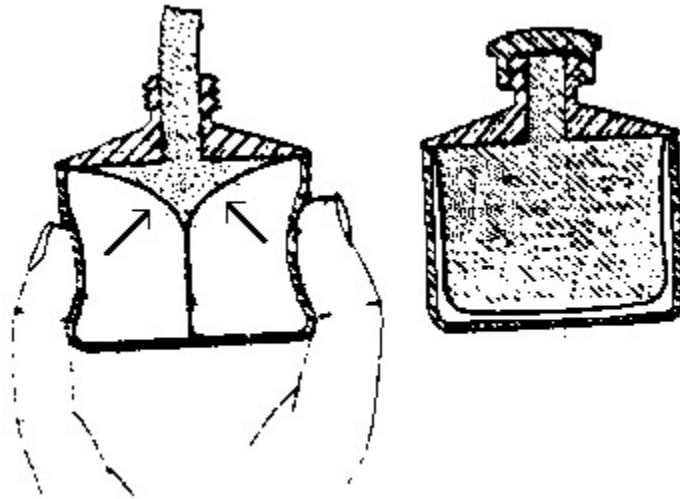
**References****Limiting references**

This place does not cover:

The contents of a flexible bag being expelled by a piston or a movable bottom or partition provided in the container or the package	B65D 83/0072
---	------------------------------

Informative references

Attention is drawn to the following places, which may be of interest for search:

Apparatus utilising compressed air or other gas acting directly or indirectly on beverages in storage containers using elastic bags and pistons actuated by air or other gas	B67D 1/045
--	----------------------------

Special rules of classification

The use of available Indexing Codes is mandatory.

B65D 83/0061

{the contents of a flexible bag being expelled by the contracting forces inherent in the bag or a sleeve fitting snugly around the bag}

Definition statement

This place covers:

Illustrative example of subject matter classified in this group.

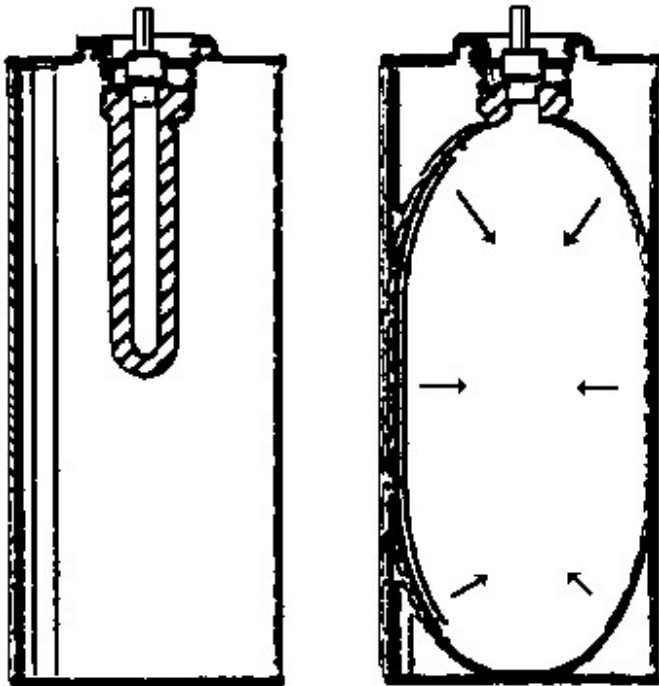
**References****Limiting references**

This place does not cover:

Reservoirs for pressure infusion pressurised by contraction of elastic reservoirs	A61M 5/152
---	----------------------------

Special rules of classification

The use of available Indexing Codes is mandatory.

B65D 83/0066

{the contents of a flexible bag being expelled by twisting the bag}

Definition statement

This place covers:

Illustrative example of subject matter classified in this group.

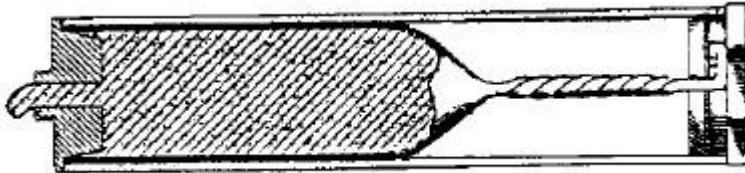

B65D 83/0072

{the contents of a flexible bag being expelled by a piston or a movable bottom or partition provided in the container or the package}

Definition statement

This place covers:

Illustrative example of subject matter classified in this group.

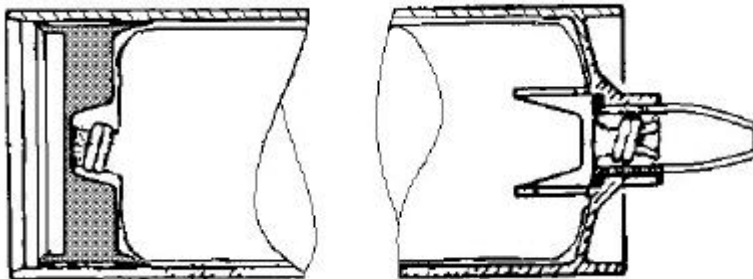

B65D 83/0077**{moves by a spring-like mechanism}****Definition statement***This place covers:*

Illustrative example of subject matter classified in this group.

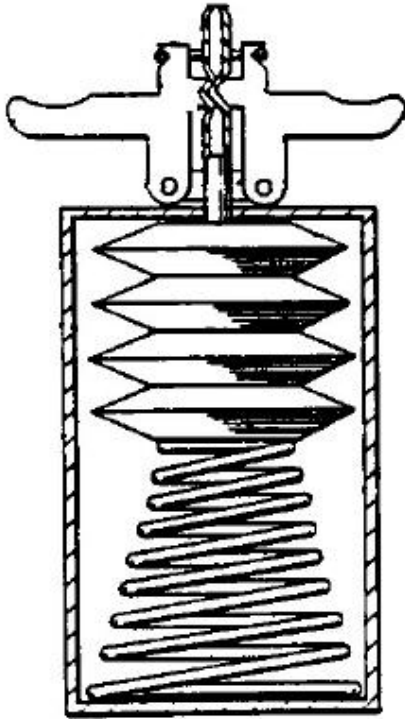
**References*****Informative references****Attention is drawn to the following places, which may be of interest for search:*

Moved by a spring-like mechanism	B65D 83/0038
----------------------------------	------------------------------

B65D 83/0083

{Containers comprising an internal rotating wing for expelling the contents}

Definition statement

This place covers:

Illustrative example of subject matter classified in this group.

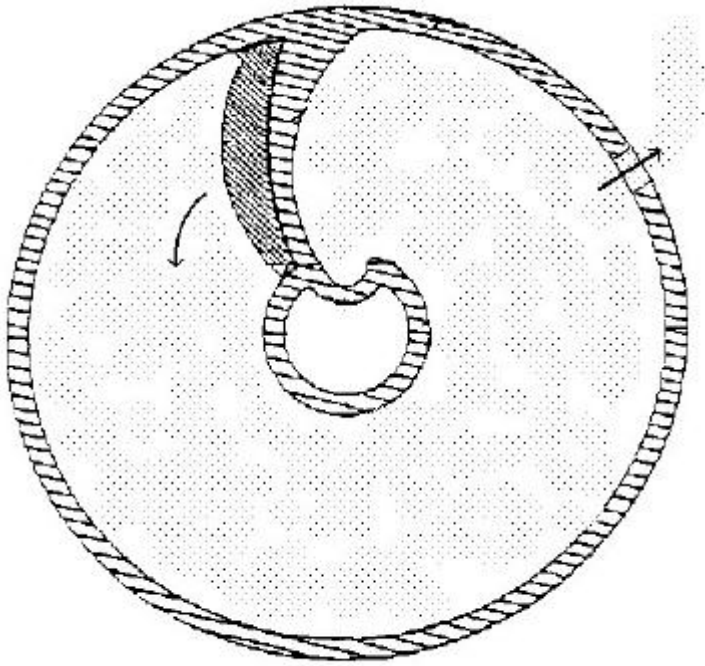

B65D 83/0088

{Packages containing several articles intended to be suspended from a display rod, e.g. blisters, i.e. the package being used to facilitate suspending the articles from the rod}

Definition statement

This place covers:

Illustrative example of subject matter classified in this group.

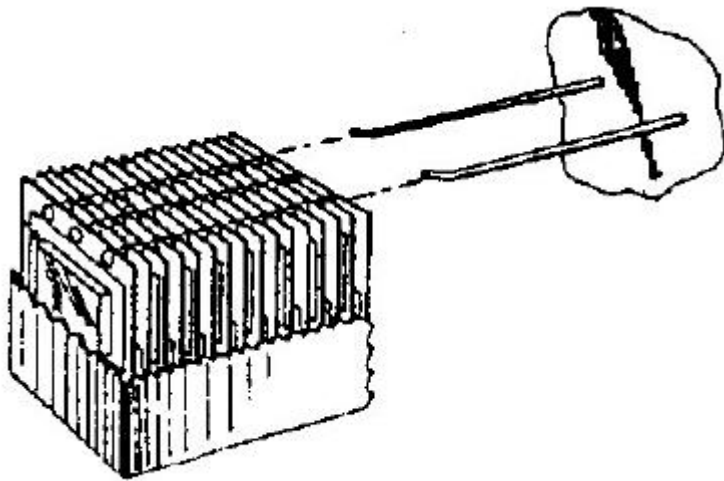

B65D 83/0094

{Containers having an external wall formed as, or with, a diaphragm or the like which is deformed to expel the contents ([B65D 1/32](#) takes precedence)}

Definition statement

This place covers:

Illustrative example of subject matter classified in this group.

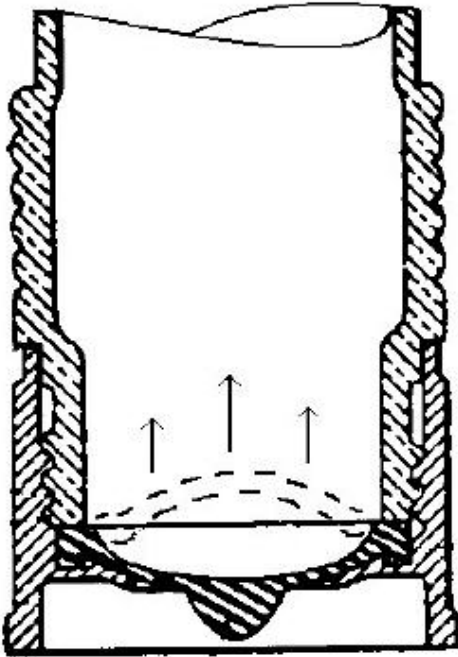
**References****Limiting references**

This place does not cover:

Containers adapted to be temporarily deformed by external pressure to expel contents; containers for pharmaceutical purposes; containers with disinfecting linings; liquid sprayers; Kaufman type dispensers based on the siphon principle; oil cans	B65D 1/32
--	---------------------------

B65D 83/02

for dispensing rod-shaped articles, e.g. needles {(packages for cigarettes provided with dispensing means [B65D 85/1009](#); dispensers for drinking straws [A47G 21/184](#)}

Definition statement

This place covers:

Illustrative example of subject matter classified in this group.

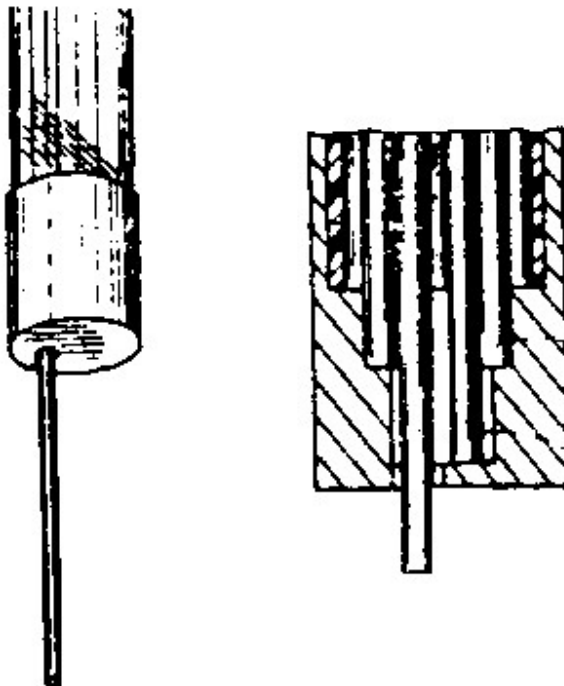
**References****Limiting references**

This place does not cover:

Packages for cigarettes provided with dispensing means	B65D 85/1009
Dispensers for drinking straws	A47G 21/184

Application-oriented references

Examples of places where the subject matter of this place is covered when specially adapted, used for a particular purpose, or incorporated in a larger system:

Cotton-swabs per se	A45D , A61F 11/00 , B65D 13/00 , A61M 35/00
Tooth-pick holders	A47G 21/12
Tooth-picks	A61C 15/02
Dispensers for bandages, swab sticks	A61F 15/001
Dispensers for catamenial tampons	A61F 15/003

Distributors for pencil leads, cartridges and the like	B43K 31/005
--	-----------------------------

Informative references

Attention is drawn to the following places, which may be of interest for search:

Containers, packaging elements or packages specially adapted for needles, nails, or other like elongated small articles	B65D 85/24
cigar or cigarette receptacles or boxes	A24F 15/00

B65D 83/04

for dispensing annular, disc-shaped, or spherical or like small articles, e.g. tablets or pills

References

Limiting references

This place does not cover:

For dispensing tickets or tokens	B65D 83/12
Racks for dispensing granulated or powdered materials	A47F 1/02
Medicament distribution means	A61J 7/00
Devices for breaking pills	A61J 7/0007
Arrangement for time indication or reminder for taking medicine	A61J 7/04
Coin & token deliverers	G07D 1/00
Cases for button cells	H01M 50/216
Cases for miniature batteries	H01M 50/247

Informative references

Attention is drawn to the following places, which may be of interest for search:

For dispensing powdered or granular material	B65D 83/06
--	----------------------------

Special rules of classification

The use of available Indexing Codes is mandatory.

B65D 83/0409

{the dispensing means being adapted for delivering one article, or a single dose, upon each actuation ([B65D 83/0445](#) takes precedence)}

References

Limiting references

This place does not cover:

All the articles being stored in individual compartments	B65D 83/0445
--	------------------------------

The dispensing means forming a part of a removable closure, e.g. gripping teeth, cavity	B65D 83/049
---	-----------------------------

Informative references

Attention is drawn to the following places, which may be of interest for search:

For dispensing powdered or granular material	B65D 83/06
--	----------------------------

Special rules of classification

The use of available Indexing Codes is mandatory.

B65D 83/0418

{the articles being substantially flat and stacked one upon the other and the dispensing-closing device sliding the article to be dispensed along the flat side of the next article}

Definition statement

This place covers:

Illustrative example of subject matter classified in this group.

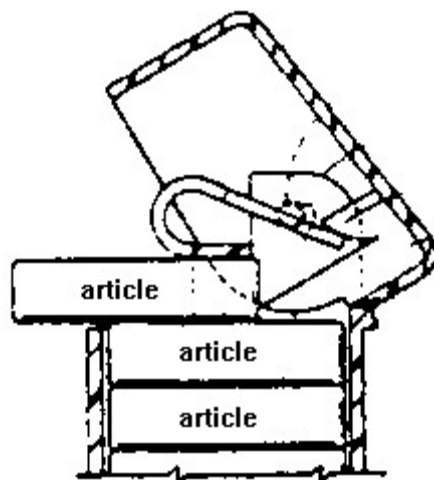

References

Informative references

Attention is drawn to the following places, which may be of interest for search:

For dispensing powdered or granular material	B65D 83/06
--	----------------------------

Special rules of classification

The use of available Indexing Codes is mandatory.

B65D 83/0427

{the articles being dispensed by inverting the container each time, by which action movable parts may be displaced by their own weight}

Definition statement

This place covers:

Illustrative example of subject matter classified in this group.

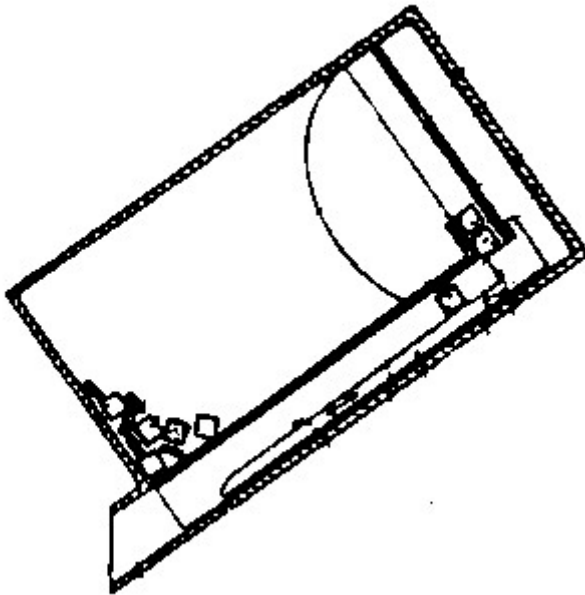

References

Informative references

Attention is drawn to the following places, which may be of interest for search:

For dispensing powdered or granular material	B65D 83/06
--	----------------------------

Special rules of classification

The use of available Indexing Codes is mandatory.

B65D 83/0436

{the articles being dispensed by pinching action on a flexible tube}

Definition statement

This place covers:

Illustrative example of subject matter classified in this group.

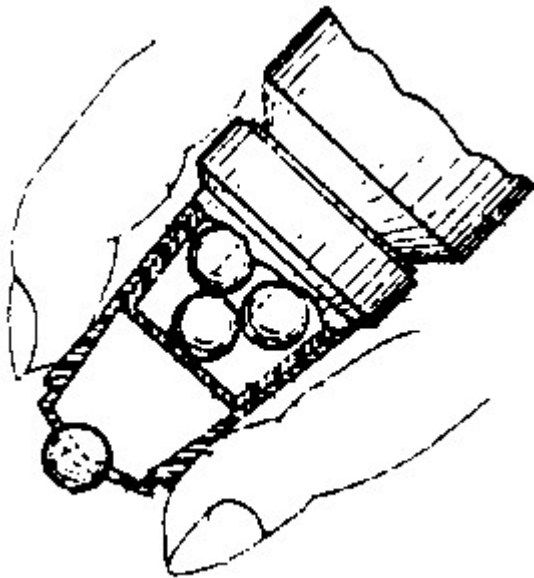
**References****Limiting references**

This place does not cover:

Pinching action without retaining the following articles comprising hand-operated members for controlling discharge	B65D 83/0481
---	------------------------------

Informative references

Attention is drawn to the following places, which may be of interest for search:

Closures with discharging devices other than pumps	B65D 47/20
For dispensing powdered or granular material	B65D 83/06

Special rules of classification

The use of available Indexing Codes is mandatory.

B65D 83/0445

{all the articles being stored in individual compartments}

References**Limiting references**

This place does not cover:

Compartmented boxes, the compartments of which have to be filled for each period	A61J 1/03
--	---------------------------

Special rules of classification

The use of available Indexing Codes is mandatory.

B65D 83/0454

{the whole forming a circular container with rotating parts ([B65D 83/0463](#) takes precedence)}

Definition statement

This place covers:

Illustrative example of subject matter classified in this group.

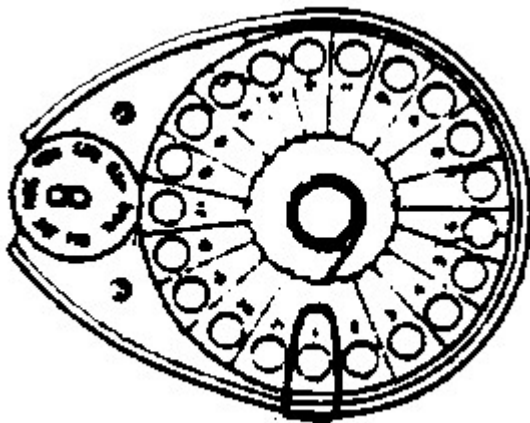
**References****Limiting references**

This place does not cover:

Formed in a band or a blisterweb, inserted in a dispensing device or container	B65D 83/0463
Compartmented boxes, the compartments of which have to be filled for each period	A61J 1/03

Special rules of classification

The use of available Indexing Codes is mandatory.

B65D 83/0463

{formed in a band or a blisterweb, inserted in a dispensing device or container}

Definition statement

This place covers:

Illustrative example of subject matter classified in this group.

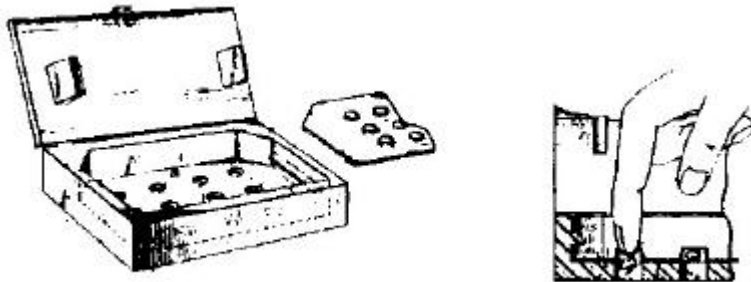
**References****Informative references**

Attention is drawn to the following places, which may be of interest for search:

Unpacking of articles or materials, not otherwise provided for, by expelling solid contents	B65B 69/0058
---	------------------------------

Special rules of classification

The use of available Indexing Codes is mandatory.

B65D 83/0472

{the band being wound in flat spiral, folded in accordion or the like}

Definition statement

This place covers:

Illustrative example of subject matter classified in this group.

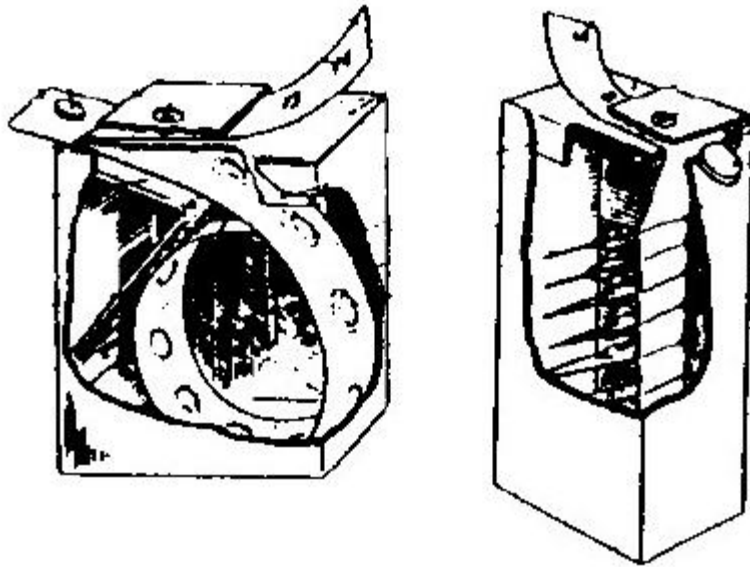

Special rules of classification

The use of available Indexing Codes is mandatory.

B65D 83/0481

{the articles passing through a small opening or passage, without additional dispensing devices and without retaining means for the following article}

Definition statement

This place covers:

Illustrative examples of subject matter classified in this group.

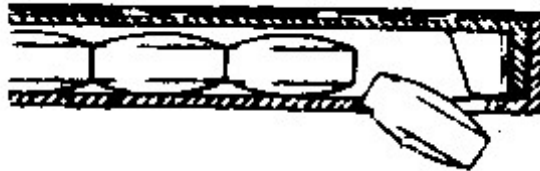
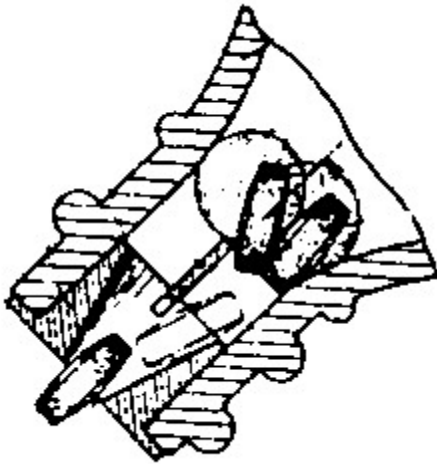

References

Informative references

Attention is drawn to the following places, which may be of interest for search:

The articles being dispensed by pinching action on a flexible tube	B65D 83/0436
--	------------------------------

Special rules of classification

The use of available Indexing Codes is mandatory.

B65D 83/049

{the dispensing means forming a part of a removable closure, e.g. gripping teeth, cavity}

Definition statement

This place covers:

Illustrative example of subject matter classified in this group.

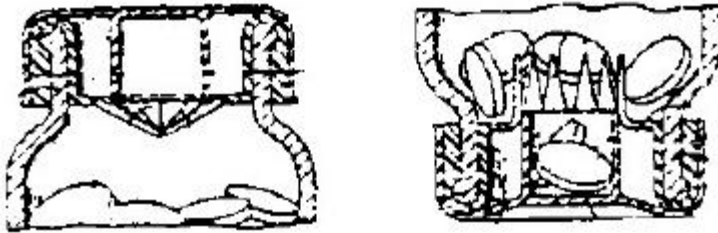

References

Informative references

Attention is drawn to the following places, which may be of interest for search:

For dispensing powdered or granular material	B65D 83/06
--	----------------------------

Special rules of classification

The use of available Indexing Codes is mandatory.

B65D 83/06

for dispensing powdered or granular material {([B65D 83/04](#) takes precedence)}

Definition statement

This place covers:

Illustrative example of subject matter classified in this group.

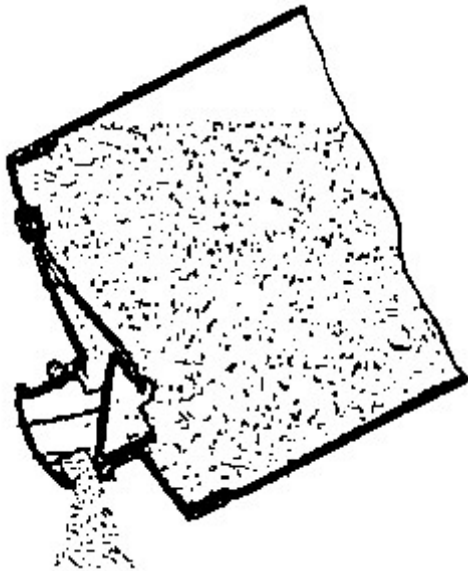
**References****Limiting references**

This place does not cover:

Dispenser for annular, disc-shaped, or spherical or like small articles	B65D 83/04
---	----------------------------

Informative references

Attention is drawn to the following places, which may be of interest for search:

Racks for dispensing granulated or powdered materials	A47F 1/02
spraying or atomising apparatus in general	B05B
Measuring apparatus for volume of fluent solid material	G01F 1/00

B65D 83/08

for dispensing thin flat articles in succession ({towel dispensers intended for re-use [A47K 10/24](#);} dispensers for surgical scalpel blades [A61B 17/3215](#))

References**Limiting references**

This place does not cover:

towel dispensers intended for re-use	A47K 10/24
--------------------------------------	----------------------------

dispensers for surgical scalpel blades	A61B 17/3215
--	------------------------------

Informative references

Attention is drawn to the following places, which may be of interest for search:

Dispenser for annular, disc-shaped, or spherical or like small articles	B65D 83/04
For dispensing razor-blades, tickets or tokens	B65D 83/10 , B65D 83/12
Cigarette paper	A24F 17/00
Dressings or bandages	A61F 15/00
Reusable dispenser for e.g. "post-it"	B42D 5/005

B65D 83/0805

{through an aperture in a wall}

Definition statement

This place covers:

Illustrative example of subject matter classified in this group.

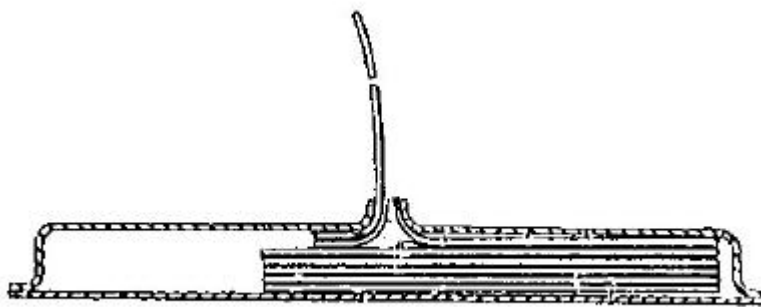

References

Limiting references

This place does not cover:

With provision for used articles	B65D 83/0888
The articles being positioned relative to one another or to the container in a special way, e.g. for facilitating dispensing, without additional support	B65D 83/0894

B65D 83/0817

{the articles being automatically urged towards the dispensing aperture, e.g. spring-loaded ([B65D 83/0823](#) takes precedence)}

Definition statement

This place covers:

Illustrative example of subject matter classified in this group.

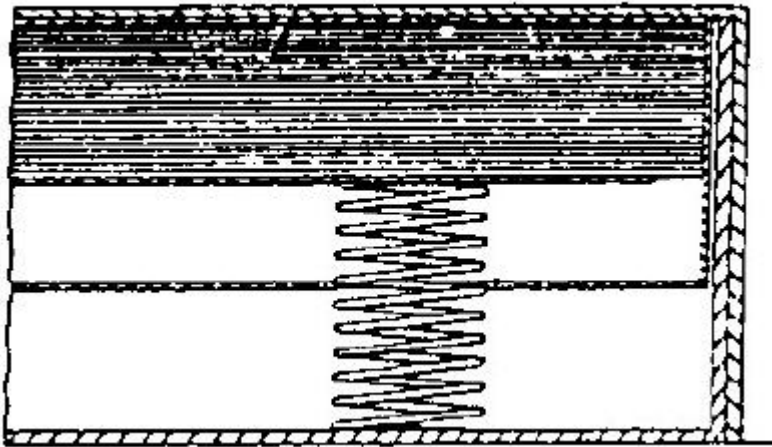
**References****Limiting references**

This place does not cover:

The articles being pushed and slid through the aperture	B65D 83/0823
---	------------------------------

B65D 83/0823

{the articles being pushed and slid through the aperture}

Definition statement

This place covers:

Illustrative example of subject matter classified in this group.

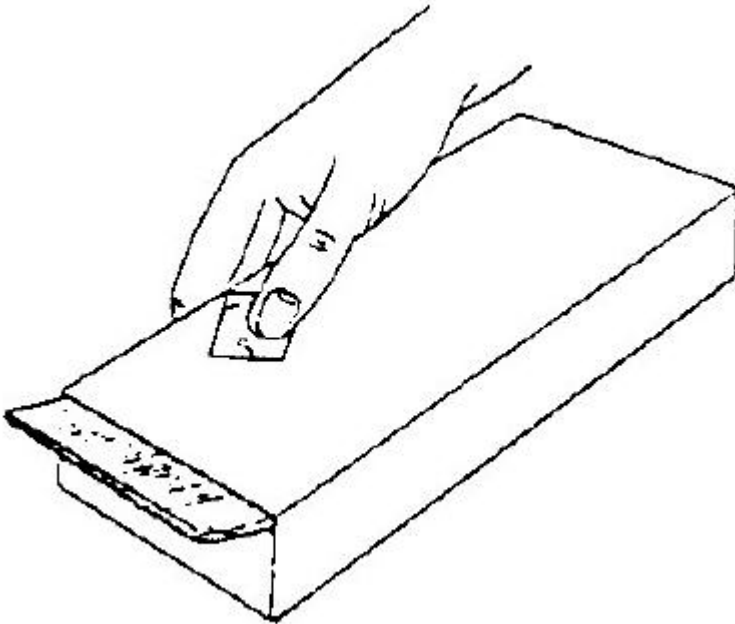

B65D 83/0829

{by means of an actuator}

Definition statement

This place covers:

Illustrative example of subject matter classified in this group.

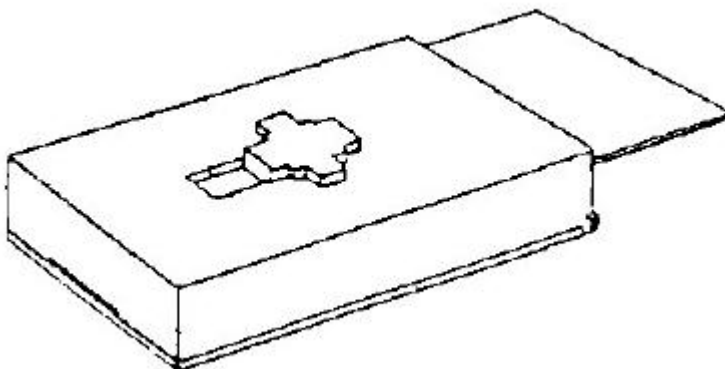

B65D 83/0835

{the articles being pulled out of the container}

Definition statement

This place covers:

Illustrative example of subject matter classified in this group.

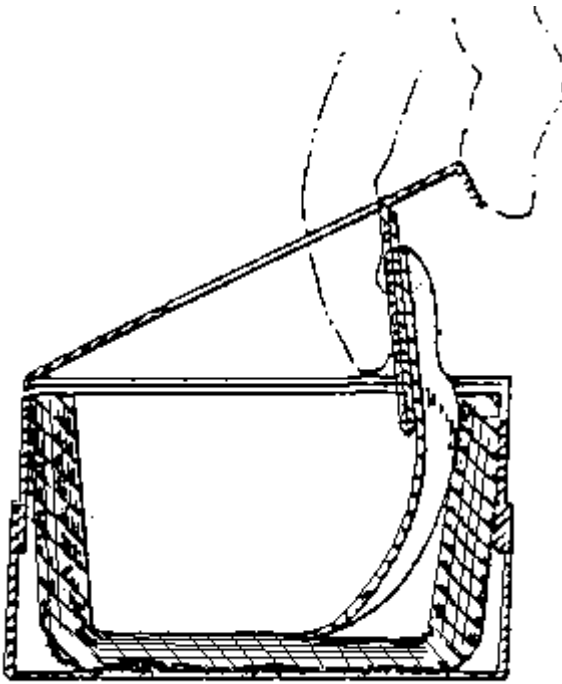

B65D 83/0841

{and for cutting interconnected articles (cutting devices for dispensers intended for re-use [B65H 35/008](#))}

Definition statement

This place covers:

Illustrative example of subject matter classified in this group.

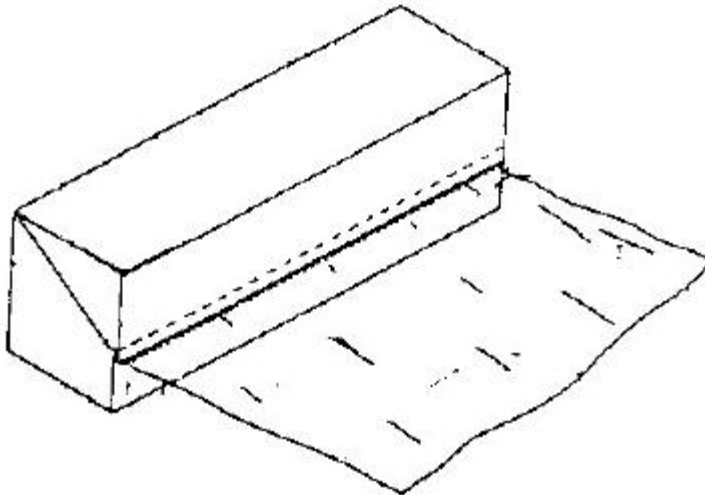

B65D 83/0847**{through an aperture at the junction of two walls}****Definition statement***This place covers:*

Illustrative example of subject matter classified in this group.

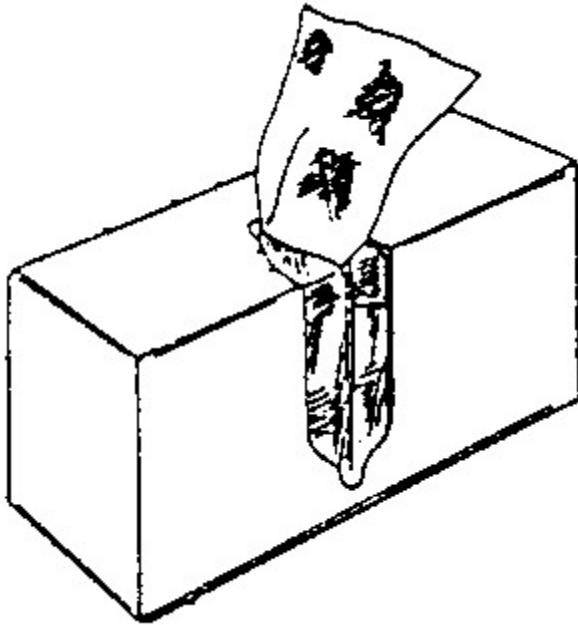
**References****Limiting references***This place does not cover:*

With provision for used articles	B65D 83/0888
The articles being positioned relative to one another or to the container in a special way, e.g. for facilitating dispensing, without additional support	B65D 83/0894

B65D 83/0858

{the articles being automatically urged towards the dispensing aperture, e.g. spring-loaded ([B65D 83/0864](#) takes precedence)}

Definition statement

This place covers:

Illustrative example of subject matter classified in this group.

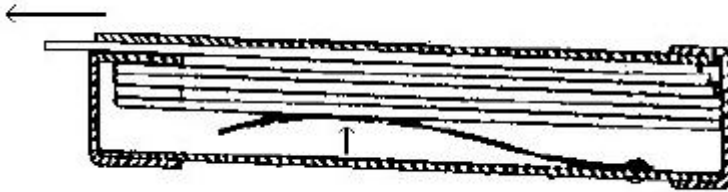
**References****Limiting references**

This place does not cover:

The articles being pushed and slid through the aperture	B65D 83/0864
---	------------------------------

B65D 83/0864

{the articles being pushed and slid through the aperture}

Definition statement

This place covers:

Illustrative example of subject matter classified in this group.

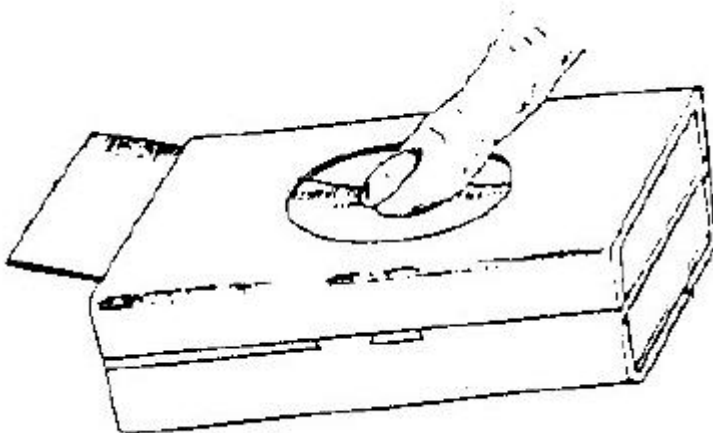

B65D 83/087

{by means of an actuator}

Definition statement

This place covers:

Illustrative example of subject matter classified in this group.

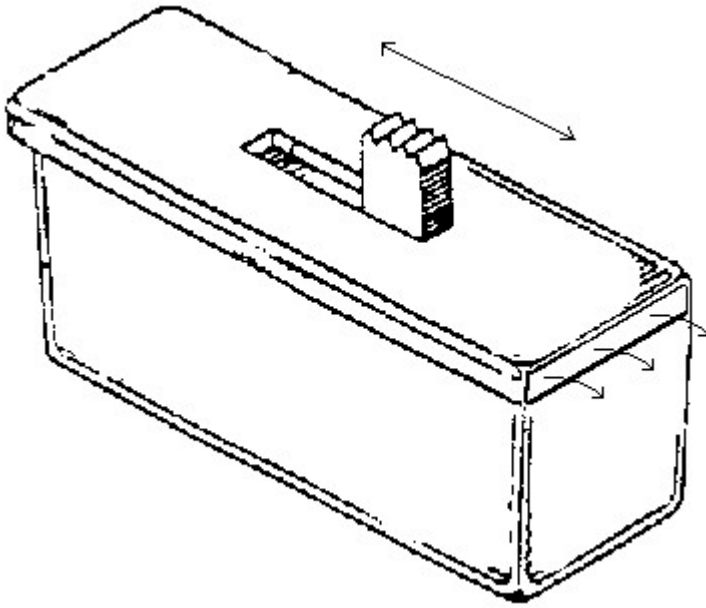

B65D 83/0876

{the articles being pulled out of the container}

Definition statement

This place covers:

Illustrative example of subject matter classified in this group.

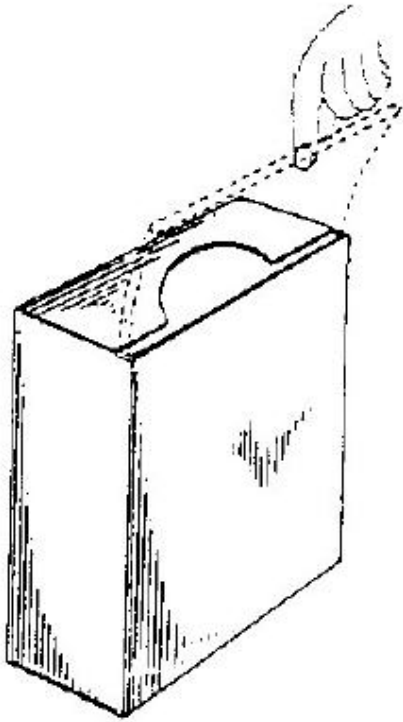

B65D 83/0882

{and for cutting interconnected articles (cutting devices for dispensers intended for re-use [B65H 35/008](#))}

Definition statement

This place covers:

Illustrative example of subject matter classified in this group.

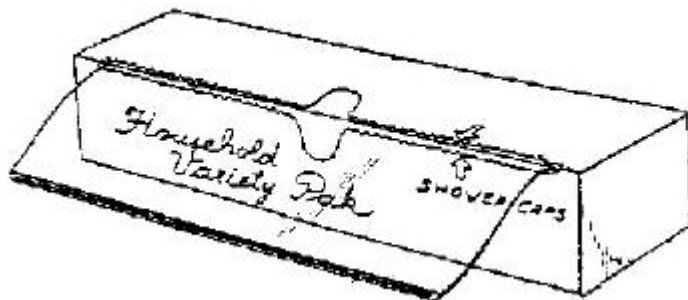

B65D 83/0888

{with provision for used articles}

Definition statement

This place covers:

Illustrative example of subject matter classified in this group.

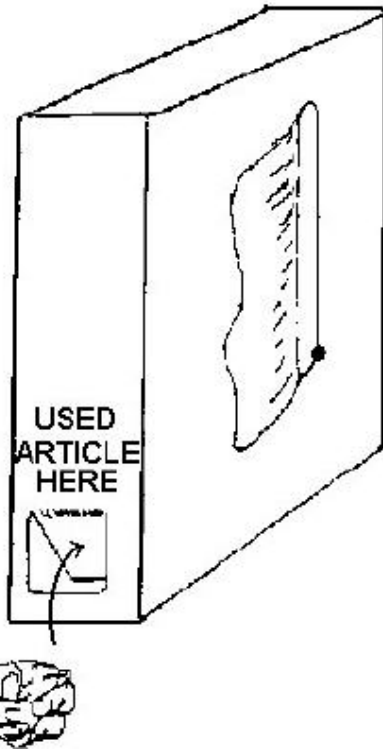

References

Limiting references

This place does not cover:

For other applications	B65D 2209/00
------------------------	------------------------------

B65D 83/0894

{the articles being positioned relative to one another or to the container in a special way, e.g. for facilitating dispensing, without additional support}

Definition statement

This place covers:

Illustrative example of subject matter classified in this group.

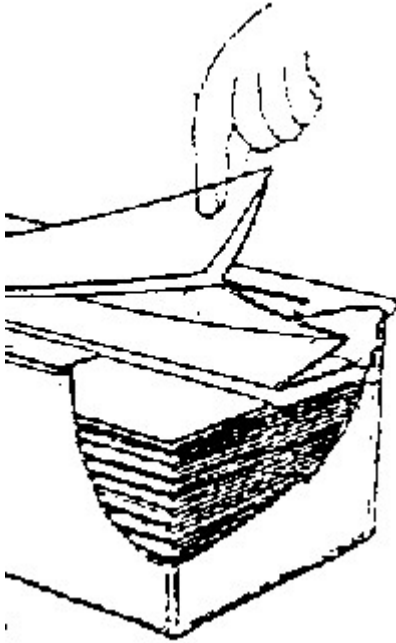

B65D 83/10**for dispensing razor-blades****Definition statement***This place covers:*

Illustrative example of subject matter classified in this group.

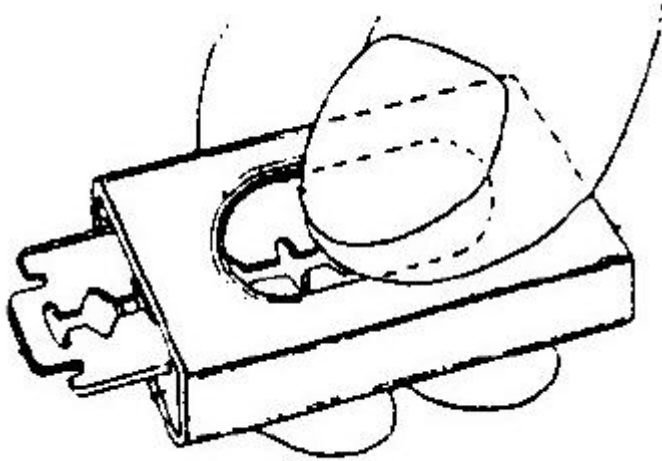
**References****Limiting references***This place does not cover:*

Carriers for storing razor cartridges	A45D 27/24
Razors, safety razors in general	B26B 21/00

B65D 83/12**for dispensing tickets or tokens****Definition statement***This place covers:*

Illustrative example of subject matter classified in this group.

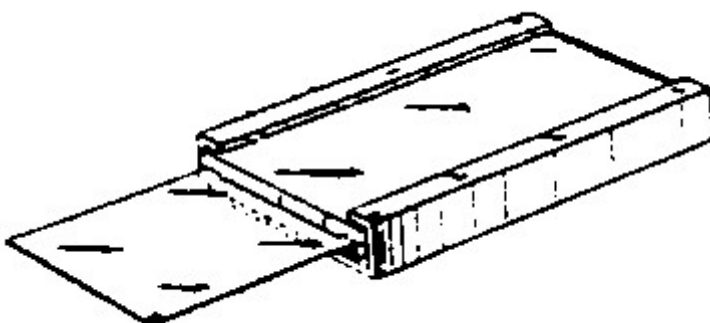

References

Informative references

Attention is drawn to the following places, which may be of interest for search:

Racks for dispensing merchandise; Containers for dispensing merchandise	A47F 1/00
---	---------------------------

B65D 83/14

for delivery of liquid or semi-liquid contents by internal gaseous pressure, i.e. aerosol containers comprising propellant {for a product delivered by a propellant}

References

Informative references

Attention is drawn to the following places, which may be of interest for search:

Spraying devices for the destruction of noxious animals or plants	A01M 7/00
Sprayers for therapeutic purposes	A61M 11/00
Spraying or atomizing apparatus in general	B05B
Removing gases or liquids enclosed in discarded aerosol cans	B09B 3/00 , B09B 2101/02
Aerosol compositions, e.g. propellants	C09K 3/30
Pumping of fluid by direct contact of another fluid, e.g. siphons	F04F
Fluid-delivery valves in general	F16K 21/00
Discharge nozzles in general	F16K 31/58
Vessels for containing or storing compressed, liquefied, or solidified gases	F17C

B65D 83/16

characterised by the actuating means

References

Informative references

Attention is drawn to the following places, which may be of interest for search:

For delivery of liquid or semi-liquid contents by internal gaseous pressure	B65D 83/14
Actuation occurring by moving the aerosol container relative to an outer shell	B65D 83/386
Involved in metering valve assemblies	B65D 83/546
Marking apparatus with wheeled frame, marking material being supplied in aerosol containers	E01C 23/22

B65D 83/22

with {a mechanical} means to disable actuation ([B65D 50/00](#) takes precedence)

Definition statement

This place covers:

Actuator locking means that can be manually put in place again after use to prevent, e.g. unintended, actuation until next use.

The means may completely block the actuator or only restrict its course.

References

Limiting references

This place does not cover:

Closures with means for discouraging unauthorised opening or removal thereof	B65D 50/00
--	----------------------------

Informative references

Attention is drawn to the following places, which may be of interest for search:

Means for preventing delivery	B65D 83/56
Hand-held spraying apparatuses (without any pressure built inside the container) comprising means for locking the pump or its actuation means	B05B 11/1059

Special rules of classification

If an aerosol container comprises both, means for disabling actuation and means for preventing delivery, the document shall be classified in [B65D 83/22](#) and [B65D 83/56](#) even if these means are linked.

Example: US4542837 discloses a dome actuator (10) fitted to an aerosol container (12) wherein rotation of the upper part (14) of the dome actuator raises an actuating member (22) which actuates the dispensing valve when in a fully raised position, i.e. if the upper part (14) is rotated enough. Pressure on the actuating member (22) in a partially raised position will tend to lower it to its flush position with the top panel (24) and thereby will not actuate the dispensing valve. This aspect is classified in [B65D 83/56](#) since delivery is prevented and actuating is not disabled.

The fact that the actuator in the retracted position is immovable, i.e. locked is classified in [B65D 83/22](#).

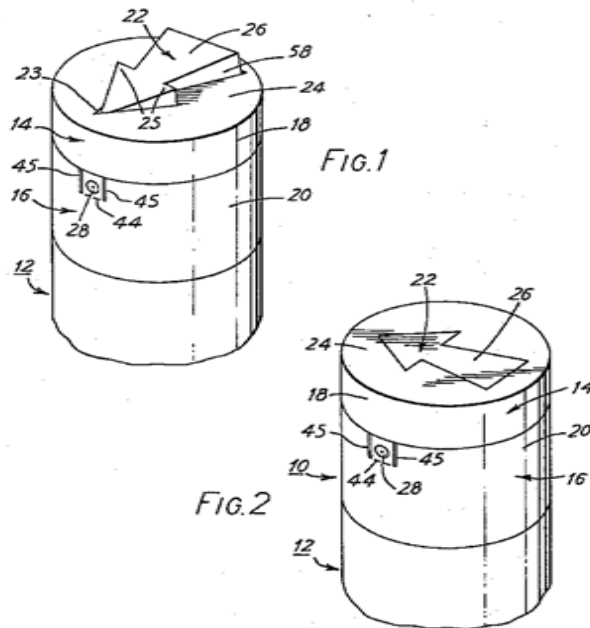

B65D 83/38

Details of the container body (pressure relief devices [B65D 83/70](#))

Definition statement

This place covers:

E.g. outer decorative housing.

E.g. all plastic construction.

E.g. valve cups and connection of upper part to container, e.g. plastic valve cups.

References

Limiting references

This place does not cover:

For delivery of liquid or semi-liquid contents by internal gaseous pressure, i.e. aerosol containers	B65D 83/14
--	----------------------------

B65D 83/42

Filling or charging means

References

Informative references

Attention is drawn to the following places, which may be of interest for search:

Filling liquids into containers	B65B 3/12
Adding propellants to aerosol containers	B65B 31/003

B65D 83/48

Lift valves, e.g. operated by push action ([B65D 83/50](#) takes precedence)

References**Limiting references**

This place does not cover:

Non-reclosable valves, e.g. for complete delivery in a single dose	B65D 83/50
--	----------------------------

Informative references

Attention is drawn to the following places, which may be of interest for search:

Adapted for metering and for continuous delivery	B65D 83/543
--	-----------------------------

B65D 83/56

{with means for preventing delivery, e.g.} shut-off when inverted {(actuating means with means to disable actuation [B65D 83/22](#))}

References**Limiting references**

This place does not cover:

Means for disabling actuation	B65D 83/22
Closure caps	B65D 83/40

Informative references

Attention is drawn to the following places, which may be of interest for search:

Hand-held spraying apparatuses (without any pressure built inside the container) comprising means for preventing delivery	B05B 11/0027
---	------------------------------

Special rules of classification

If an aerosol container comprises both, means for disabling actuation and means for preventing delivery, the document shall be classified in [B65D 83/22](#) and [B65D 83/56](#) even if these means are linked.

Example: US4542837 discloses a dome actuator (10) fitted to an aerosol container (12) wherein rotation of the upper part (14) of the dome actuator raises an actuating member (22) which actuates the dispensing valve when in a fully raised position, i.e. if the upper part (14) is rotated enough.

Pressure on the actuating member (22) in a partially raised position will tend to lower it to its flush position with the top panel (24) and thereby will not actuate the dispensing valve. This aspect is classified in [B65D 83/56](#) since delivery is prevented and actuating is not disabled.

The fact that the actuator in the retracted position is immovable, i.e. locked is classified in [B65D 83/22](#).

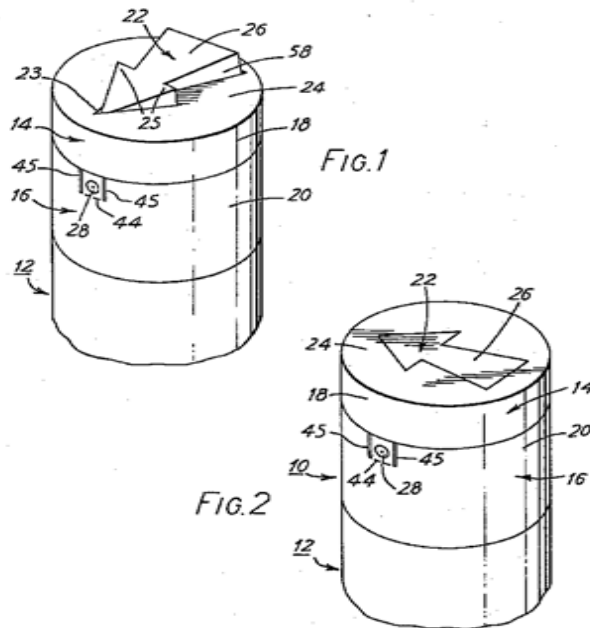

B65D 83/60

Contents and propellant separated

References

Informative references

Attention is drawn to the following places, which may be of interest for search:

Mixing in the dispensing head	B65D 83/66
portable fire extinguishers wherein extinguishing material and pressure gas are stored in separate containers	A62C 13/66

B65D 83/62

by membrane, bag, or the like {(containers in which the content is delivered by the contracting forces inherent in the bag [B65D 83/0061](#))}

References

Limiting references

This place does not cover:

Self-contracting bag without propellant	B65D 83/0061
Spraying apparatus for discharge of liquids or other fluent material, without essentially mixing with gas or vapour supply being effected by follower in container	B05B 9/047

B65D 83/64**by piston****References****Limiting references***This place does not cover:*

Spraying apparatus for discharge of liquids or other fluent material, without essentially mixing with gas or vapour supply being effected by follower in container	B05B 9/047
--	----------------------------

B65D 83/643**{the propellant being generated by a chemical or electrochemical reaction (for pressure gas in portable fire extinguishers [A62C 13/02](#))}****References****Limiting references***This place does not cover:*

For pressure gas in portable fire extinguishers	A62C 13/02
---	----------------------------

B65D 83/646**{the piston being provided with a dispensing opening through which the contents are dispensed (containers with such a dispensing piston, adapted for hand-held, manually operated spray apparatus [B05B 11/029](#), in general [B65D 83/0044](#))}****Definition statement***This place covers:*

E.g. pistons moving along a dispensing tube

References**Limiting references***This place does not cover:*

Containers or packages with special means for dispensing contents provided with a piston having a dispensing opening formed in the piston	B65D 83/0044
---	------------------------------

B65D 83/66

first separated, but finally mixed {, e.g. in a dispensing head}

References**Informative references**

Attention is drawn to the following places, which may be of interest for search:

Mixing in general	B01F
-------------------	----------------------

B65D 83/687

{the products being totally mixed on, or prior to, first use, e.g. by breaking an ampoule containing one of the products}

References**Informative references**

Attention is drawn to the following places, which may be of interest for search:

packaging two or more different materials which must be maintained separate prior to use in admixture	B65D 81/32
---	----------------------------

B65D 83/752

{characterised by the use of specific products or propellants}

References**Limiting references**

This place does not cover:

Biocides, pest repellents or attractants, or plant growth regulators	A01N 25/06
Milk preparations, yogurts, cream	A23C
Coffee; Coffee substitutes; Preparations thereof	A23F 5/243
Cosmetics or similar toiletry preparations	A61K 8/00
Medicinal preparations	A61K 9/12
Air fresheners	A61L
Sterilising materials	A61L 2/22
Paints, varnishes or lacquers	C09D 5/02
Aerosol compositions	C09K 3/30
Lubricants	C10N 2050/04
Detergent materials	C11D 17/0043

B65D 83/756

{comprising connectors, e.g. for tyre valves, or actuators connected to the aerosol container by a flexible tube (auto-repairing or self-sealing arrangement for repairing plastic articles [B29C 73/16](#))}

References**Informative references**

Attention is drawn to the following places, which may be of interest for search:

Auto-repairing or self-sealing arrangement or agents	B29C 73/16
--	----------------------------

B65D 85/00

Containers, packaging elements or packages, specially adapted for particular articles or materials ([B65D 71/00](#), [B65D 83/00](#) take precedence; hand implements or travelling equipment [A45C](#); cosmetic or toiletry equipment [A45D](#); packages for surgical knives, scalpels or blades therefor [A61B 17/3215](#); containers specially adapted for medical or pharmaceutical purposes [A61J 1/00](#); paint cans [B44D 3/12](#); oil cans [F16N 3/04](#); containers for carrying small arms [F41C 33/06](#); packaging of ammunition or explosive charges [F42B 39/00](#); containers for record carriers, specially adapted for cooperation with the recording or reproducing apparatus [G11B 23/00](#))

References**Limiting references**

This place does not cover:

Bundles of articles held together by packaging elements for convenience of storage or transport	B65D 71/00
Containers or packages with special means for dispensing contents	B65D 83/00
Hand implements or travelling equipment	A45C
Cosmetic or toiletry equipment	A45D
Packages for surgical knives, scalpels or blades therefor	A61B 17/3215
Containers specially adapted for medical or pharmaceutical purposes	A61J 1/00
Paint cans	B44D 3/12
Oil cans	F16N 3/04
Containers for carrying small arms	F41C 33/06
Packaging for ammunition or explosive charges	F42B 39/00
Containers for record carriers, specially adapted for cooperation with the recording or reproducing apparatus	G11B 23/00

Special rules of classification

Except for [B65D 85/10](#) and subgroups, [B65D 85/67](#) and subgroups, and [B65D 85/804](#) and subgroups, the documents should as far as possible also be classed in the relevant groups of [B65D 1/00](#) - [B65D 83/00](#).

B65D 85/04**for coils of wire, rope or hose****Definition statement***This place covers:*

Illustrative example of subject matter classified in this group.

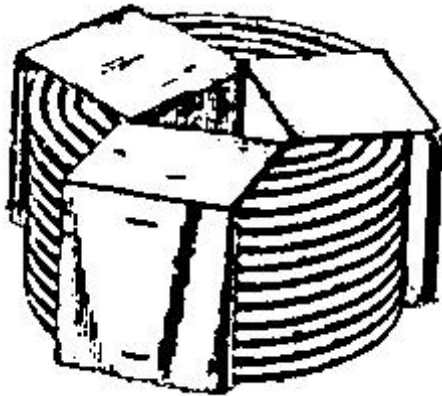
**References****Informative references***Attention is drawn to the following places, which may be of interest for search:*

Containers, packaging elements or packages for other web or tape-like material wound in helical form	B65D 85/675
Containers, packaging elements or packages for other web or tape-like material wound in helical form on cores	B65D 85/676
Containers, packaging elements or packages for other web or tape-like material wound in helical form on flat cards	B65D 85/677
Storing webs, tapes, or filamentary material	B65H 75/00

B65D 85/06**for tyres****Definition statement***This place covers:*

Illustrative example of subject matter classified in this group.

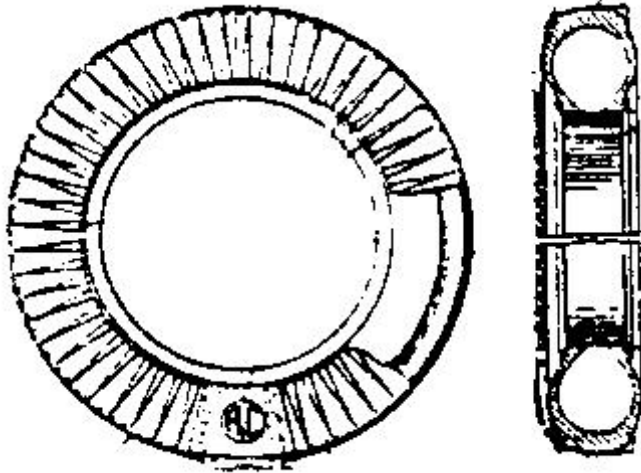
**References****Limiting references***This place does not cover:*

Wheels per se	B60B
Tyres per se	B60C

B65D 85/10**for cigarettes****References****Limiting references***This place does not cover:*

Cigar or cigarette receptacles or boxes	A24F 15/00
---	----------------------------

B65D 85/1009

{provided with proffering means ([B65D 85/1054](#) takes precedence)}

Definition statement

This place covers:

Illustrative example of subject matter classified in this group.

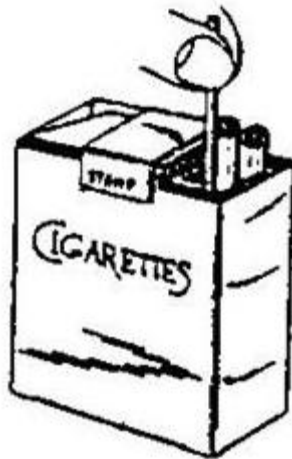
**References****Limiting references**

This place does not cover:

Containers formed by erecting a rigid or semi-rigid blank combined with an outer sleeve connected to the lid	B65D 85/1054
--	------------------------------

Informative references

Attention is drawn to the following places, which may be of interest for search:

Internal elements supporting the contents and movable for displaying them, e.g. movable bottoms or trays	B65D 5/5213
--	-----------------------------

B65D 85/1018**{Container formed by a flexible material, i.e. soft-packages}****Definition statement***This place covers:*

Illustrative example of subject matter classified in this group.

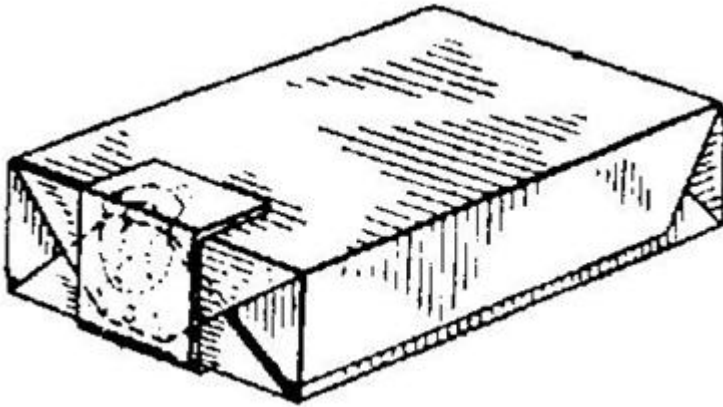
**References*****Limiting references****This place does not cover:*

Provided with proffering means	B65D 85/1009
Bundle of cigarette packs	B65D 85/1072
Inserts or accessories added or joined to the container, e.g. coins, pens, cards, spacers	B65D 85/1081

B65D 85/1027**{Opening devices}****Definition statement***This place covers:*

Illustrative example of subject matter classified in this group.

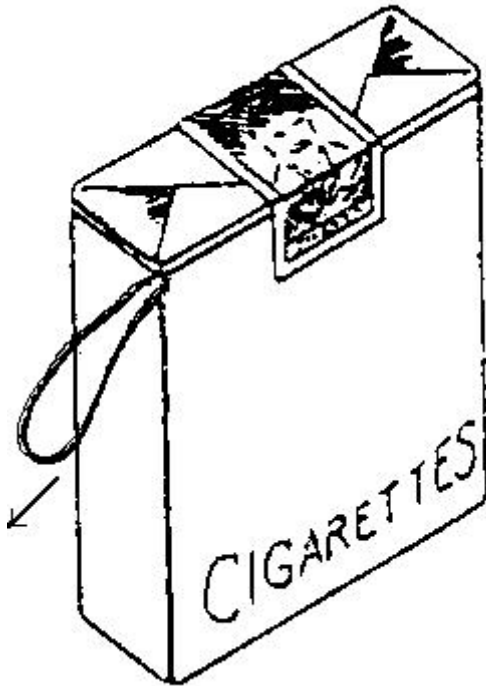
**References****Informative references***Attention is drawn to the following places, which may be of interest for search:*

Inserted or applied tearing-strings or like flexible elements extending through wrapper closure or between wrapper layers	B65D 75/68
Rigid cutting or tearing devices	B65D 75/70
Tearing-strings or like flexible elements	B65D 77/32

B65D 85/1036**{Containers formed by erecting a rigid or semi-rigid blank}****References****Limiting references***This place does not cover:*

Provided with proffering means	B65D 85/1009
Bundle of cigarette packs	B65D 85/1072

Inserts or accessories added or joined to the container, e.g. coins, pens, cards, spacers	B65D 85/1081
---	------------------------------

Informative references

Attention is drawn to the following places, which may be of interest for search:

Containers of polygonal cross-section, e.g. boxes, cartons, trays, formed by folding or erecting one or more blanks made of paper	B65D 5/00
---	---------------------------

B65D 85/1045

{having a cap-like lid hinged to an edge}

Definition statement

This place covers:

Illustrative example of subject matter classified in this group.



Special rules of classification

Containers erectable or foldable from a blank having a cap like lid, e.g. flip-top lids, and specifically for cigarettes are classified in the [B65D 85/1045](#) and sub-groups. Otherwise they are classified in the various [B65D 5/66](#) groups.

B65D 85/1048

{characterized by the shape of the container}

Definition statement

This place covers:

Illustrative example of subject matter classified in this group.

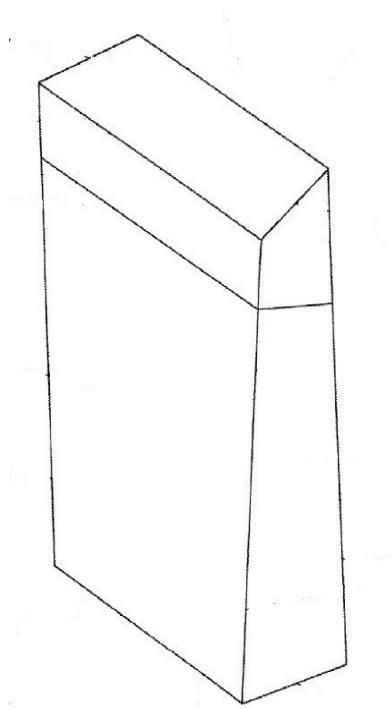

References

Informative references

Attention is drawn to the following places, which may be of interest for search:

the container body having a pyramidal shape	B65D 5/008
the tubular body presenting a special shape	B65D 5/029

B65D 85/10484

{having rounded corners}

Definition statement

This place covers:

Illustrative example of subject matter classified in this group.

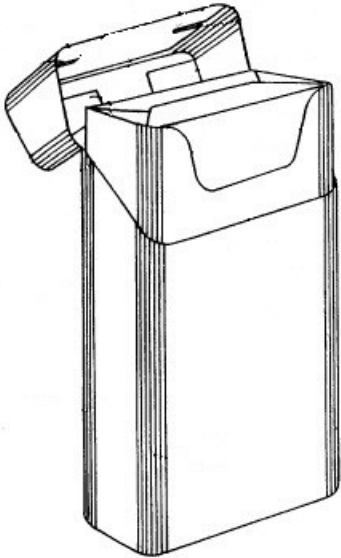

B65D 85/1054

{combined with an outer sleeve connected to the lid}

Definition statement

This place covers:

Illustrative example of subject matter classified in this group.

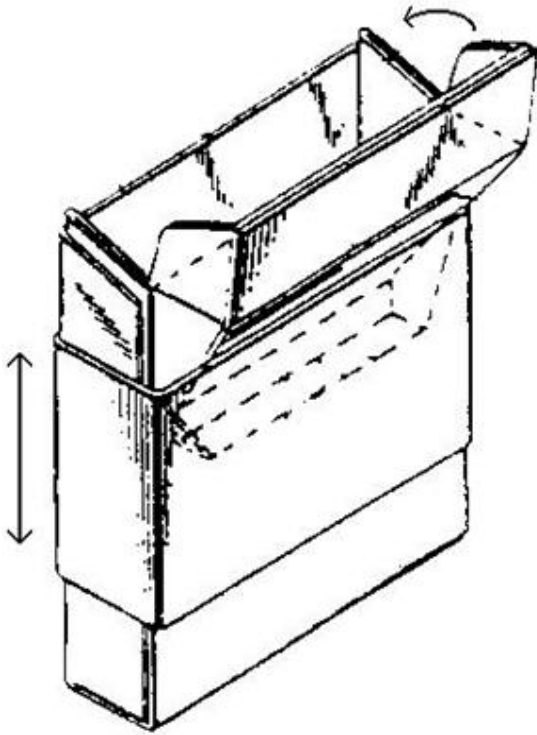
**References****Informative references**

Attention is drawn to the following places, which may be of interest for search:

Drawer-and-shell type containers	B65D 5/38
The container body sliding in an outer sleeve	B65D 5/6688
Contents-dispensing means	B65D 5/728
Containers, packaging elements or packages for cigarettes provided with proffering means	B65D 85/1009

B65D 85/10564**{having means for holding the lid in a closed position}****Definition statement***This place covers:*

Illustrative example of subject matter classified in this group.

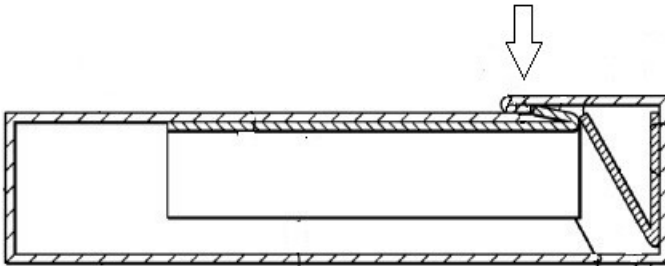
**References****Informative references***Attention is drawn to the following places, which may be of interest for search:*

Containers of polygonal cross-section the container being provided with an internal frame or the like for maintaining the lid in the closed position by friction	B65D 5/543
Container body formed by erecting a tubular blank having a lid being held in closed position by self-locking integral flaps	B65D 5/6608
Container body formed by erecting a tubular blank being provided with an internal frame or the like for maintaining the lid in the closed position by friction	B65D 5/662
Container body formed by erecting a "cross-like" blank and being provided with an internal frame or the like for maintaining the lid in the closed position by friction	B65D 5/6679
Container body formed by erecting a blank to U-shape and being provided with an internal frame or the like for maintaining the lid in the closed position by friction	B65D 5/6691

B65D 85/10566**{having means for holding the lid in an open position}****Definition statement***This place covers:*

Illustrative example of subject matter classified in this group.

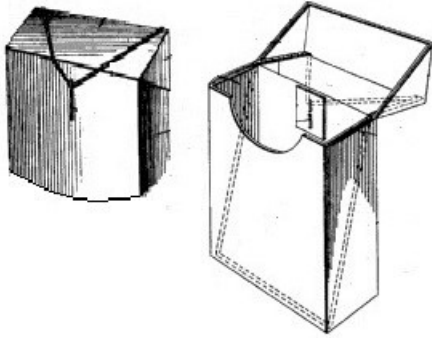
**References*****Informative references****Attention is drawn to the following places, which may be of interest for search:*

Container body formed by erecting a tubular blank having a lid with means for retaining the lid in the open position	B65D 5/6614
Container body formed by erecting a "cross-like" blank and the lid having means for retaining the lid in the open position	B65D 5/6676

B65D 85/10568

{opening of the lid opens simultaneously an inner package within the container}

Definition statement

This place covers:

Illustrative example of subject matter classified in this group.

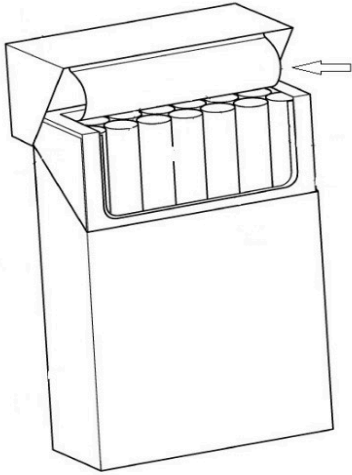

B65D 85/1063

{so as to form two cigarette-compartments interconnected by a hinge-portion}

Definition statement

This place covers:

Illustrative example of subject matter classified in this group.

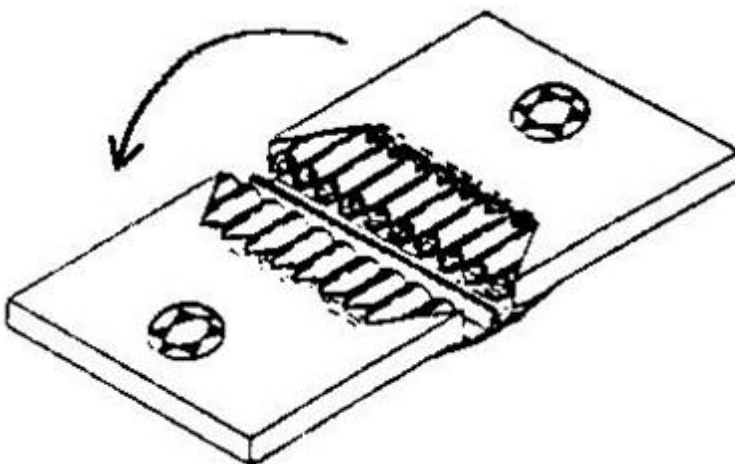

B65D 85/1072

{Bundle of cigarette packs}

Definition statement

This place covers:

Illustrative example of subject matter classified in this group.

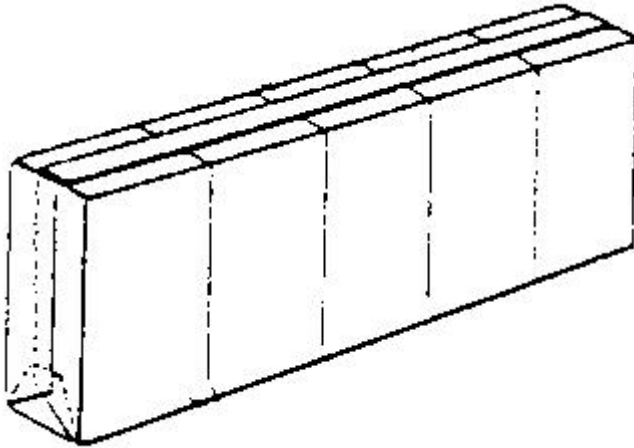

References

Informative references

Attention is drawn to the following places, which may be of interest for search:

Packages formed by enclosing articles or materials in preformed containers, e.g. boxes, cartons, sacks, bags	B65D 77/00
--	----------------------------

B65D 85/1081

{Inserts or accessories added or joined to the container, e.g. coins, pens, cards, spacers ([B65D 85/1009](#) takes precedence)}

Definition statement

This place covers:

Illustrative example of subject matter classified in this group.

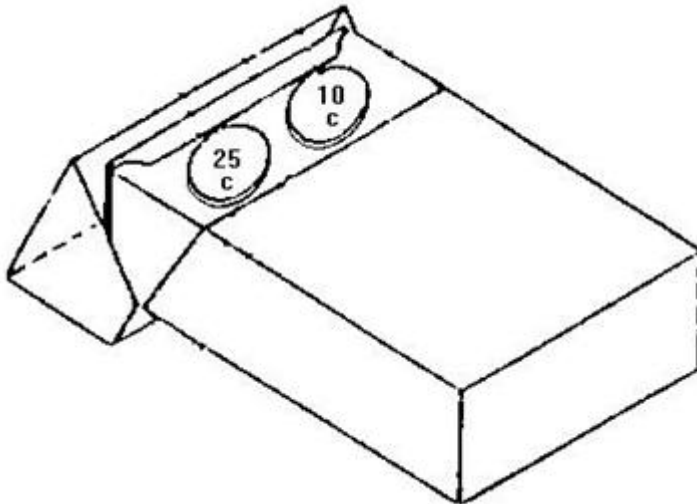
**References****Limiting references**

This place does not cover:

Containers, packaging elements or packages specially adapted for particular articles or materials provided with proffering means	B65D 85/1009
Ashtrays	B65D 2209/00

Informative references

Attention is drawn to the following places, which may be of interest for search:

Cards, coupons, or other inserts or accessories	B65D 75/54
Inserts or accessories added or incorporated during filling of containers	B65D 77/24
Adaptations for preventing deterioration or decay of contents; Applications to the container or packaging material of food preservatives, fungicides, pesticides or animal repellents	B65D 81/24
Cigar or cigarette receptacles or boxes combined with other objects	A24F 15/18

B65D 85/109

{Lighting means, e.g. matches or lighters}

Definition statement

This place covers:

Illustrative example of subject matter classified in this group.

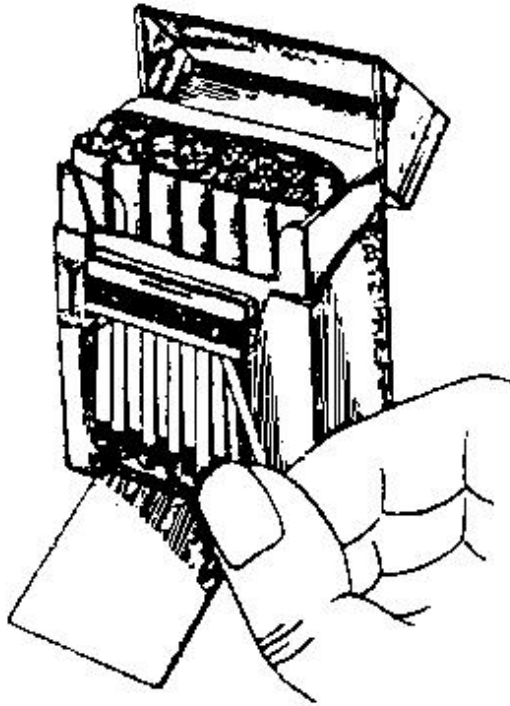

B65D 85/12

for cigars

Definition statement

This place covers:

Illustrative example of subject matter classified in this group.

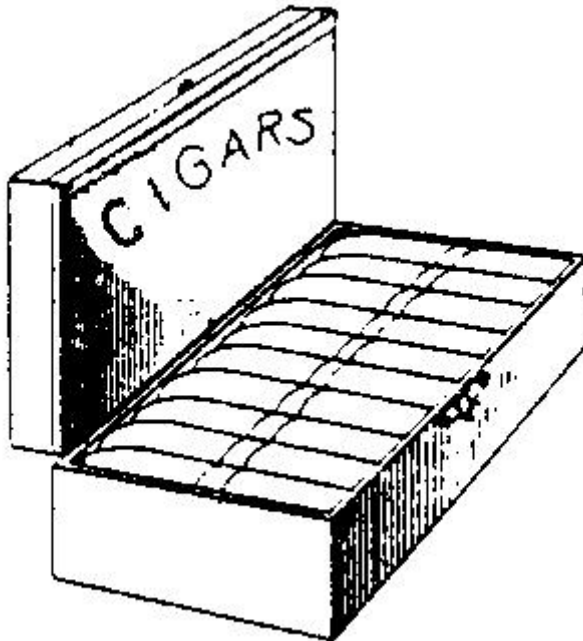

References

Informative references

Attention is drawn to the following places, which may be of interest for search:

Cigar or cigarette receptacles or boxes	A24F 15/00
---	----------------------------

B65D 85/14

for collapsible {empty} tubes

Definition statement

This place covers:

Collapsible tubes, rod-shaped or tubular, for compressible or flexible articles, e.g. pliable tubular containers adapted to be permanently or temporarily deformed to expel contents, such as empty tooth-paste tubes to be filled.

B65D 85/18

for wearing apparel, headwear or footwear

References***Informative references***

Attention is drawn to the following places, which may be of interest for search:

Bags for gloves	A41D 19/00
-----------------	----------------------------

B65D 85/182

{Shirt packaging and display supports}

Definition statement

This place covers:

Illustrative example of subject matter classified in this group.

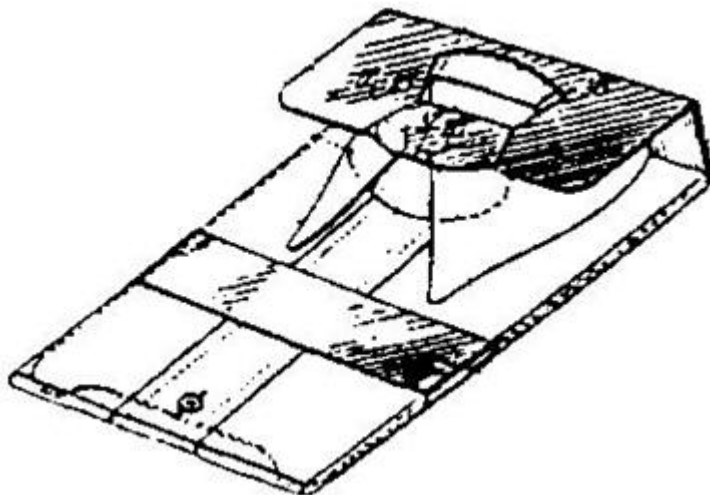
**References*****Limiting references***

This place does not cover:

Collar protectors	A41B 3/18
Apparatus for folding textile articles to be worn, e.g. shirts	D06F 89/023

B65D 85/185

{Containers for shipping garments on hangers (travelling or trunk wardrobes [A47B 61/06](#))}

Definition statement

This place covers:

Illustrative example of subject matter classified in this group.

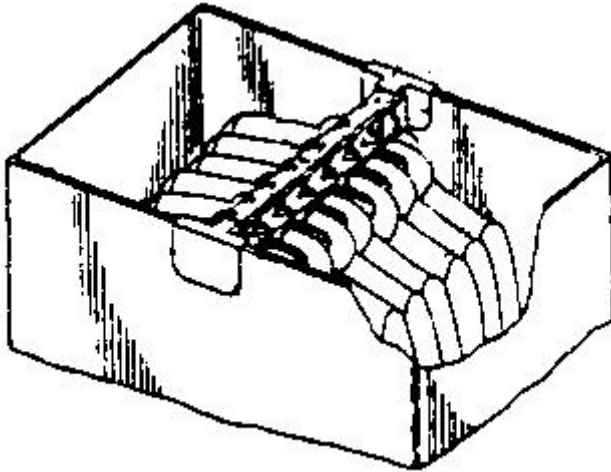
**B65D 85/187**

{for footwear}

References**Limiting references**

This place does not cover:

Socks or the like	B65D 85/18
Bags for shoes	A45C 3/12

B65D 85/20

for incompressible or rigid rod-shaped or tubular articles

References**Limiting references**

This place does not cover:

Trays for tools or instruments for workshops	B25H 3/06
Common support for several parallel pipes	F16L 3/223
Packaging or storage for arrows or darts	F42B 39/007

B65D 85/24

for needles, nails or like elongate small articles

References**Limiting references**

This place does not cover:

Dispensers	B65D 83/02
Holders or packages for surgical needles or suture materials	A61B 17/06
Nail magazine	B25C 3/00
Holders for drill bits or the like	B25H 3/003
Nails or staples formed in integral series but easily separable	F16B 15/08

B65D 85/30

for articles particularly sensitive to damage by shock or pressure

References**Limiting references**

This place does not cover:

Protection rings	B65D 85/307
------------------	-----------------------------

B65D 85/302

{for carboys}

Definition statement

This place covers:

Illustrative example of subject matter classified in this group.

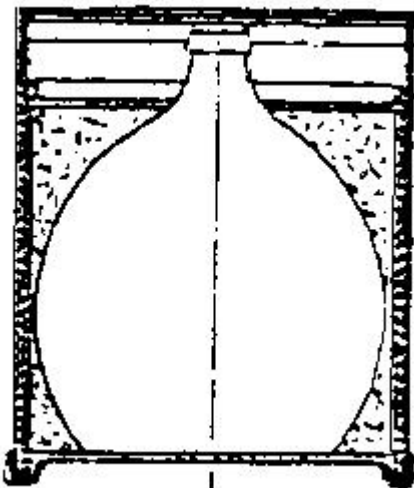

B65D 85/305

{**Bottle-crates (formed in one piece [B65D 1/243](#))**}

Definition statement

This place covers:

Illustrative example of subject matter classified in this group.

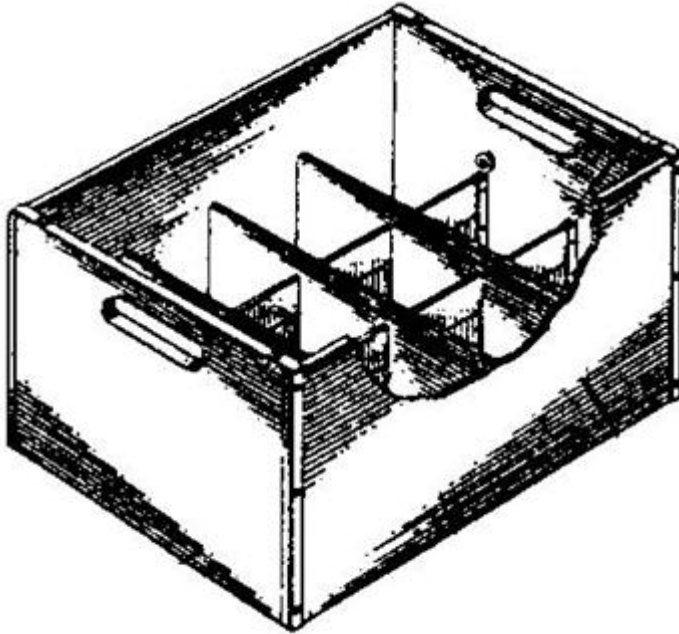

B65D 85/307**{Local shock-absorbing elements, e.g. elastic rings}****Definition statement***This place covers:*

Illustrative example of subject matter classified in this group.

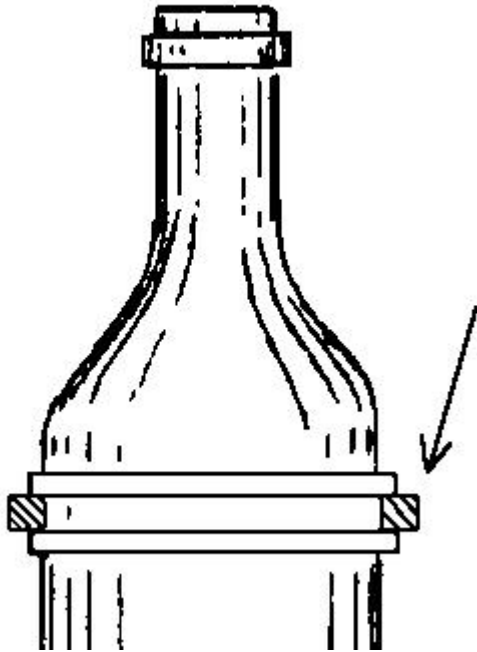
**B65D 85/32****for eggs****References****Limiting references***This place does not cover:*

Eggs suspended in a container	B65D 81/07
For Easter or chocolate eggs	B65D 85/60

B65D 85/321

{Trays made of pressed carton and provided with recesses}

Definition statement

This place covers:

Illustrative example of subject matter classified in this group.

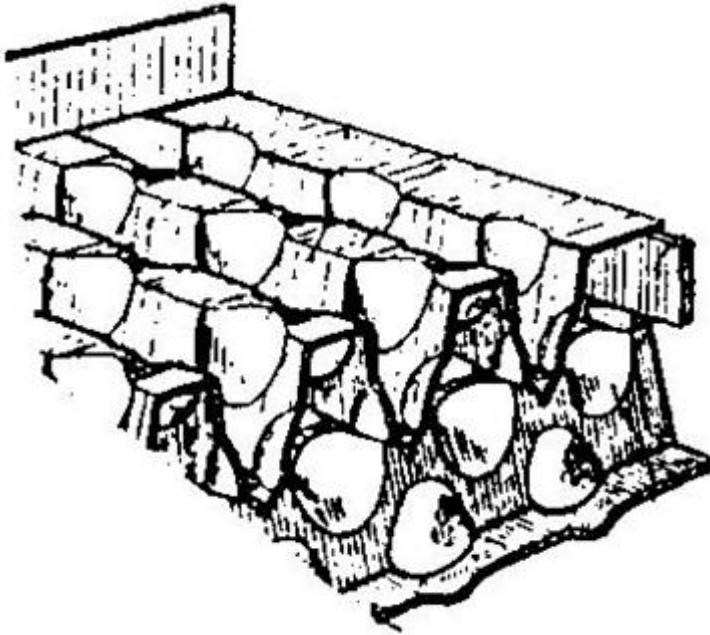

B65D 85/322

{Trays made of pressed material, e.g. paper pulp}

Definition statement

This place covers:

Illustrative example of subject matter classified in this group.



B65D 85/324

{Containers with compartments made of pressed material}

Definition statement

This place covers:

Illustrative example of subject matter classified in this group.

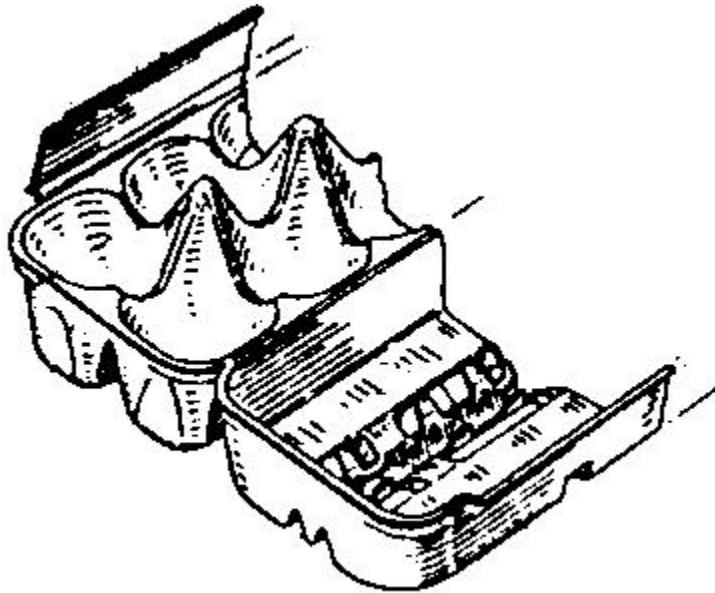

B65D 85/325

{Containers with compartments formed by erecting one blank}

Definition statement

This place covers:

Illustrative example of subject matter classified in this group.

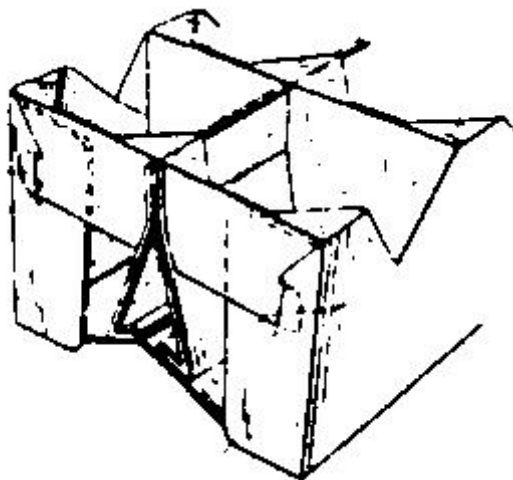

B65D 85/327

{Containers with compartments formed by folding and inter-connecting of two or more blanks}

Definition statement

This place covers:

Illustrative example of subject matter classified in this group.

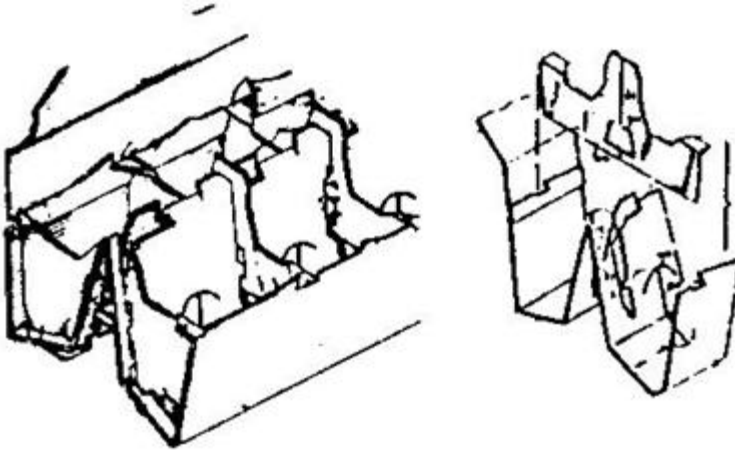
**B65D 85/328**

{Partitions}

Definition statement

This place covers:

Illustrative example of subject matter classified in this group.

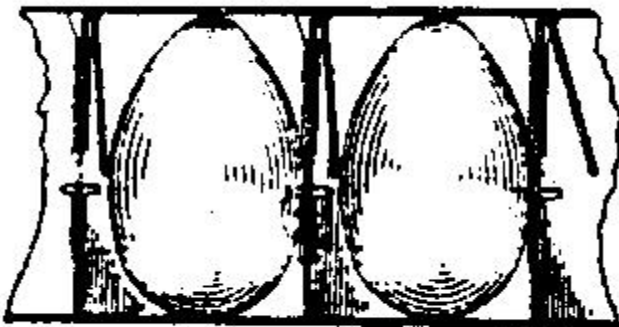
**References****Informative references**

Attention is drawn to the following places, which may be of interest for search:

Squaring or like elements, e.g. honeycomb element, i.e. at least four not aligned compartments	B65D 5/48026
--	------------------------------

B65D 85/34

for fruit, e.g. apples, oranges or tomatoes

Definition statement

This place covers:

Illustrative example of subject matter classified in this group.

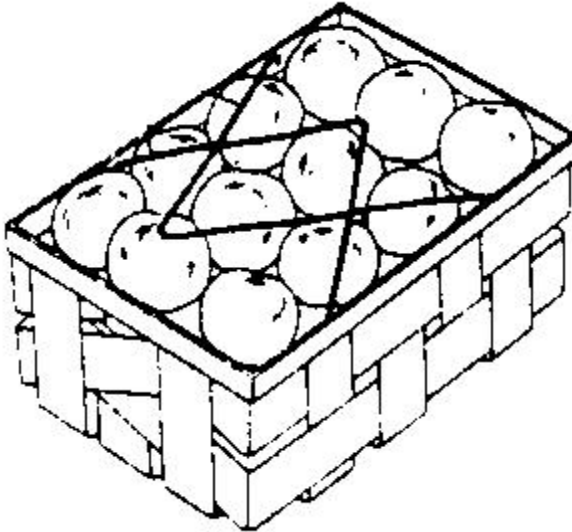

References

Limiting references

This place does not cover:

Separating trays for fruit containers	B65D 65/44
---------------------------------------	----------------------------

B65D 85/345

{having a meshed or apertured closure to allow contents to breathe}

Definition statement

This place covers:

Illustrative example of subject matter classified in this group.

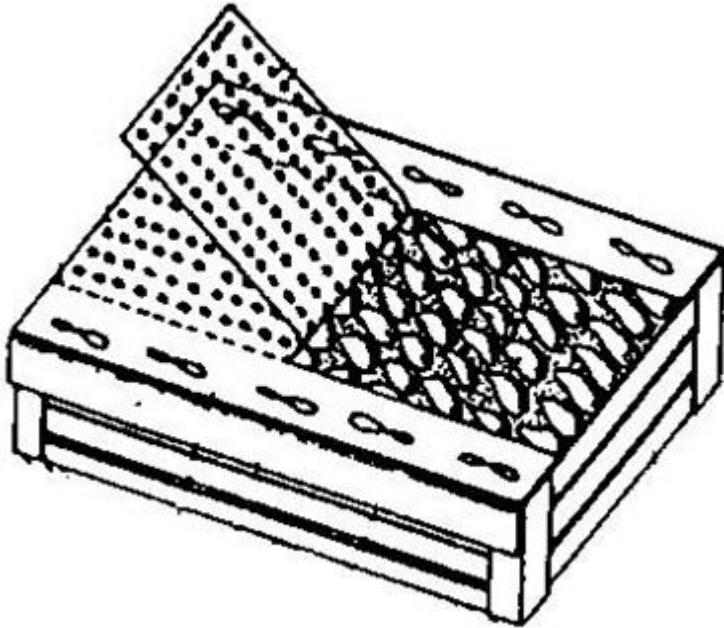
**B65D 85/36**

for bakery products, e.g. biscuits

References**Limiting references**

This place does not cover:

"Clamshell" container made by folding cardboard	B65D 5/667
Protective covers or lids for food containers	A47G 19/26
Holders or wrappers as eating aids for fast food, e.g. hamburgers	A47G 21/001

Special rules of classification

The use of available Indexing Codes is mandatory.

B65D 85/38

for delicate optical, measuring, calculating or control apparatus

References**Limiting references**

This place does not cover:

Contact lenses cases	A45C 11/005
Casings specifically for measuring instruments	G01K

B65D 85/40

for watches or clocks; for components thereof

References**Informative references**

Attention is drawn to the following places, which may be of interest for search:

Receptacles for watches, watch protectors	A45C 11/10
Show stands, hangers or shelves for watches	A47F 7/022
Packaging and boxes for transport of clockworks	G04D 1/066

B65D 85/42

for ampoules; for lamp bulbs; for electronic valves or tubes

References**Limiting references**

This place does not cover:

Sleeves	B65D 59/04
Containers or magazines for electric components, e.g. tube like magazines	H05K 13/0084

B65D 85/46

for bricks, tiles or building blocks

References**Limiting references**

This place does not cover:

Palletisable loads	B65D 71/0088
Bundling bricks or other building blocks	B65B 27/02

Informative references

Attention is drawn to the following places, which may be of interest for search:

For stacks of articles; for special arrangements of groups of articles	B65D 85/62
--	----------------------------

B65D 85/48

for glass sheets

References**Informative references**

Attention is drawn to the following places, which may be of interest for search:

Easels, stands or shelves, e.g. castor-shelves, supporting means on vehicles	B65G 49/062
Means for avoiding damage to stacked plate glass, e.g. by interposing paper or powder spacers in the stack	B65G 49/069
For LCD displays	H01L 21/673

Special rules of classification

Separators for glass sheets: [B65D 57/00](#) (Invention) and [B65D 85/48](#) (Additional).

B65D 85/50

for living organisms, articles or materials sensitive to changes of environment or atmospheric conditions, e.g. land animals, birds, fish, water plants, non-aquatic plants, flower bulbs, cut flowers or foliage (devices for transporting live fish [A01K 63/02](#))

Definition statement

This place covers:

Illustrative example of subject matter classified in this group.

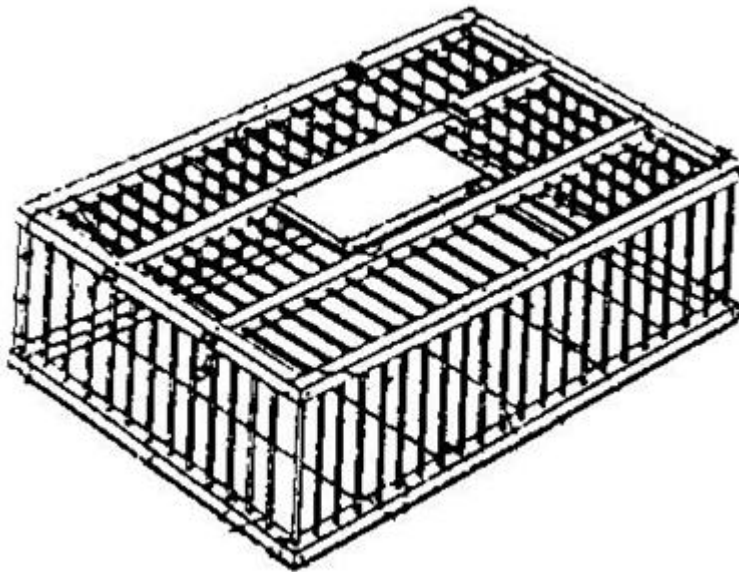
**References****Limiting references**

This place does not cover:

Containers characterised by apertures to ventilate the contents	B65D 81/263 , B65D 85/50
Devices for transporting live animals	A01K 1/0236
Packaging agricultural or horticultural products	B65B 25/02

B65D 85/505**{for cut flowers}****Definition statement***This place covers:*

Illustrative example of subject matter classified in this group.

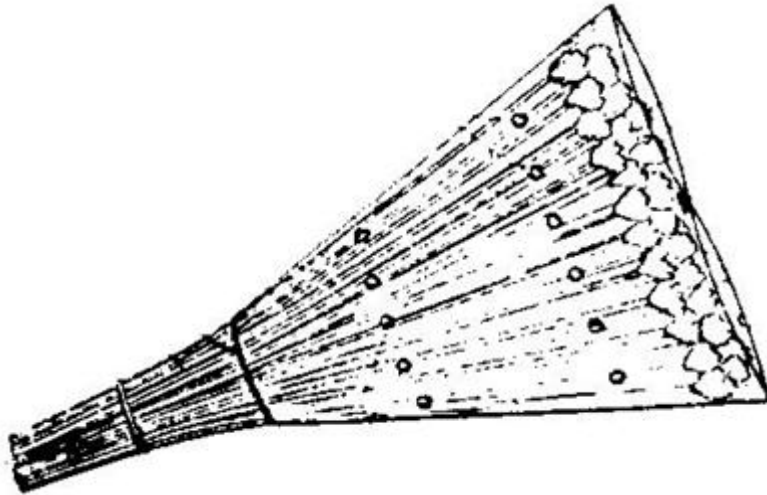
**References****Limiting references***This place does not cover:*

Boxes for cut flowers	B65D 5/5021 , B65D 5/5035 , A01G 5/02
Floral art pieces	B65D 85/52
Floral handling	A01G 5/00
Foldable flower pots	A01G 9/026
Foldable vases	A47G 7/063
Packaging agricultural or horticultural products	B65B 25/02

B65D 85/52

for living plants; for growing bulbs

Definition statement

This place covers:

Illustrative example of subject matter classified in this group.

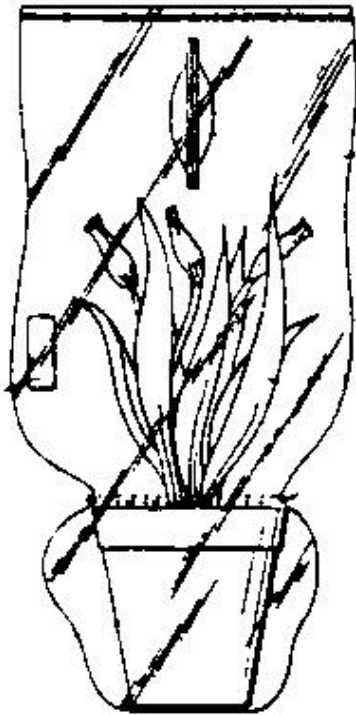
**References****Limiting references**

This place does not cover:

Cartons for potted plants	B65D 5/5035
Seeds which grow in the package	A01G
Pots for growing plants	A01G 9/02
Covers for flower-pots, e.g. ornamental pots	A47G 7/08
Made of flexible sheets of non-resilient material	A47G 7/085
Christmas trees	A47G 33/04
Underlays, mats for catching needles or to aid in disposing of Christmas trees	A47G 33/045
Packaging agricultural or horticultural products	B65B 25/02

B65D 85/542**{for tetrahedral packages}****Definition statement***This place covers:*

Illustrative example of subject matter classified in this group.

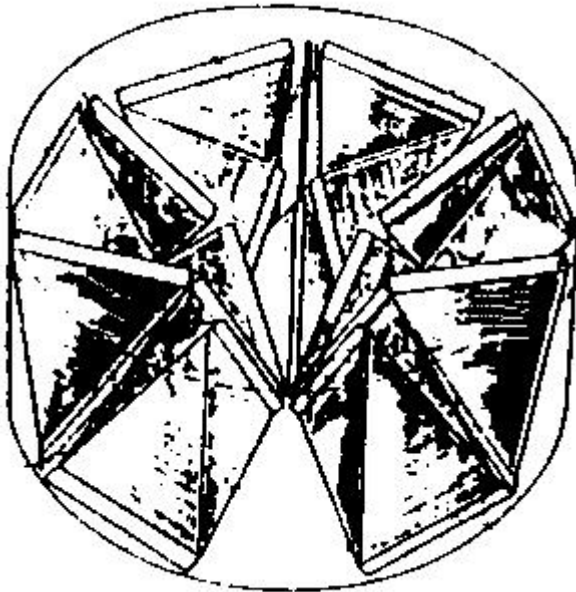
**B65D 85/544****{for gramophone records}****References*****Limiting references****This place does not cover:*

Tape cassettes or CD-packs	G11B
----------------------------	----------------------

B65D 85/546

{formed by folding a single blank}

Definition statement

This place covers:

Illustrative example of subject matter classified in this group.

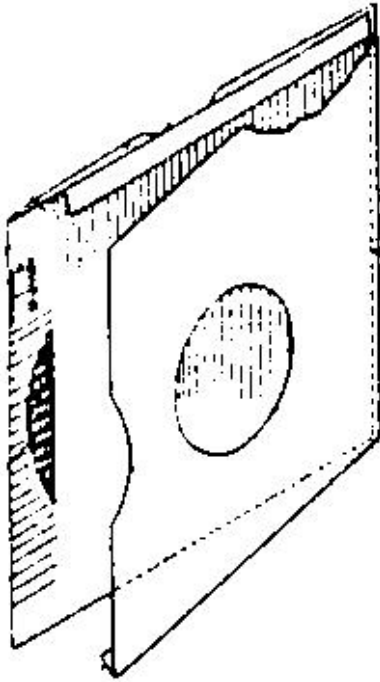

B65D 85/548

{formed by folding or interconnecting of two or more blanks}

Definition statement

This place covers:

Illustrative example of subject matter classified in this group.



B65D 85/58

for ball bearings, washers, buttons or like spherical or disc-shaped articles
(cards for buttons, collar-studs or sleeve-links [A44B 7/00](#))

References**Limiting references**

This place does not cover:

Coin wrappers	G07D 9/006
---------------	----------------------------

B65D 85/62

for stacks of articles; for special arrangements of groups of articles

References**Limiting references**

This place does not cover:

Palletisable loads	B65D 71/0088
Bricks, tiles, or building blocks	B65D 85/46
Coin wrappers	G07D 9/006

B65D 85/64

for bulky articles

Special rules of classification

The use of available Indexing Codes is mandatory.

B65D 85/66

for jumbo rolls; for rolls of floor covering

Definition statement

This place covers:

Illustrative example of subject matter classified in this group.

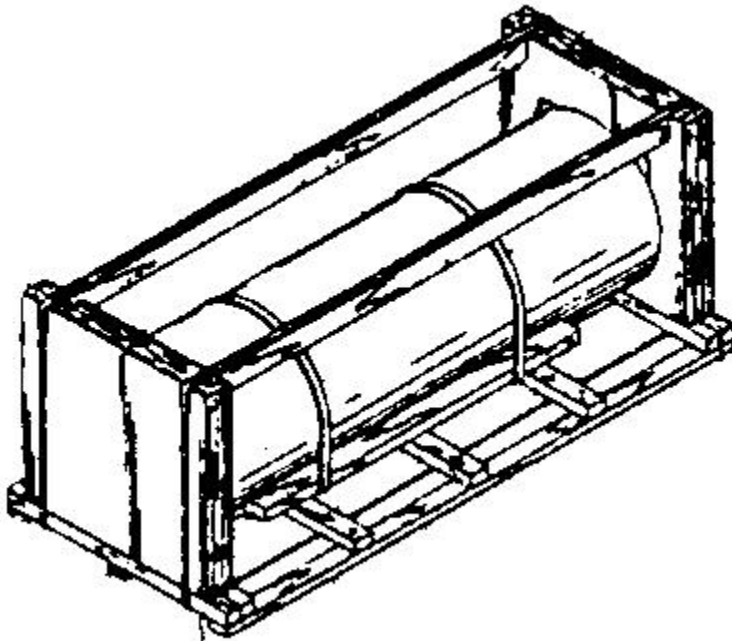
**B65D 85/67**

for web or tape-like material (for jumbo rolls or rolls of floor covering [B65D 85/66](#); for recording-tape cassettes {[G11B 23/00](#)})

References**Limiting references**

This place does not cover:

Fibre materials	B65H
Photo-sensitive paper	G03C 3/00

Informative references

Attention is drawn to the following places, which may be of interest for search:

Containers or packages with special means for dispensing contents, the band being wound in flat spiral, folded in accordion or the like	B65D 83/0472
---	------------------------------

B65D 85/671**wound in flat spiral form****Definition statement***This place covers:*

Illustrative example of subject matter classified in this group.

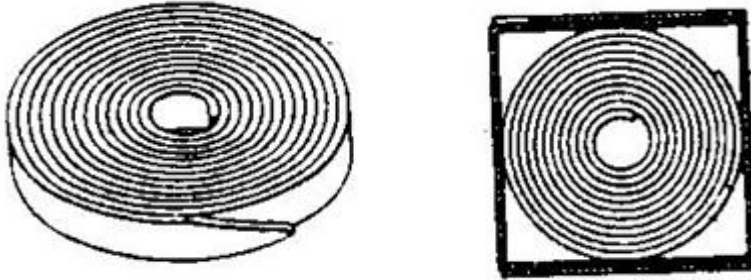
**References****Limiting references***This place does not cover:*

Dispensers provided with knives or cutting means	B65D 83/0841 , B65D 83/0882
--	--

B65D 85/672**on cores****Definition statement***This place covers:*

Illustrative example of subject matter classified in this group.

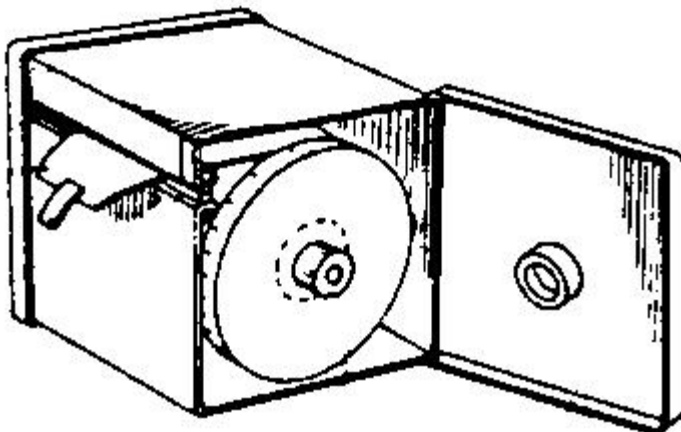

References

Limiting references

This place does not cover:

Dispensers provided with knives or cutting means	B65D 83/0841 , B65D 83/0882
Cores, supports, or holders for coiled, wound, or folded material, e.g. reels, spindles, bobbins, cop tubes	B65H 75/02
Photo-sensitive paper	G03C 3/00

B65D 85/675

wound in helical form

Definition statement

This place covers:

Illustrative example of subject matter classified in this group.

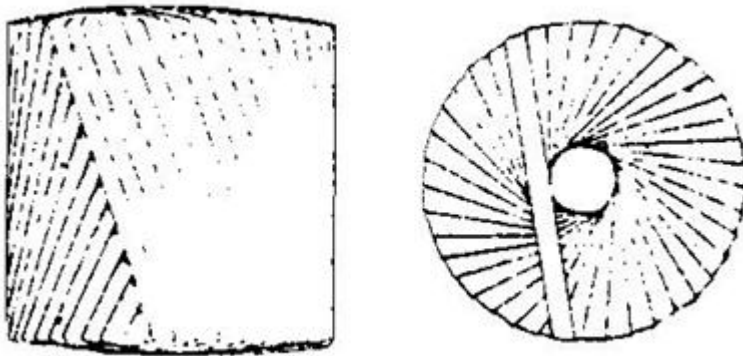

References

Informative references

Attention is drawn to the following places, which may be of interest for search:

For coils of wire, rope, or hose	B65D 85/04
On cores	B65D 85/676
Storing webs, tapes, or filamentary material, e.g. on reels	B65H 75/00

B65D 85/676**on cores****Definition statement**

This place covers:

Illustrative example of subject matter classified in this group.

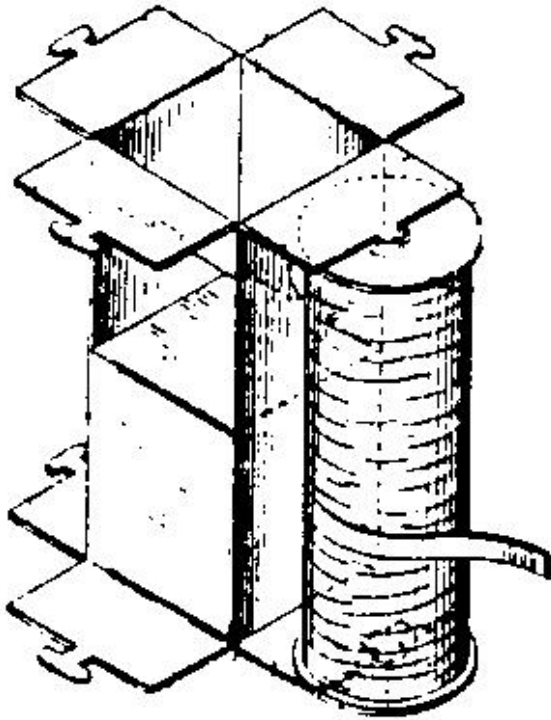
**References****Limiting references**

This place does not cover:

Cores, supports, or holders for coiled, wound, or folded material, e.g. reels, spindles, bobbins, cop tubes	B65H 75/02
---	----------------------------

Informative references

Attention is drawn to the following places, which may be of interest for search:

For coils of wire, rope, or hose	B65D 85/04
On cores	B65D 85/676
Storing webs, tapes, or filamentary material, e.g. on reels	B65H 75/00

B65D 85/677**on flat cards****Definition statement***This place covers:*

Illustrative example of subject matter classified in this group.

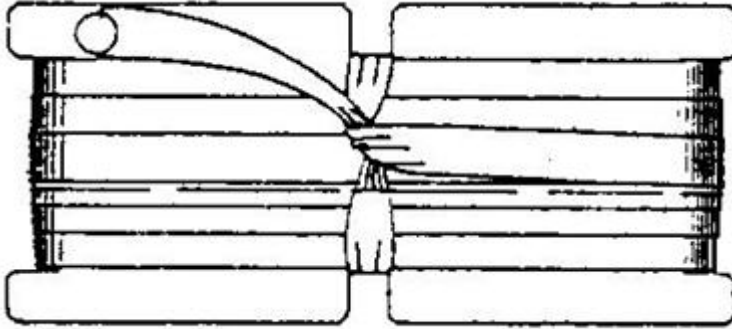
**References****Informative references***Attention is drawn to the following places, which may be of interest for search:*

For coils of wire, rope, or hose	B65D 85/04
Storing webs, tapes, or filamentary material, e.g. on reels	B65H 75/00

B65D 85/68**for machines, engines or vehicles in assembled or dismantled form****References****Limiting references***This place does not cover:*

Tyres, wheels or rims	B65D 85/06
Parking covers for cycles	B62J 19/00
Protective arrangements for use during transport of washing machines	D06F 39/001

Special rules of classification

The use of available Indexing Codes is mandatory.

B65D 85/73

with means specially adapted for effervescing the liquids, e.g. for forming bubbles or beer head

Definition statement

This place covers:

Illustrative example of subject matter classified in this group.

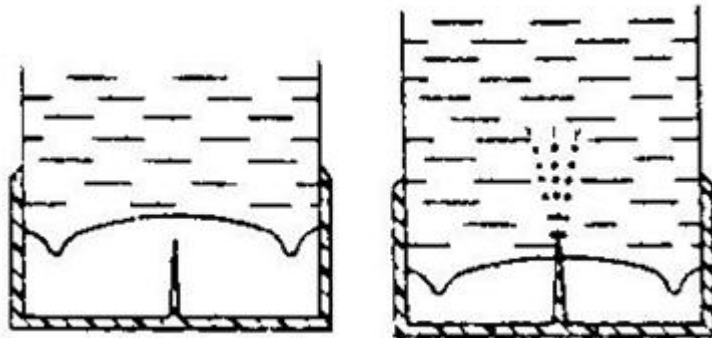
**References****Limiting references**

This place does not cover:

Pressure regulators for aerosols	B62J 19/00
----------------------------------	----------------------------

B65D 85/78

for ice-cream

References**Limiting references**

This place does not cover:

Carriers for several cones	A47G 23/06
----------------------------	----------------------------

B65D 85/804

Disposable containers or packages with contents which are {mixed,} infused or dissolved in situ {, i.e. without having been previously removed from the package ([B65D 65/46](#) takes precedence; tea infusers [A47G 19/16](#); spoons or stirrers comprising beverage additives [A47G 21/04](#))}

References**Limiting references**

This place does not cover:

Applications of disintegrable, dissolvable or edible materials	B65D 65/46
--	----------------------------

Porous packages	B65D 85/808
Packaging of substances, e.g. tea, which are intended to be infused in the package	B65B 29/02

B65D 85/8043

{Packages adapted to allow liquid to pass through the contents
([B65D 85/808](#) takes precedence; filters or reusable cartridges for coffee or tea makers, not used as packages [A47J 31/06](#))}

Definition statement

This place covers:

Illustrative example of subject matter classified in this group.

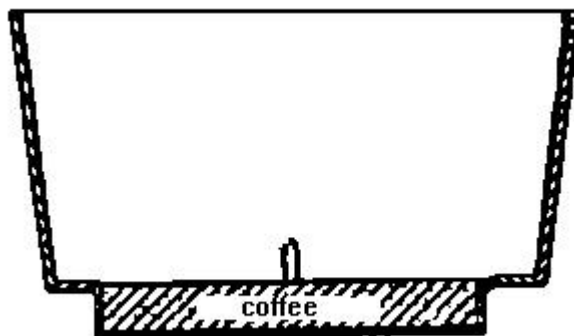

References

Limiting references

This place does not cover:

Disposable containers or packages with contents which are for immersion in the liquid	B65D 85/808
Filters or reusable cartridges for coffee or tea makers, not used as packages	A47J 31/06

B65D 85/8046

{Pods, i.e. closed containers made only of filter paper or similar material}

Definition statement

This place covers:

Illustrative example of subject matter classified in this group.

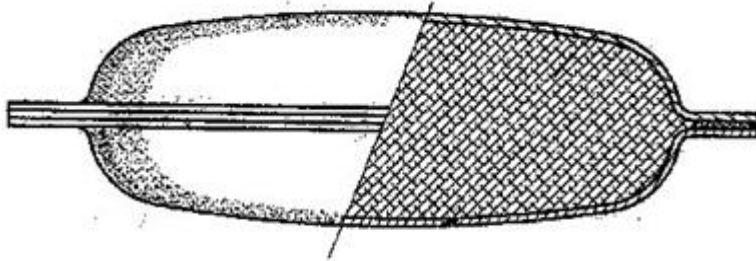

B65D 85/8049

{Details of the inlet}

Definition statement

This place covers:

Illustrative example of subject matter classified in this group.

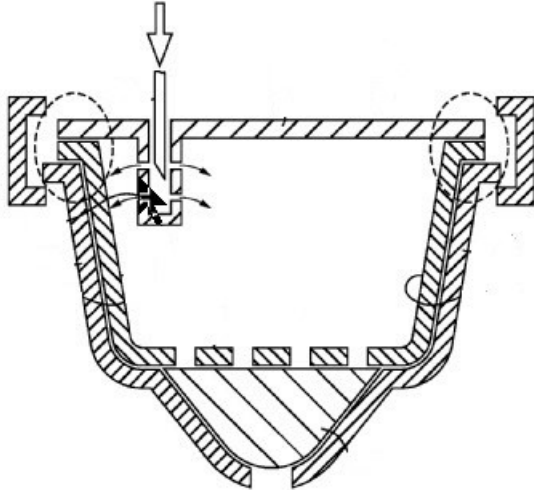

B65D 85/8052

{Details of the outlet}

Definition statement

This place covers:

Illustrative example of subject matter classified in this group.

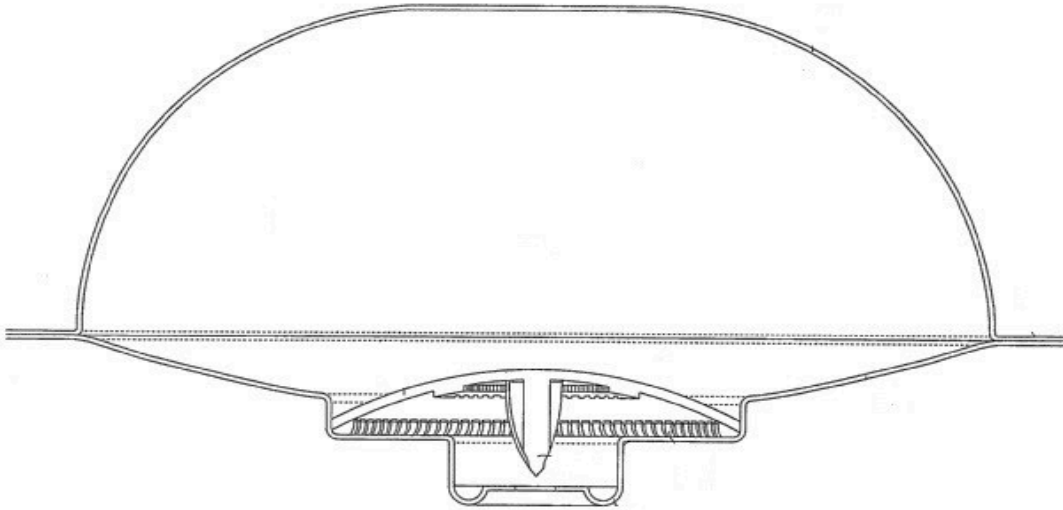

B65D 85/8055

{Means for influencing the liquid flow inside the package}

Definition statement

This place covers:

Illustrative example of subject matter classified in this group.

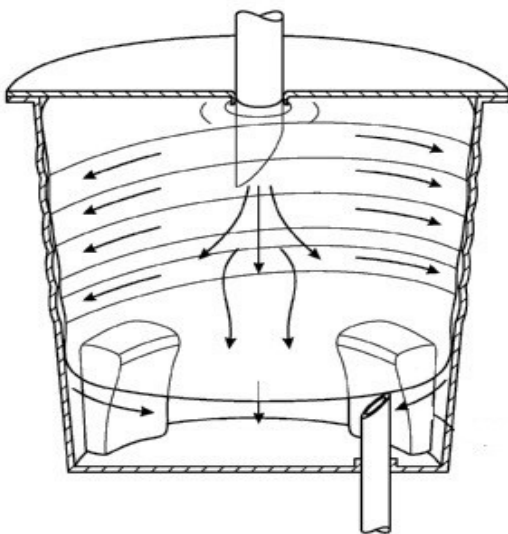

B65D 85/8058

{Coding means for the contents}

Definition statement

This place covers:

Illustrative example of subject matter classified in this group.

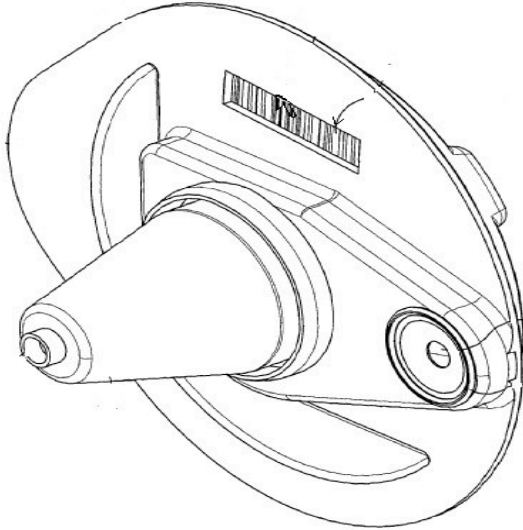

B65D 85/8061

{Filters}

Definition statement

This place covers:

Illustrative example of subject matter classified in this group.
7.42cm

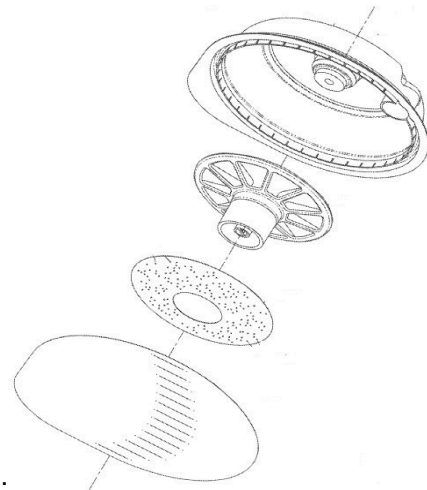

B65D 85/8064

{Sealing means for the interface with the processing machine}

Definition statement

This place covers:

Illustrative example of subject matter classified in this group.

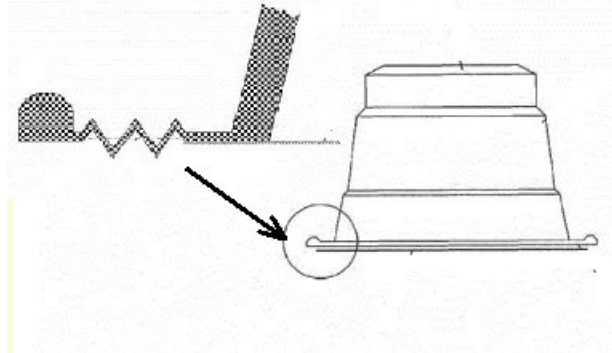

B65D 85/8067

{Packages for several ingredients}

Definition statement

This place covers:

Illustrative example of subject matter classified in this group.

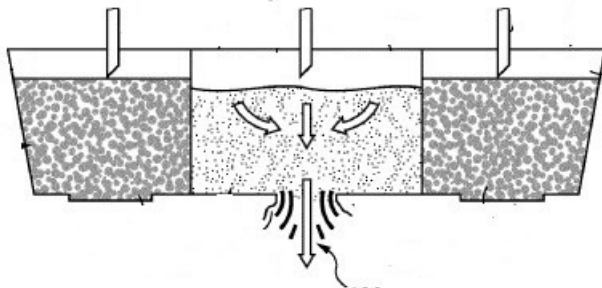

B65D 85/808

for immersion in the liquid {to release part or all of their contents}, e.g. tea bags

Definition statement

This place covers:

Illustrative example of subject matter classified in this group.

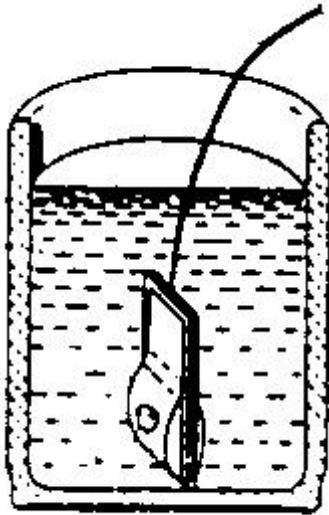

References

Limiting references

This place does not cover:

Dissolvable packages	B65D 65/46
Attaching string handles or tags to tea bags	B65B 29/04

B65D 85/8085

{characterised by an outer package, e.g. wrappers or boxes for enclosing tea-bags}

Definition statement

This place covers:

Illustrative example of subject matter classified in this group.

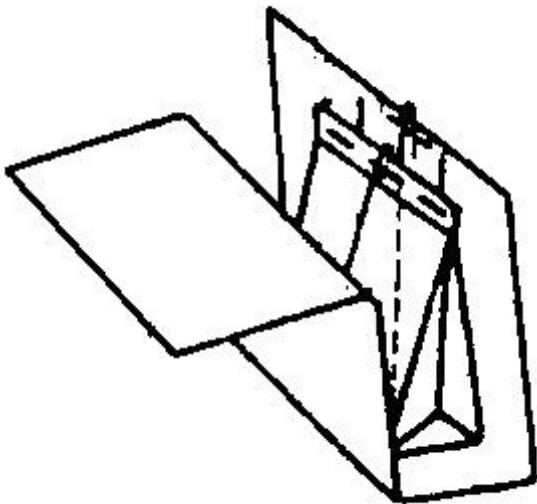

B65D 85/812

with features facilitating their {manipulation or} suspension {(B65D 85/8085 takes precedence)}

Definition statement

This place covers:

Illustrative example of subject matter classified in this group.

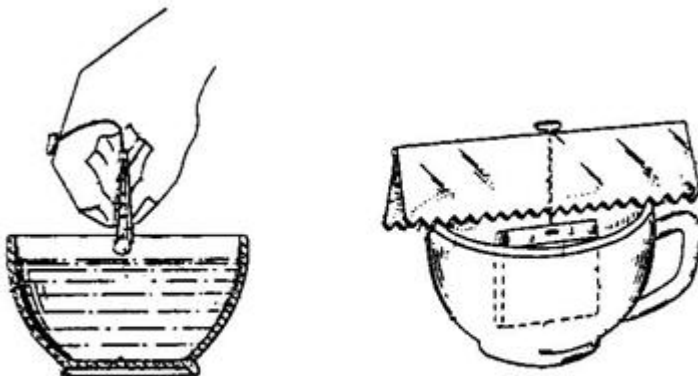

References

Limiting references

This place does not cover:

Disposable containers or packages with contents which are infused or dissolved in situ, characterised by an outer package	B65D 85/8085
---	------------------------------

B65D 85/816

into which liquid is added {and the resulting preparation is retained}, e.g. cups preloaded with powder or dehydrated food

Definition statement

This place covers:

Illustrative example of subject matter classified in this group.

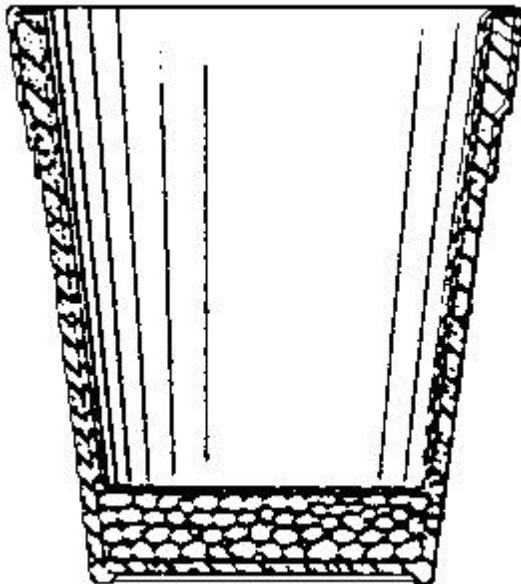

B65D 88/00

Large containers (component parts, details or accessories [B65D 90/00](#); construction or assembling of bulk storage containers employing civil engineering techniques in situ or off the site [E04H 7/00](#); gas holders of variable capacity [F17B](#); vessels for containing or storing compressed, liquefied or solidified gases [F17C](#))

References

Informative references

Attention is drawn to the following places, which may be of interest for search:

Large containers (FTCLA)	3E070
--------------------------	-------

B65D 88/005

{of variable capacity, e.g. with movable or adjustable walls or wall parts, modular}

Definition statement

This place covers:

Illustrative example of subject matter classified in this group:

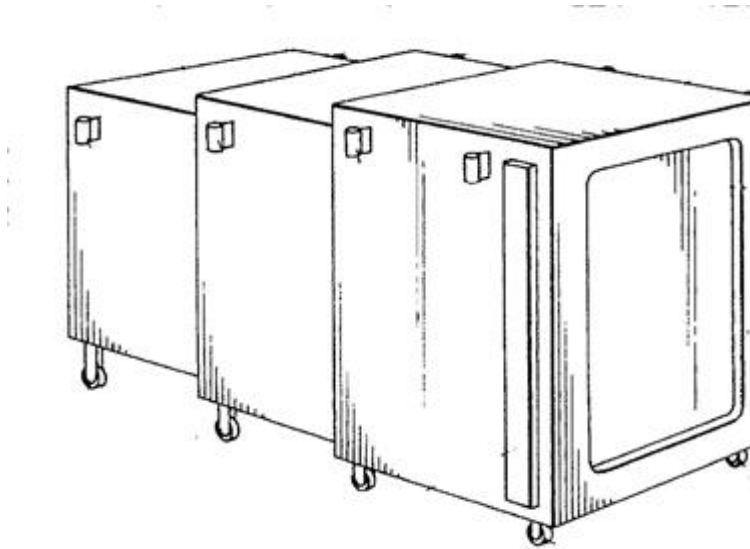
**References****Limiting references**

This place does not cover:

Small containers	B65D 21/02
Flexible container	B65D 88/16
Collapsible container	B65D 88/52

Informative references

Attention is drawn to the following places, which may be of interest for search:

By connecting two or more similar container each other to obtain a larger container	B65D 88/022
Wall construction: modular panels	B65D 90/023
Height adjusting implements and spacers (FTCLA)	3E070/WJ05

B65D 88/02

rigid ([B65D 88/34](#) - [B65D 88/78](#) take precedence; hoppers [B65D 88/26](#); {special vessels for collecting or storing rain-water for use in the household [E03B 3/03](#); cesspools [E03F 11/00](#)})

References**Limiting references**

This place does not cover:

Hoppers	B65D 88/26
Large containers having floating covers; collapsible; characterised by means facilitating filling emptying; having means for heating, cooling, aerating or other conditioning of contents; for use underground; for use in or under water	B65D 88/34 - B65D 88/78

B65D 88/022

{in multiple arrangement, e.g. stackable, nestable, connected or joined together side-by-side}

Definition statement

This place covers:

Illustrative example of subject matter classified in this group:

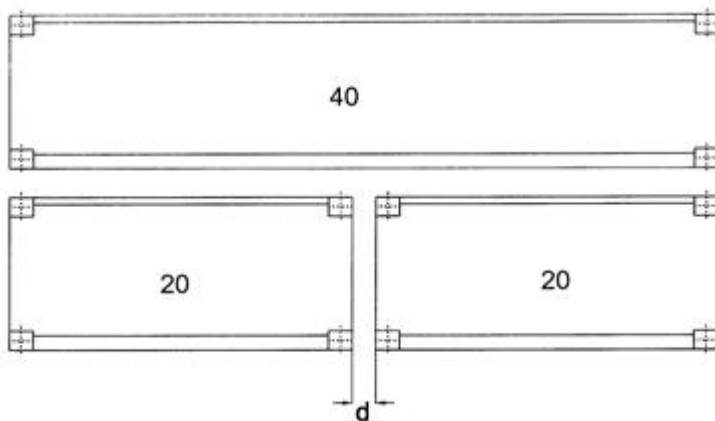
**References****Limiting references**

This place does not cover:

Hoppers	B65D 88/32
Stacking on ships	B63B 25/28

Special rules of classification

For FIBC see Indexing Code [B65D 2588/167](#).

B65D 88/025

{Nestable containers or nestable container parts forming a receptacle when one part is inverted upon the other}

Definition statement

This place covers:

Illustrative examples of subject matter classified in this group:

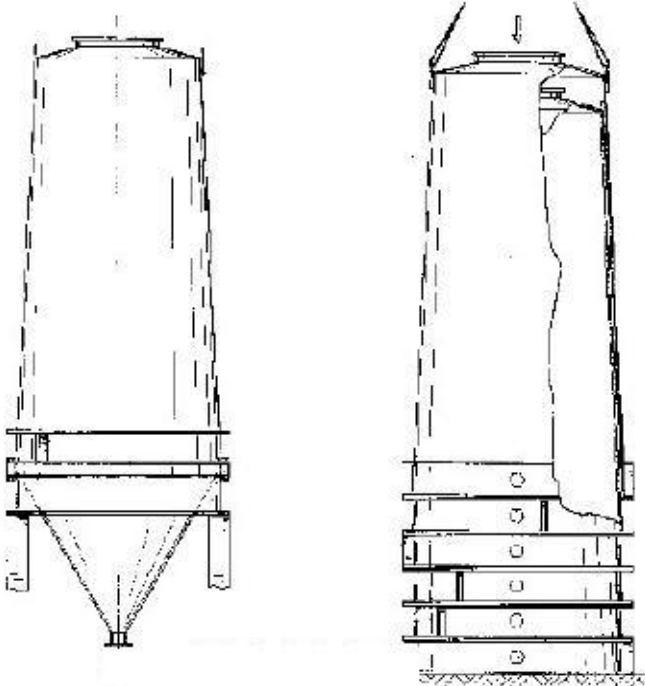
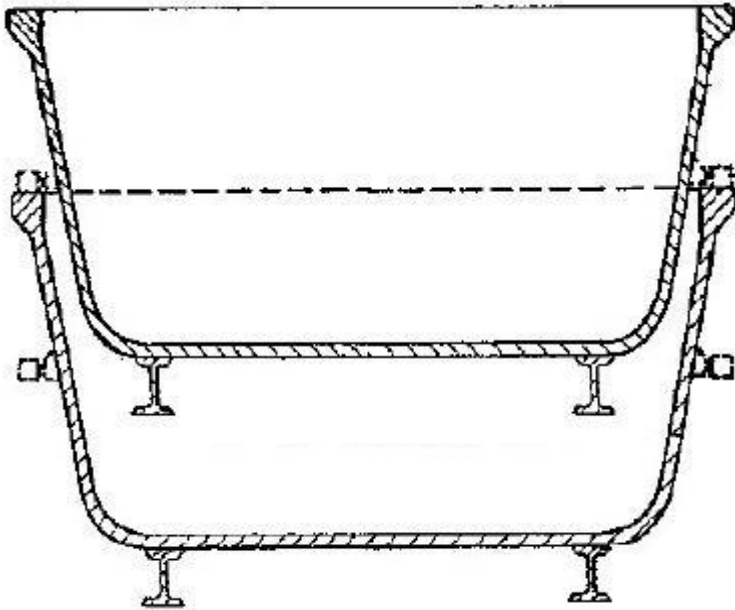

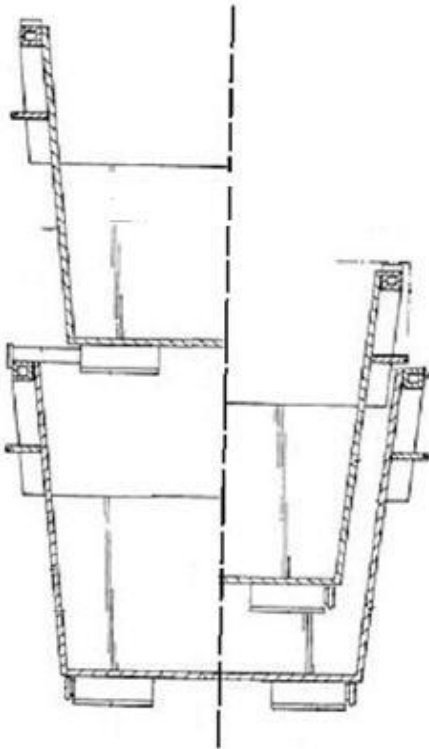

References

Limiting references

This place does not cover:

Nestable and stackable container	B65D 88/022 , B65D 88/025
----------------------------------	--

Informative references

Attention is drawn to the following places, which may be of interest for search:

All side walls detached from each other to collapse the container	B65D 88/528
Modular panels	B65D 90/023

B65D 88/027

{single containers connected to each other by additional means so as to form a cluster of containers, e.g. a battery of containers ([B65D 88/005](#) takes precedence)}

Definition statement

This place covers:

Illustrative example of subject matter classified in this group:

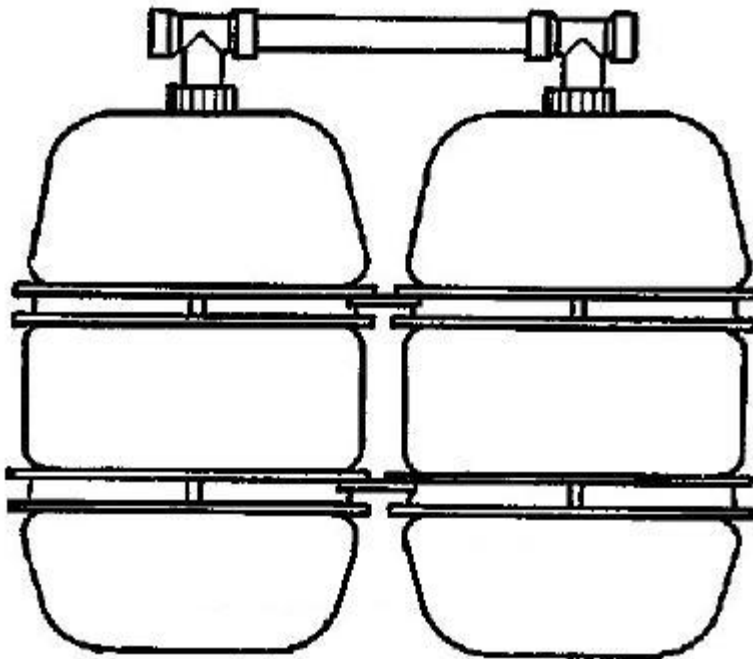
**References****Limiting references**

This place does not cover:

Large containers of variable capacity	B65D 88/005
Hoppers	B65D 88/32

B65D 88/04**spherical (B65D 88/12 takes precedence)****Definition statement***This place covers:*

Illustrative example of subject matter classified in this group:

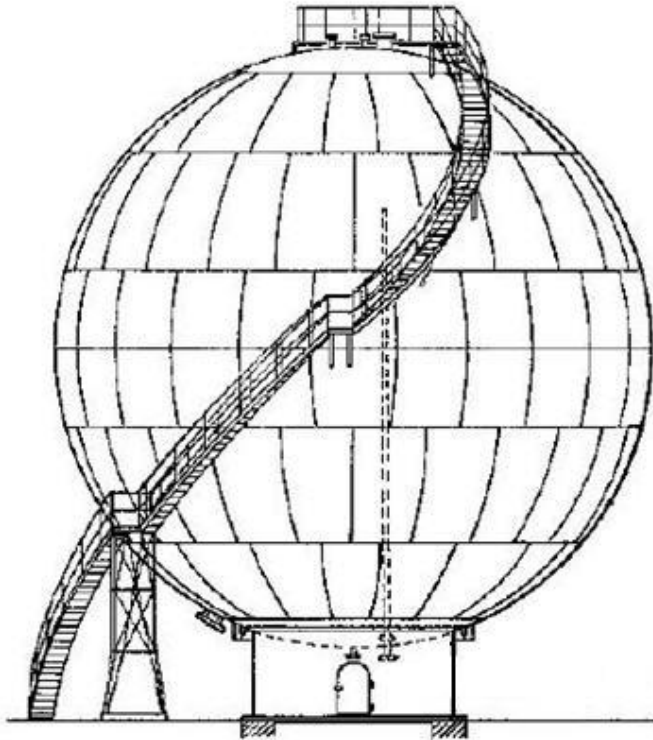
**References****Limiting references***This place does not cover:*

Specially adapted for transport (associated with vehicles)	B65D 88/12
--	----------------------------

Informative references*Attention is drawn to the following places, which may be of interest for search:*

Modular panels with features of spheroidal curvature	B65D 90/025
--	-----------------------------

B65D 88/06**cylindrical ([B65D 88/12](#) takes precedence)****Definition statement***This place covers:*

Illustrative example of subject matter classified in this group:

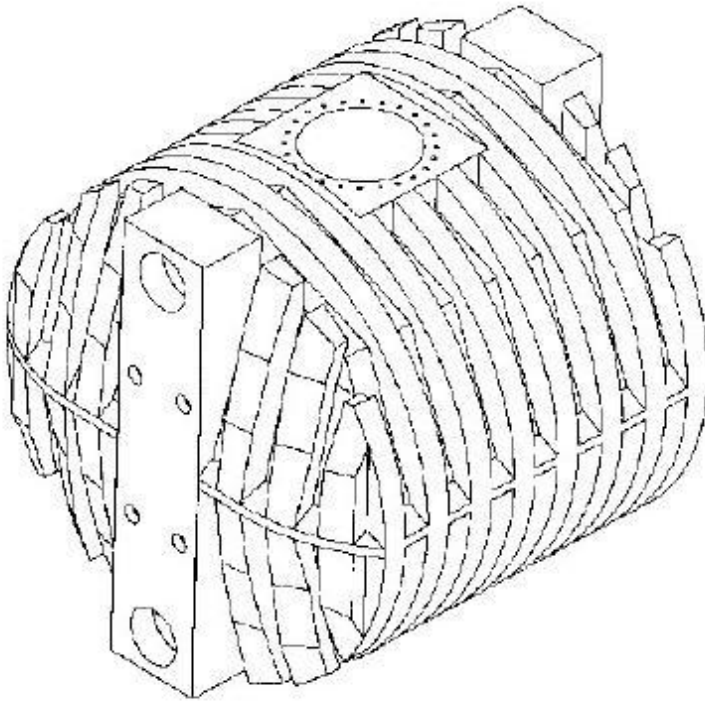
**References*****Limiting references****This place does not cover:*

Specially adapted for transport	B65D 88/12
---------------------------------	----------------------------

Informative references*Attention is drawn to the following places, which may be of interest for search:*

Modular panels with features of cylindrical curvature	B65D 90/024
Construction or assembling of bulk storage containers employing civil engineering techniques in situ or off the site	E04H 7/00

B65D 88/08**with a vertical axis****Definition statement***This place covers:*

Illustrative example of subject matter classified in this group.

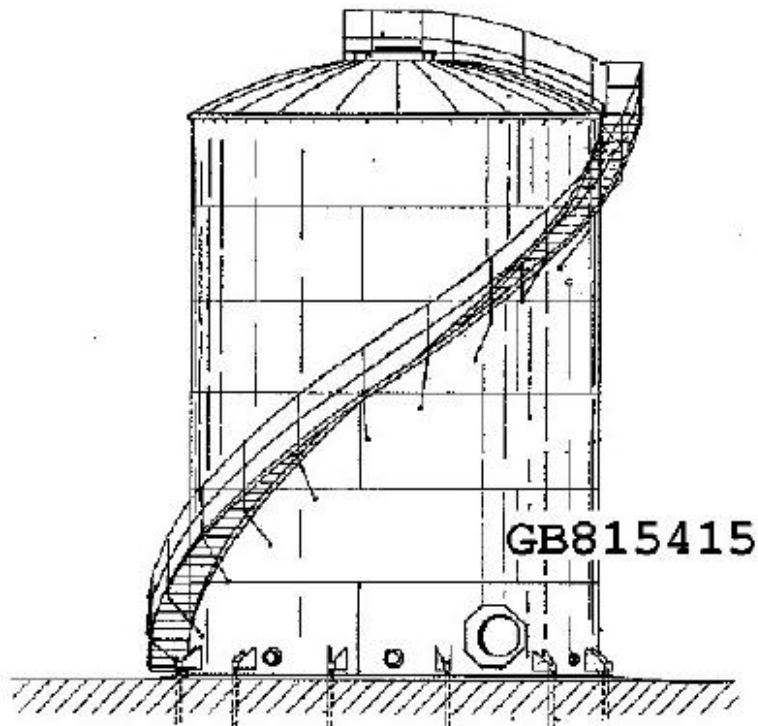
**References****Limiting references***This place does not cover:*

Mainly metal container with vertical axis	E04H 7/06
Roof constructions	E04H 7/065

Informative references*Attention is drawn to the following places, which may be of interest for search:*

Modular panels with cylindrical curvature	B65D 90/024
---	-----------------------------

B65D 88/10

parallelepipedic ([B65D 88/12](#) takes precedence)

Definition statement

This place covers:

Illustrative example of subject matter classified in this group:

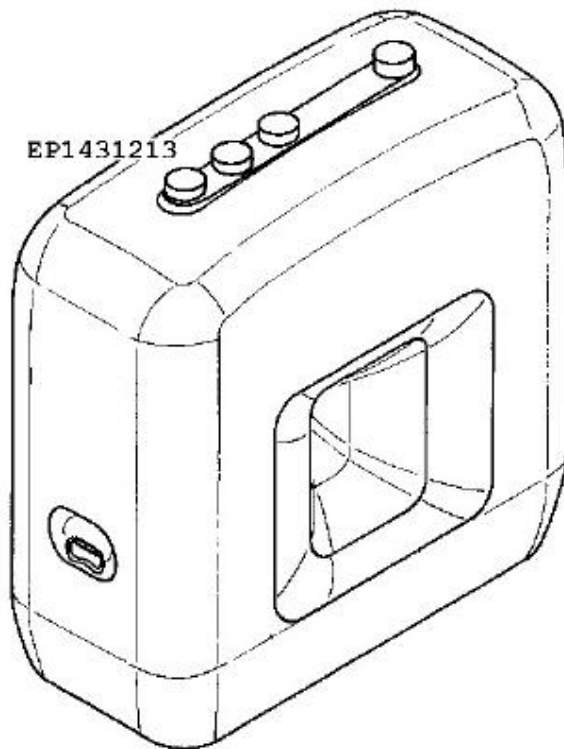
**References****Limiting references**

This place does not cover:

Specially adapted for transport	B65D 88/12
---------------------------------	----------------------------

Informative references

Attention is drawn to the following places, which may be of interest for search:

Modular panels	B65D 90/023
----------------	-----------------------------

B65D 88/12

specially adapted for transport (associated with vehicles, see the relevant subclasses of [B60](#) - [B64](#))

References**Limiting references**

This place does not cover:

Application as house or office	E04B 1/34336
--------------------------------	------------------------------

Special rules of classification

The use of available Indexing Codes is mandatory.

B65D 88/121

{ISO containers}

Definition statement

This place covers:

Illustrative example of subject matter classified in this group:

**References****Limiting references**

This place does not cover:

Corner fittings	B65D 90/0026
Doors therefore	B65D 90/008
ISO container used as house, hospital, office, etc.	E04B 1/34336

Informative references

Attention is drawn to the following places, which may be of interest for search:

ISO type containers (FTCLA)	3E070/AA26
-----------------------------	------------

B65D 88/122

{with access from above}

References**Limiting references**

This place does not cover:

Transporter frames for containers	B65D 88/129
Partial openings on manholes	B65D 90/10

B65D 88/123

{open top}

Definition statement

This place covers:

Illustrative example of subject matter classified in this group:

**References****Informative references**

Attention is drawn to the following places, which may be of interest for search:

In multiple arrangement	B65D 88/022
Transporter frames for containers	B65D 88/129

B65D 88/124**{closable top}****References*****Informative references****Attention is drawn to the following places, which may be of interest for search:*

Non-fixed roofs; Roofs with movable panels	B60J 7/00
--	---------------------------

B65D 88/125**{by flexible element, e.g. canvas}****Definition statement***This place covers:*

Illustrative example of subject matter classified in this group.

**References*****Limiting references****This place does not cover:*

Flexible closure for side walls	B65D 90/021
---------------------------------	-----------------------------

Informative references*Attention is drawn to the following places, which may be of interest for search:*

Coverings, e.g. for insulating purposes	B65D 90/06
---	----------------------------

B65D 88/126

{by rigid element, e.g. lid}

Definition statement

This place covers:

Illustrative example of subject matter classified in this group:

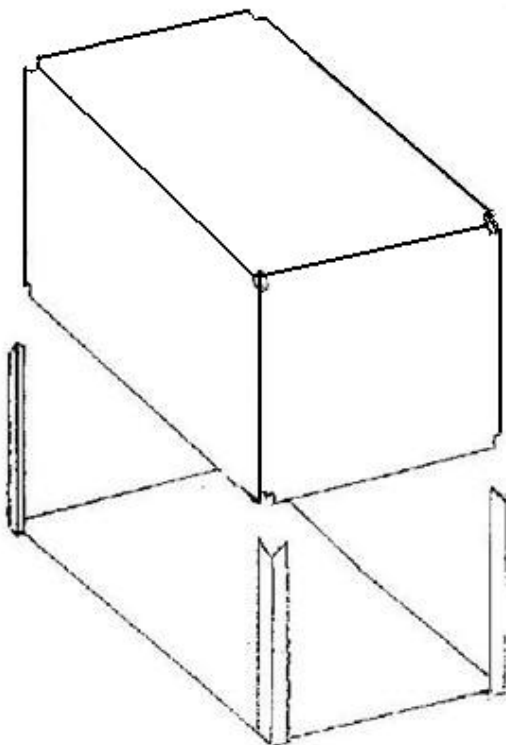
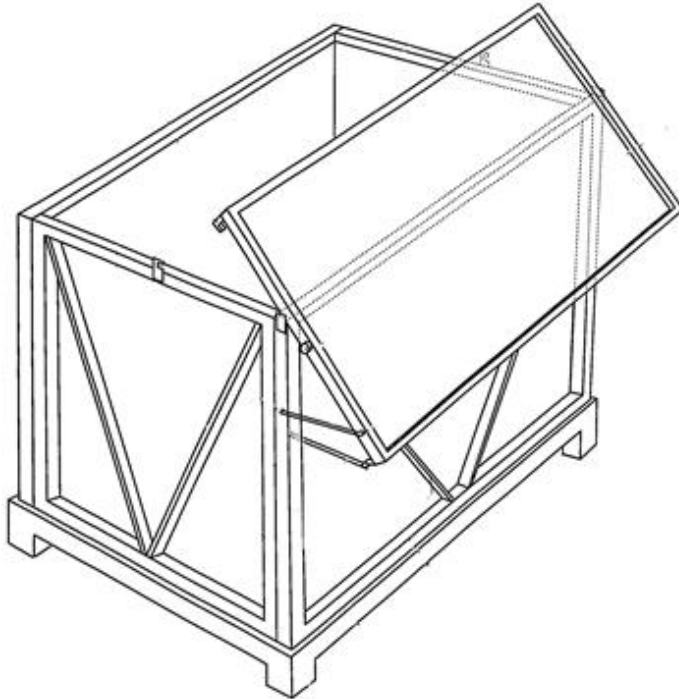

References

Limiting references

This place does not cover:

Manholes; Inspection openings; Covers therefor	B65D 90/10
Non fixed roof for vehicles	B60J 7/00

B65D 88/127

{open-sided container, i.e. having substantially the whole side free to provide access, with or without closures ([B65D 88/129](#), [B65D 90/008](#) take precedence)}

Definition statement

This place covers:

Illustrative example of subject matter classified in this group.



References

Limiting references

This place does not cover:

Some similar construction of the container	B65D 88/129
Doors for containers	B65D 90/008
Flexible closure	B65D 90/021
Doors / tarpaulin on the side of the vehicles	B60J 5/04

Informative references

Attention is drawn to the following places, which may be of interest for search:

By displacement of walls	B65D 88/58
--------------------------	----------------------------

B65D 88/128**{tank containers, i.e. containers provided with supporting devices for handling}****Definition statement***This place covers:*

Illustrative example of subject matter classified in this group:

**References****Limiting references***This place does not cover:*

Tank vehicles, accessories and construction details thereof	B60P 3/22
---	---------------------------

B65D 88/129**{Transporter frames for containers}****Definition statement***This place covers:*

Illustrative examples of subject matter classified in this group:



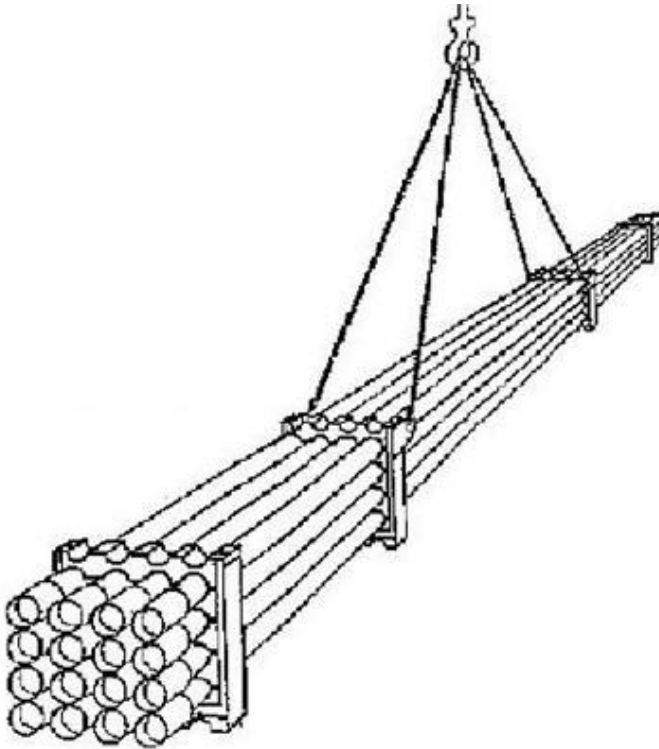

References

Limiting references

This place does not cover:

Pallets, generally of smaller size	B65D 19/00
Separate frames for pipes	B65D 85/20 , B65D 61/00
Open top container	B65D 88/123

Informative references

Attention is drawn to the following places, which may be of interest for search:

Vehicles for transporting loads specially adapted for carrying different numbers of container or containers of different sizes	B60P 1/6481
--	-----------------------------

Special rules of classification

Collapsible and or dismountable must be classified also in [B65D 88/52](#).

B65D 88/14**by air****Definition statement***This place covers:*

Illustrative examples of subject matter classified in this group:

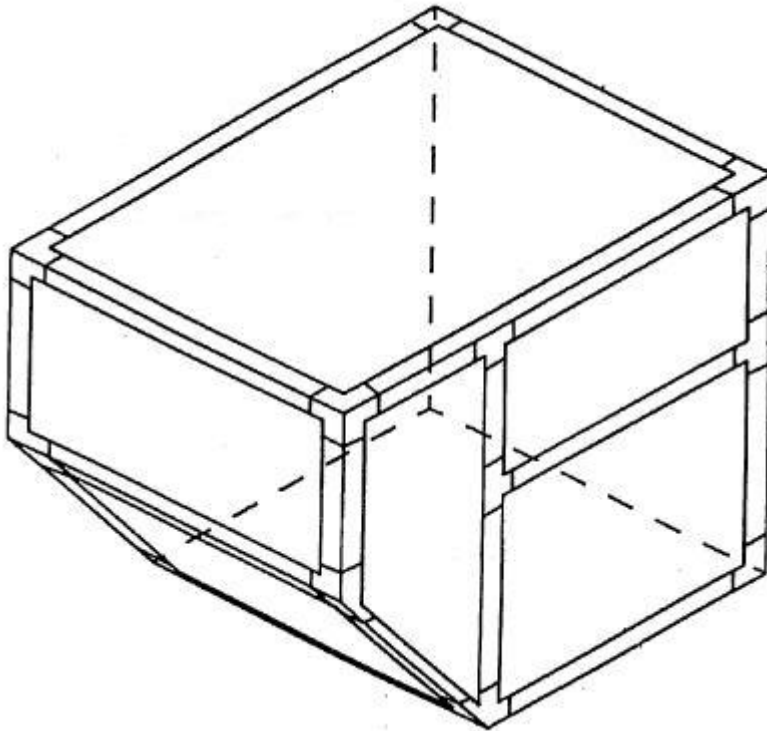
**References****Limiting references***This place does not cover:*

For blast resistant	B65D 90/325
---------------------	-----------------------------

Informative references*Attention is drawn to the following places, which may be of interest for search:*

Containers having bodies formed by interconnecting or uniting two or more rigid, or substantially rigid, components made wholly or mainly wood or substitutes therefor	B64D 9/00
--	---------------------------

B65D 88/16

flexible ([B65D 88/34](#) - [B65D 88/78](#) take precedence; hoppers [B65D 88/26](#))

References**Limiting references**

This place does not cover:

Large containers having floating covers; collapsible; characterised by means facilitating filling emptying; having means for heating, cooling, aerating or other conditioning of contents; for use underground; for use in or under water	B65D 88/34 - B65D 88/78
Flexible side walls	B65D 90/021
Flexible liner or bag inside a container	B65D 90/046

B65D 88/1612

{Flexible intermediate bulk containers [FIBC]}

Definition statement

This place covers:

Illustrative examples of subject matter classified in this group:

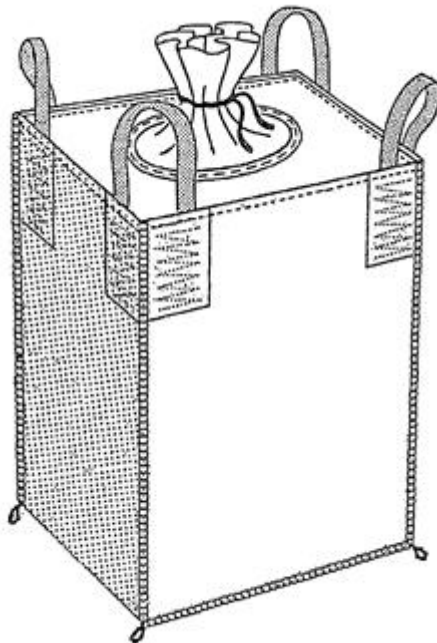
**References****Limiting references**

This place does not cover:

Flexible containers inside a rigid container of the size of a pallet	B65D 77/06 , B65D 77/061
--	---

Sacks for corpses	A61G 17/06
Holders for facilitating filling	B65B 67/12
Emptying device	B65B 69/0075
For waste big bags	B65F
Frame for transporting	B66C 1/226
Woven fabrics for sack- or bag-like articles	D03D 1/04

Special rules of classification

The use of available Indexing Codes is mandatory.

B65D 88/1618

{double-walled or with linings}

Definition statement

This place covers:

Illustrative examples of subject matter classified in this group.

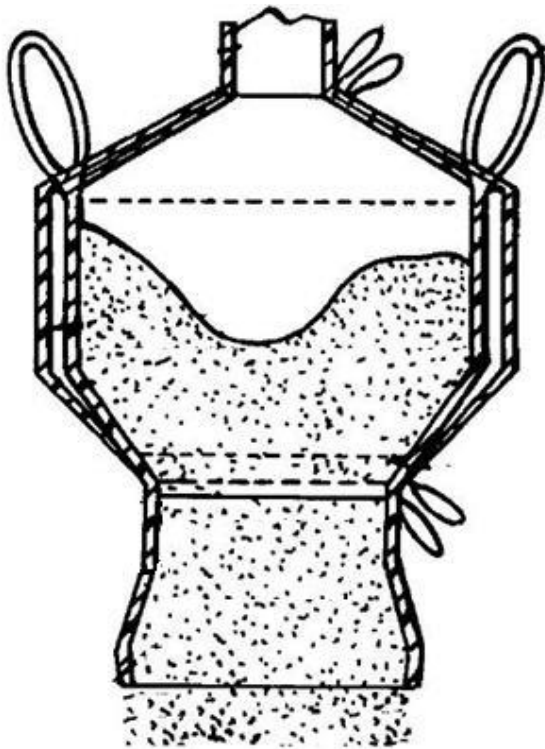

Special rules of classification

The use of available Indexing Codes is mandatory.

B65D 88/1625

{with stiffening rigid means between the walls}

Definition statement

This place covers:

Illustrative example of subject matter classified in this group:

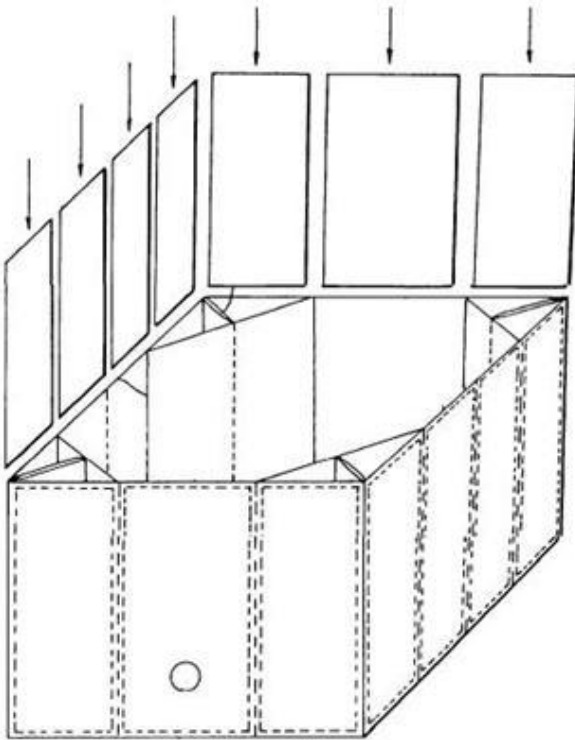

Special rules of classification

The use of available Indexing Codes is mandatory.

B65D 88/1631

{with shape keeping flexible elements}

Definition statement

This place covers:

Illustrative example of subject matter classified in this group:

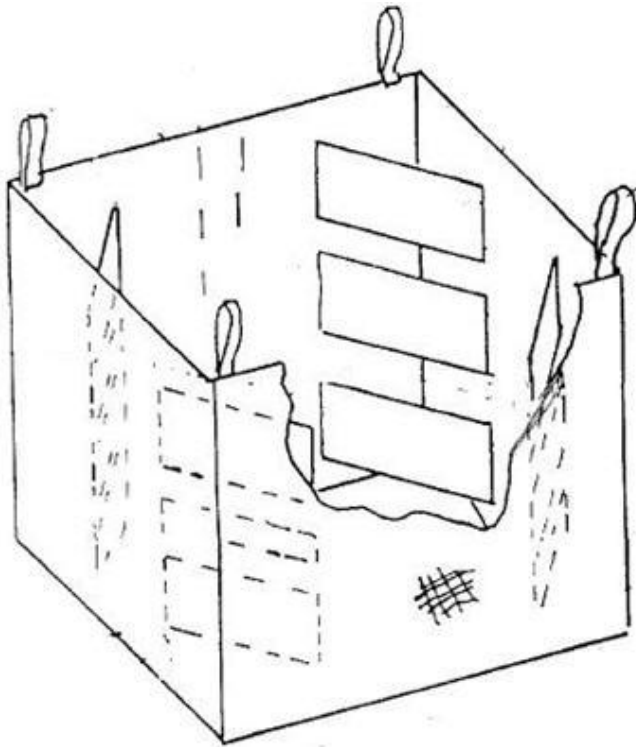

Special rules of classification

The use of available Indexing Codes is mandatory.

B65D 88/1637

{cables or straps from top to bottom}

Definition statement

This place covers:

Illustrative examples of subject matter classified in this group:

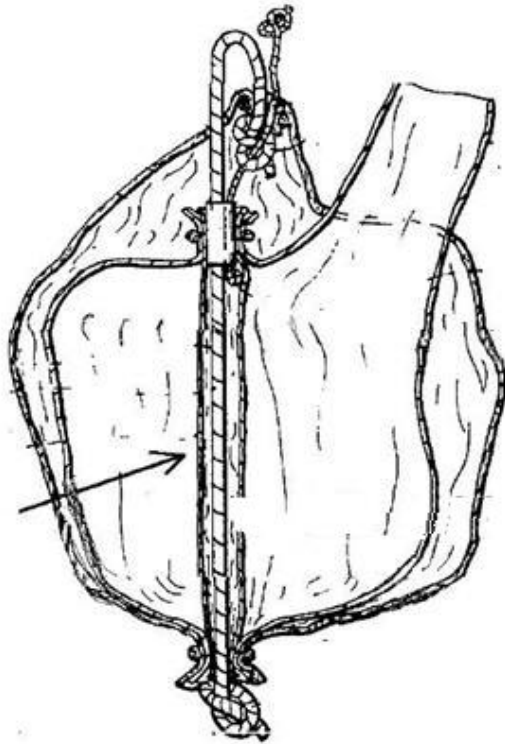

Special rules of classification

The use of available Indexing Codes is mandatory.

B65D 88/1643

{with multiple compartments}

Definition statement

This place covers:

Illustrative example of subject matter classified in this group:

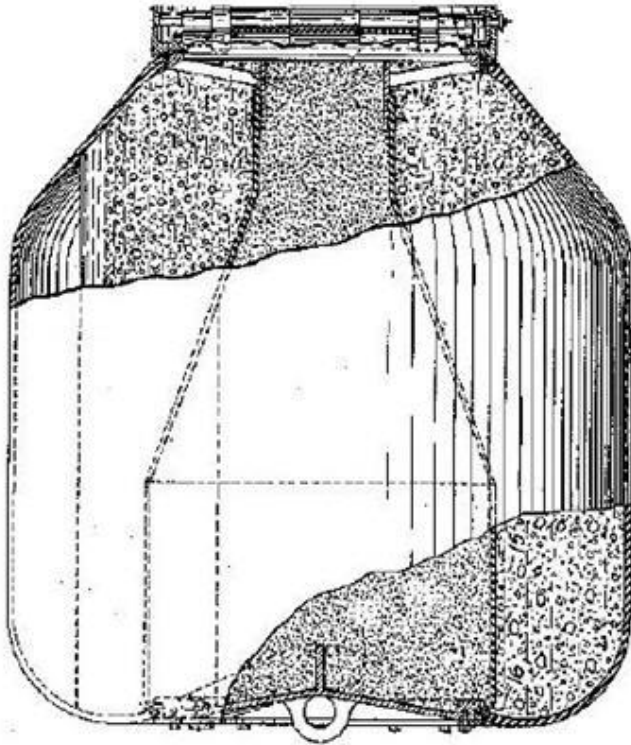

Special rules of classification

The use of available Indexing Codes is mandatory.

B65D 88/165**{with electrically conductive properties}****Definition statement***This place covers:*

Illustrative examples of subject matter classified in this group:

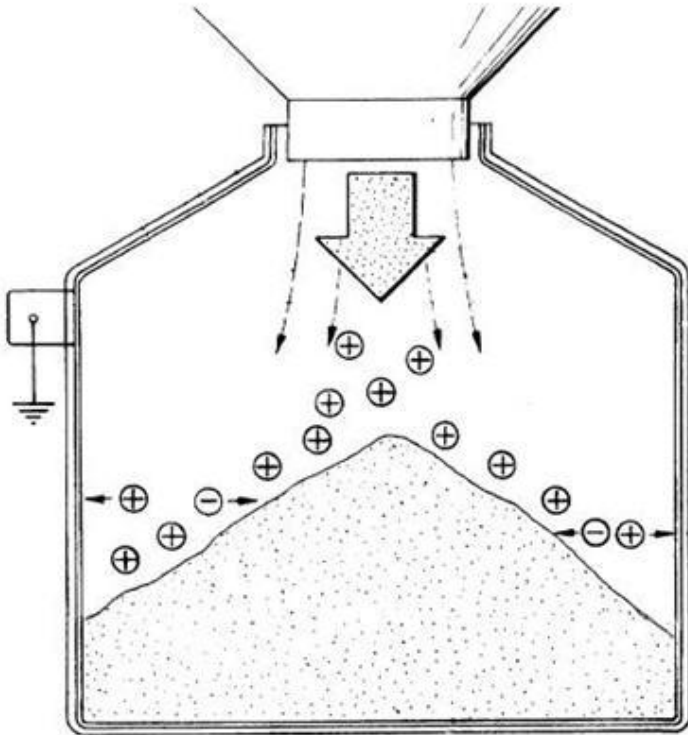
**References****Limiting references***This place does not cover:*

Anti-static for other containers	B65D 90/46
For small containers	B65D 2213/02
For taps	B67D 7/3236
Anti-static fabrics	D03D 15/533

Special rules of classification

The use of available Indexing Codes is mandatory.

B65D 88/1656

{for liquids}

Definition statement

This place covers:

Illustrative example of subject matter classified in this group:

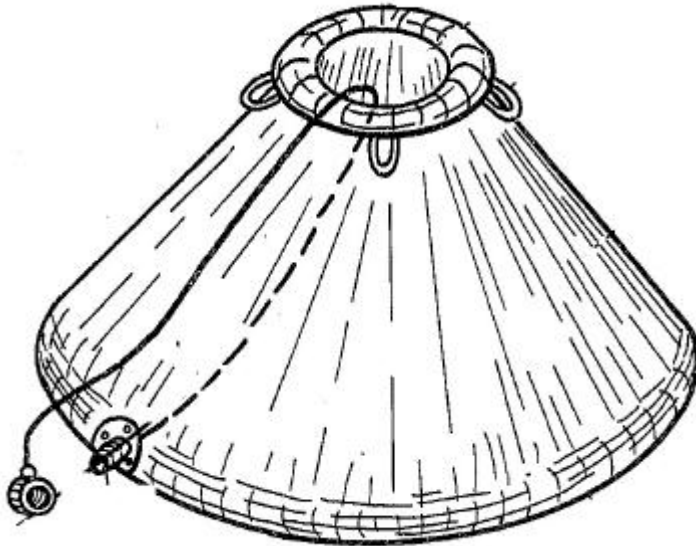

Special rules of classification

The use of available Indexing Codes is mandatory.

B65D 88/1662

{surrounded by a net}

Definition statement

This place covers:

Illustrative example of subject matter classified in this group:

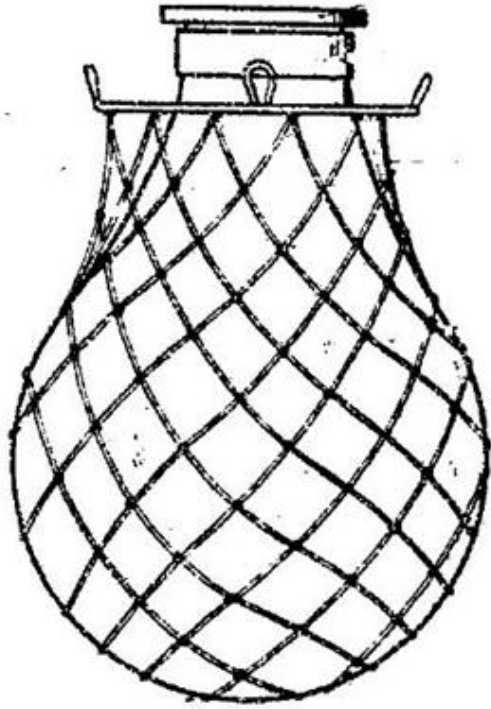

Special rules of classification

The use of available Indexing Codes is mandatory.

B65D 88/1668**{closures for top or bottom openings}****Definition statement***This place covers:*

Illustrative example of subject matter classified in this group:

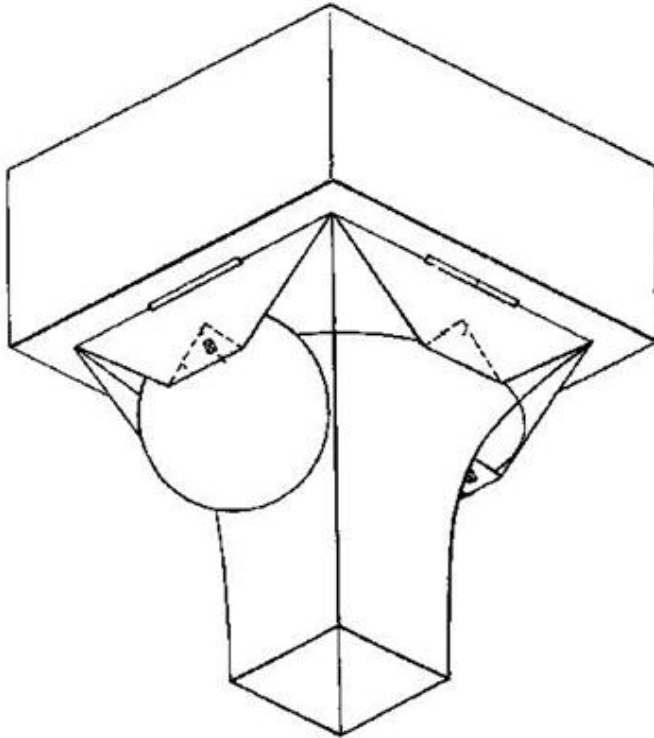
**References*****Informative references****Attention is drawn to the following places, which may be of interest for search:*

Gates or closures operating by deformation of flexible walls	B65D 90/56
Input and discharge openings (FTCLA)	3E070/WK01

Special rules of classification

The use of available Indexing Codes is mandatory.

B65D 88/1681

{Flexible, e.g. loops, or reinforcements therefor}

Definition statement

This place covers:

Illustrative example of subject matter classified in this group:

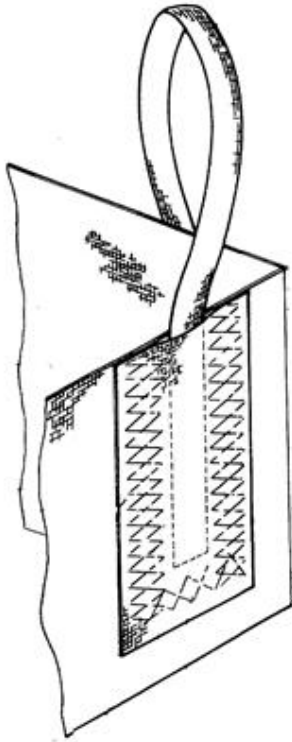

In FR2353460 the metallic ring (see red circle) connected to the flexible loop is considered a reinforcement:



Special rules of classification

The use of available Indexing Codes is mandatory.

B65D 88/1687

{specially adapted for the forks of a forklift}

Definition statement

This place covers:

Illustrative examples of subject matter classified in this group:

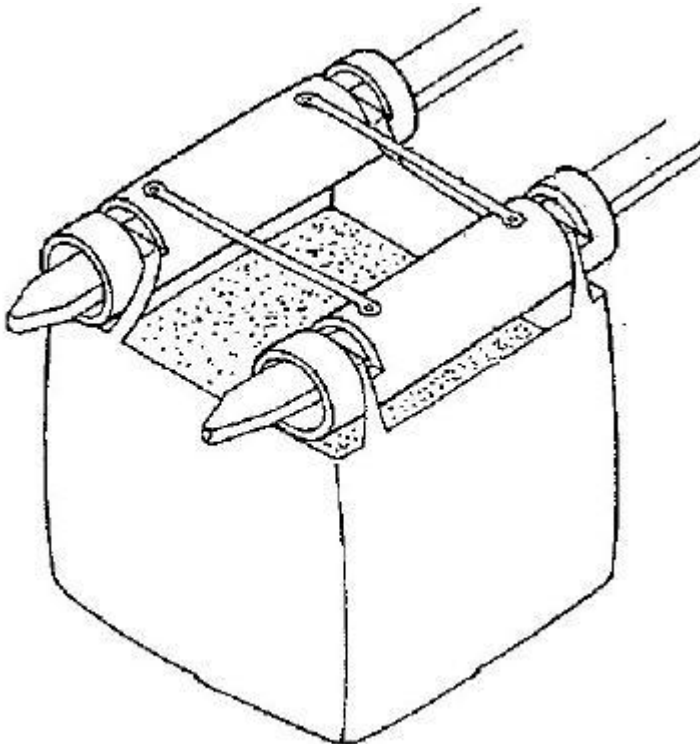
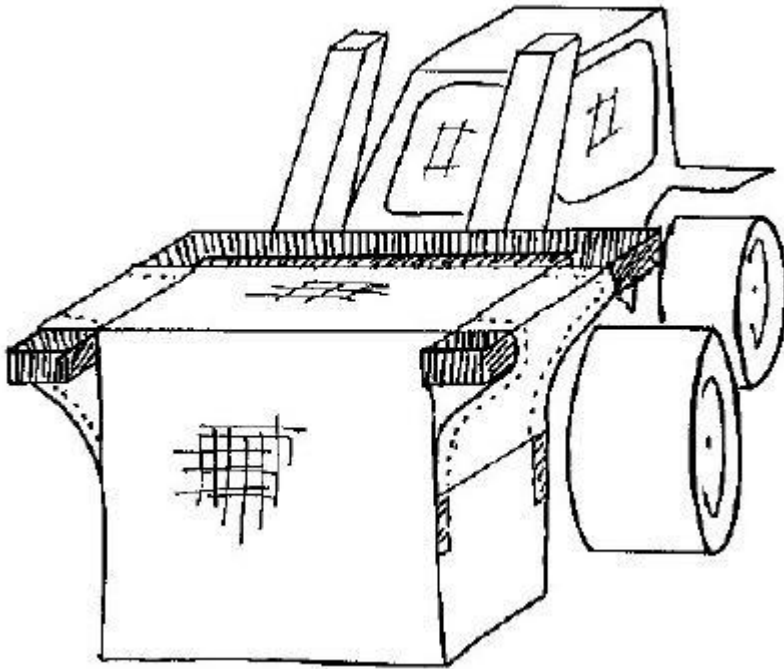

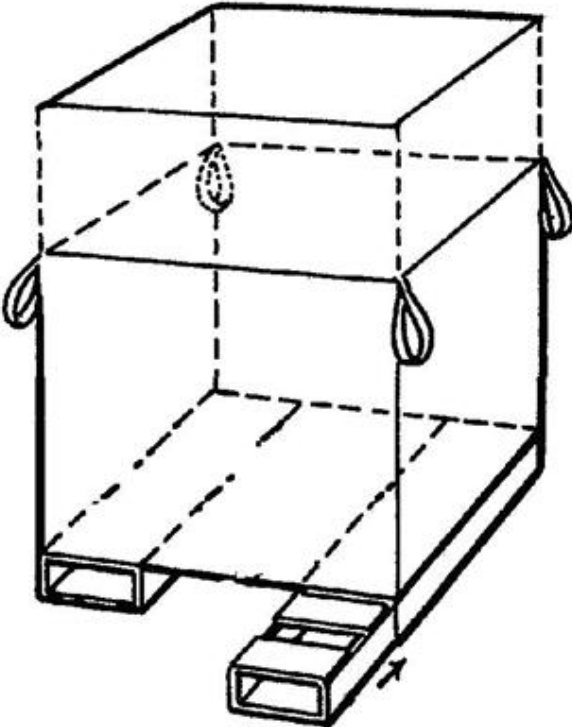

Special rules of classification

The use of available Indexing Codes is mandatory.

B65D 88/1693**{Rigid ([B65D 90/205](#) takes precedence)}****Definition statement***This place covers:*

Illustrative examples of subject matter classified in this group:

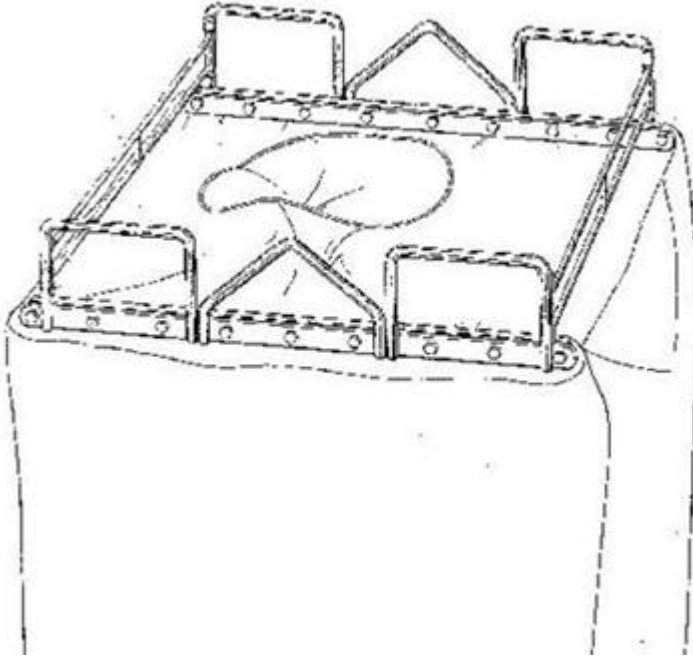
**References*****Limiting references****This place does not cover:*

Lifting fittings specially adapted for the forks of a forklift	B65D 88/1687
With rigid end-walls	B65D 88/20
Frames or nets	B65D 90/205

Special rules of classification

The use of available Indexing Codes is mandatory.

B65D 88/18

bellows-shaped ([B65D 88/22](#) takes precedence; connection of valves to inflatable elastic bodies [B60C 29/00](#))

Definition statement

This place covers:

Illustrative example of subject matter classified in this group:

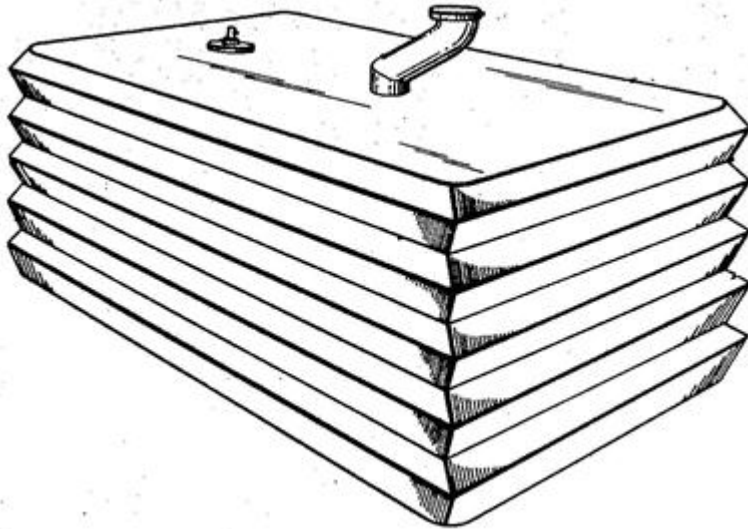
**References****Limiting references**

This place does not cover:

Specially adapted for transport (associated with vehicles)	B65D 88/22
Rigid container having flexible side walls	B65D 90/021

B65D 88/20

with rigid end-walls ([B65D 88/18](#), [B65D 88/22](#) take precedence)

References**Limiting references**

This place does not cover:

Large bellows-shaped containers	B65D 88/18
Specially adapted for transport (associated with vehicles)	B65D 88/22

Informative references

Attention is drawn to the following places, which may be of interest for search:

Rigid container having flexible side walls	B65D 90/021
Frames or nets for flexible containers	B65D 90/205

B65D 88/22

especially adapted for transport (associated with vehicles, see the relevant subclasses of [B60](#) - [B64](#))

References

Informative references

Attention is drawn to the following places, which may be of interest for search:

Frames or nets for flexible containers	B65D 90/205
--	-----------------------------

B65D 88/24

by air

Definition statement

This place covers:

Illustrative example of subject matter classified in this group:

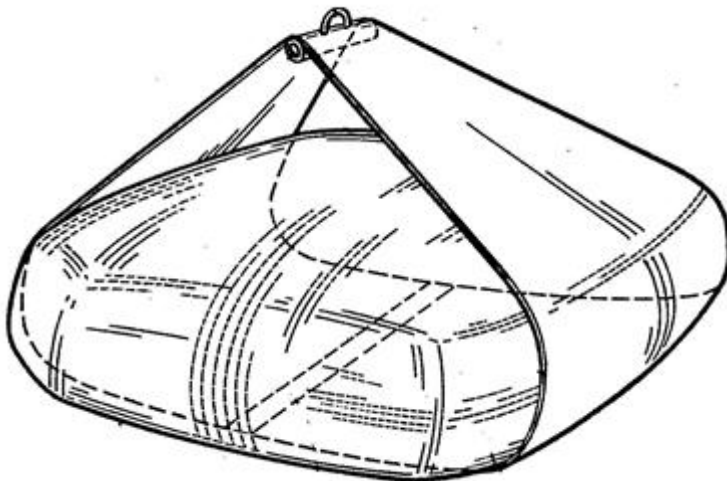

B65D 88/26

Hoppers, i.e. containers having funnel-shaped discharge sections
([B65D 88/34](#) - [B65D 88/78](#) take precedence)

Definition statement

This place covers:

Illustrative example of subject matter classified in this group:

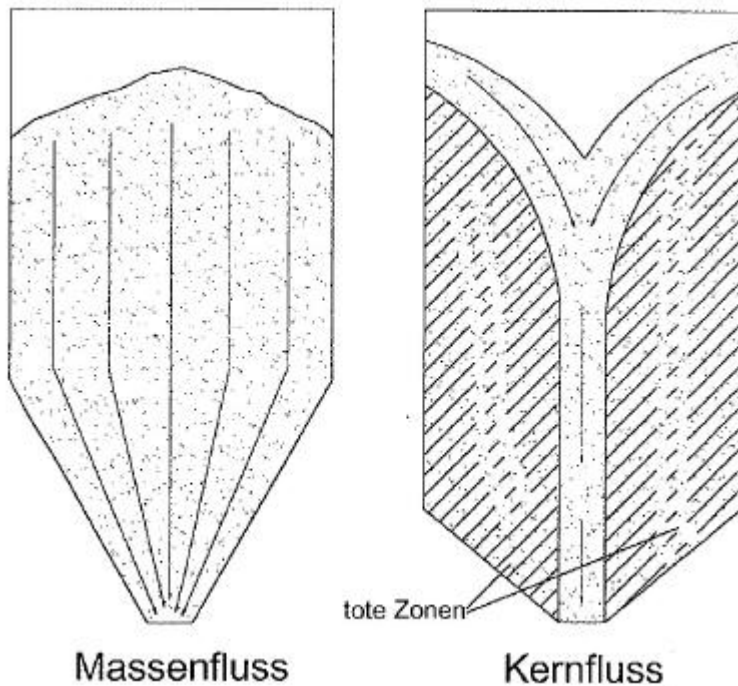
**References****Limiting references**

This place does not cover:

Silos in general	B65D 88/08
Large containers having floating covers; collapsible; characterised by means facilitating filling emptying; having means for heating, cooling, aerating or other conditioning of contents; for use underground; for use in or under water	B65D 88/34 - B65D 88/78
Closure therefor	B65D 90/54
For fertilizer	A01C 15/006
Load-transporting element having bottom discharging openings	B60P 1/56
Hopper for rail carriage	B61D 7/02
Hopper for concrete including closures	E04G 21/025

B65D 88/28

Construction or shape of discharge section

Definition statement

This place covers:

Illustrative example of subject matter classified in this group:

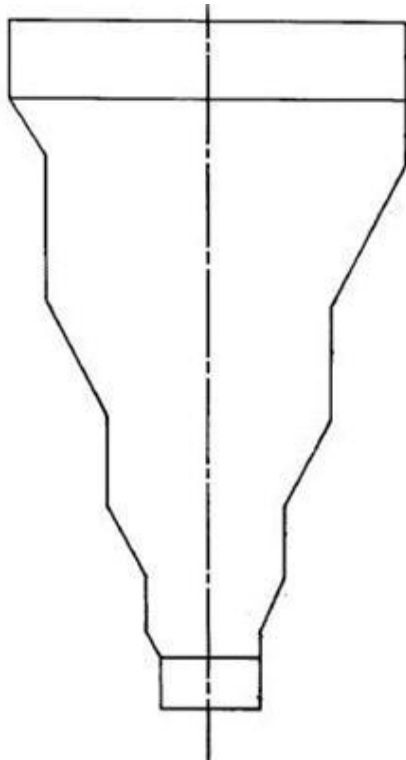

References

Informative references

Attention is drawn to the following places, which may be of interest for search:

Preventing bridge formation	B65D 88/64
-----------------------------	----------------------------

B65D 88/30

especially adapted to facilitate transportation from one utilisation site to another (collapsible hoppers [B65D 88/52](#))

Definition statement

This place covers:

Illustrative example of subject matter classified in this group:

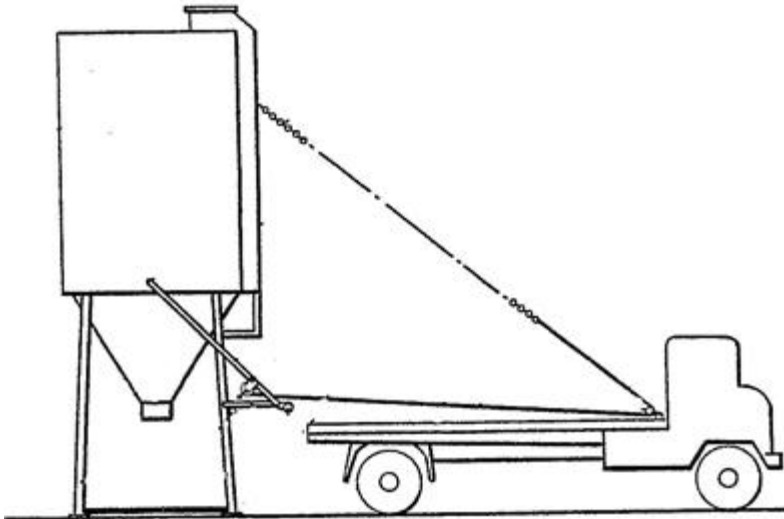
**References****Informative references**

Attention is drawn to the following places, which may be of interest for search:

Vehicles predominantly for transporting loads and modified to facilitate loading, consolidating the load, or unloading, fitted with articulated beams for longitudinal displacement of the container	B60P 1/6463
--	-----------------------------

B65D 88/32**in multiple arrangement****Definition statement***This place covers:*

Illustrative examples of subject matter classified in this group:

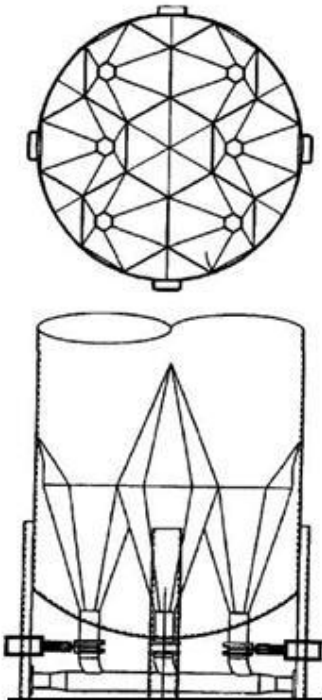
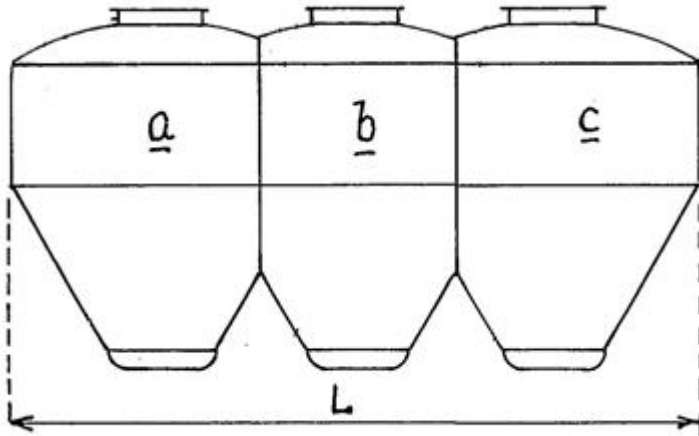

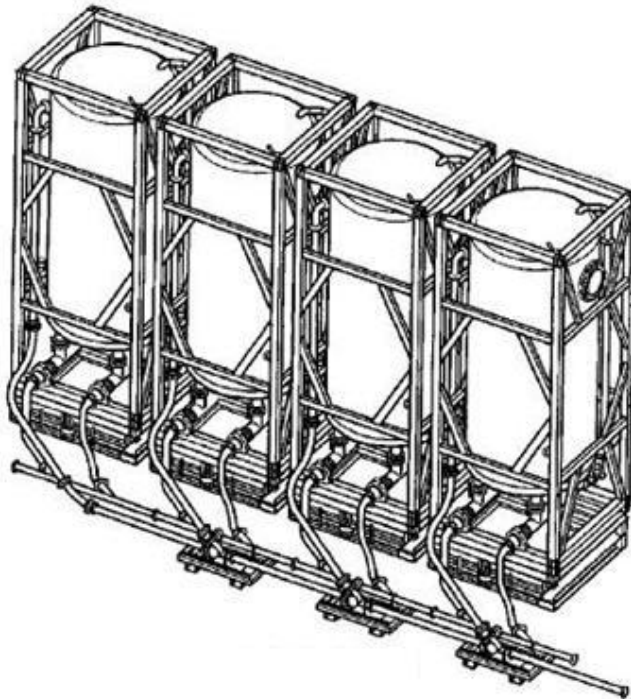

References

Limiting references

This place does not cover:

General construction of the hopper and of the silo container for gates	B65D 90/60 , B65D 90/64 , B65D 2590/547
--	--

B65D 88/34

having floating covers, e.g. floating roofs or blankets (venting means [B65D 90/34](#))

Definition statement

This place covers:

Illustrative example of subject matter classified in this group:

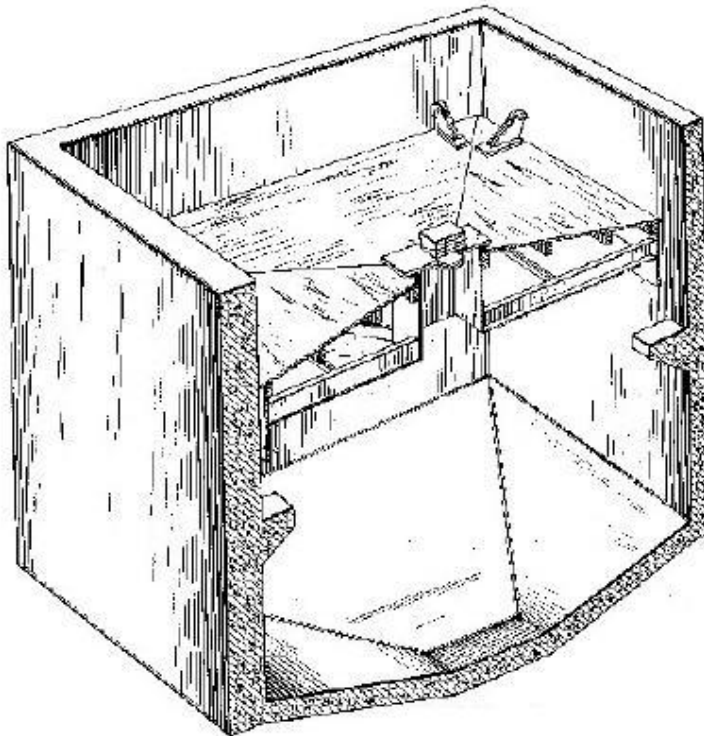
**References****Limiting references**

This place does not cover:

Having floating covers	B65D 88/34
Coverings, roofs or other structures for covering manure storage places	A01C 3/028
Preventing evaporation or oxidation of non-metallic liquids by applying a floating layer	B01J 19/16
Covering of solid waste dumping sites	B09B 1/004
For treatment of water, waste water	C02F 3/00
With means for collecting fermentation gases, e.g. methane	C12M 1/107 , C02F 11/04
Coverings for baths, e.g. swimming pools,	E04H 4/06 , E04H 4/08 , E04H 4/10

Informative references

Attention is drawn to the following places, which may be of interest for search:

Means for reducing the vapour space or for reducing the formation	B65D 90/38
---	----------------------------

Buildings for parking cars, rolling stock, aircraft, vessels or like vehicles	E04H 6/00
General characteristics (FTCLA)	3E070/WB00
Fixtures, e.g. seals (FTCLA)	3E070/WC00
Accessories (FTCLA)	3E070/WD00

B65D 88/36

with relatively movable sections

Definition statement

This place covers:

Illustrative example of subject matter classified in this group:

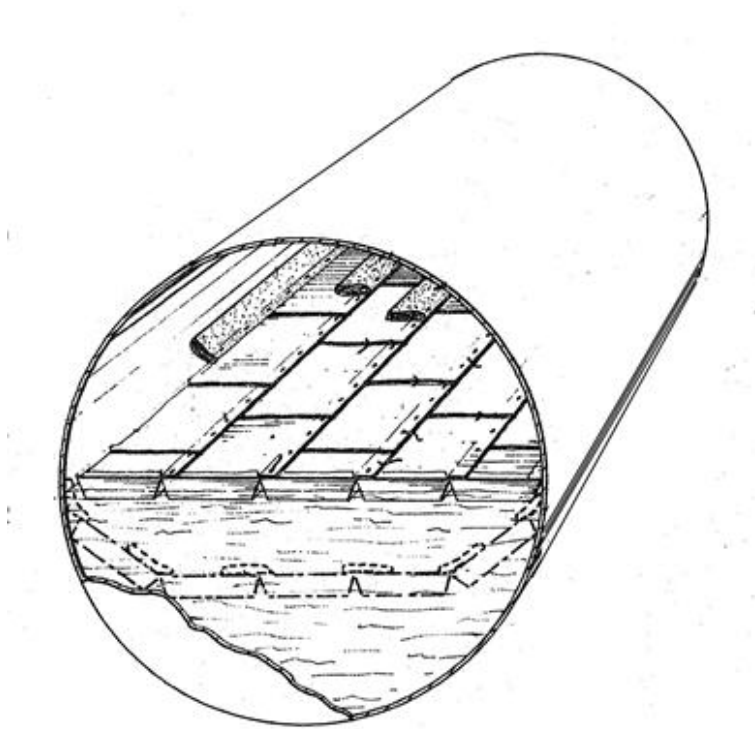

References

Limiting references

This place does not cover:

Discrete elements disposed side by side	B65D 90/42 , E04H 4/08 , A01C 3/028
---	--

B65D 88/38

with surface water receiver, e.g. drain

Definition statement

This place covers:

Illustrative example of subject matter classified in this group:

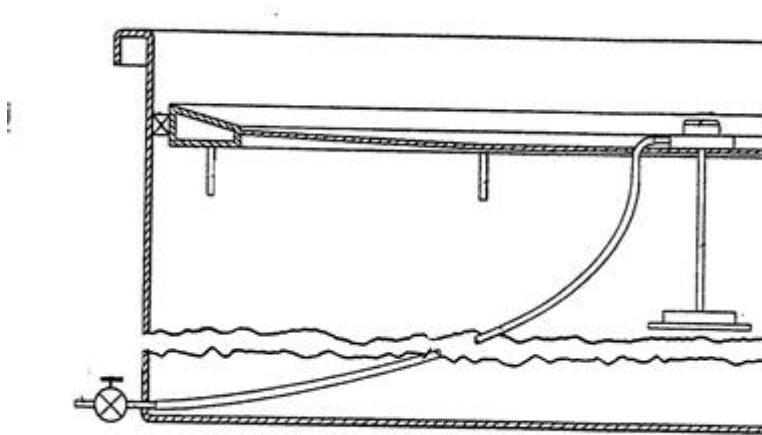
**B65D 88/40**

with support for a ground cover

Definition statement

This place covers:

Illustrative example of subject matter classified in this group:

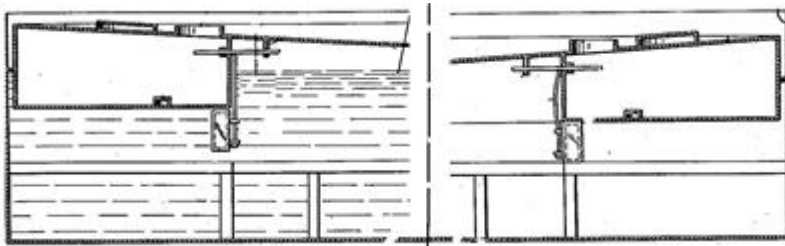
**B65D 88/42**

with sealing means between cover rim and receptacle

References**Informative references**

Attention is drawn to the following places, which may be of interest for search:

Seals (FTCLA)	3E070/WC00
---------------	------------

B65D 88/46

with mechanical means acting on the seal

Definition statement

This place covers:

Illustrative example of subject matter classified in this group:

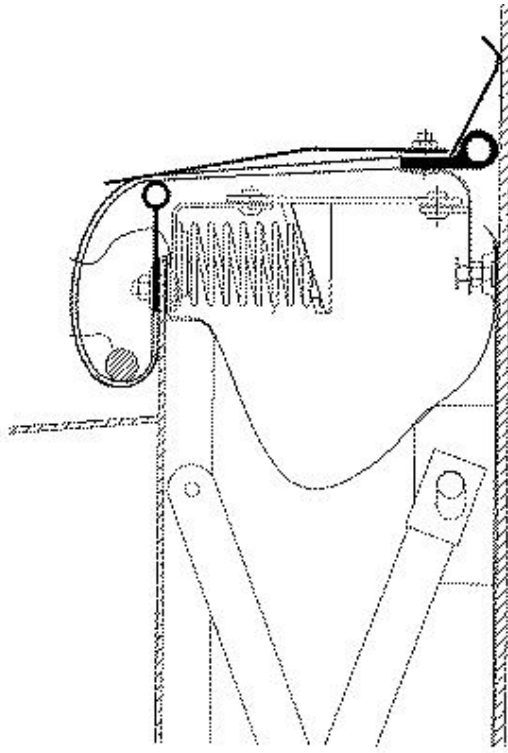

B65D 88/48

with fluid means acting on the seal

Definition statement

This place covers:

Illustrative example of subject matter classified in this group:

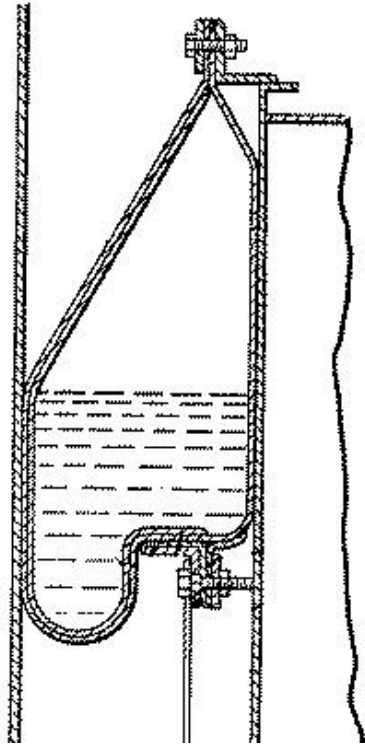

B65D 88/50

with resilient foam or stuffed seal

Definition statement

This place covers:

Illustrative example of subject matter classified in this group:

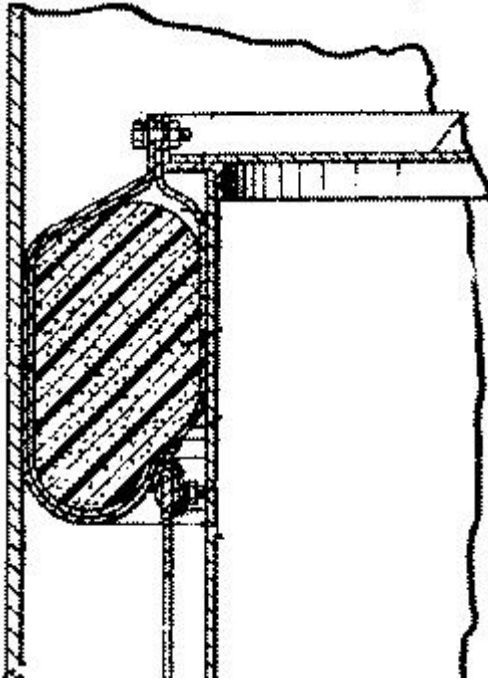

B65D 88/52

collapsible, i.e. with walls hinged together or detachably connected

Definition statement

This place covers:

Illustrative example of subject matter classified in this group:

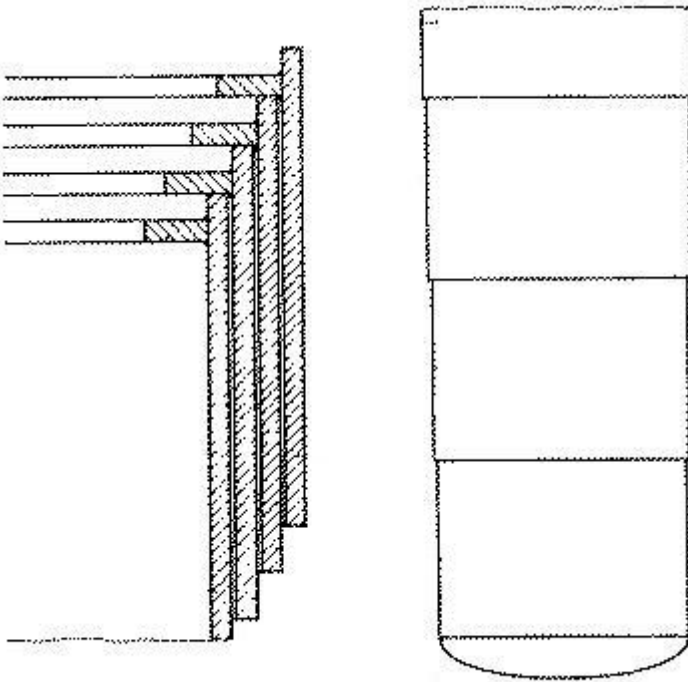
**References****Limiting references**

This place does not cover:

Variable capacity	B65D 88/005
Also telescopically collapsing container (see figure)	B65D 88/32
Modular walls	B65D 90/023
For container used as house, hospital, office etc.	E04B 1/3445

B65D 88/522

{all side walls hingedly connected to each other or to another component of the container}

Definition statement

This place covers:

Illustrative example of subject matter classified in this group:

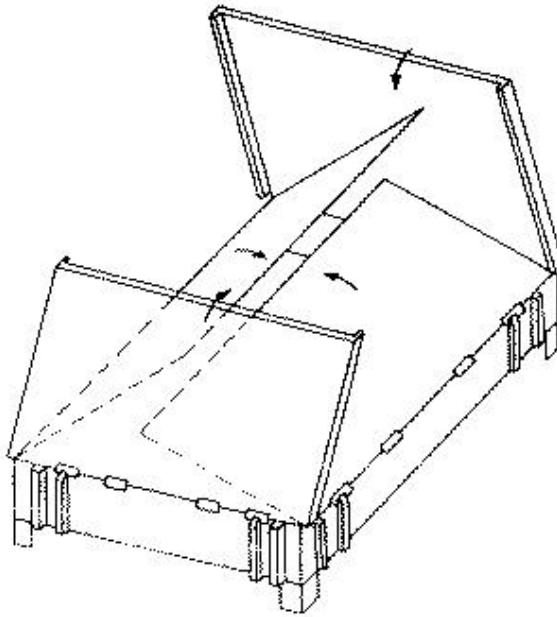

B65D 88/524

{and one or more side walls being foldable along an additional median line}

Definition statement

This place covers:

Illustrative example of subject matter classified in this group:

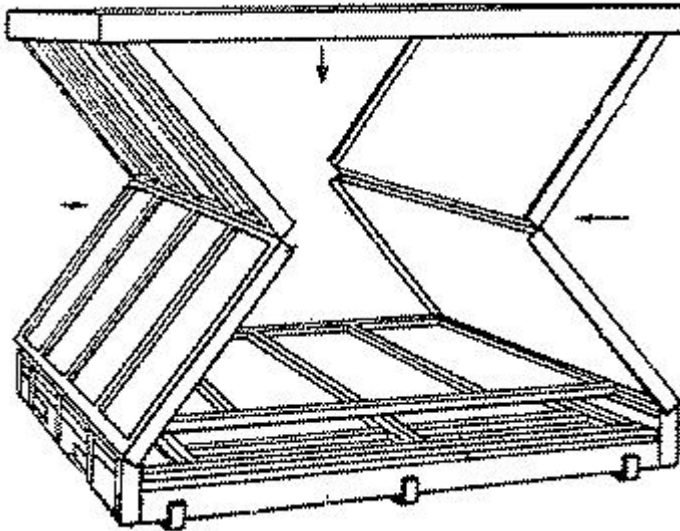

B65D 88/526

{with detachable side walls}

Definition statement

This place covers:

Illustrative example of subject matter classified in this group:

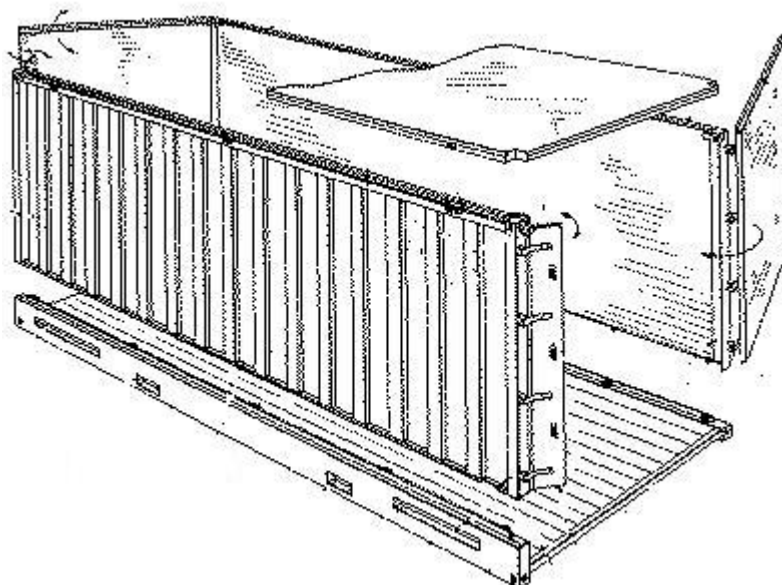

B65D 88/528

{all side walls detached from each other to collapse the container}

Definition statement

This place covers:

Illustrative example of subject matter classified in this group:

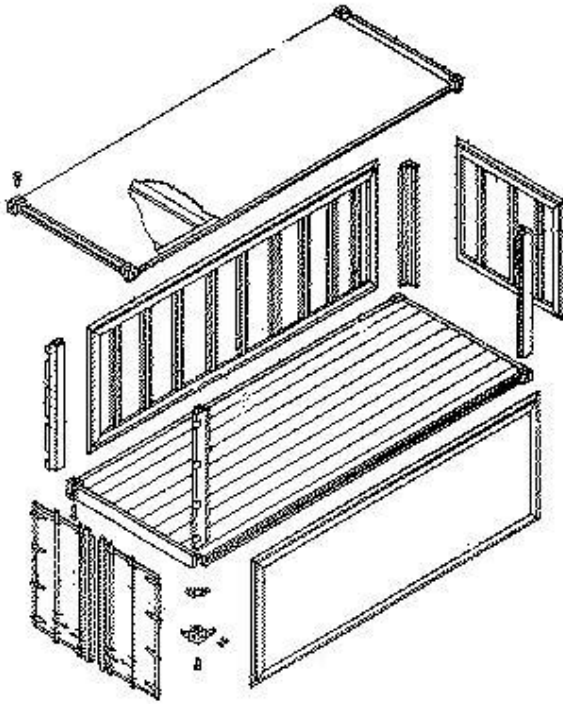
**References****Informative references**

Attention is drawn to the following places, which may be of interest for search:

Wall construction	B65D 90/023
-------------------	-----------------------------

B65D 88/54

characterised by means facilitating filling or emptying ({filling or emptying features for flexible large containers [B65B 69/0075](#); } construction or shape of discharge section of hoppers [B65D 88/28](#); gates or closures [B65D 90/54](#); filling or emptying bunkers, hoppers, or like containers [B65G 65/30](#))

References**Limiting references**

This place does not cover:

By cleaning the container inside	B08B 9/0933
Heating or cooling articles or materials to facilitate packaging	B65B 63/08 , B65B 69/0066

Special rules of classification

The use of available Indexing Codes is mandatory.

B65D 88/542

{Ramps forming part of the container (ramps per se [B65G 69/28](#); for ambulances [A61G 3/061](#); for vehicles in general [B60P 1/43](#))}

Definition statement

This place covers:

Illustrative example of subject matter classified in this group:

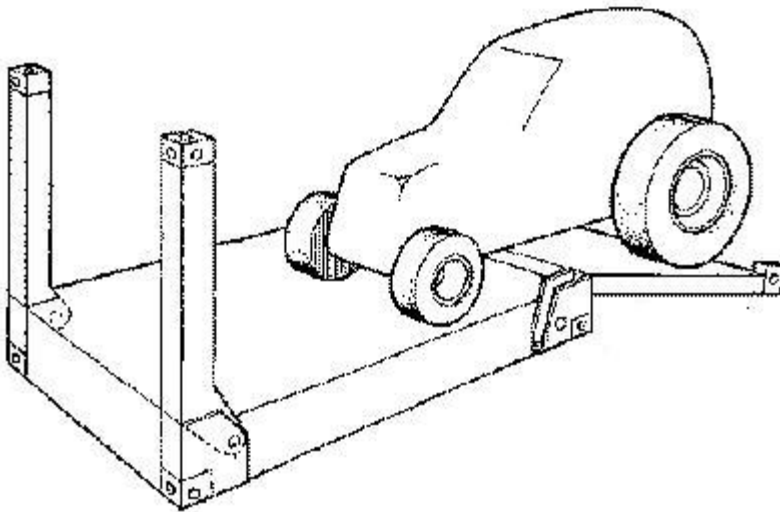

References

Informative references

Attention is drawn to the following places, which may be of interest for search:

For vehicles in general	B60P 1/43
Ramps per se	B65G 69/28

Special rules of classification

The use of available Indexing Codes is mandatory.

B65D 88/544

{for filling from below}

Definition statement

This place covers:

Illustrative example of subject matter classified in this group:

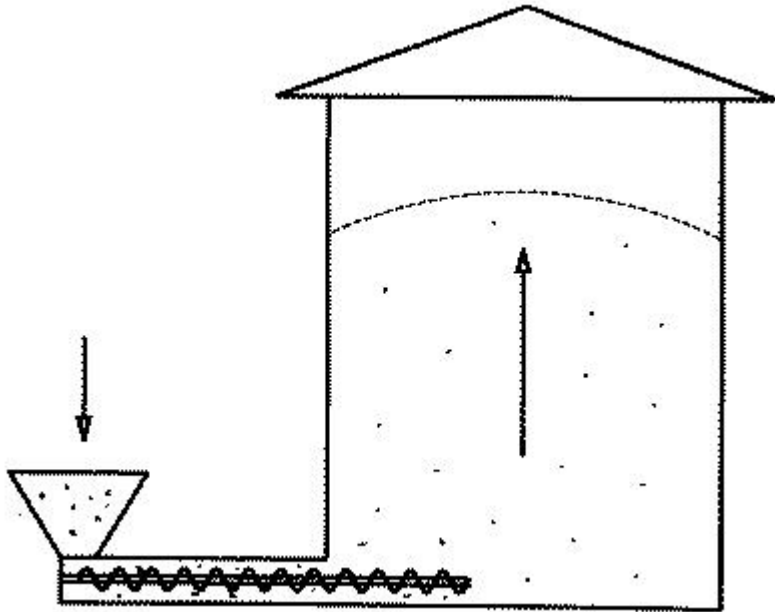

Special rules of classification

The use of available Indexing Codes is mandatory.

B65D 88/546

{Devices for loading or unloading and forming part of the container, e.g. rollers, conveyors (loading or unloading vehicles [B65G 67/20](#))}

Definition statement

This place covers:

Illustrative example of subject matter classified in this group:

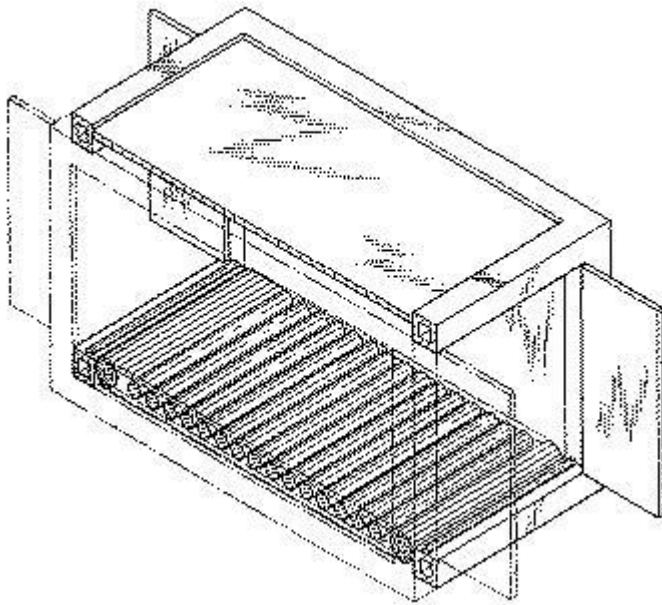

References

Informative references

Attention is drawn to the following places, which may be of interest for search:

Of internal walls	B65D 88/60
-------------------	----------------------------

Special rules of classification

The use of available Indexing Codes is mandatory.

B65D 88/548

{by pneumatic means ([B65D 88/72](#) takes precedence)}

Definition statement

This place covers:

Illustrative example of subject matter classified in this group:

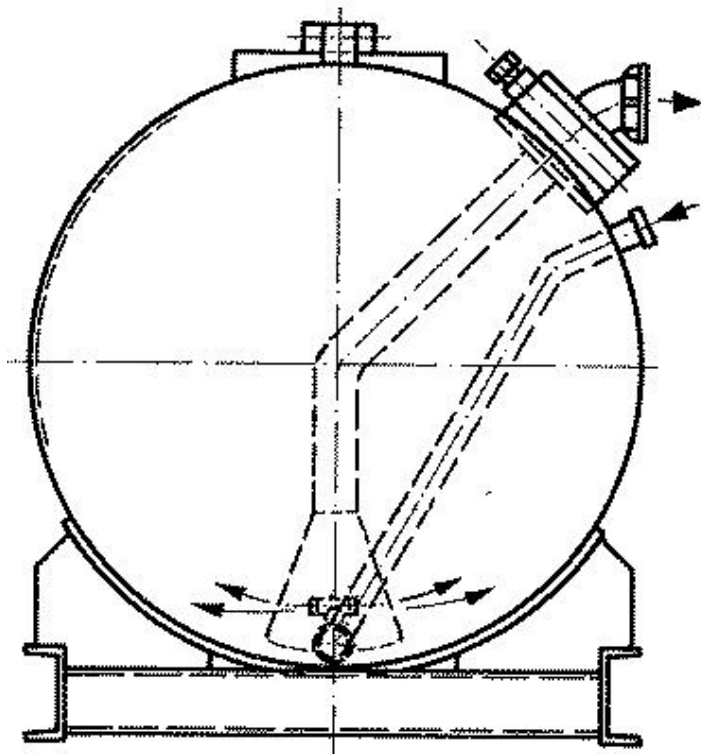
**References****Limiting references**

This place does not cover:

Fluidising devices	B65D 88/72
--------------------	----------------------------

Informative references

Attention is drawn to the following places, which may be of interest for search:

Conveying materials in bulk through troughs, pipes, or tubes by floating the materials, or by flows of gas, liquid, or foam	B65G 53/00
---	----------------------------

Special rules of classification

The use of available Indexing Codes is mandatory.

B65D 88/56**by tilting****Definition statement***This place covers:*

Illustrative example of subject matter classified in this group:

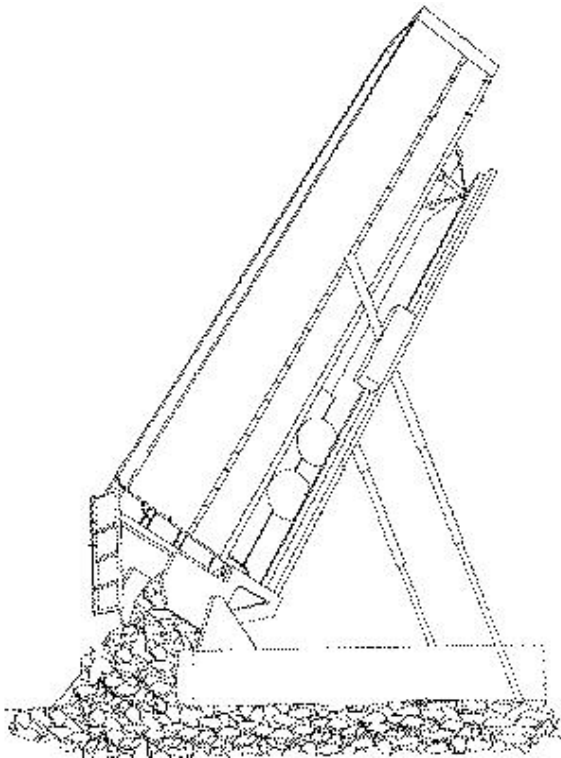
**References****Limiting references***This place does not cover:*

Tipping body constructions, elements of tipping devices, loading buckets	B60P 1/28
Tipping wagons	B61D 9/00
Devices for tilting and emptying of containers	B65G 65/23
Lifting of container	B66C

Special rules of classification

The use of available Indexing Codes is mandatory.

B65D 88/58

by displacement of walls

Definition statement

This place covers:

Illustrative example of subject matter classified in this group:

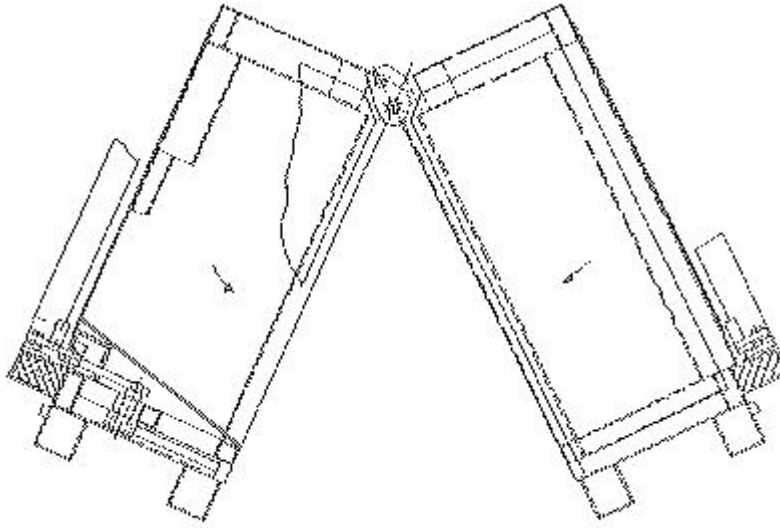

References

Limiting references

This place does not cover:

Side walls opening towards the outside and bottom opening	B65D 90/623
---	-----------------------------

Special rules of classification

The use of available Indexing Codes is mandatory.

B65D 88/60

of internal walls

Definition statement

This place covers:

Illustrative example of subject matter classified in this group:

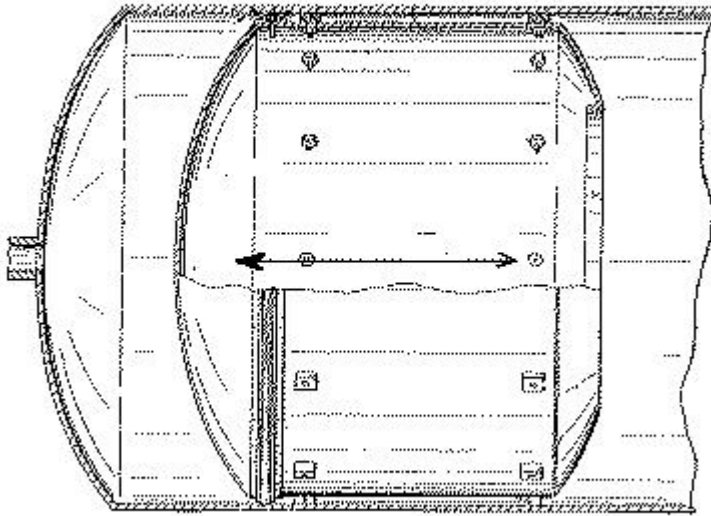

References

Limiting references

This place does not cover:

Charge and discharge of vehicles with pusher plates	B60P 1/006
Plates fixed to endless chains or belts	B60P 1/365
Sealing with the container	F16J 15/00 , B65D 88/42

Special rules of classification

The use of available Indexing Codes is mandatory.

B65D 88/62

the walls being deformable

Definition statement

This place covers:

Illustrative example of subject matter classified in this group:

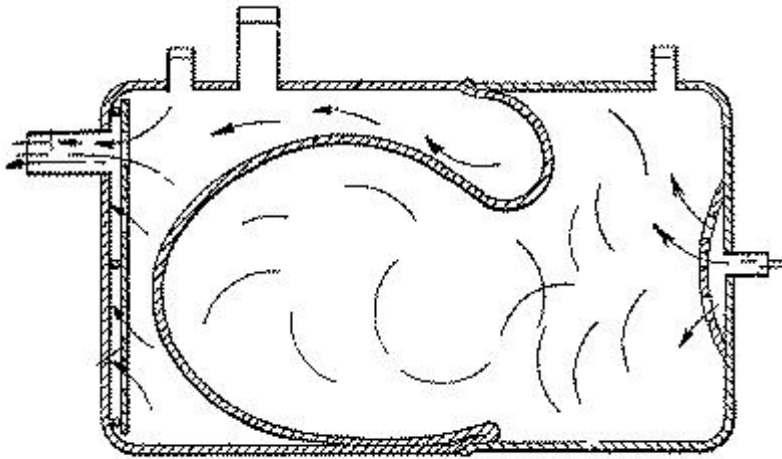
**References****Informative references**

Attention is drawn to the following places, which may be of interest for search:

For transferring liquids other than fuel or lubricant	B67D 7/02
For transferring fuels, lubricants, or mixture thereof	B67D 7/04

Special rules of classification

The use of available Indexing Codes is mandatory.

B65D 88/64

preventing bridge formation

Definition statement

This place covers:

Illustrative example of subject matter classified in this group:

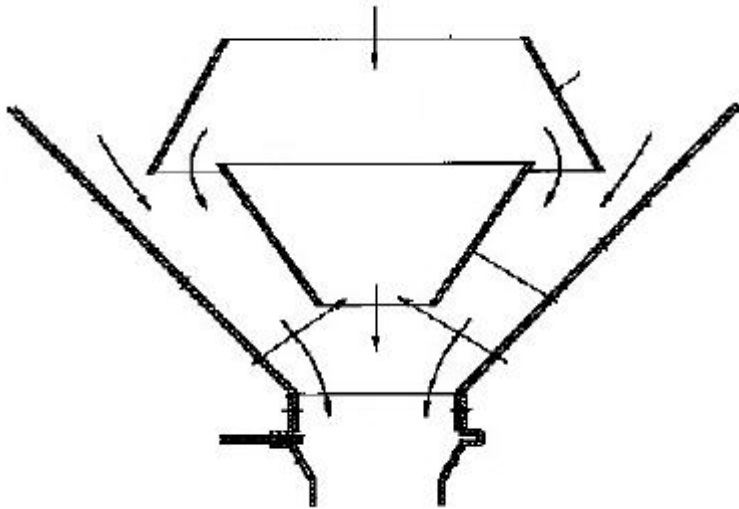

References

Informative references

Attention is drawn to the following places, which may be of interest for search:

Construction or shape of discharge section	B65D 88/28
--	----------------------------

Special rules of classification

The use of available Indexing Codes is mandatory.

B65D 88/66

using vibrating or knocking devices

Definition statement

This place covers:

Illustrative example of subject matter classified in this group:

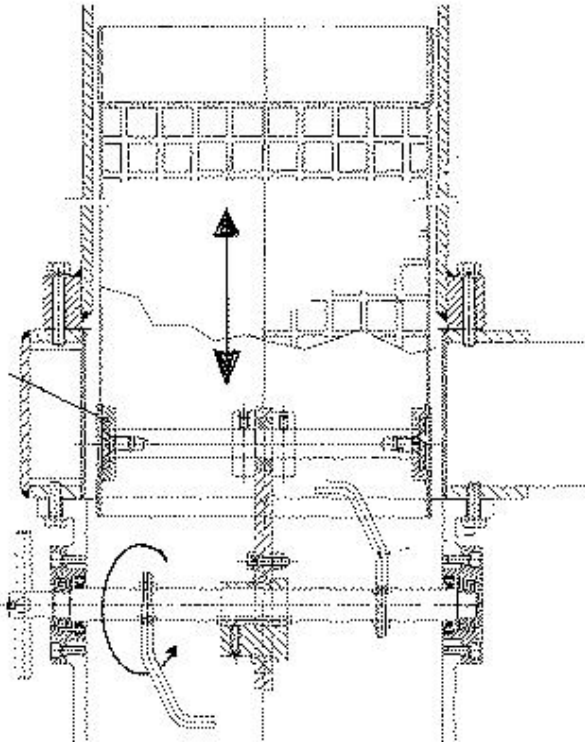
**References****Limiting references**

This place does not cover:

Preventing bridge formation using fluid jets	B65D 88/70
--	----------------------------

Informative references

Attention is drawn to the following places, which may be of interest for search:

Vibrating or knocking devices can be similar to the one in	B65D 88/70 , B06B 1/183
Mechanisms that move operating members reciprocatingly (FTCLA)	5D107/EE01

B65D 88/665

{using a resonator, e.g. supersonic generator}

Definition statement

This place covers:

Illustrative example of subject matter classified in this group:

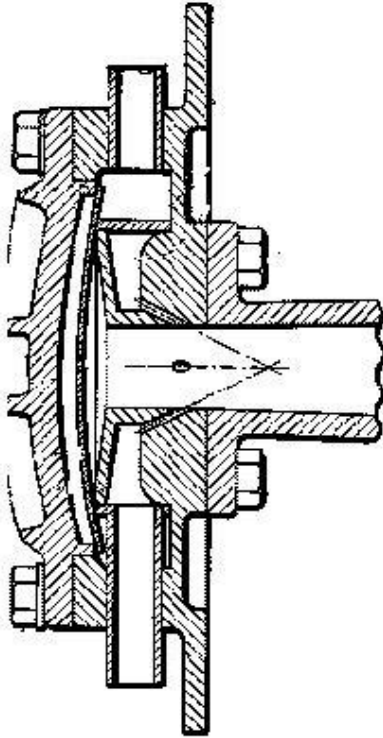

References

Informative references

Attention is drawn to the following places, which may be of interest for search:

Methods or apparatus for generating mechanical vibrations of infrasonic, sonic, or ultrasonic frequency

B06B 1/00

B65D 88/68

using rotating devices

Definition statement

This place covers:

Illustrative example of subject matter classified in this group:

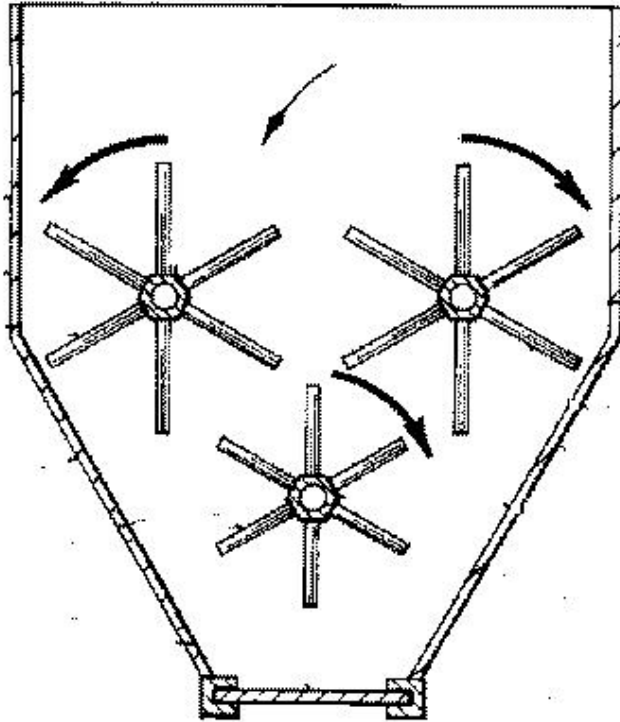
**B65D 88/70**

using fluid jets ([B65D 88/72](#) takes precedence)

References**Informative references**

Attention is drawn to the following places, which may be of interest for search:

Fluidising devices	B65D 88/72
Parts, e.g. diffusion elements; Accessories	B01F 33/409

B65D 88/703

{Air blowing devices, i.e. devices for the sudden introduction of compressed air into the container}

Definition statement

This place covers:

Illustrative examples of subject matter classified in this group:

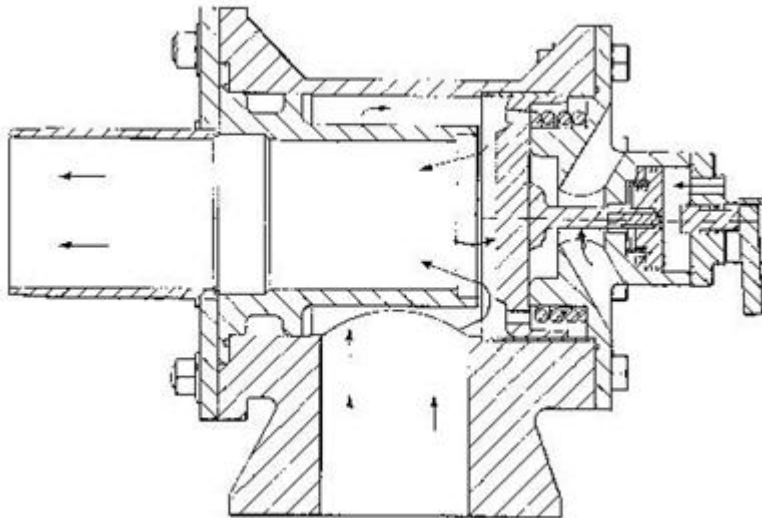

References

Informative references

Attention is drawn to the following places, which may be of interest for search:

Using a resonator, e.g. supersonic generator	B65D 88/665
Operating means; Releasing devices	F16K 31/00

B65D 88/706

{Aerating means, e.g. one-way check valves}

Definition statement

This place covers:

Illustrative example of subject matter classified in this group:

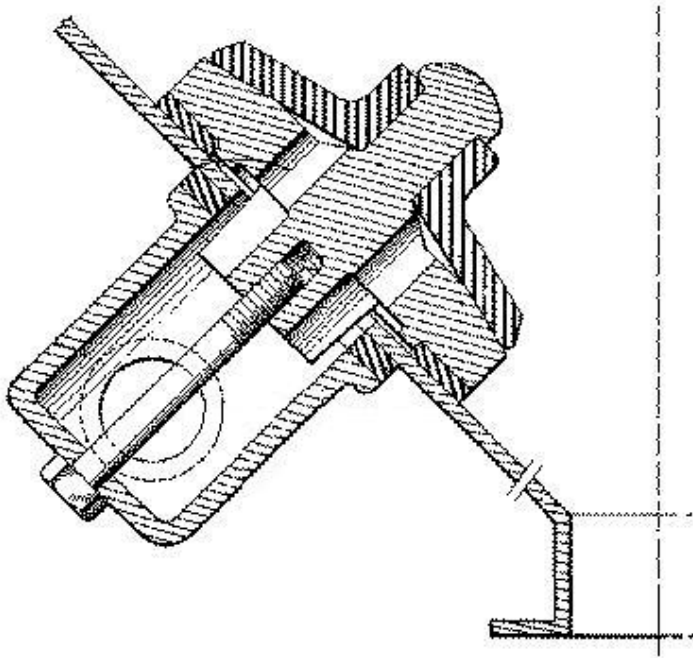

References

Informative references

Attention is drawn to the following places, which may be of interest for search:

Parts, e.g. diffusion elements; Accessories	B01F 33/409
---	-----------------------------

B65D 88/72**Fluidising devices****Definition statement**

This place covers:

Illustrative example of subject matter classified in this group:

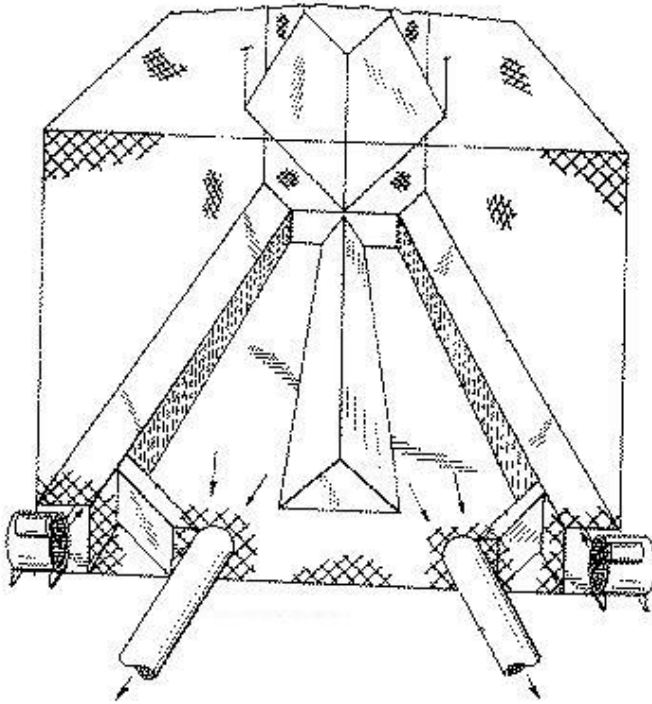
**References****Informative references**

Attention is drawn to the following places, which may be of interest for search:

Using fluid jets	B65D 88/70
Gas pressure systems operating with fluidisation of the materials	B65G 53/16
Fluidising	B65G 69/06

B65D 88/74

having means for heating, cooling, aerating or other conditioning of contents

References**Limiting references**

This place does not cover:

Adaptations of heating or cooling devices for liquids to be transferred	B67D 7/80
Refrigerated cart	F25D

Including a cooling device	F25D 11/003 , F25D 19/003
----------------------------	--

Special rules of classification

The use of available Indexing Codes is mandatory.

B65D 88/741

{aerating by ambient air through openings in the wall}

Definition statement

This place covers:

Illustrative example of subject matter classified in this group:

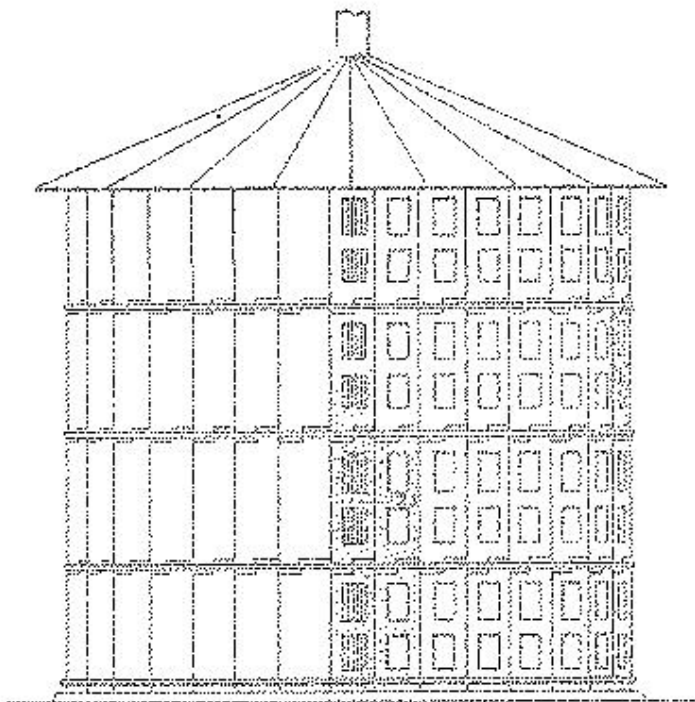

References

Informative references

Attention is drawn to the following places, which may be of interest for search:

Using ventilating sheaths	B65D 88/742
---------------------------	-----------------------------

Special rules of classification

The use of available Indexing Codes is mandatory.

B65D 88/742

{using ventilating sheaths}

Definition statement

This place covers:

Illustrative example of subject matter classified in this group:

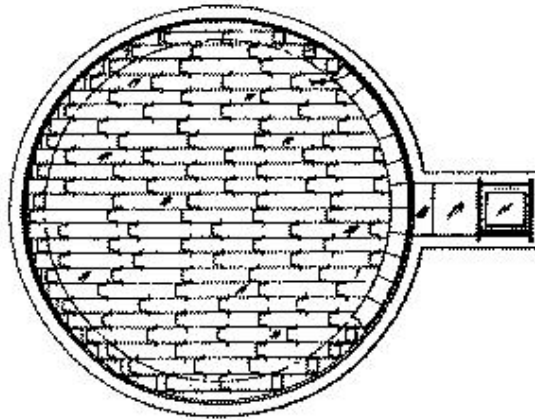
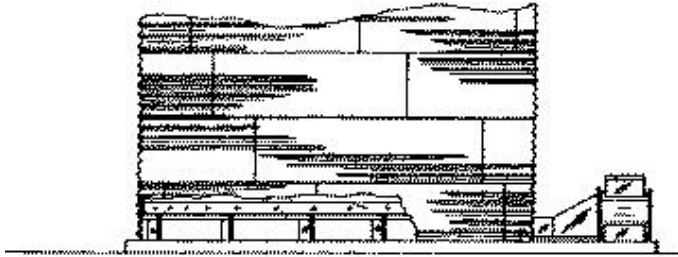

References

Informative references

Attention is drawn to the following places, which may be of interest for search:

Aerating by ambient air through openings in the wall	B65D 88/741
--	-----------------------------

Special rules of classification

The use of available Indexing Codes is mandatory.

B65D 88/748

{for tank containers}

Definition statement

This place covers:

Illustrative example of subject matter classified in this group:

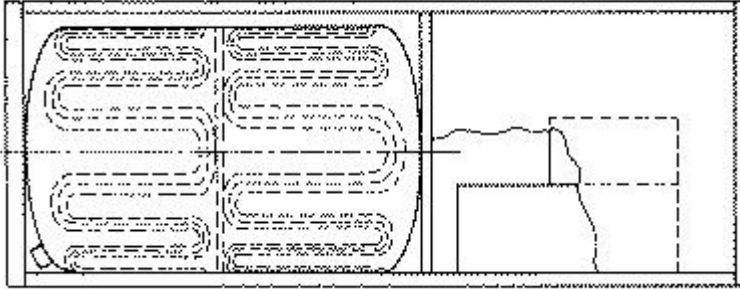

Special rules of classification

The use of available Indexing Codes is mandatory.

B65D 88/76

for use underground (manholes, inspection openings, covers therefor [B65D 90/105](#); {special vessels for collecting or storing rain-water for use in the household [E03B 3/03](#); cesspools [E03F 11/00](#)})

Definition statement

This place covers:

Illustrative example of subject matter classified in this group:

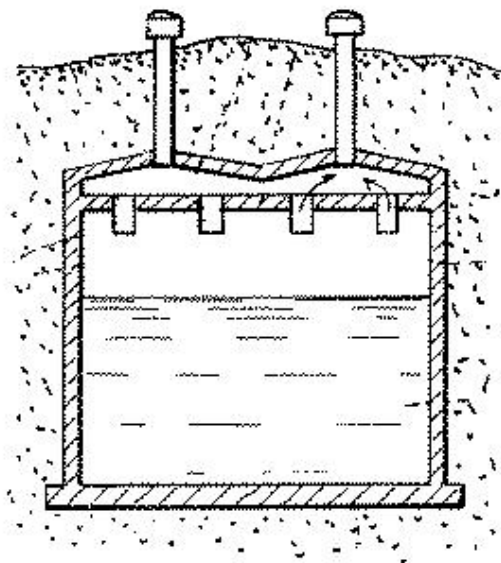
**References****Informative references**

Attention is drawn to the following places, which may be of interest for search:

Spillage-retaining means, e.g. recovery ponds	B65D 90/24
Methods from installations for obtaining or collecting drinking water or tap water from rain-water	E03B 3/02

B65D 88/78

for use in or under water (manholes, inspection openings, covers therefor
[B65D 90/10](#))

Definition statement

This place covers:

Illustrative example of subject matter classified in this group:

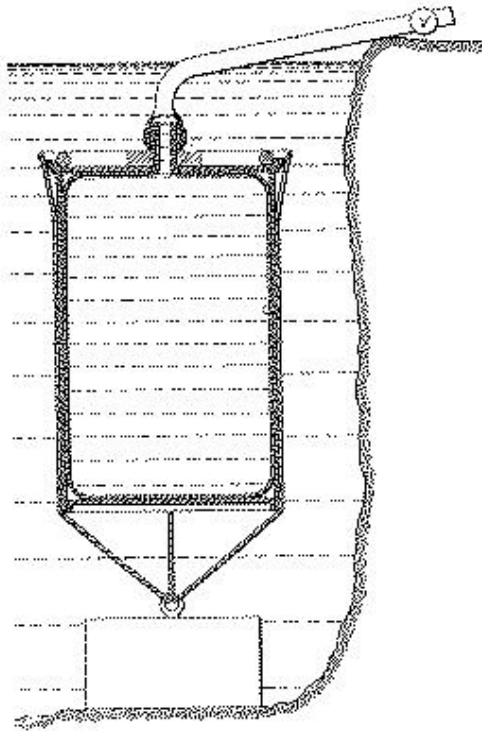
**References****Limiting references**

This place does not cover:

Bouncy for container	B65D 90/00 , B65D 90/22
For transporting iceberg	B63B 35/086

Informative references

Attention is drawn to the following places, which may be of interest for search:

Barges or lighter	B63B 35/28
Structures characteristic of submerged tanks (FTCLA)	3E070/WE00

B65D 90/00

Component parts, details or accessories for large containers
([B65D 88/34](#) - [B65D 88/78](#) take precedence)

References

Limiting references

This place does not cover:

Large containers having floating covers	B65D 88/34
Large containers for use in or under water	B65D 88/78
Transferring or trans-shipping at storage areas	B65G 63/004
Logistic	G06Q 10/08

Informative references

Attention is drawn to the following places, which may be of interest for search:

Trans-receiver or transponder	B65D 2203/10 , G06K
Accessories characteristic of containers (FTCLA)	3E070/WJ00

Special rules of classification

The use of available Indexing Codes is mandatory.

B65D 90/0006

{Coupling devices between containers, e.g. ISO-containers (coupling devices between containers and vehicles [B60P 7/13](#))}

Definition statement

This place covers:

Illustrative examples of subject matter classified in this group:

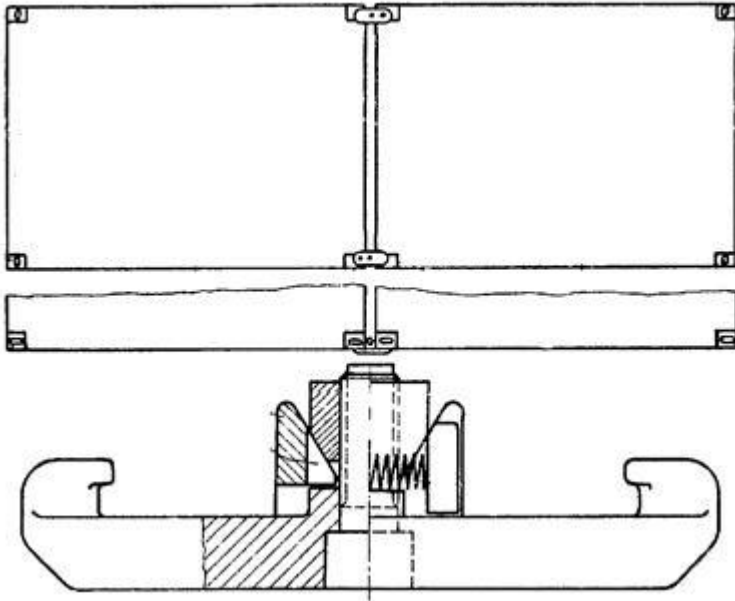
**References****Limiting references**

This place does not cover:

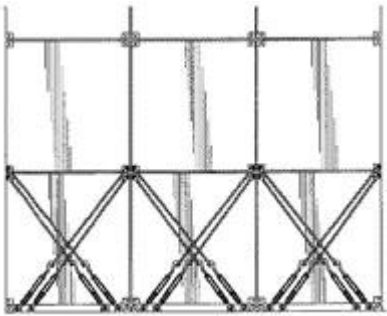
Securing freight containers or forwarding containers on vehicles	B60P 7/13
Container lashings 	B63B

Special rules of classification

The use of available Indexing Codes is mandatory.

B65D 90/0013**{Twist lock}****Definition statement***This place covers:*

Illustrative example of subject matter classified in this group:

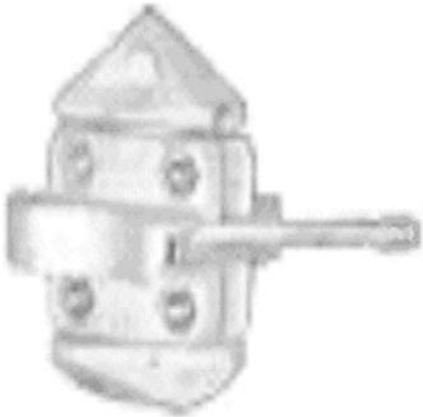
**References****Limiting references***This place does not cover:*

Coupling devices between containers on vehicles using twist-Locks	B60P 7/132
Fixing containers on railway carriage	B61D 45/007
Coupling devices between containers on ships	B63B 25/004
Coupling with lifting device	B66C 1/663
Locks or fastenings for railway freight cars or the like, for lorries, for forwarding containers	E05B 83/02 - E05B 83/14

Informative references*Attention is drawn to the following places, which may be of interest for search:*

All side walls hingedly connected	B65D 88/522
Vertical connection means (FTCLA)	3E070/WJ01
Horizontal connection (FTCLA)	3E070/WJ02, 3E070/WJ03

Special rules of classificationSemi or fully automatic twist lock add [B65D 2590/0033](#).

The use of available Indexing Codes is mandatory.

B65D 90/002

{Apparatus for manual or automatic installation/removal of twist-lock}

Definition statement

This place covers:

Illustrative examples of subject matter classified in this group:

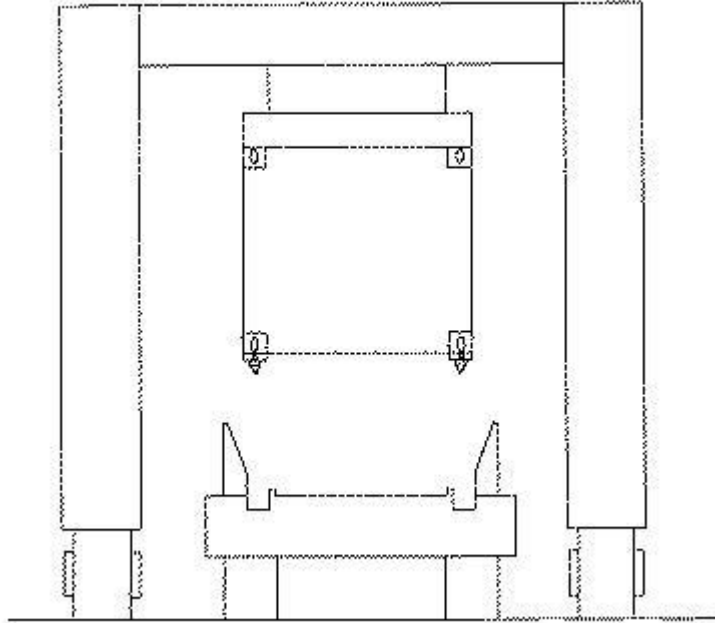

Special rules of classification

The use of available Indexing Codes is mandatory.

B65D 90/0026**{Corner fittings characterised by shape, configuration or number of openings}****Definition statement***This place covers:*

Illustrative examples of subject matter classified in this group:

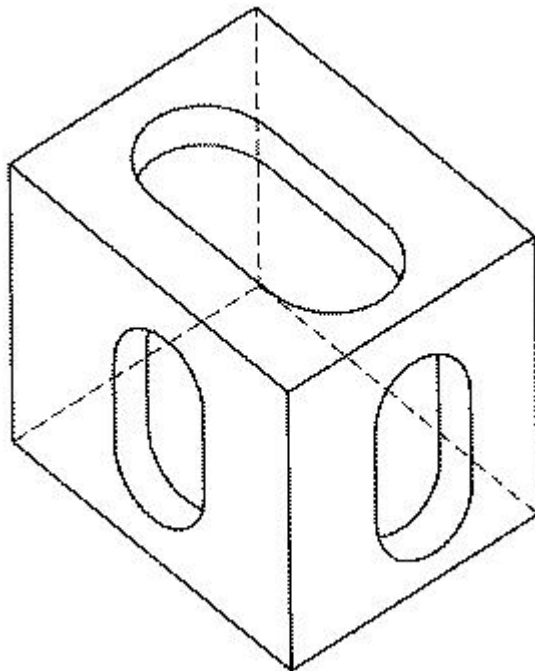
**References*****Informative references****Attention is drawn to the following places, which may be of interest for search:*

Corner hardware (FTCLA)	3E070/WJ04
-------------------------	------------

B65D 90/0033

{Lifting means forming part of the container ([B65D 90/0006](#), [B65D 90/0026](#) take precedence; loading or unloading container on or from a truck [B60P 1/6418](#); lifting the container using a crane [B66C 1/663](#))}

Definition statement

This place covers:

Illustrative examples of subject matter classified in this group:

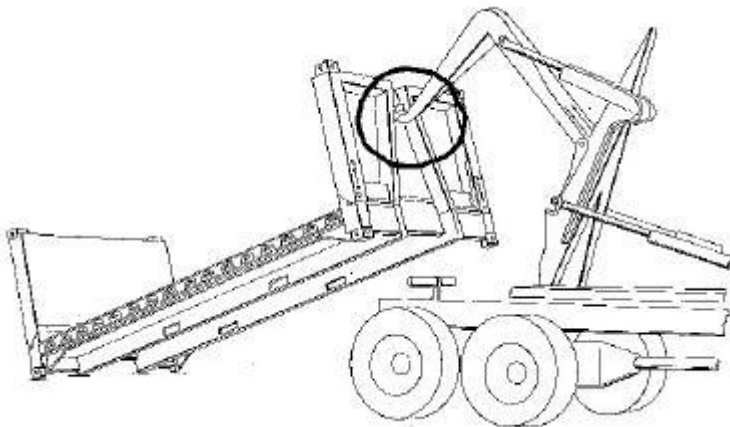

References

Limiting references

This place does not cover:

Small container	B65D 25/22
FIBC	B65D 88/1675
Coupling devices between containers	B65D 90/0006
Corner fittings characterised by shape, configuration or number of openings	B65D 90/0026
Pallets	B65D 2519/00786
Loading or unloading container on or from a truck	B60P 1/6418
Lifting of container using crane	B66C 1/663
Mobile homes or construction modules	E04G 21/161

Informative references

Attention is drawn to the following places, which may be of interest for search:

Hanging means(FTCLA)	3E070/WJ10
Fork pockets(FTCLA)	3E070/WJ06

B65D 90/004

{Contents retaining means}

Definition statement

This place covers:

Illustrative examples of subject matter classified in this group:

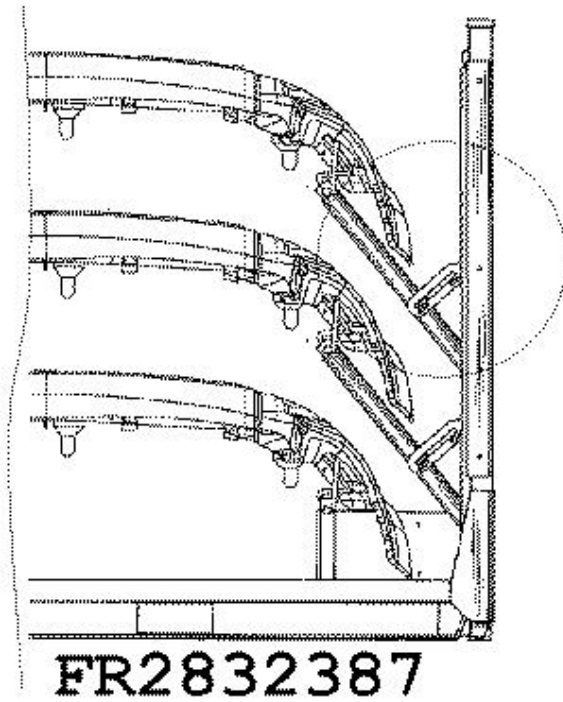
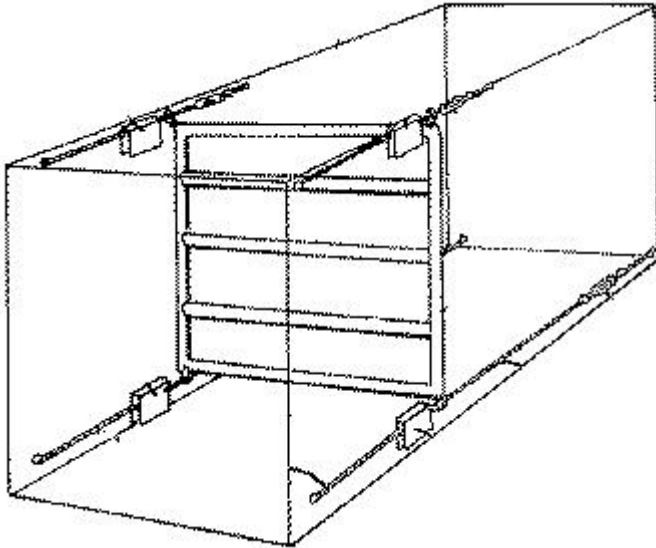

References

Limiting references

This place does not cover:

Locating articles on pallets	B65D 19/44 , B65D 2519/0081
Specially adapted for a specific good	B65D 85/00 , B65D 2585/6802
Bulkheads	B65D 90/047 , B65D 90/048
Partition	B65D 90/52 , B65D 88/60 , B65D 88/62
Vehicles	B65D 2585/6867
Vehicles adapted for carrying vehicles	B60P 3/03
For carrying road vehicles	B60P 3/06 , B60P 3/07
Covering/securing of loads on vehicles	B60P 7/02 , B60P 7/06
Securing freight containers on vehicles	B60P 7/13
Securing freight containers on aircraft	B64D 9/00
Devices for retaining pallets or freight containers	B64D 9/003
Stack holders or separators, details of the separators only	B65G 1/14
Loading-unloading of container	B65G 2201/0235
Parking for vehicles and equipment therefore	E04H 6/00
For wind motor blades	F03D 80/00

Informative references

Attention is drawn to the following places, which may be of interest for search:

Elements or devices for locating articles on platforms	B65D 19/44
Body parts, e.g. doors, body panels	B65D 2585/6887
Stack holders or separators	B65G 1/14

B65D 90/008

{Doors for containers, e.g. ISO-containers (locking [E05B 83/12](#))}

Definition statement

This place covers:

Illustrative example of subject matter classified in this group:

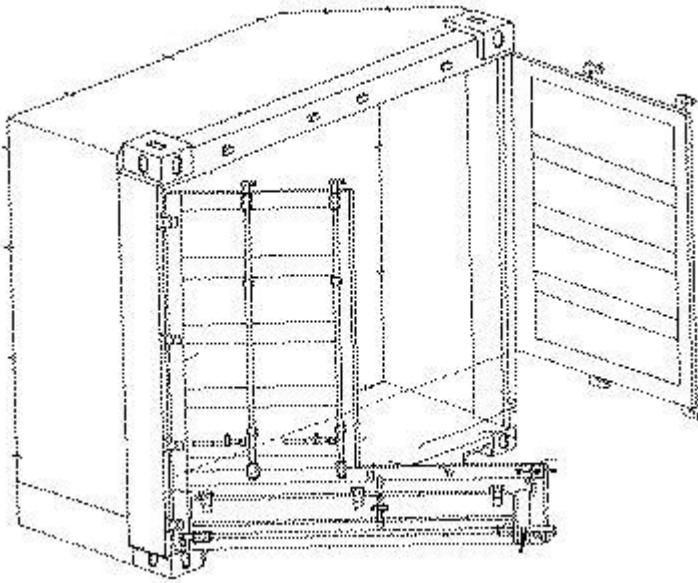
**References****Limiting references**

This place does not cover:

Open sided container	B65D 88/127
Flexible side walls, e.g. curtains	B65D 90/021
Antitheft means	B65D 90/22 , B65D 2211/00
Doors for vehicles	B60J 5/00
Side doors for vehicles	B60J 5/04
Doors for rail vehicles	B61D 19/003
Giving indication of authorised or unauthorised unlocking	E05B 39/00
Locking for back doors with a rotary bar	E05B 83/10
Locking for back doors of a van or container	E05B 83/12
Other devices specially designed for securing wings of doors	E05C 19/00
Hinges in general	E05D

B65D 90/0086**{rotating or wound around a horizontal axis}****Definition statement***This place covers:*

Illustrative example of subject matter classified in this group:

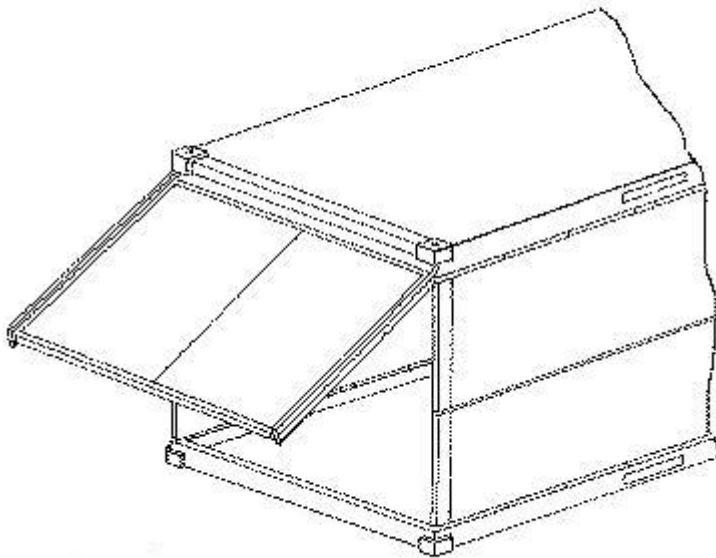
**References****Limiting references***This place does not cover:*

Flexible doors side walls or doors	B65D 90/021
------------------------------------	-----------------------------

B65D 90/02

Wall construction (arrangements of leakage-indicating devices comprising hollow spaces within walls [B65D 90/501](#); arrangements of leakage-indicating devices comprising porous spaces or porous layers in walls [B65D 90/505](#); arrangements of leakage-indicating devices comprising electrically conductive layers in walls [B65D 90/513](#))

References**Limiting references***This place does not cover:*

arrangements of leakage-indicating devices comprising hollow spaces within walls	B65D 90/501
--	-----------------------------

arrangements of leakage-indicating devices comprising porous spaces or porous layers in walls	B65D 90/505
arrangements of leakage-indicating devices comprising electrically conductive layers in walls	B65D 90/513

Special rules of classification

The use of available Indexing Codes is mandatory.

B65D 90/021

{Flexible side walls or doors ([B65D 88/125](#) takes precedence)}

Definition statement

This place covers:

Illustrative example of subject matter classified in this group:

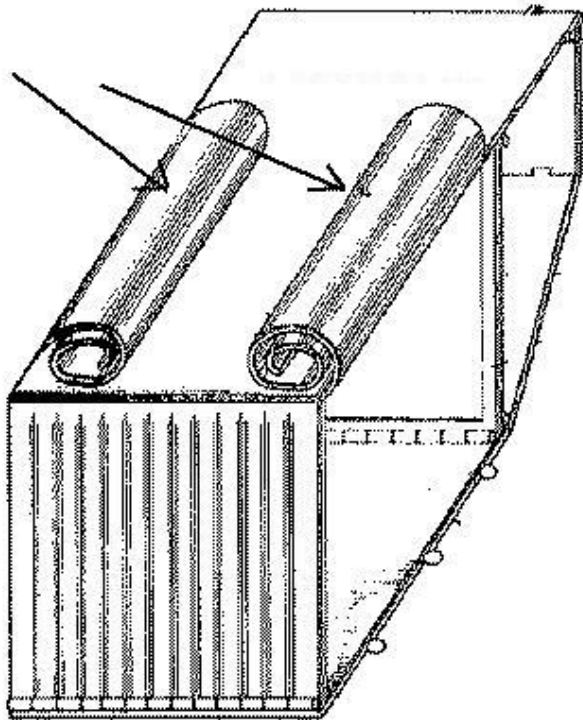

References

Limiting references

This place does not cover:

Flexible top	B65D 88/125
Flexible container	B65D 88/16

Informative references

Attention is drawn to the following places, which may be of interest for search:

With rigid end walls	B65D 88/20
----------------------	----------------------------

Special rules of classification

The use of available Indexing Codes is mandatory.

B65D 90/022

{Laminated structures ([B65D 90/029](#) takes precedence)}

Definition statement

This place covers:

Illustrative example of subject matter classified in this group.

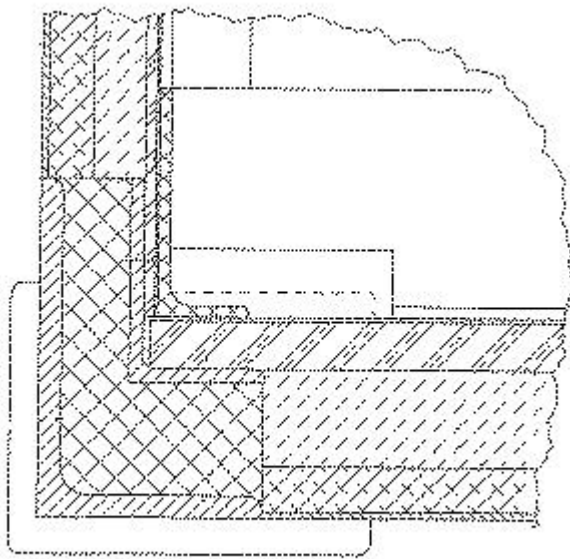

References

Limiting references

This place does not cover:

Wound structures	B65D 90/029
------------------	-----------------------------

Informative references

Attention is drawn to the following places, which may be of interest for search:

Coverings, e.g. for insulating purposes	B65D 90/06
---	----------------------------

Special rules of classification

Arrangements of leakage-indicating devices comprising porous spaces or layers in walls are only classified in [B65D 90/505](#).

Arrangements of leakage-indicating devices comprising electrically conductive layers in walls are only classified in [B65D 90/513](#).

The use of available Indexing Codes is mandatory.

B65D 90/023**{Modular panels}****References****Limiting references***This place does not cover:*

Collapsible container	B65D 88/52
-----------------------	----------------------------

Informative references*Attention is drawn to the following places, which may be of interest for search:*

Construction or assembling of bulk storage containers employing civil engineering techniques in situ or off site	E04H 7/00
--	---------------------------

Special rules of classification

The use of available Indexing Codes is mandatory.

B65D 90/024**{with features of cylindrical curvature}****Definition statement***This place covers:*

Illustrative example of subject matter classified in this group:

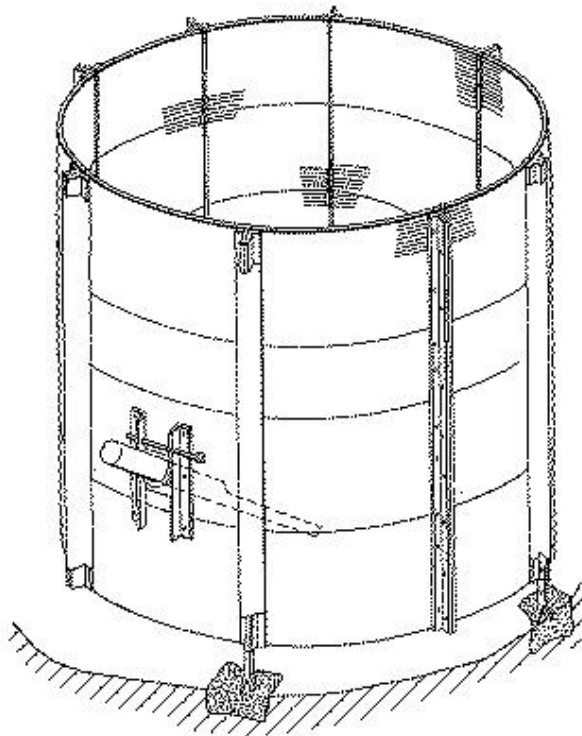

Special rules of classification

The use of available Indexing Codes is mandatory.

B65D 90/025

{with features of spheroidal curvature}

Definition statement

This place covers:

Illustrative example of subject matter classified in this group:

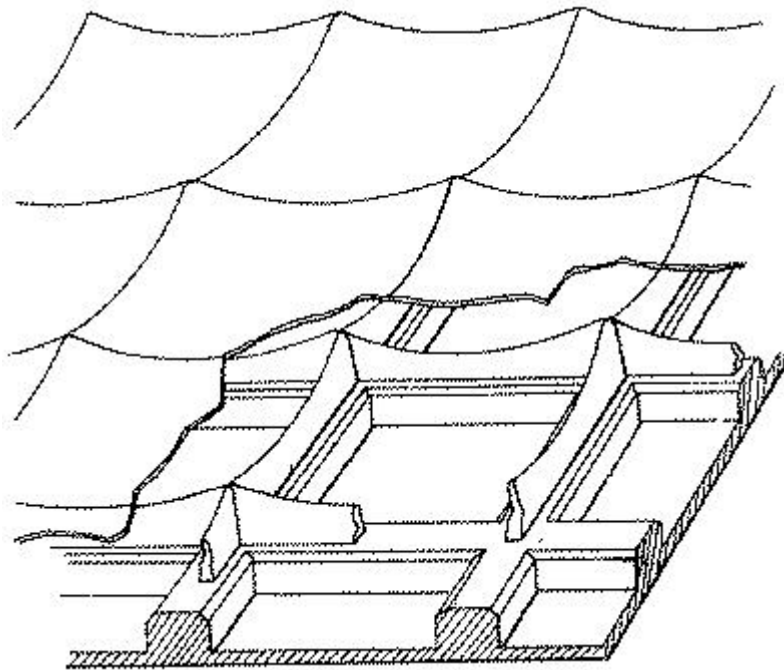

Special rules of classification

The use of available Indexing Codes is mandatory.

B65D 90/026

{Parallel slats}

Definition statement

This place covers:

Illustrative example of subject matter classified in this group:

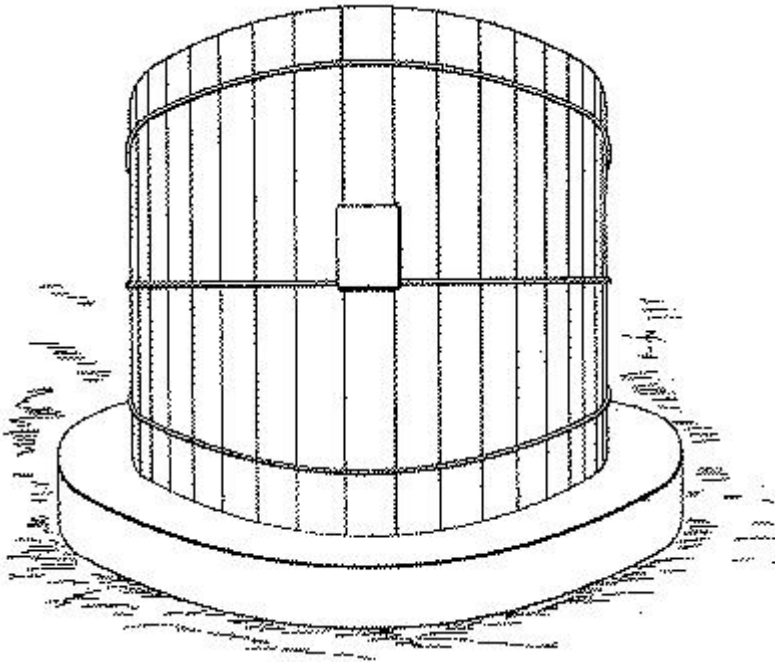

Special rules of classification

The use of available Indexing Codes is mandatory.

B65D 90/027

{Corrugated or zig-zag structures; Folded plate}

Definition statement

This place covers:

Illustrative example of subject matter classified in this group:

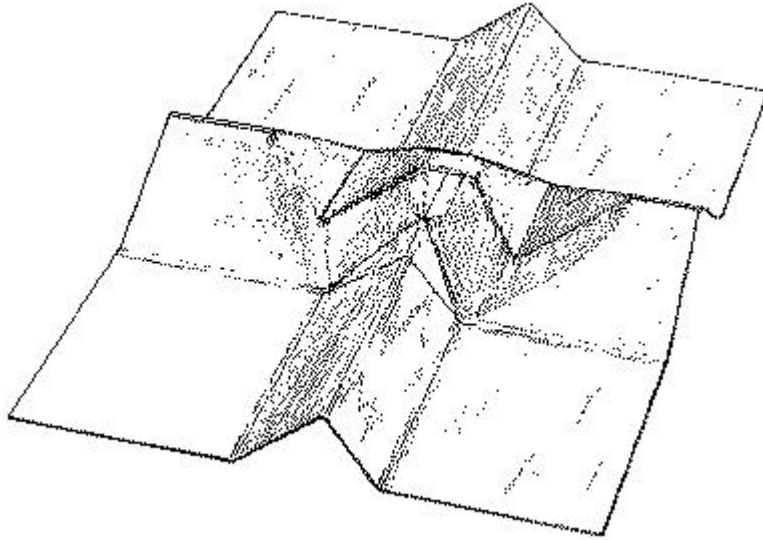

Special rules of classification

The use of available Indexing Codes is mandatory.

B65D 90/028

{hollow-walled, e.g. double-walled with spacers (linings [B65D 90/04](#))}

Definition statement

This place covers:

Illustrative example of subject matter classified in this group:

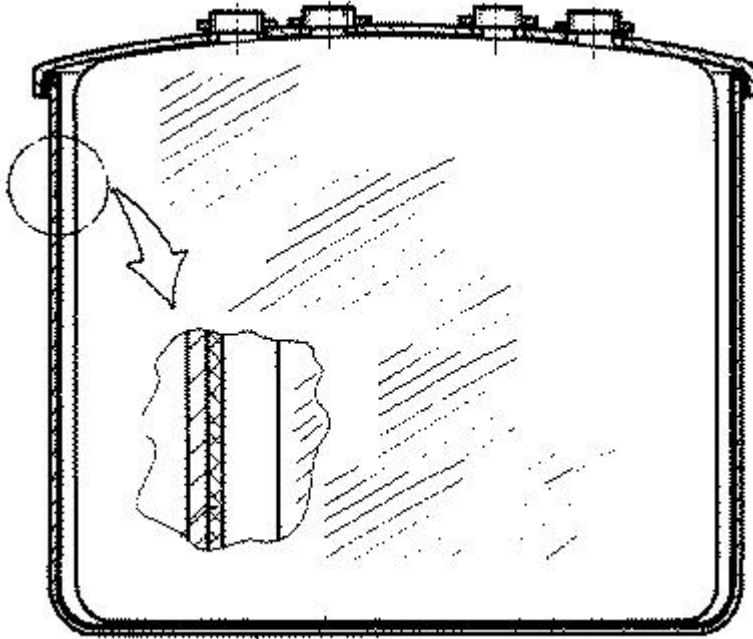
**References****Limiting references**

This place does not cover:

Linings	B65D 90/04
---------	----------------------------

Special rules of classification

Arrangements of leakage-indicating devices comprising hollow spaces within walls are only classified in [B65D 90/501](#).

The use of available Indexing Codes is mandatory.

B65D 90/029**{Wound structures}****Definition statement***This place covers:*

Illustrative example of subject matter classified in this group:

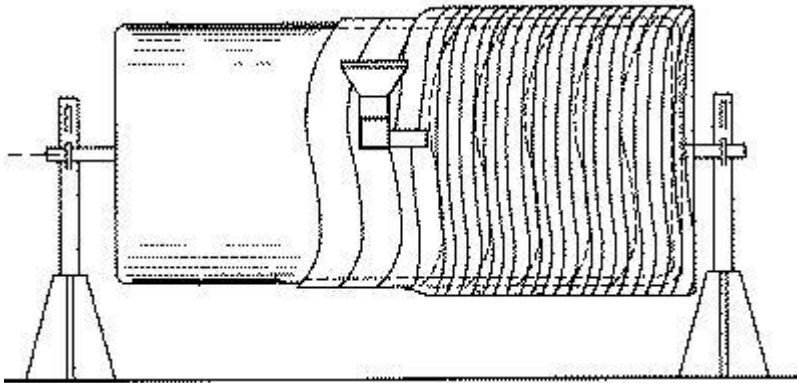
**Special rules of classification**

The use of available Indexing Codes is mandatory.

B65D 90/04**Linings {(for flexible containers [B65D 88/1606](#))}****References****Limiting references***This place does not cover:*

Lining or sheathing of internal surfaces	B29C 63/26
--	----------------------------

Special rules of classification

The use of available Indexing Codes is mandatory.

B65D 90/041**{Rigid liners fixed to the container}****References****Informative references***Attention is drawn to the following places, which may be of interest for search:*

Laminated structures	B65D 90/022
----------------------	-----------------------------

Special rules of classification

The use of available Indexing Codes is mandatory.

B65D 90/043

{the liners being in the form of tiles or panels}

Definition statement

This place covers:

Illustrative example of subject matter classified in this group:

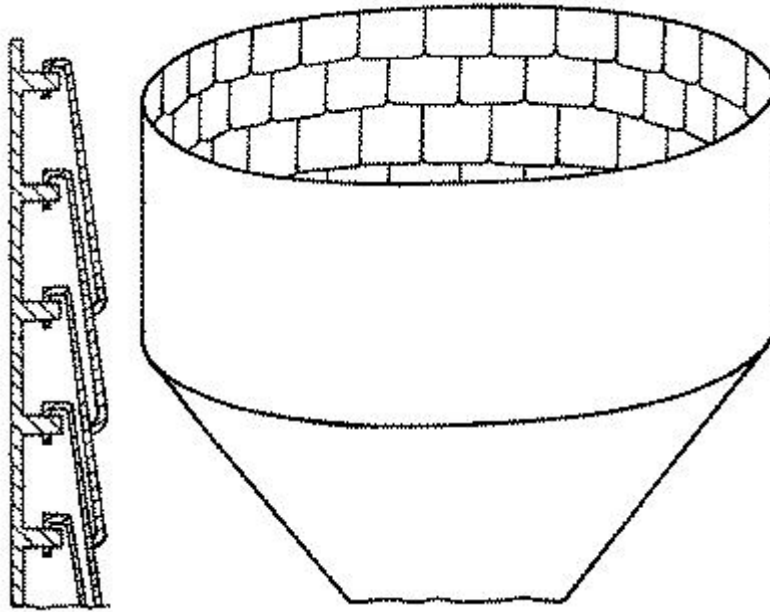
**Special rules of classification**

The use of available Indexing Codes is mandatory.

B65D 90/046

{Flexible liners, e.g. loosely positioned in the container}

Definition statement

This place covers:

Illustrative examples of subject matter classified in this group:

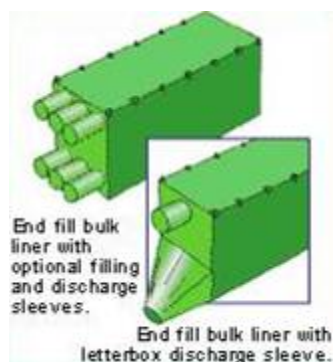

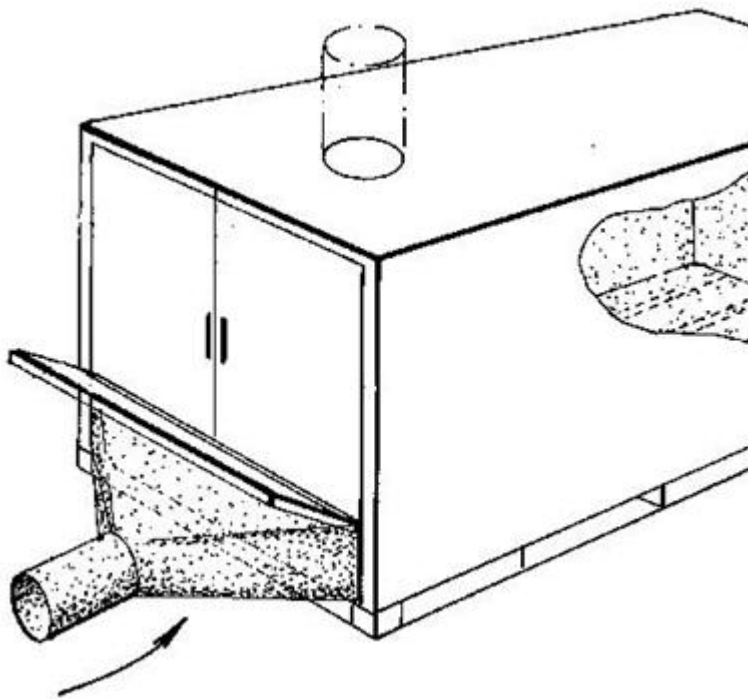

References

Limiting references

This place does not cover:

For smaller container (also 1000 lt) or in general	B65D 77/06 , B65D 77/061
Flexible container for transport	B65D 88/16 , B65D 88/1612 , B65D 88/22
Flexible spout are spread	B65D 88/1668 , B65D 90/56 , B65D 88/62 , B65D 88/26
Details of the liner	B65D 90/047 , B65D 90/048
Frame for flexible liners	B65D 90/205
Closure means	B65D 90/54 , B65D 90/008
Lining or sheathing of internal surfaces	B29C 63/26

Informative references

Attention is drawn to the following places, which may be of interest for search:

Large containers	B65D 88/62
Arrangements of leakage-indicating devices	B65D 90/50
Vehicles adapted to transport, to carry or to comprise special loads or objects, divided by flexible walls	B60P 3/246

Special rules of classification

For bladder type liner classify use Indexing Code [B65D 2590/046](#).

The use of available Indexing Codes is mandatory.

B65D 90/047

{comprising rigid bracing, e.g. bulkheads}

Definition statement

This place covers:

Illustrative example of subject matter classified in this group:

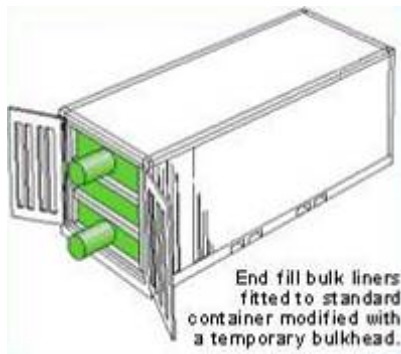

Special rules of classification

For bladder type liner classify use Indexing Code [B65D 2590/046](#)

The use of available Indexing Codes is mandatory.

B65D 90/048

{comprising bracing straps}

Definition statement

This place covers:

Illustrative example of subject matter classified in this group:

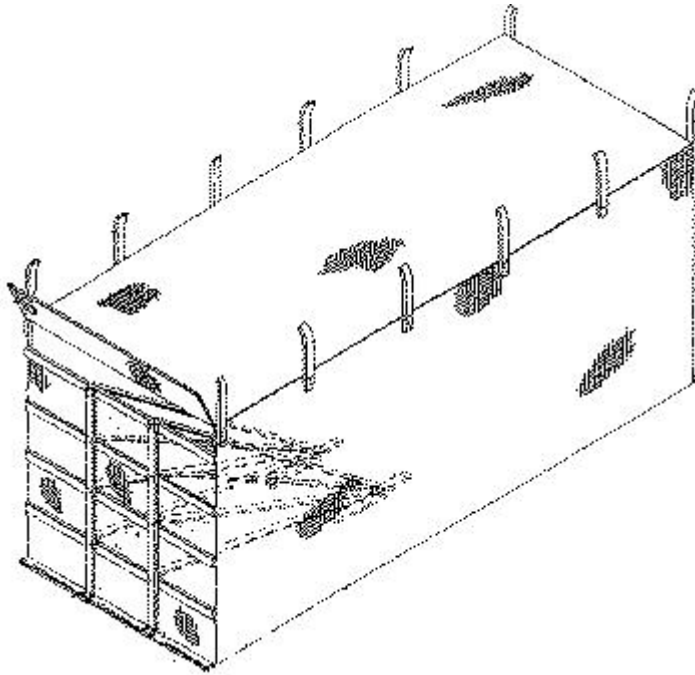

Special rules of classification

For bladder type liner classify use Indexing Code [B65D 2590/046](#)

The use of available Indexing Codes is mandatory.

B65D 90/06

Coverings, e.g. for insulating purposes

Definition statement

This place covers:

Illustrative example of subject matter classified in this group:

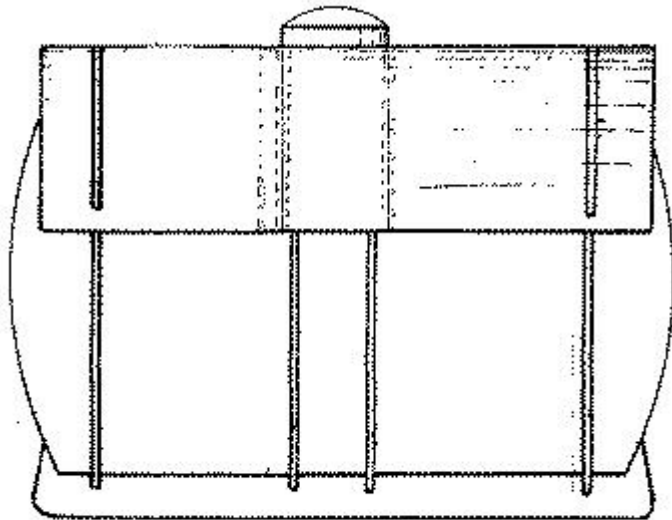

B65D 90/08

Interconnections of wall parts; Sealing means therefor

Definition statement

This place covers:

Illustrative example of subject matter classified in this group:

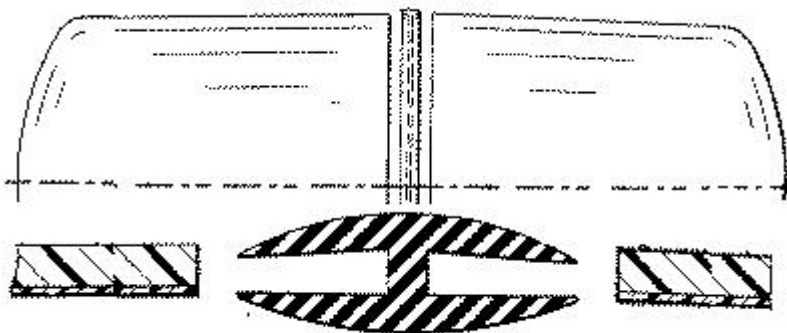

References

Limiting references

This place does not cover:

Joining of furniture or the like	F16B 12/00
Furniture tubing	F16B 12/40

Informative references

Attention is drawn to the following places, which may be of interest for search:

Especially corner connections	B65D 88/14
All side walls detached from each other to collapse the container	B65D 88/528

B65D 90/10

Manholes; Inspection openings; Covers therefor (safety features [B65D 90/22](#); covers or similar closure members, for pressure vessels in general [F16J 13/00](#))

Definition statement

This place covers:

Illustrative example of subject matter classified in this group:

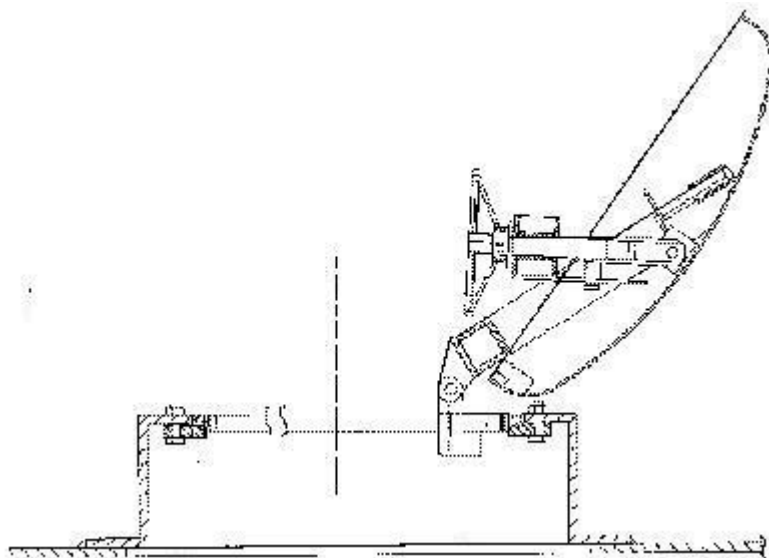

References

Limiting references

This place does not cover:

Closure, lid for completely opening of the container top	B65D 88/124
Closing means	B65D 90/54
Manholes in general	E02D 29/12 , F41H 5/22 , E03F 5/02
Covers for manholes	E02D 29/14

Informative references

Attention is drawn to the following places, which may be of interest for search:

Receptacle closures, covers or doors; Mechanisms for operating them	B01F 35/45
Closures; Sealing mechanisms	B28C 5/4262
Arrangements of access openings or covers therefor	B60P 3/226

B65D 90/105

{for underground containers}

Definition statement

This place covers:

Illustrative example of subject matter classified in this group:

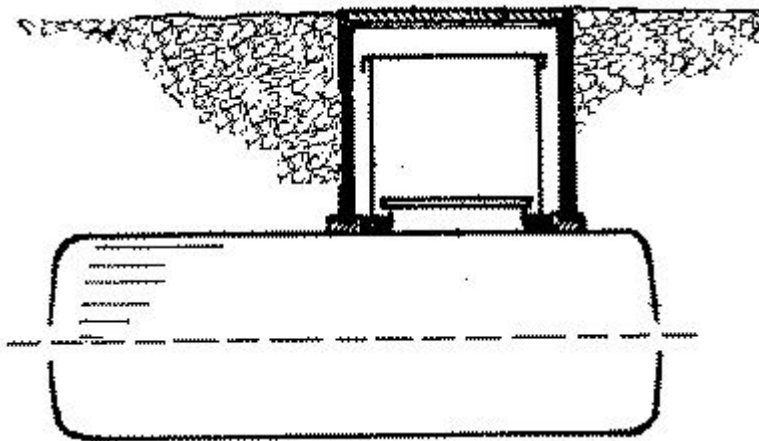
**References****Limiting references**

This place does not cover:

Manhole shafts	E02D 29/12
For sewerage	E03F 5/02

B65D 90/12**Supports****Definition statement**

This place covers:

Illustrative example of subject matter classified in this group:

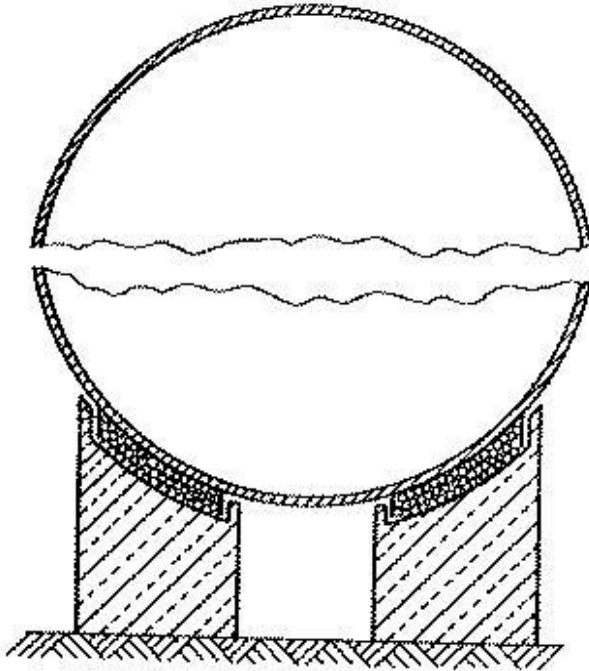
**References****Limiting references**

This place does not cover:

Foundations as substructures	E02D 27/00 , E04B
------------------------------	---

Informative references

Attention is drawn to the following places, which may be of interest for search:

Frames or nets, e.g. for flexible containers	B65D 90/20
--	----------------------------

B65D 90/125**{Docking stations, i.e. for the temporary support of the container}****Definition statement***This place covers:*

Illustrative example of subject matter classified in this group:

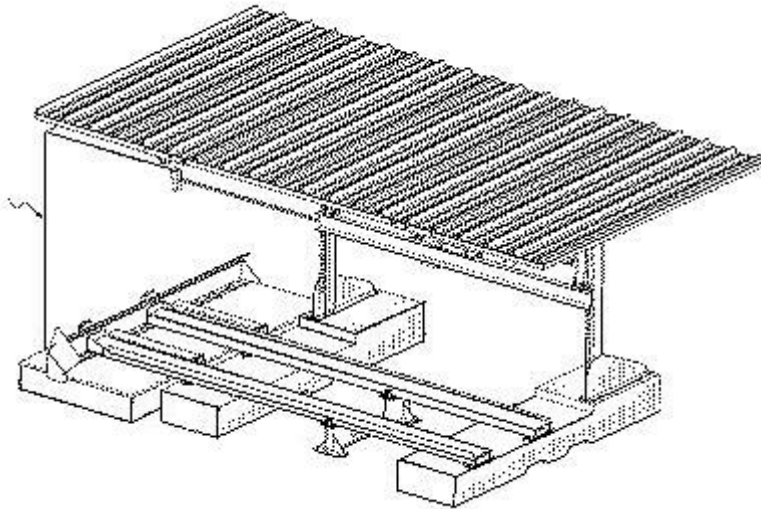
**References****Limiting references***This place does not cover:*

Transferring or trans-shipping at storage areas, railway yards, harbours	B65G 63/00
Fixed ramps	B65G 69/28

Informative references*Attention is drawn to the following places, which may be of interest for search:*

Spillage-retaining means, e.g. recovery ponds	B65D 90/24
---	----------------------------

B65D 90/14**Legs, e.g. detachable****Definition statement***This place covers:*

Illustrative example of subject matter classified in this group:

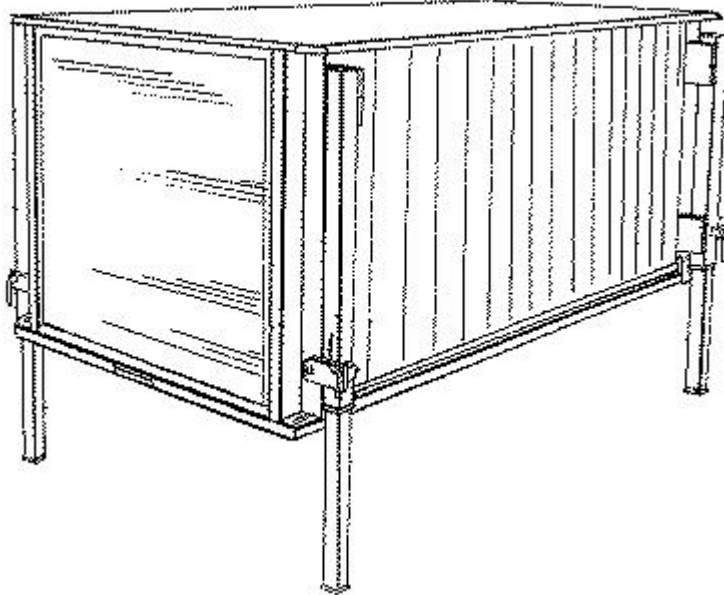
**References****Limiting references***This place does not cover:*

For legs details	B65D 90/143 , B65D 90/146
------------------	--

Informative references*Attention is drawn to the following places, which may be of interest for search:*

Vehicles predominantly for transporting loads and modified to facilitate loading, consolidating the load, or unloading (the load transporting element being a container or similar)	B60P 1/6418
---	-----------------------------

B65D 90/143

{Detachable individual legs}

Definition statement

This place covers:

Illustrative example of subject matter classified in this group:

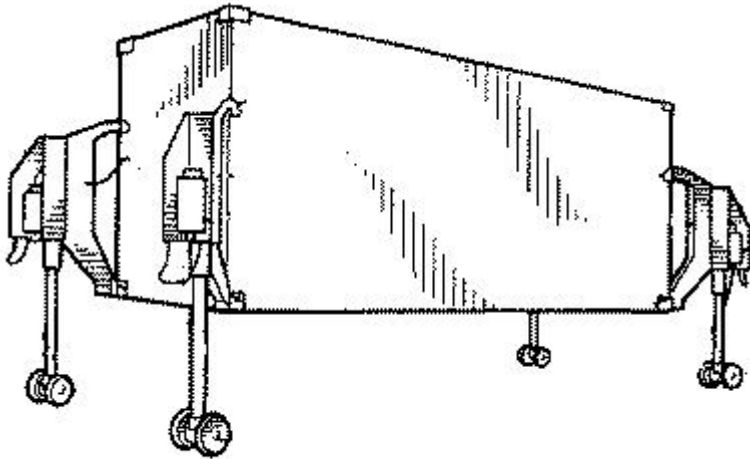

References

Informative references

Attention is drawn to the following places, which may be of interest for search:

Devices adapted for uninterrupted lifting of loads with racks actuated by pinions	B66F 3/02
---	---------------------------

B65D 90/146

{Detachable combined legs}

Definition statement

This place covers:

Illustrative examples of subject matter classified in this group:

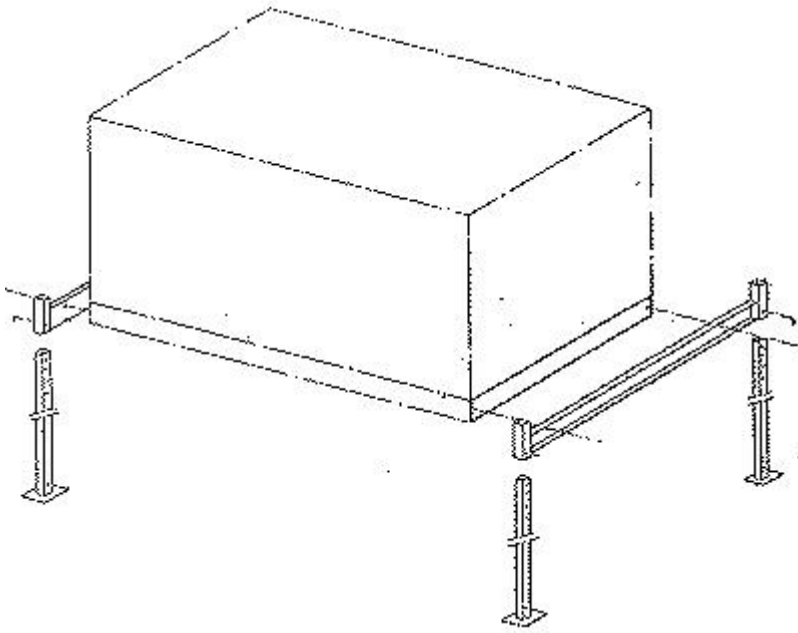

References

Informative references

Attention is drawn to the following places, which may be of interest for search:

Devices adapted for uninterrupted lifting of loads with racks actuated by pinions	B66F 3/02
---	---------------------------

B65D 90/16

Skids

Definition statement

This place covers:

Illustrative examples of subject matter classified in this group:

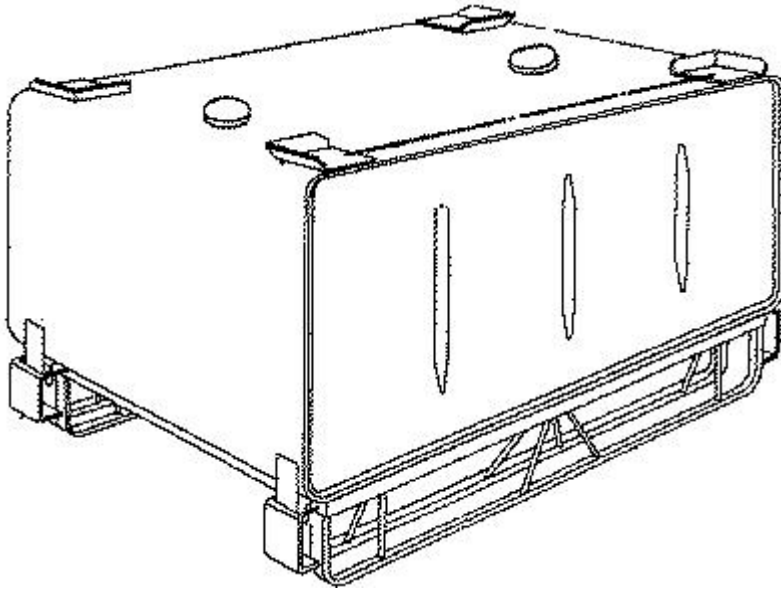

B65D 90/18**Castors, rolls, or the like; e.g. detachable (castors in general [B60B](#))****Definition statement***This place covers:*

Illustrative example of subject matter classified in this group:

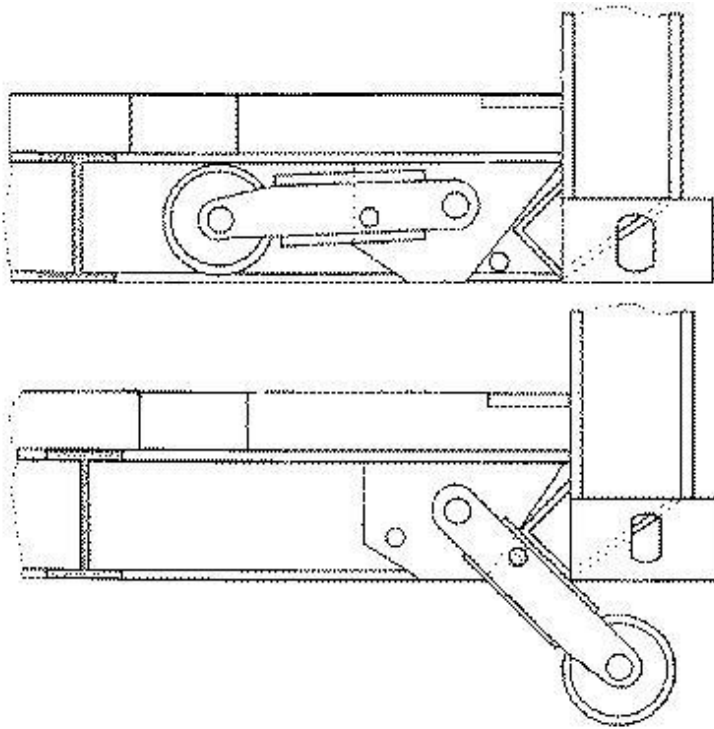
**References****Limiting references***This place does not cover:*

Hand carts	B62B
------------	----------------------

B65D 90/20**Frames or nets, e.g. for flexible containers****References****Limiting references***This place does not cover:*

Articles or materials enclosed in two or more containers disposed one with another (the inner container having a polygonal cross-section)	B65D 77/0453
Articles or materials enclosed in two or more containers disposed one with another (the inner container being a filled deformable tube)	B65D 77/0466

B65D 90/205

{for flexible containers, i.e. the flexible container being permanently connected to the frame ([B65D 77/061](#), [B65D 88/1612](#), [B65D 90/046](#) take precedence; unpacking of Flexible Intermediate Bulk Container [FIBC] [B65B 69/0075](#); crane hooks for frames for FIBC [B66C 1/226](#))}

Definition statement

This place covers:

Illustrative example of subject matter classified in this group.

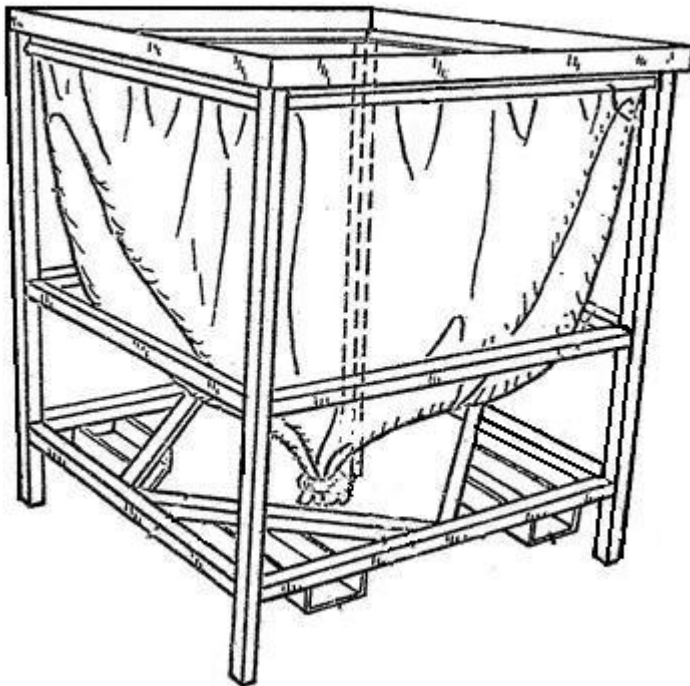

References

Informative references

Attention is drawn to the following places, which may be of interest for search:

Packages formed by enclosing articles or materials in preformed containers, the containers being mounted on a pallet	B65D 77/061
Flexible intermediate bulk containers	B65D 88/1612
With rigid end walls	B65D 88/20
Flexible liners	B65D 90/046

B65D 90/22

Safety features (floating covers [B65D 88/34](#); arrangements of indicating or measuring devices [B65D 90/48](#); fire-fighting [A62C](#))

References**Limiting references**

This place does not cover:

Buoyancy for containers	B65D 88/78
Blasting resistant	B65D 90/325
Anti theft means	B65D 2211/00
For tank container on a truck	B60P 3/229
Temperature monitoring	G01K 3/005 , G01K 13/10 , G05D 23/00
Fire alarms	G08B 17/00

Special rules of classification

The use of available Indexing Codes is mandatory.

B65D 90/24

Spillage-retaining means, e.g. recovery ponds

Definition statement

This place covers:

Illustrative example of subject matter classified in this group:

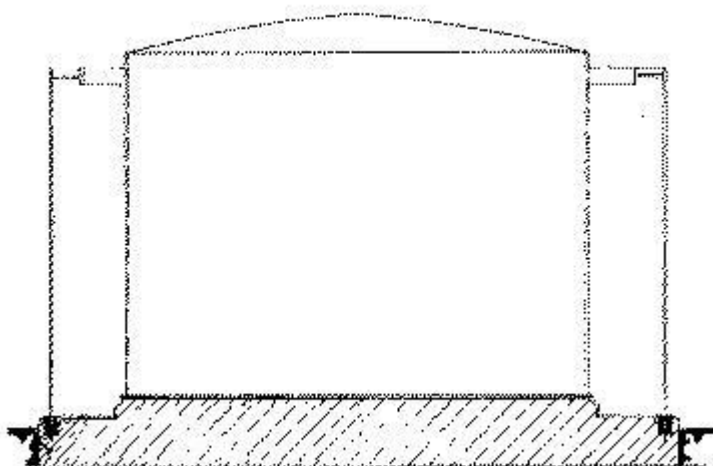

References

Limiting references

This place does not cover:

Petrol stations	B67D 7/3209
Drip trays	F16N 31/006

Informative references

Attention is drawn to the following places, which may be of interest for search:

Docking stations, i.e. for the trans	B65D 90/125
--------------------------------------	-----------------------------

Special rules of classification

The use of available Indexing Codes is mandatory.

B65D 90/26

Overfill prevention (spillage retaining means [B65D 90/24](#); arrangements of indicating or measuring devices [B65D 90/48](#))

Definition statement

This place covers:

Illustrative example of subject matter classified in this group:

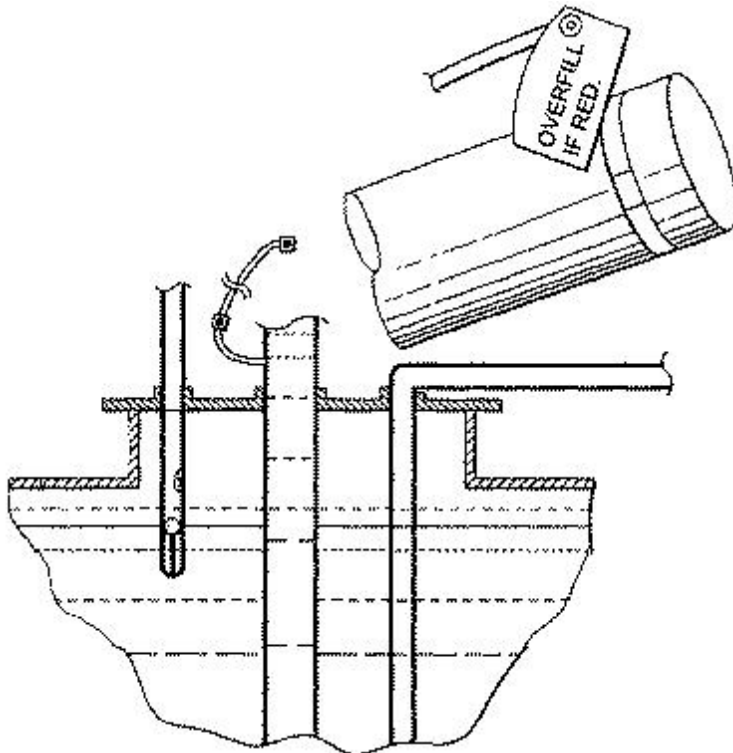

B65D 90/32

Arrangements for preventing, or minimising the effect of, excessive or insufficient pressure (valves per se [F16K](#))

Definition statement

This place covers:

Illustrative example of subject matter classified in this group:

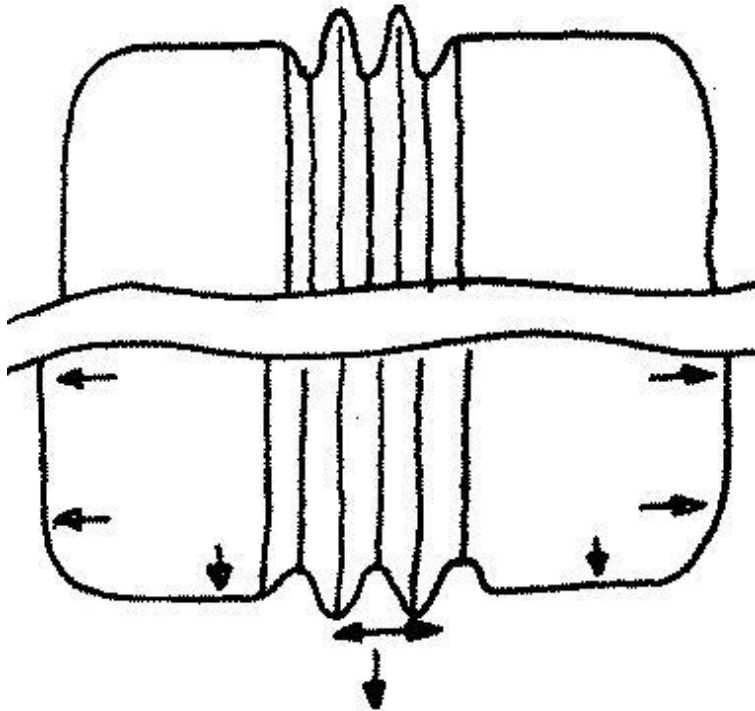

References

Informative references

Attention is drawn to the following places, which may be of interest for search:

Venting means	B65D 90/34
---------------	----------------------------

B65D 90/34

Venting means (vehicle fuel tanks characterised by venting means [B60K 15/035](#))

Definition statement

This place covers:

Illustrative example of subject matter classified in this group:

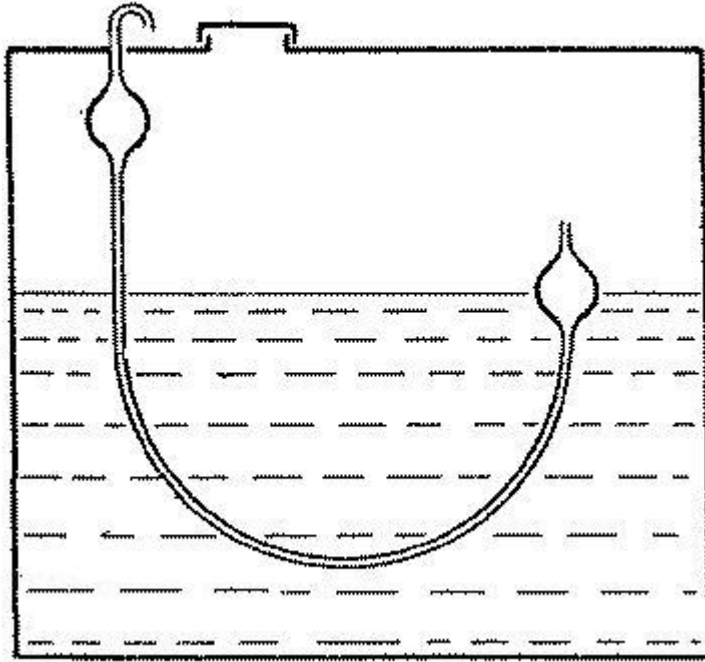

References

Limiting references

This place does not cover:

Tank vehicles	B60P 3/2255
---------------	-----------------------------

B65D 90/36

Weakened parts

Definition statement

This place covers:

Illustrative example of subject matter classified in this group:

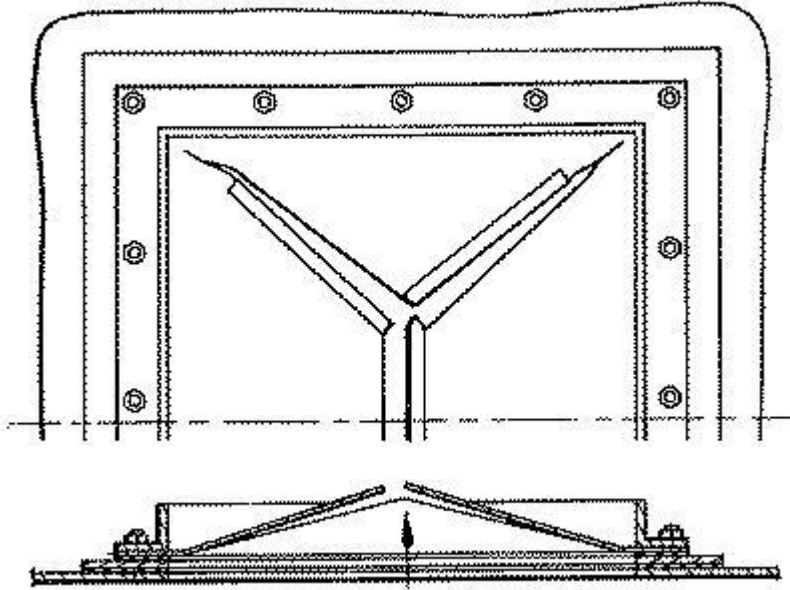

References

Informative references

Attention is drawn to the following places, which may be of interest for search:

Protection against vibrations or shocks; against mechanical destruction	E04B 1/98
Safety and equalising valves with fracturing diaphragm	F16K 17/16

B65D 90/38

Means for reducing the vapour space or for reducing the formation of vapour within containers

Definition statement

This place covers:

Illustrative example of subject matter classified in this group:

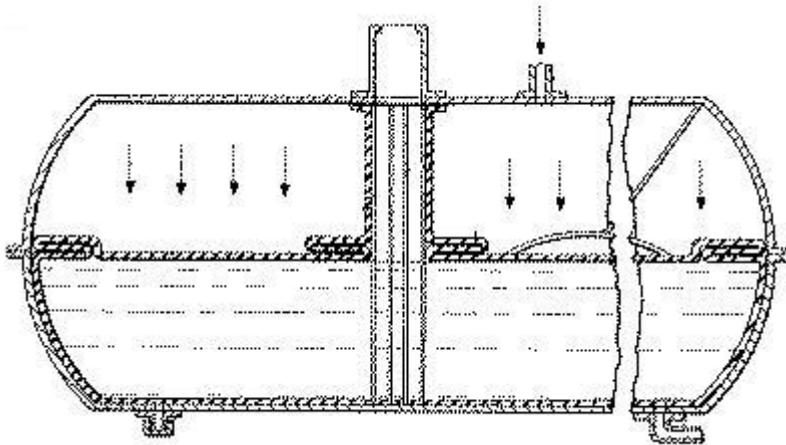
**References****Limiting references**

This place does not cover:

Floating covers	B65D 88/34
-----------------	----------------------------

B65D 90/42

by use of particular materials for covering surface of liquids

References**Informative references**

Attention is drawn to the following places, which may be of interest for search:

Having floating covers with relatively movable sections	B65D 88/36
---	----------------------------

B65D 90/46

Arrangements for carrying off, or preventing the formation of electrostatic charges (carrying-off, or preventing the formation of electrostatic charges in general [H05F](#))

Definition statement

This place covers:

Illustrative example of subject matter classified in this group:

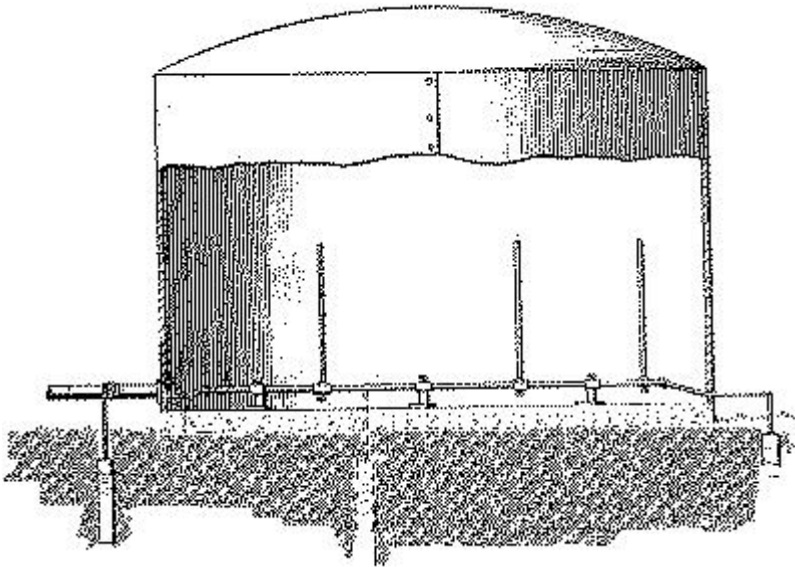

References

Limiting references

This place does not cover:

Flexible containers	B65D 88/165
Small containers	B65D 2213/02
Automobile tanks	B60K 15/00
Tank vehicles	B60P 3/2275
Taps	B67D 7/3236
Arrangements for measuring phase angle between a voltage and a current, or between voltages or currents	G01R 25/00
Preventing the formation of electrostatic charges	H05F 1/00
Carrying-off electrostatic charges	H05F 3/00

B65D 90/48**Arrangements of indicating or measuring devices****References*****Limiting references****This place does not cover:*

Investigating fluid tightness of structures in petrol station	B67D 7/3209
Indicating or measuring liquid level	G01F 22/00

B65D 90/50**of leakage-indicating devices****References*****Informative references****Attention is drawn to the following places, which may be of interest for search:*

Repair kit	B65D 90/00 , B65D 90/22
Spillage-retaining means	B65D 90/24
investigating fluid-tightness of structures	G01M 3/00

B65D 90/501

comprising hollow spaces within walls

Definition statement

This place covers:

Illustrative example of subject matter classified in this group (CH517630).

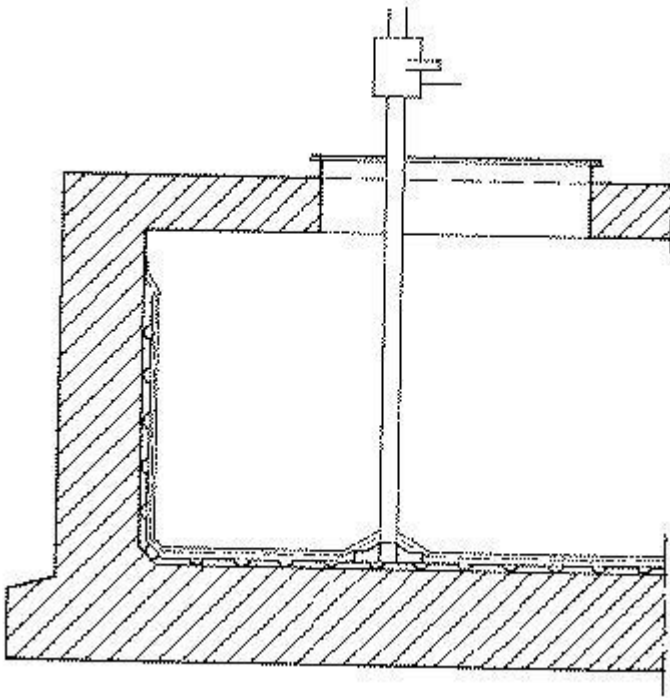

References

Informative references

Attention is drawn to the following places, which may be of interest for search:

Hollow walls construction	B65D 90/028
---------------------------	-----------------------------

B65D 90/505

comprising porous spaces or porous layers in walls

Definition statement

This place covers:

Illustrative example of subject matter classified in this group:

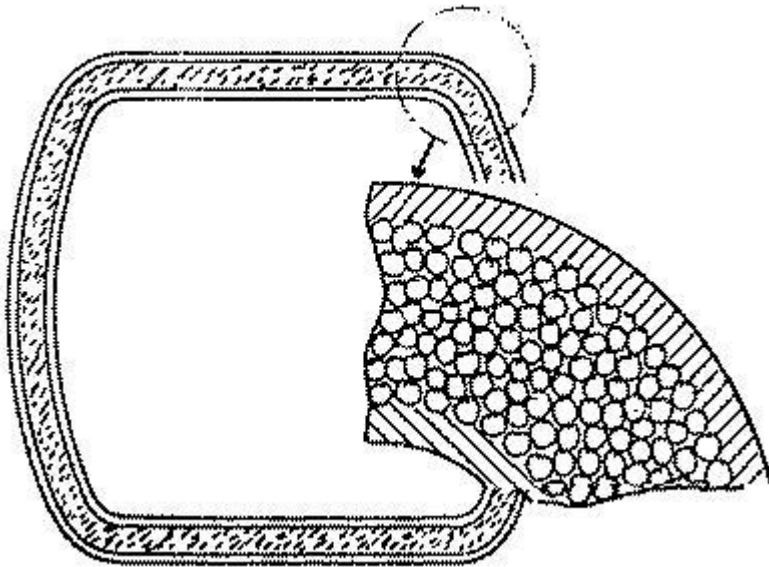

B65D 90/52

Anti-slosh devices (vehicle fuel tanks with means modifying or controlling distribution or motion of fuel, e.g. to prevent noise, surge, splash or fuel starvation [B60K 15/077](#))

Definition statement

This place covers:

Illustrative example of subject matter classified in this group:

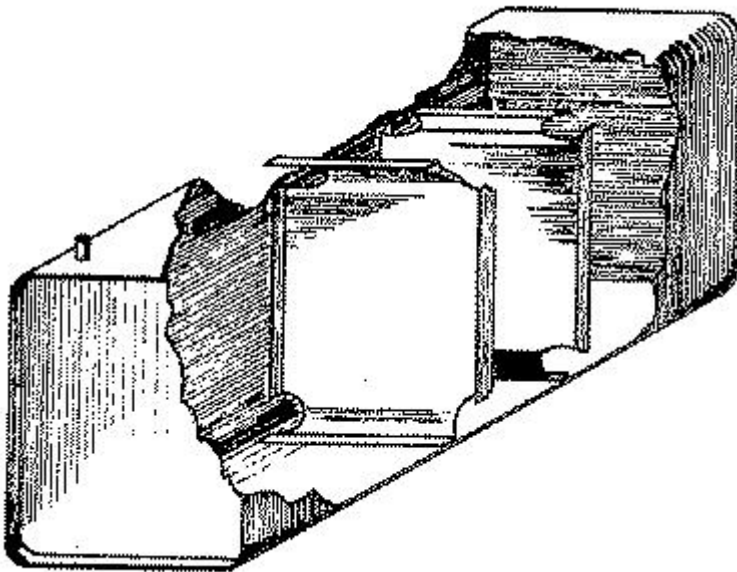

References

Limiting references

This place does not cover:

Partition	B65D 90/004
Fuel tank in vehicles	B60K 15/077
Tank vehicles	B60P 3/2235

B65D 90/54

Gates or closures (for manholes [B65D 90/10](#); covers or similar closure members, for pressure vessels in general [F16J 13/00](#); valves per se [F16K](#); {doors for containers [B65D 90/008](#)})

References

Limiting references

This place does not cover:

Pallet	B65D 2519/00805
Receptacle closures, covers or doors; Mechanisms for operating them	B01F 35/45

Limiting references

Controlling the operation of apparatus for producing mixtures of clay or cement with other substances; Supplying or proportioning the ingredients for mixing clay or cement with other substances; Discharging the mixture	B28C 7/00
Vehicles predominantly for transporting loads and modified to facilitate loading, consolidating the load, or unloading (the load-transporting element having bottom discharging openings)	B60P 1/56
Protecting against shocks	B60P 7/16
Nozzles, funnels, or guides (with flow cut-off means) for introducing articles or materials into containers or wrappers	B65B 39/001
Hopper for concrete including closures	E04G 21/025
Locking or latching means	E05B , E05C
Covers or similar closure members for pressure vessels in general	F16J 13/00
Means for automatically discharging weigh receptacles by valves or flaps in the container bottom	G01G 13/18

Special rules of classification

The use of available Indexing Codes is mandatory.

B65D 90/545

{Discharge end caps}

Definition statement

This place covers:

Illustrative example of subject matter classified in this group:

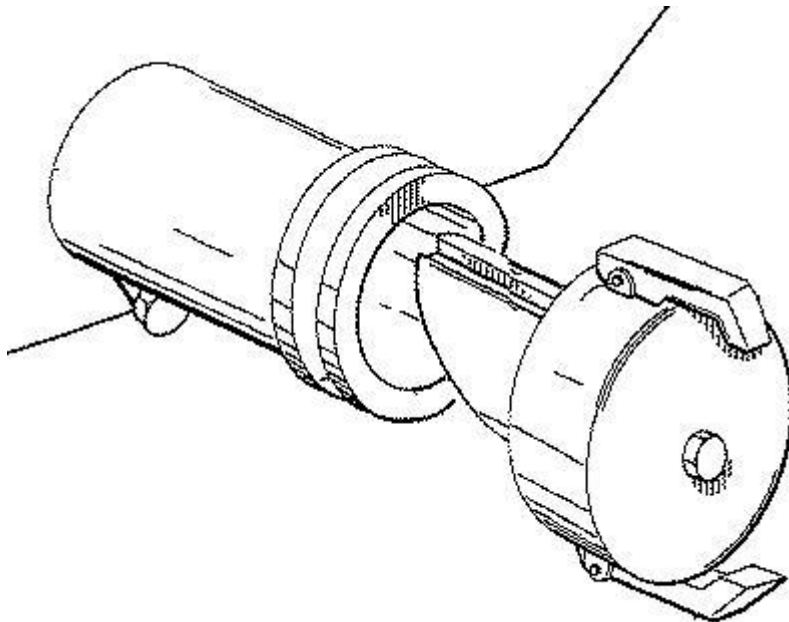

Special rules of classification

The use of available Indexing Codes is mandatory.

B65D 90/56

operating by deformation of flexible walls {([B65D 90/58](#) takes precedence)}

Definition statement

This place covers:

Illustrative example of subject matter classified in this group:

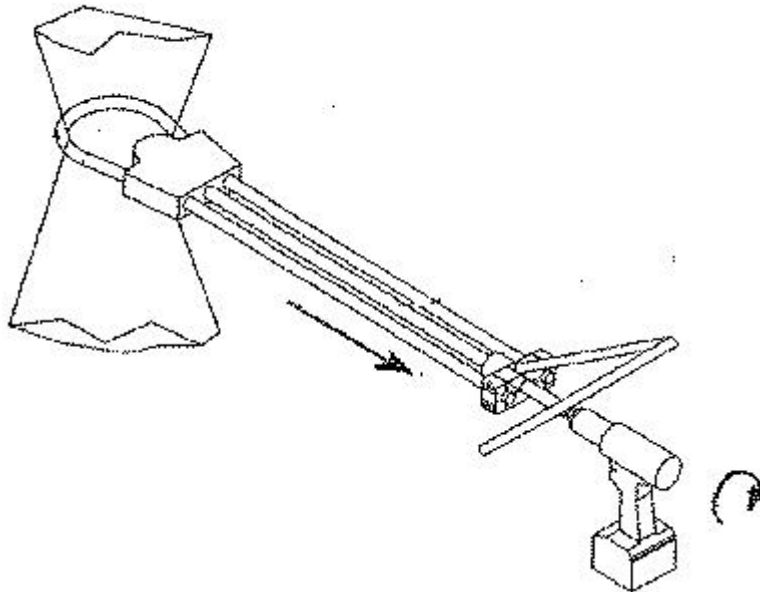
**References****Limiting references**

This place does not cover:

Having closure members sliding in the plane of the opening	B65D 90/58
Having closure members sliding in the plane of the opening	B65D 90/62

Informative references

Attention is drawn to the following places, which may be of interest for search:

Closures for top or bottom openings	B65D 88/1668
-------------------------------------	------------------------------

Special rules of classification

The use of available Indexing Codes is mandatory.

B65D 90/58

having closure members sliding in the plane of the opening

References

Informative references

Attention is drawn to the following places, which may be of interest for search:

Construction of housing of cutting-off parts of tanks	F16K 27/07
---	----------------------------

Special rules of classification

The use of available Indexing Codes is mandatory.

B65D 90/582

{having a rotational motion}

Definition statement

This place covers:

Illustrative example of subject matter classified in this group:

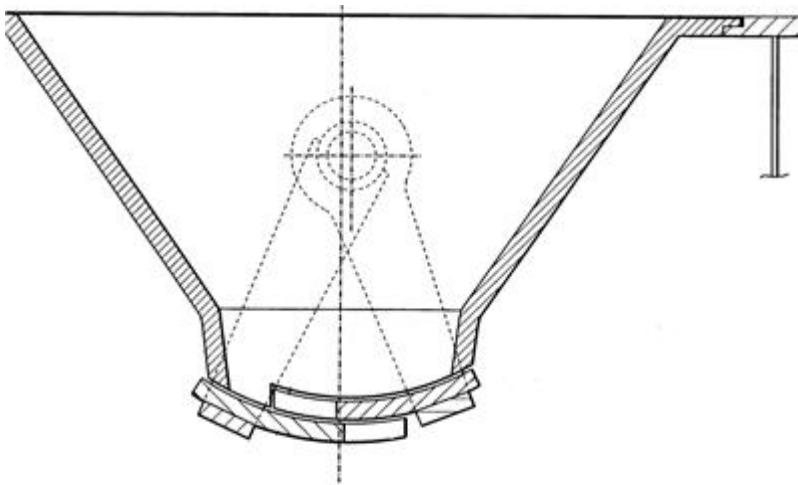

Special rules of classification

The use of available Indexing Codes is mandatory.

B65D 90/585

{around an axis perpendicular to the valve port}

Definition statement

This place covers:

Illustrative example of subject matter classified in this group:

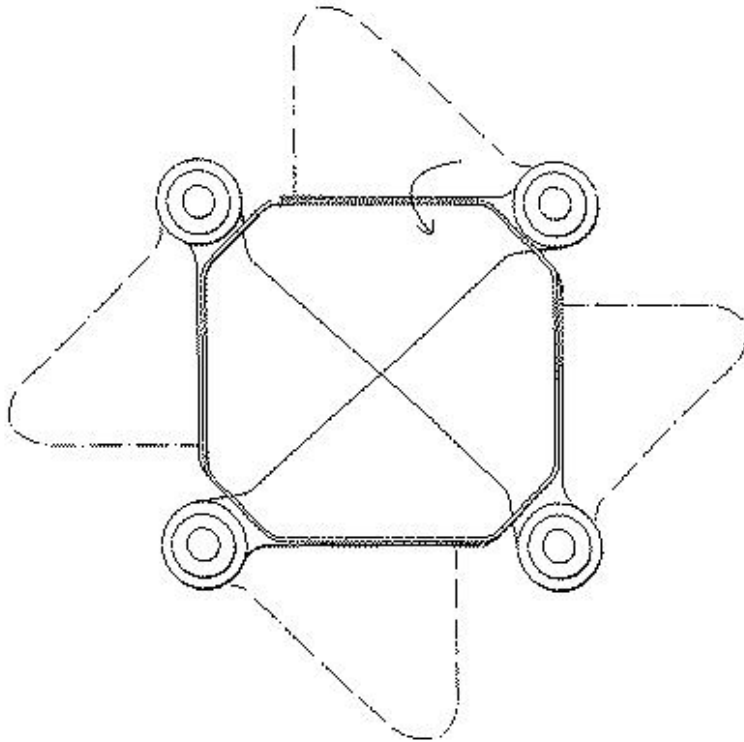

Special rules of classification

The use of available Indexing Codes is mandatory.

B65D 90/587

{having a linear motion}

Definition statement

This place covers:

Illustrative example of subject matter classified in this group:

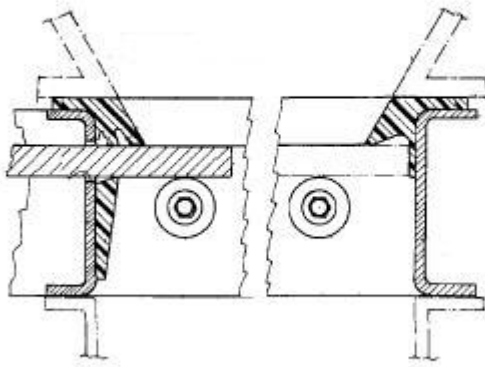

B65D 90/60

and having one or more openings

Definition statement

This place covers:

Illustrative example of subject matter classified in this group:

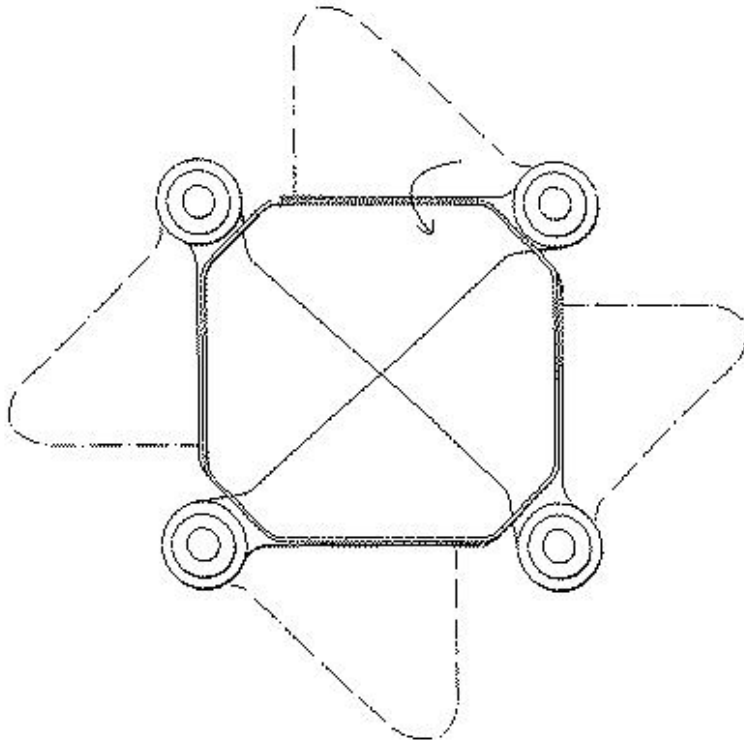

References

Informative references

Attention is drawn to the following places, which may be of interest for search:

Auxiliary measures taken, or devices used, in connection with loading or unloading: preventing escape of dust with co-operating closure members on each of the parts of a separable transfer channel	B65G 69/183
--	-----------------------------

Special rules of classification

Indexing Code [B65D 2590/547](#) can also be used.

The use of available Indexing Codes is mandatory.

B65D 90/62

having closure members movable out of the plane of the opening

References**Informative references**

Attention is drawn to the following places, which may be of interest for search:

Of cutting-off parts of tanks	F16K 27/07
-------------------------------	----------------------------

Special rules of classification

The use of available Indexing Codes is mandatory.

B65D 90/623

{having a rotational motion}

Definition statement

This place covers:

Illustrative examples of subject matter classified in this group:

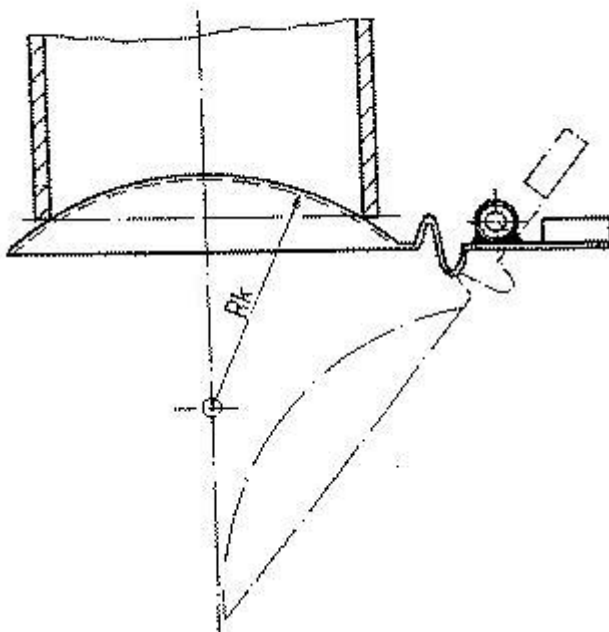
**References****Informative references**

Attention is drawn to the following places, which may be of interest for search:

By displacement of walls	B65G88/58
--------------------------	---------------------------

Special rules of classification

The use of available Indexing Codes is mandatory.

B65D 90/626

{having a linear motion}

Definition statement

This place covers:

Illustrative example of subject matter classified in this group:

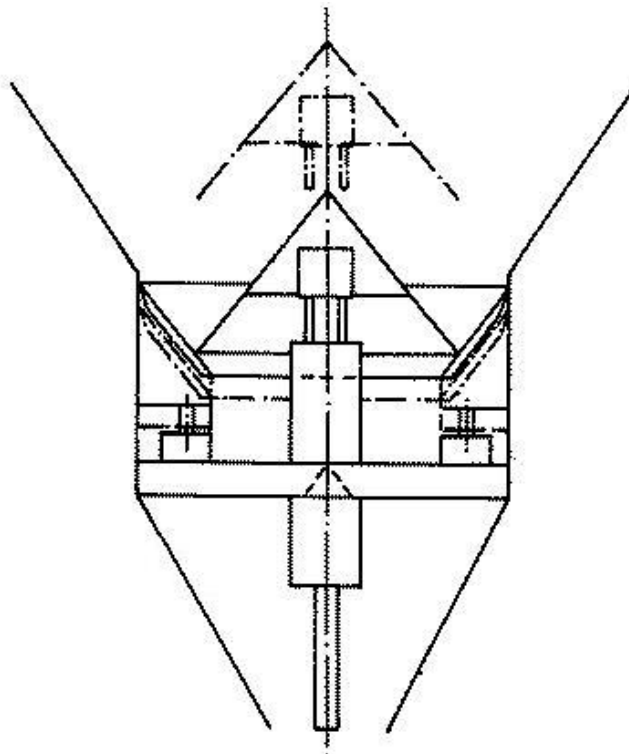

Special rules of classification

The use of available Indexing Codes is mandatory.

B65D 90/64

having multipart closure members, the parts being brought into closing position one by one according to need

Definition statement

This place covers:

Illustrative examples of subject matter classified in this group:

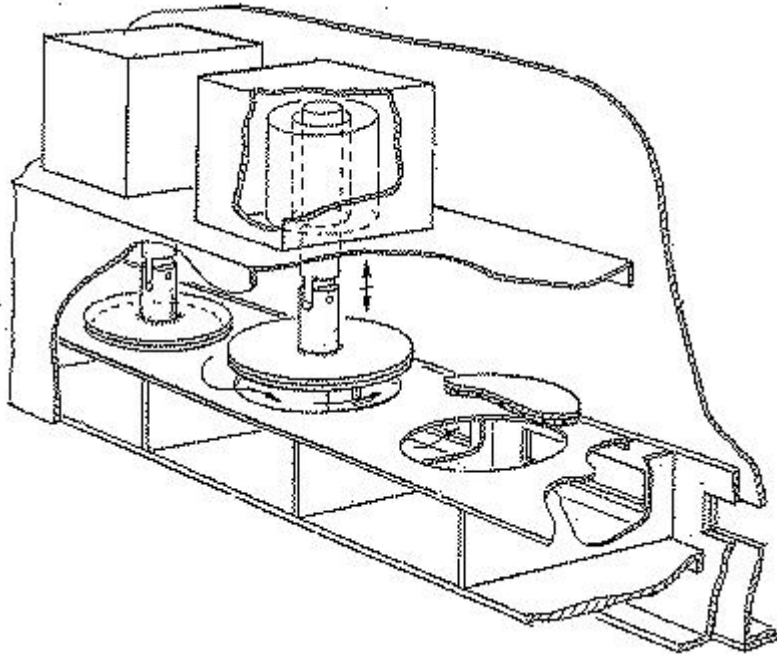

References

Informative references

Attention is drawn to the following places, which may be of interest for search:

Preventing escape of dust with co-operating closure members on each of the parts of a separable transfer channel	B65G 69/183
--	-----------------------------

Special rules of classification

Indexing Code [B65D 2590/547](#) can also be used.

The use of available Indexing Codes is mandatory.

B65D 90/66

Operating devices therefor

Special rules of classification

Always classify the movement of the gate, e.g. [B65D 90/58](#) or [B65D 90/62](#).

The use of available Indexing Codes is mandatory.

B65D 2201/00

Means or constructions for testing or controlling the contents

References

Informative references

Attention is drawn to the following places, which may be of interest for search:

Wrappers or flexible covers with provision for excluding or admitting light with some areas transparent and others opaque	B65D 65/18
Packages comprising articles or materials partially or wholly enclosed in strips, sheets, blanks, tubes, or webs of flexible sheet material with inspection openings or windows	B65D 75/522

B65D 2203/00

Decoration means, markings, information elements, contents indicators (see also [B65D 5/4212](#), [B65D 33/004](#))

References

Informative references

Attention is drawn to the following places, which may be of interest for search:

Containers of polygonal cross-section with information or decoration elements	B65D 5/4212
Details of, or accessories for, sacks or bags, information or decoration elements	B65D 33/004

B65D 2203/10

Transponders

References

Limiting references

This place does not cover:

Use of RFID in labelling machines	B65C 2009/0003
-----------------------------------	--------------------------------

B65D 2205/00

Venting means

References

Informative references

Attention is drawn to the following places, which may be of interest for search:

Ventilating arrangements	B65D 5/4295
Ventilation or drainage of bags	B65D 33/01

Closures with discharging devices other than pumps with means for venting	B65D 47/32
Closures with means for venting air or gas	B65D 51/16
Pressure relief-valves incorporated in a container wall	B65D 77/225

B65D 2205/02

Venting holes

References

Limiting references

This place does not cover:

Special constructions	B65D 51/1611
-----------------------	------------------------------

B65D 2207/00

Standing packages

References

Informative references

Attention is drawn to the following places, which may be of interest for search:

Standing pouches	B65D 75/008
------------------	-----------------------------

B65D 2209/00

Provisions for used articles

References

Limiting references

This place does not cover:

For dispensers of thin flat articles in succession	B65D 83/0888
Casings for collecting used medical articles	A61B 50/36

B65D 2211/00

Anti-theft means

References

Limiting references

This place does not cover:

Anti-theft devices, e.g. tags or monitors, fixed to articles	E05B 73/0017
Theft detection systems using tags	G08B 13/2402

Informative references

Attention is drawn to the following places, which may be of interest for search:

Tamper-indicating means	B65D 2401/00
-------------------------	------------------------------

B65D 2213/02

Means for preventing build-up of electrostatic charges

References**Limiting references**

This place does not cover:

For large containers	B65D 90/46
----------------------	----------------------------

B65D 2221/00

Small packaging specially adapted for product samples, single-use packages or échantillons

References**Informative references**

Attention is drawn to the following places, which may be of interest for search:

Containers having bodies formed in one piece made of flexible material	B65D 1/095
Casings or accessories for storing or handling solid or pasty toiletry or cosmetic substances for samples	A45D 40/0087

B65D 2231/022

for permitting the insertion of a tubular contents-removing device, e.g. a drinking straw

Definition statement

This place covers:

Illustrative example of subject matter classified in this group:

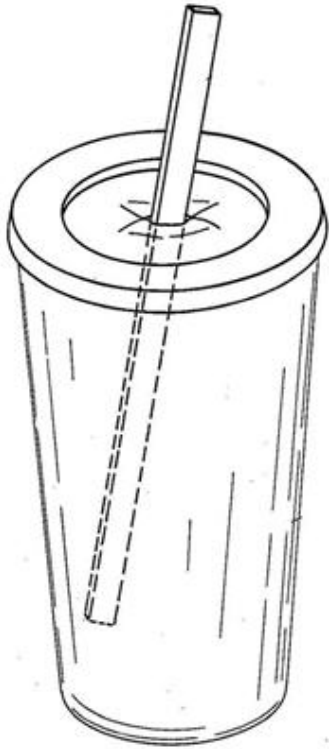
**References****Informative references**

Attention is drawn to the following places, which may be of interest for search:

Closures to be pierced by an extracting-device for the contents and fixed on the container by separate retaining means	B65D 51/002
--	-----------------------------

B65D 2231/025

for draining or discharging the liquid contents, e.g. soup, milk

Definition statement

This place covers:

Illustrative example of subject matter classified in this group:

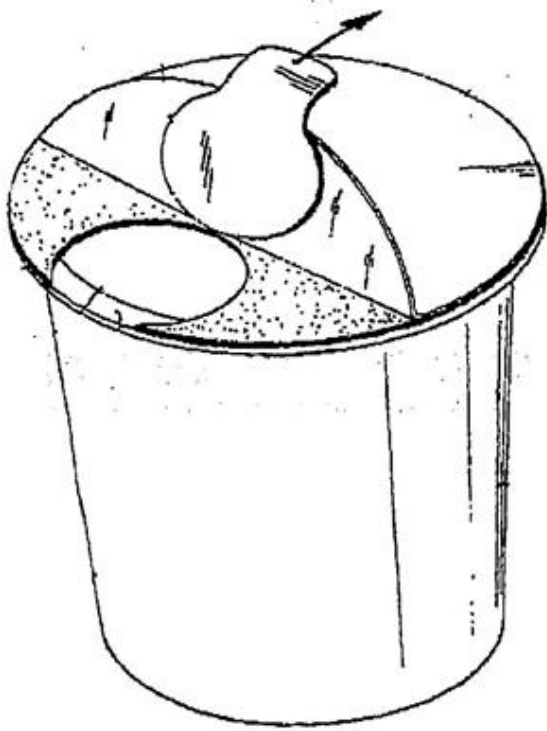

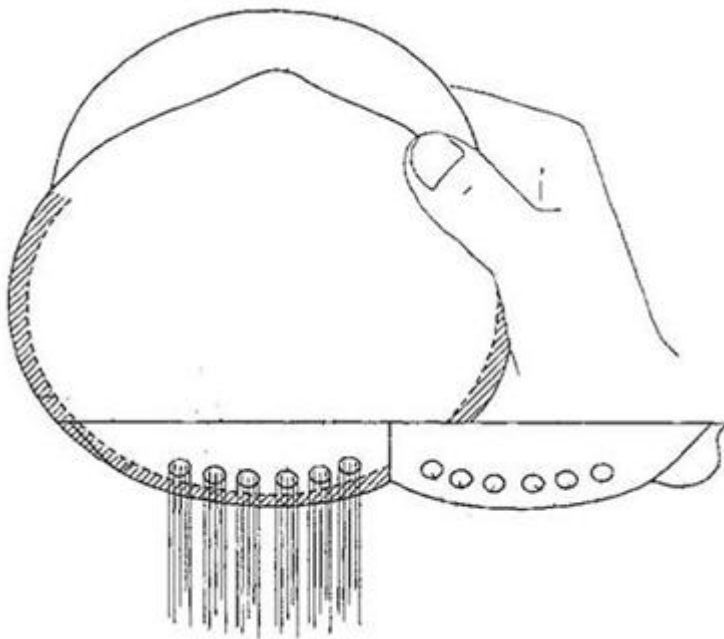
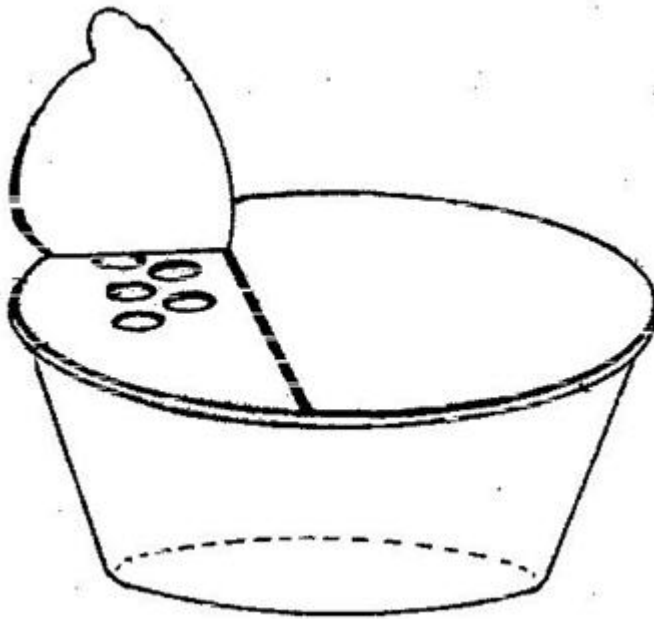

References

Informative references

Attention is drawn to the following places, which may be of interest for search:

Lines of weakness or apertures in cover	B65D 2577/2091
---	--------------------------------

B65D 2231/027

for discharging a solidified or gelatinous products, e.g. pudding, ice-cream, from the package

Definition statement

This place covers:

Illustrative example of subject matter classified in this group:

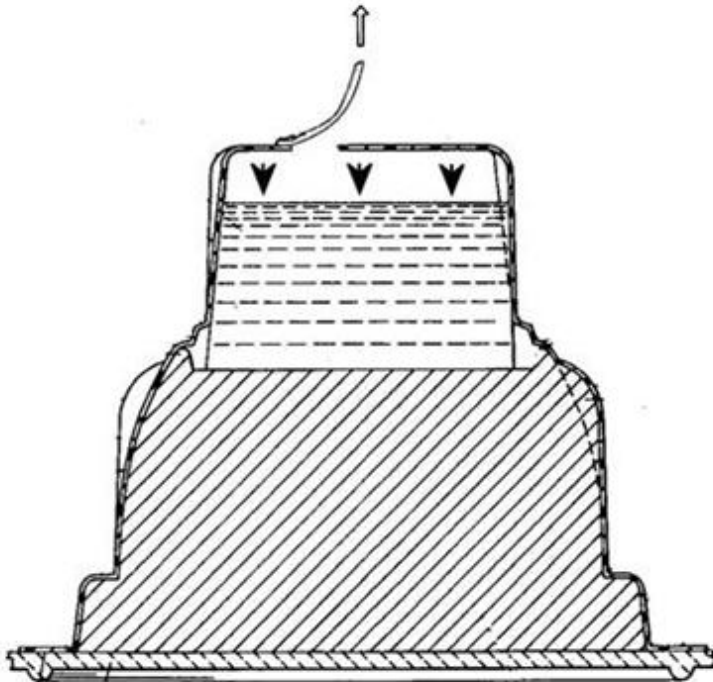
**B65D 2251/00**

Details relating to container closures (lids or covers for box-like containers [B65D 43/00](#); see also [B65D 43/00](#))

References**Limiting references**

This place does not cover:

Lids or covers for box-like containers	B65D 2543/00
--	------------------------------

B65D 2251/0003

Two or more closures

Relationships with other classification places

The [B65D 2251/0003](#) codes are to be used with the [B65D 51/18](#), [B65D 51/185](#) and [B65D 51/20](#) groups.

B65D 2251/01**making a sound upon actuation****References****Informative references***Attention is drawn to the following places, which may be of interest for search:*

Closures, being provided with transient audible or visual signaling means	B65D 51/248
---	-----------------------------

B65D 2251/04**Orienting or positioning means****References****Limiting references***This place does not cover:*

Threaded caps	B65D 41/0471
---------------	------------------------------

Informative references*Attention is drawn to the following places, which may be of interest for search:*

Orienting or positioning means for containers	B65D 2303/00
---	------------------------------

B65D 2251/06**Special configurations; Closures simulating or provided with another item, e.g. puppet, animal, vehicle, building ([B65D 81/366](#) takes precedence)****References****Informative references***Attention is drawn to the following places, which may be of interest for search:*

Containers, or parts thereof, simulating or being incorporated into other items, the container closure only being provided with a three dimensional figure	B65D 81/366
--	-----------------------------

B65D 2251/065**the external skirt having a non-circular cross-section, e.g. square, elliptical****References****Informative references***Attention is drawn to the following places, which may be of interest for search:*

Shape of the outer periphery	B65D 2543/00064
------------------------------	---------------------------------

B65D 2251/07

Closures specially adapted for closing bottle-necks of non-circular cross-section

References**Informative references**

Attention is drawn to the following places, which may be of interest for search:

Necks of non-circular cross-section	B65D 2501/009
-------------------------------------	-------------------------------

B65D 2251/08

Closures specially adapted for closing container mouths of differing size or configuration, e.g. screw/snap combination

References**Informative references**

Attention is drawn to the following places, which may be of interest for search:

Multi-position closures	B65D 2543/0025
-------------------------	--------------------------------

B65D 2251/1008

Means for locking the closure in open position

References**Informative references**

Attention is drawn to the following places, which may be of interest for search:

Devices for retaining in open position	B65D 43/24
--	----------------------------

B65D 2251/1016

Means for locking the closure in closed position

References**Limiting references**

This place does not cover:

Anti-theft means	B65D 2211/00
Child-proof means	B65D 2215/00
Tamper-indicating means	B65D 2401/00

Informative references

Attention is drawn to the following places, which may be of interest for search:

Devices for holding in closed position	B65D 43/22
--	----------------------------

B65D 2251/20

Sealing means

References

Limiting references

This place does not cover:

For box-like containers	B65D 2543/00953
-------------------------	---------------------------------

B65D 2251/205

Inserted

References

Limiting references

This place does not cover:

For box-like containers	B65D 2543/00962
-------------------------	---------------------------------

B65D 2275/02

Sheets wrappers or bags provided with protective or puncture resistant patches, specially adapted for meat on the bone, e.g. patch bags

Definition statement

This place covers:

Illustrative example of subject matter classified in this group:

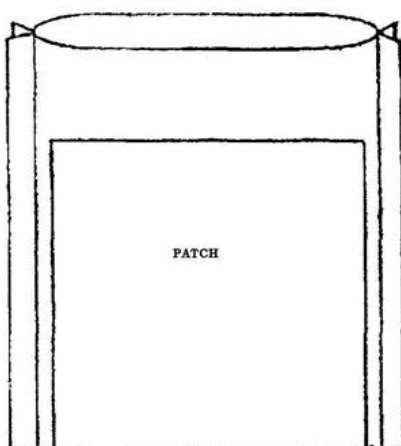

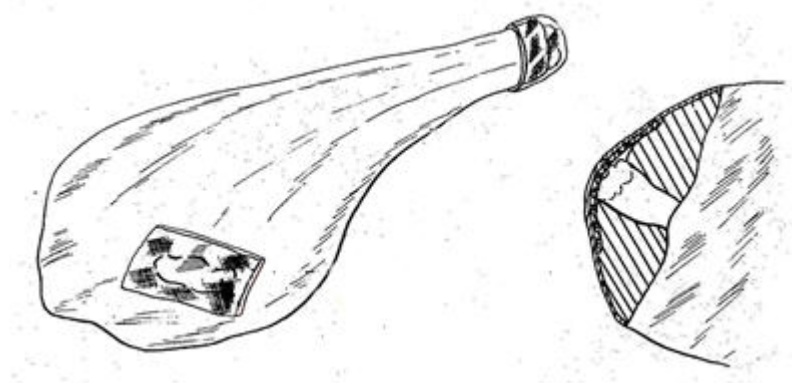

B65D 2301/10

Blanks mutually positioned to minimise waste material upon cutting out the individual blank from a continuous or large sheet

Definition statement

This place covers:

Illustrative example of subject matter classified in this group:

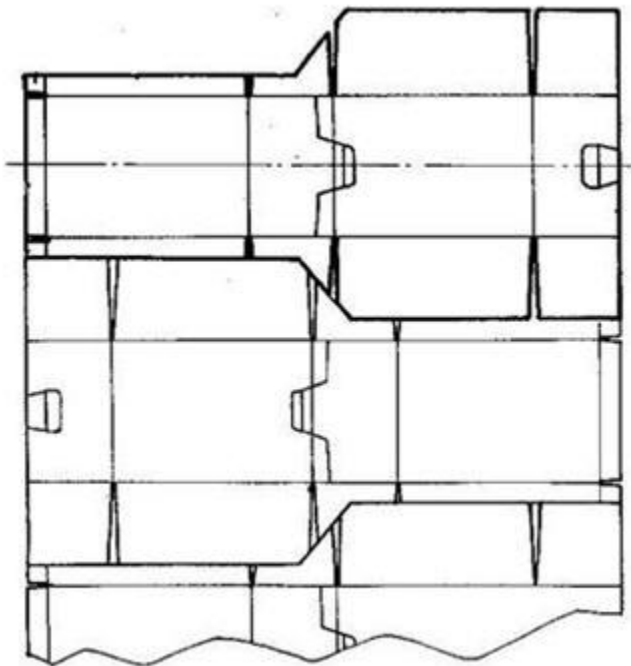

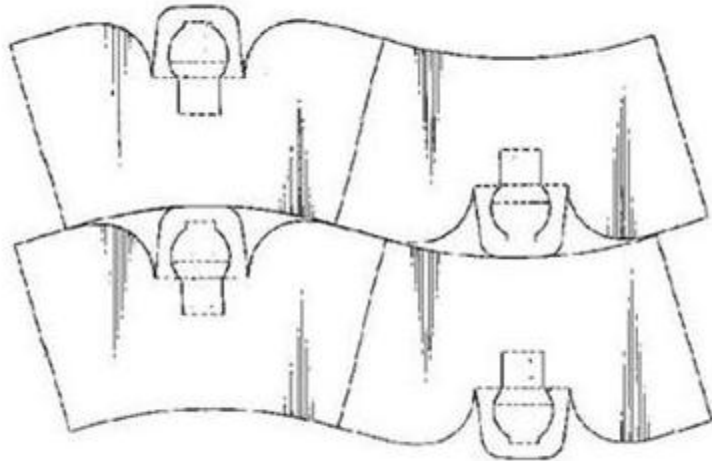

B65D 2303/00

Orienting or positioning means for containers

Definition statement

This place covers:

Illustrative example of subject matter classified in this group:

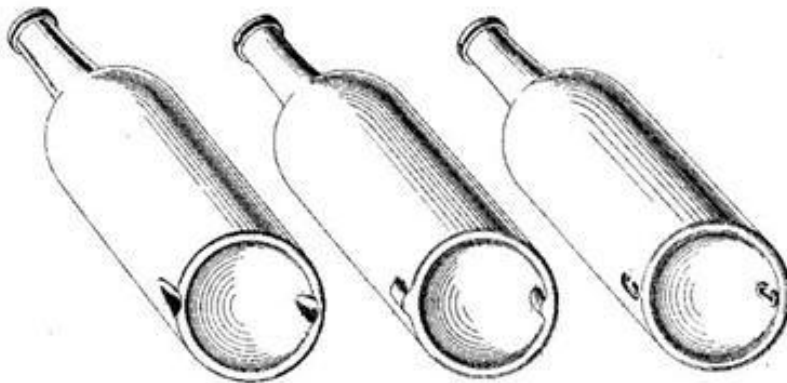

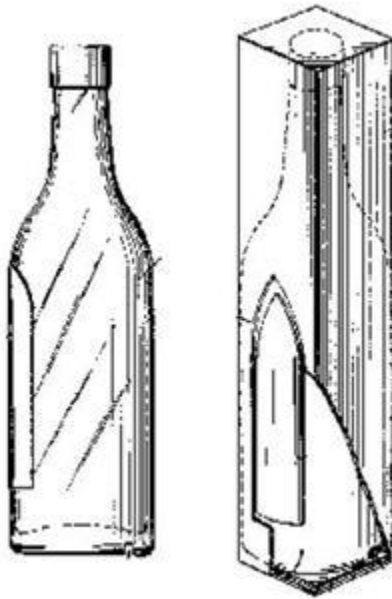

References

Informative references

Attention is drawn to the following places, which may be of interest for search:

Orienting or positioning means	B65D 2251/04
--------------------------------	------------------------------

B65D 2313/02

of hook-and-loop type

Definition statement

This place covers:

Illustrative example of subject matter classified in this group:

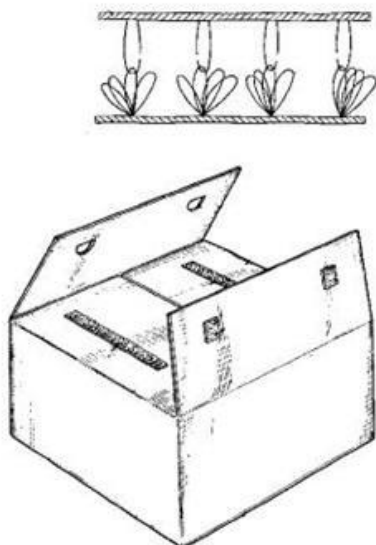

B65D 2313/04**of magnetic type****Definition statement***This place covers:*

Illustrative example of subject matter classified in this group:

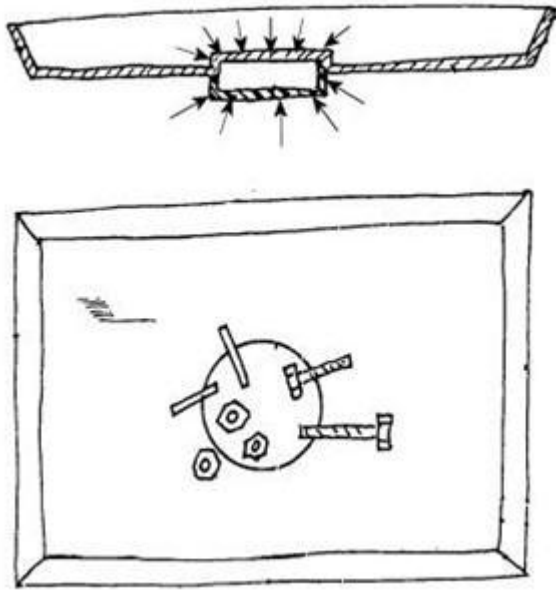
**References****Limiting references***This place does not cover:*

Magnetic connections for lids or covers	B65D 77/20
---	----------------------------

B65D 2313/06**using vacuum suction cups****Definition statement***This place covers:*

Illustrative example of subject matter classified in this group:

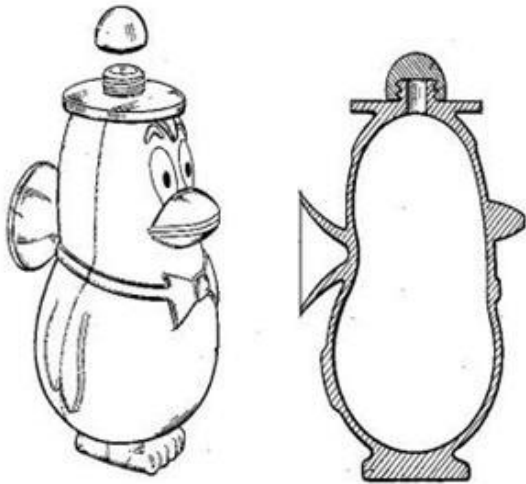
**References****Limiting references***This place does not cover:*

Suction cups for attaching purposes	F16B 47/00
-------------------------------------	----------------------------

B65D 2313/08

Double sided adhesive tape, e.g. for suspension of the container (**B65D 2313/10** takes precedence)

Definition statement

This place covers:

Illustrative example of subject matter classified in this group:

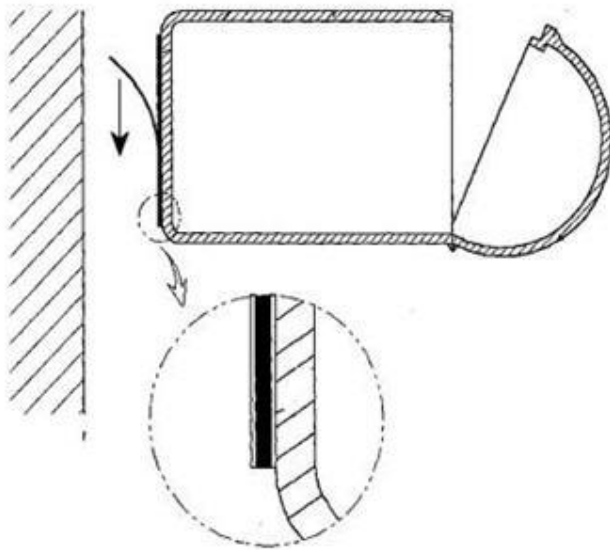
**References****Informative references**

Attention is drawn to the following places, which may be of interest for search:

Adhesive tapes	B65D 63/1009
----------------	------------------------------

B65D 2313/10

Adhesive or cohesive means for holding the contents attached to the container

References**Informative references**

Attention is drawn to the following places, which may be of interest for search:

Packaging elements adhered to the articles	B65D 71/0085
Locating elements for the contents the articles being glued to the wrapper	B65D 2571/00327

B65D 2401/00

Tamper-indicating means (relating to aerosol containers [B65D 83/224](#))

References**Limiting references**

This place does not cover:

Relating to aerosol containers	B65D 83/224
--------------------------------	-----------------------------

Informative references

Attention is drawn to the following places, which may be of interest for search:

Closures with special means for indicating unauthorised opening	B65D 27/30
End- or aperture-closing arrangements or devices with special means for indicating unauthorised opening	B65D 33/34
Caps or cap-like covers with lines of weakness, tearing-strips, tags, or like opening or removal devices	B65D 41/32
Arrangements or devices for preventing refilling of containers	B65D 49/00
Locking devices; Means for discouraging or indicating unauthorised opening or removal of closure	B65D 55/02
Anti-theft means	B65D 2211/00

B65D 2401/05

Tearable non-integral strips

References**Informative references**

Attention is drawn to the following places, which may be of interest for search:

Non-integral frangible members applied to, or inserted in, a preformed opening	B65D 17/50
--	----------------------------

B65D 2401/15

Tearable part of the closure ([B65D 2401/60](#) takes precedence)

References**Limiting references**

This place does not cover:

If combined with tearable part of the container	B65D 2401/60
---	------------------------------

Informative references

Attention is drawn to the following places, which may be of interest for search:

Closures in which a part has to be ruptured to gain access to the contents	B65D 55/024
--	-----------------------------

B65D 2401/20

Frangible elements completely enclosed in closure skirt (tear-off strips
[B65D 2401/25](#))

References**Limiting references**

This place does not cover:

Tear-off strips	B65D 2401/25
-----------------	------------------------------

Informative references

Attention is drawn to the following places, which may be of interest for search:

Annular elements encircling container necks	B65D 55/08
---	----------------------------

B65D 2401/60

Tearable part both of the container and of the closure

References**Informative references**

Attention is drawn to the following places, which may be of interest for search:

Tearable part of the container or of the closure	B65D 2401/10 , B65D 2401/15
--	--

B65D 2501/0018

Ribs

Definition statement

This place covers:

Illustrative example of subject matter classified in this group:

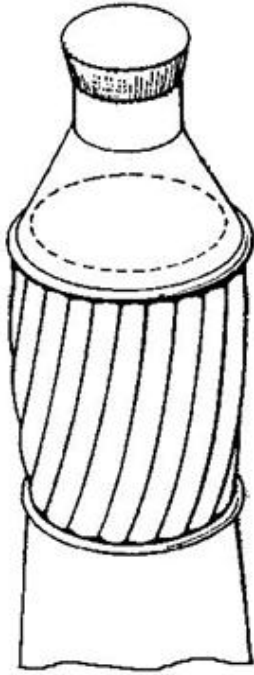

B65D 2501/0027

Hollow longitudinal ribs

Definition statement

This place covers:

Illustrative example of subject matter classified in this group:

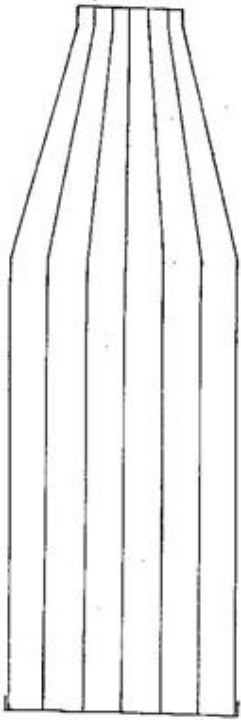

B65D 2501/0036

Hollow circumferential ribs

Definition statement

This place covers:

Illustrative example of subject matter classified in this group:

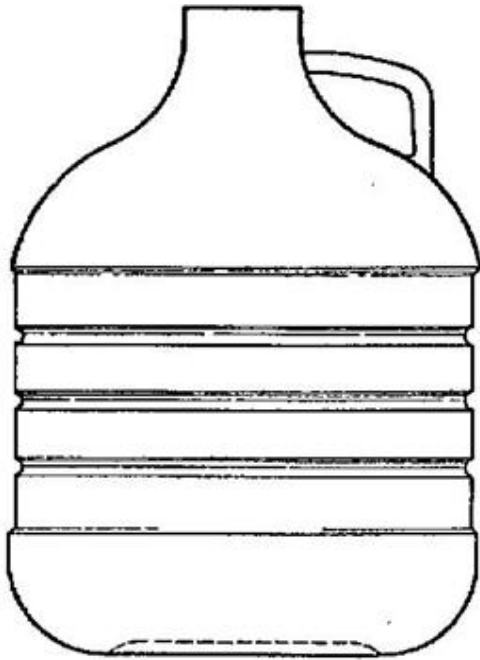

B65D 2501/0045

Solid ribs

Definition statement

This place covers:

Illustrative example of subject matter classified in this group:

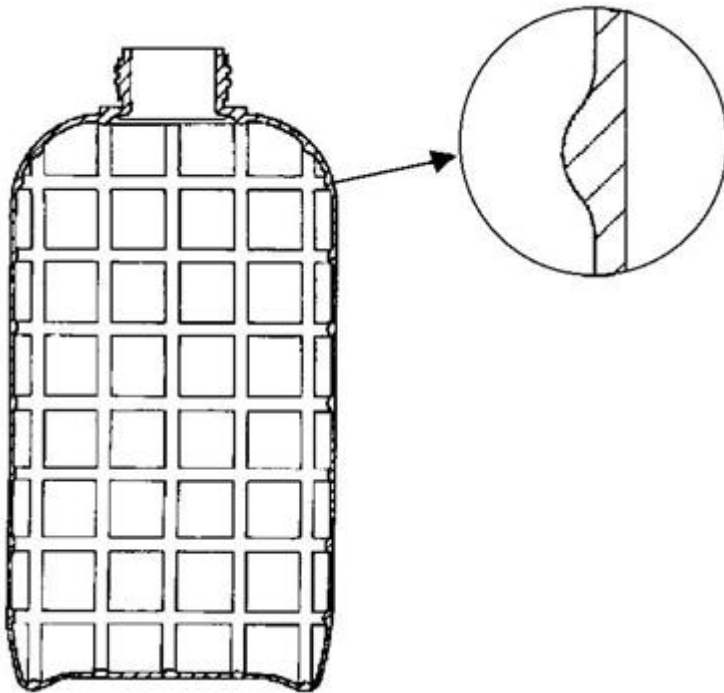

B65D 2501/0054

Lines of weakness

Definition statement

This place covers:

Illustrative example of subject matter classified in this group:

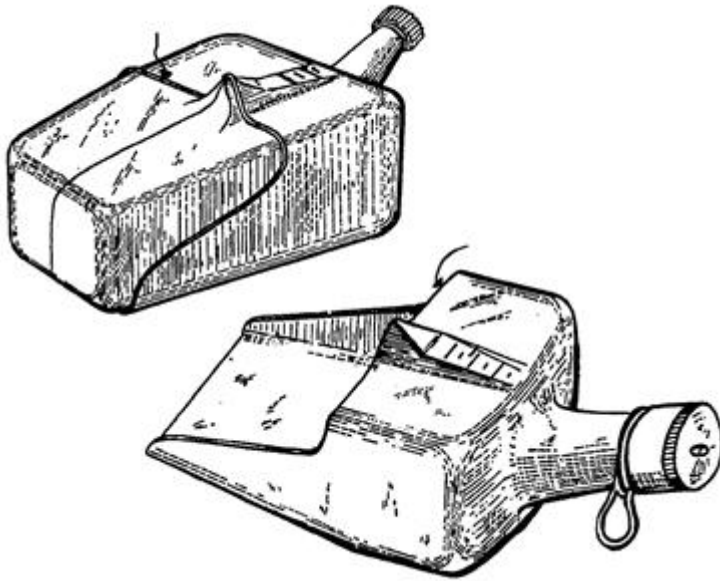

B65D 2501/0063

Additional discharging means ([B65D 1/06](#) takes precedence)

Definition statement

This place covers:

Illustrative example of subject matter classified in this group:

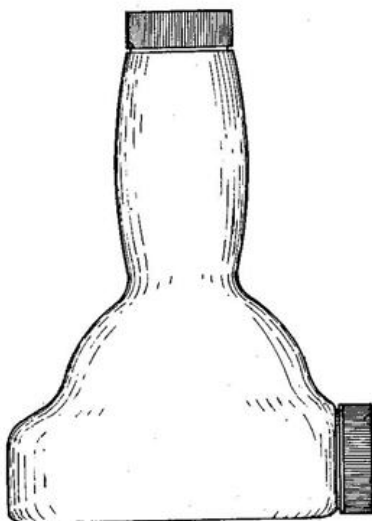

References

Limiting references

This place does not cover:

Bottles or similar containers with necks or like restricted apertures, designed for pouring contents with closable apertures at bottom	B65D 1/06
--	---------------------------

B65D 2501/0072

Means for facilitating filling of the bottle

Definition statement

This place covers:

Illustrative example of subject matter classified in this group:

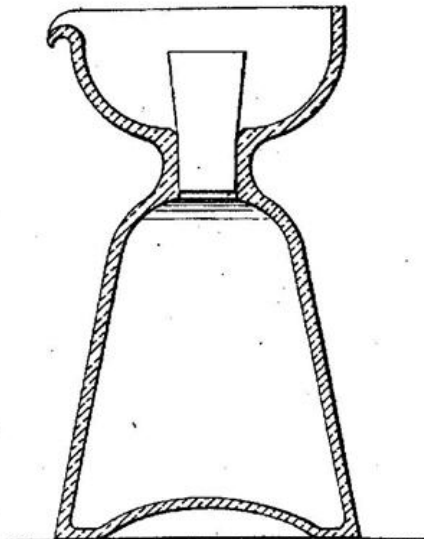

B65D 2501/0081

Bottles of non-circular cross-section

Definition statement

This place covers:

Illustrative example of subject matter classified in this group:

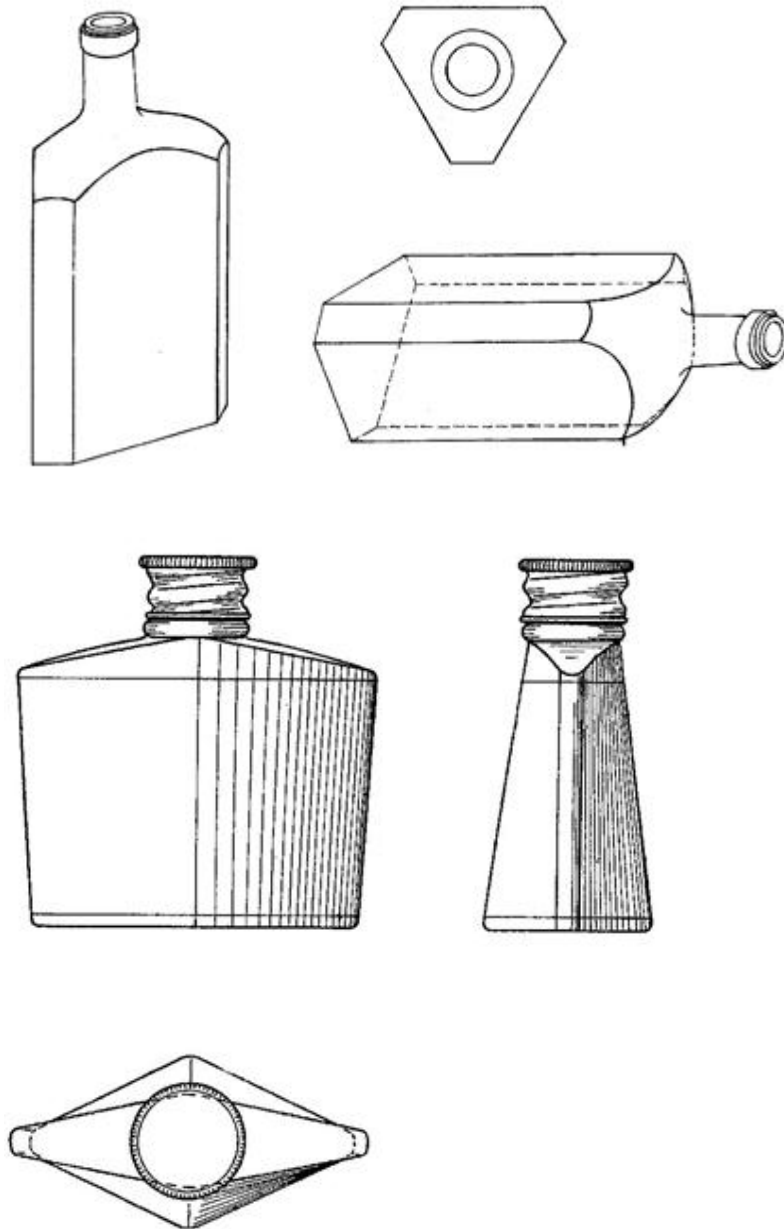

B65D 2501/009**Necks of non-circular cross-section****Definition statement**

This place covers:

Illustrative example of subject matter classified in this group:

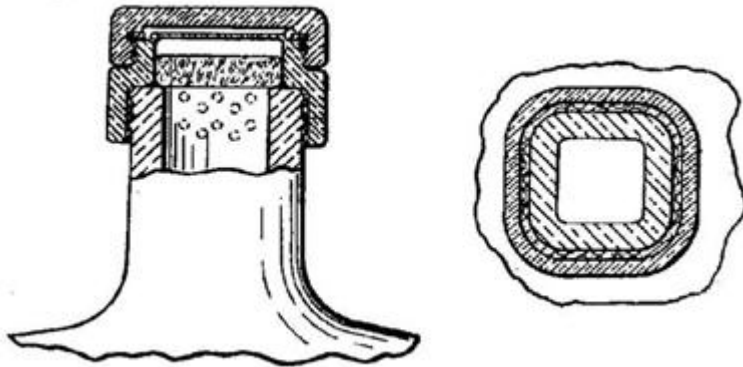
**References****Informative references**

Attention is drawn to the following places, which may be of interest for search:

Closures specially adapted for closing bottle-necks of non-circular cross-section	B65D 2251/07
---	------------------------------

B65D 2501/24363**Handles****References****Informative references**

Attention is drawn to the following places, which may be of interest for search:

Handles	B65D 25/28
---------	----------------------------

B65D 2501/2491**Transponders****References****Informative references**

Attention is drawn to the following places, which may be of interest for search:

Transponders	B65D 2203/10
--------------	------------------------------

B65D 2517/0005

and also in top wall

Definition statement

This place covers:

Illustrative example of subject matter classified in this group:

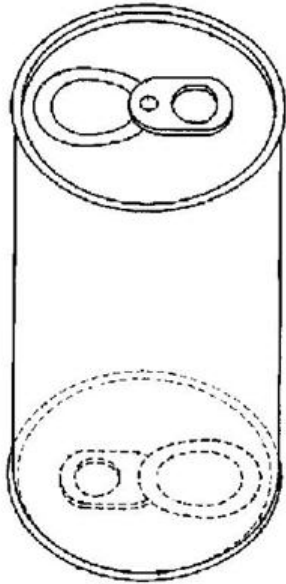

B65D 2517/0007
in a separate cover

Definition statement

This place covers:

Illustrative example of subject matter classified in this group:



References

Informative references

Attention is drawn to the following places, which may be of interest for search:

Caps	B65D 41/00
Lids or covers for rigid or semi-rigid containers	B65D 43/00
Closures not otherwise provided for	B65D 51/00

B65D 2517/0008

in side wall

Definition statement

This place covers:

Illustrative example of subject matter classified in this group:

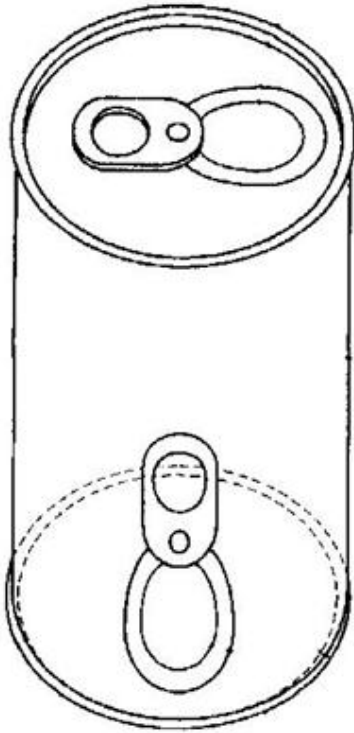

B65D 2517/0011

push-down tear panel

Definition statement

This place covers:

Illustrative example of subject matter classified in this group:

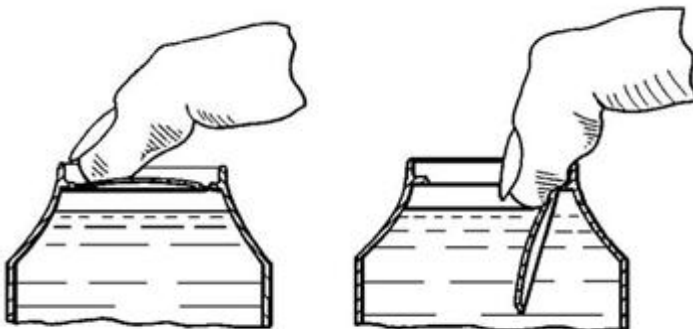

B65D 2517/0013

pull-out tear panel, e.g. by means of a tear-tab

Definition statement

This place covers:

Illustrative example of subject matter classified in this group:

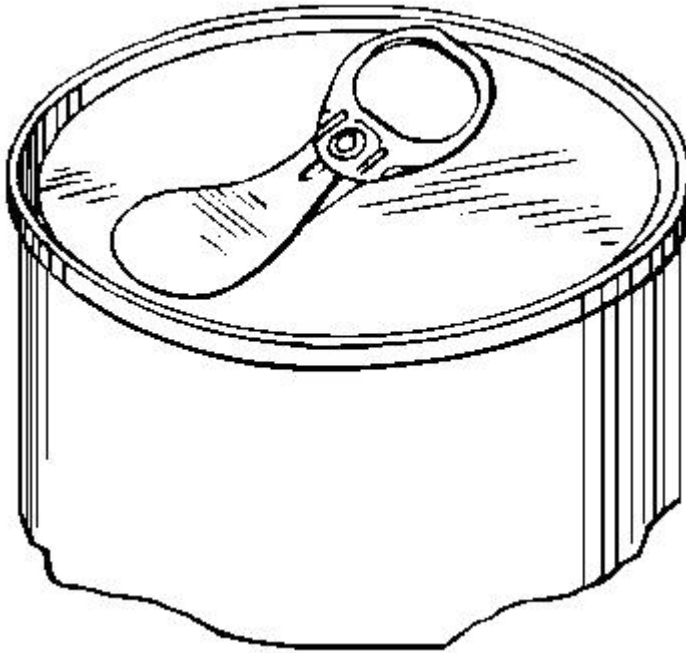

B65D 2517/0014

pivot tab and push-down tear panel

Definition statement

This place covers:

Illustrative example of subject matter classified in this group:

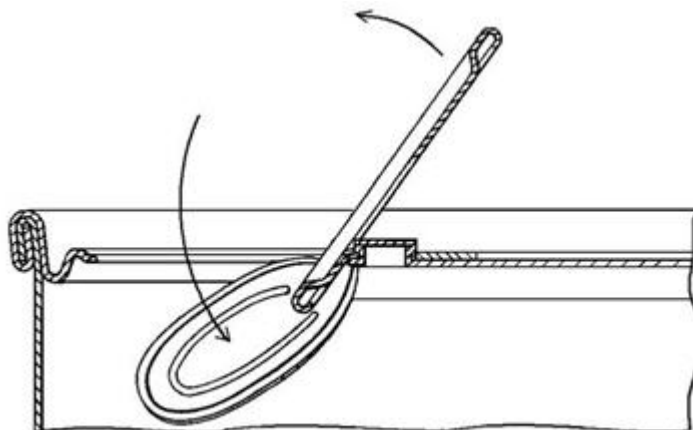

B65D 2517/0016**pivot tab, push-down and pull-out tear panel****Definition statement**

This place covers:

Illustrative example of subject matter classified in this group:

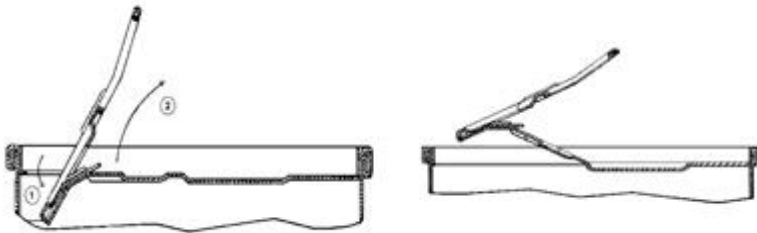
**B65D 2517/0017****linearly sliding tear panel****Definition statement**

This place covers:

Illustrative example of subject matter classified in this group:

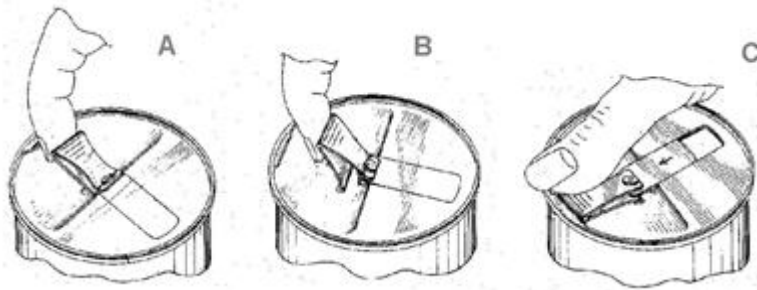
**References****Informative references**

Attention is drawn to the following places, which may be of interest for search:

Reclosable openings, the tab and torn out panel together closing the opening	B65D 2517/0035
--	--------------------------------

B65D 2517/0019

Tear panel rolled about the tab

Definition statement

This place covers:

Illustrative example of subject matter classified in this group:

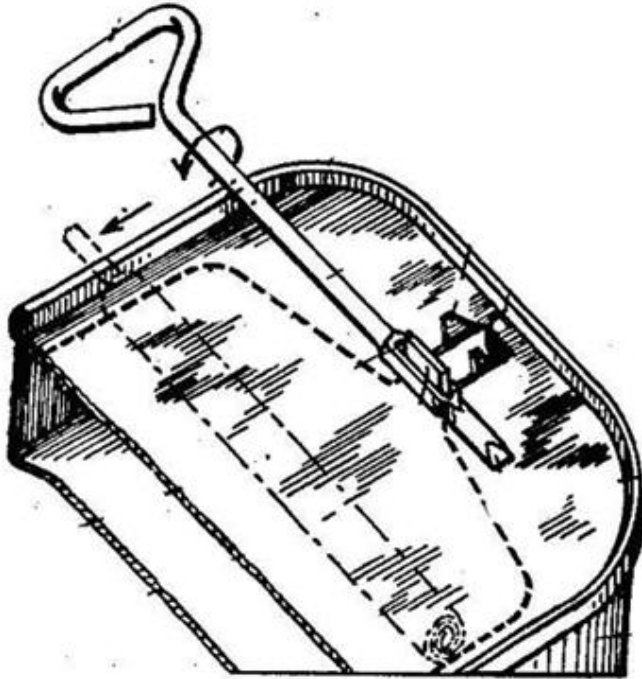

References

Informative references

Attention is drawn to the following places, which may be of interest for search:

Tearing-strips or -wire with tongues or tags for engagement by slotted keys	B65D 17/464
---	-----------------------------

B65D 2517/0023

formed as part of the tab and moved into position

Definition statement

This place covers:

Illustrative example of subject matter classified in this group:

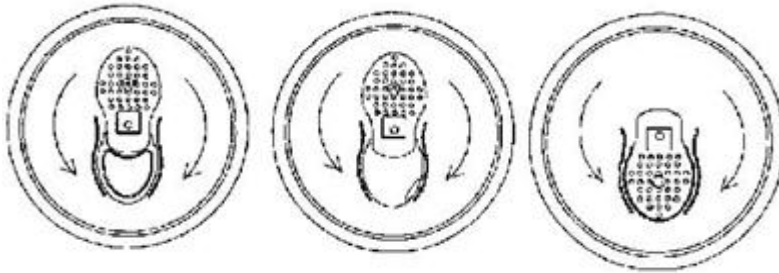

B65D 2517/0025

connected to the rivet and rotated into position, but formed separately from the tab

Definition statement

This place covers:

Illustrative example of subject matter classified in this group:

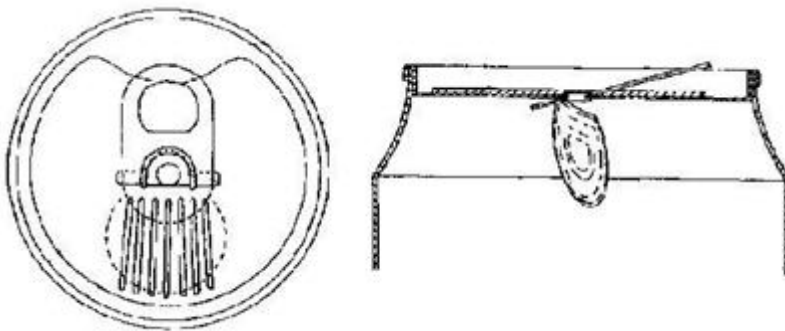

B65D 2517/0028

the element being part of the tab

Definition statement

This place covers:

Illustrative example of subject matter classified in this group:

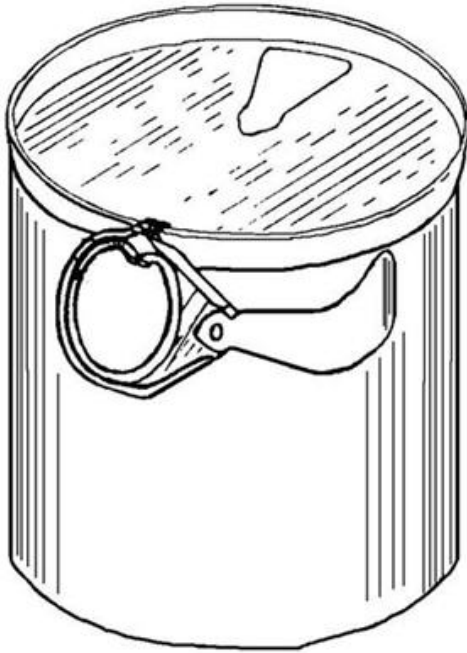

B65D 2517/0029

the element being part of the pull-out panel

Definition statement

This place covers:

Illustrative example of subject matter classified in this group:

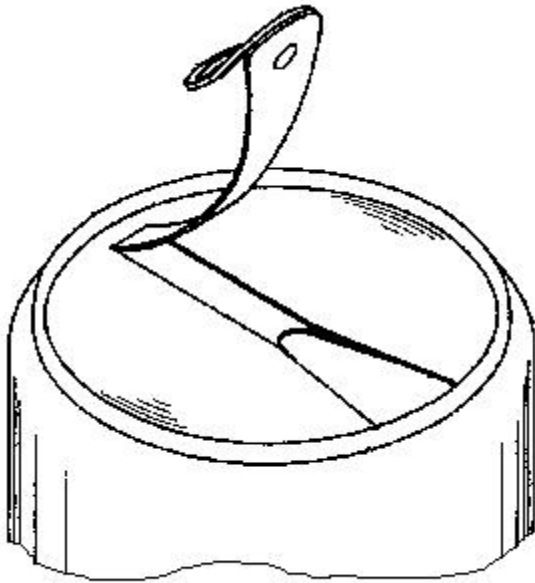

B65D 2517/0034

by means of the hand grip alone, e.g. rotating hand grip into opening

Definition statement

This place covers:

Illustrative example of subject matter classified in this group:

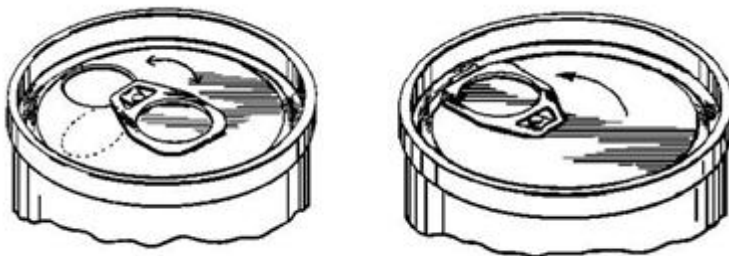

B65D 2517/0035

the tab and torn out panel together closing the opening, e.g. by sliding

Definition statement

This place covers:

Illustrative example of subject matter classified in this group:

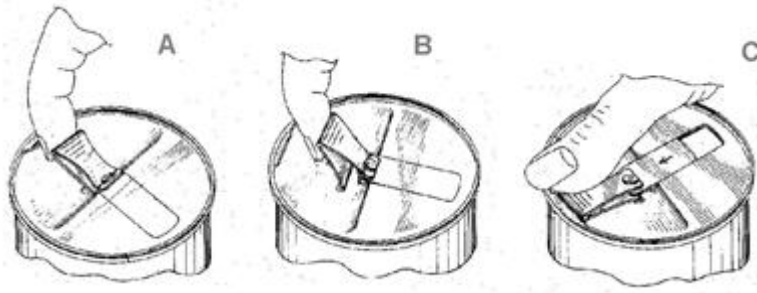
**References****Informative references**

Attention is drawn to the following places, which may be of interest for search:

Action for opening container linearly sliding tear panel	B65D 2517/0017
--	--------------------------------

B65D 2517/0038

the plug being reinsertable into the opening

Definition statement

This place covers:

Illustrative example of subject matter classified in this group:

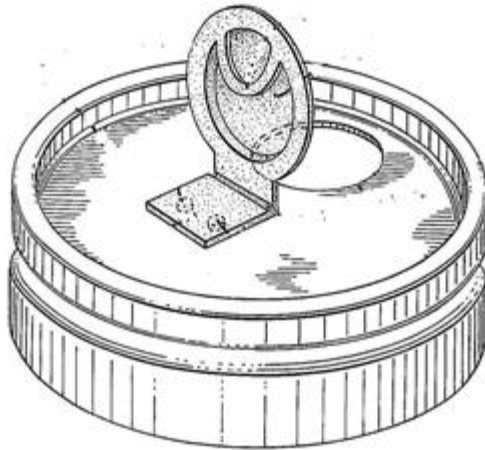
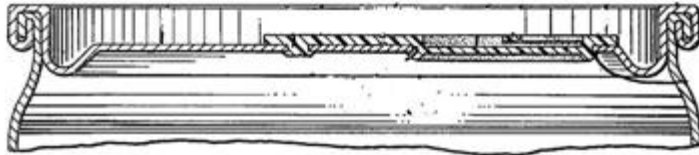
**References****Informative references**

Attention is drawn to the following places, which may be of interest for search:

Rigid or semi-rigid members	B65D 17/506
Separate closure devices for reclosing opened cans or tins	B65D 51/007
Reclosable openings in the form of a plug	B65D 2517/0043

B65D 2517/0041

in the form of a cover

Definition statement

This place covers:

Illustrative example of subject matter classified in this group:

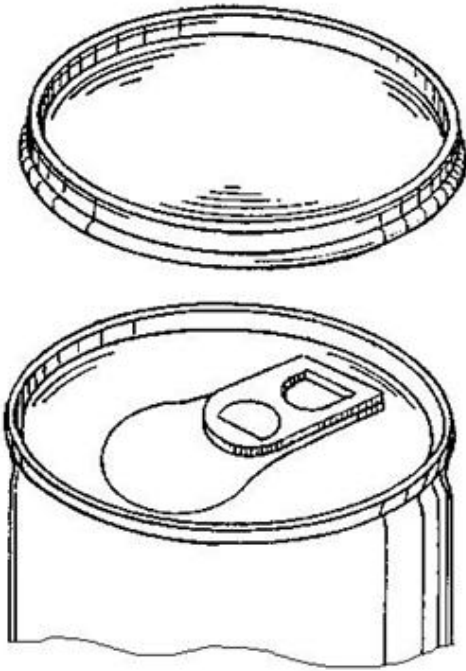
**B65D 2517/0043**

in the form of a plug

References***Informative references***

Attention is drawn to the following places, which may be of interest for search:

Rigid or semi-rigid members	B65D 17/506
Separate closure devices for reclosing opened cans or tins	B65D 51/007
Reclosable openings the plug being reinsertable into the opening	B65D 2517/0038

B65D 2517/0044**attached to the tear tab****Definition statement***This place covers:*

Illustrative example of subject matter classified in this group:

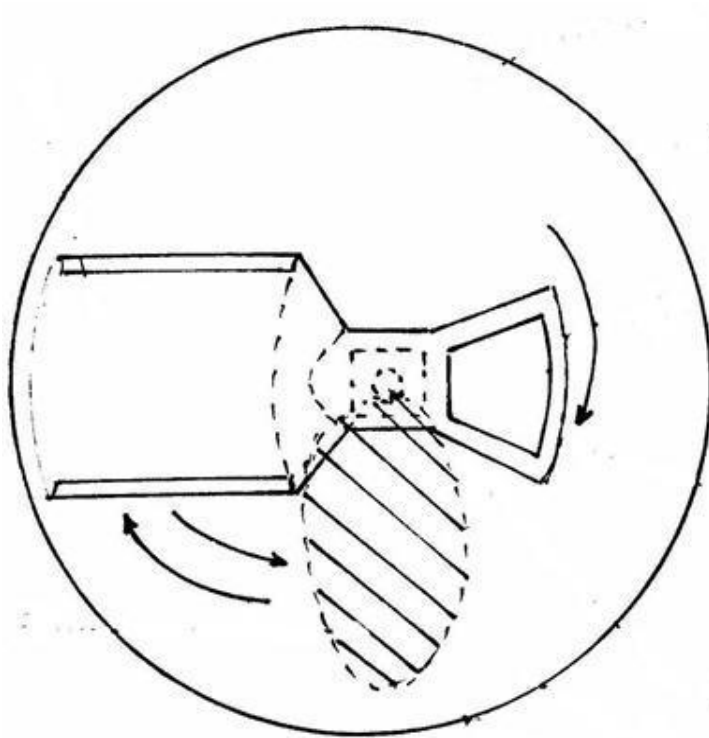
**B65D 2517/0049****Straws, spouts, funnels, or other devices facilitating pouring or emptying****References****Limiting references***This place does not cover:*

Means for preventing dust contacting pouring opening	B65D 2517/0098
--	--------------------------------

B65D 2517/005**formed as part of the tab****References****Informative references***Attention is drawn to the following places, which may be of interest for search:*

Closures with swivelling dispensing devices	B65D 47/046
---	-----------------------------

B65D 2517/0052

Prizes, tokens, badges or other information carrying devices

References

Informative references

Attention is drawn to the following places, which may be of interest for search:

Closures provided with decoration, information or contents indicating devices, labels	B65D 51/245
---	-----------------------------

B65D 2517/0058

Other details of container end panel

Special rules of classification

If no information given or if end panel is made of metal then no code is necessary

B65D 2517/0059

General cross-sectional shape of container end panel

Definition statement

This place covers:

Illustrative example of subject matter classified in this group:

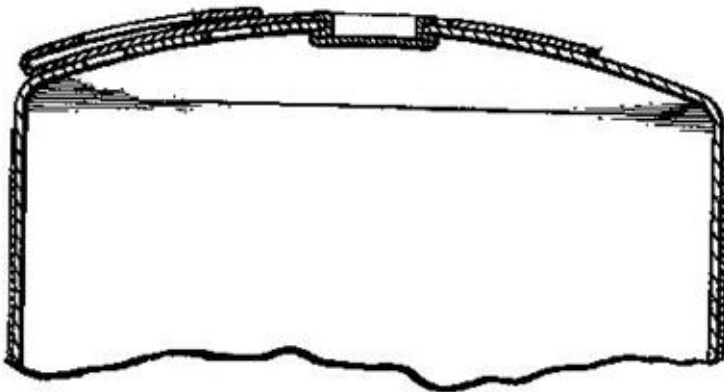

B65D 2517/0062

and provided with an additional U-shaped peripheral channel

Definition statement

This place covers:

Illustrative example of subject matter classified in this group:

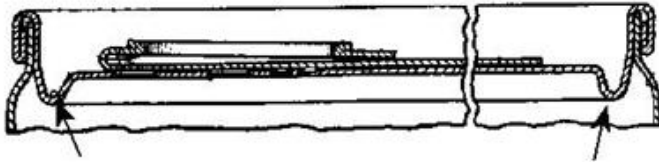

B65D 2517/0064

inverted U-shaped

Definition statement

This place covers:

Illustrative example of subject matter classified in this group:

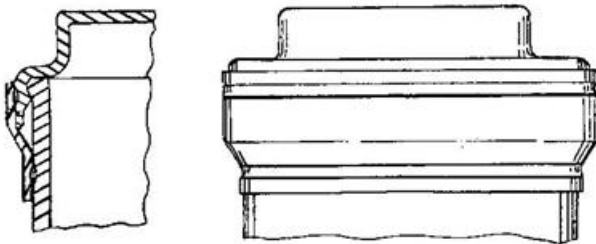

B65D 2517/0068

Ribs or projections in container end panel

Definition statement

This place covers:

Illustrative example of subject matter classified in this group:

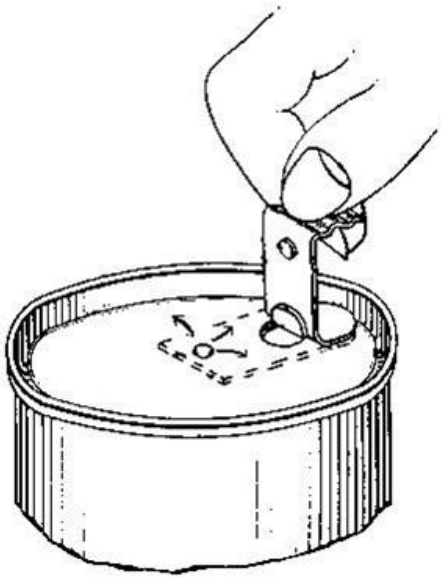

B65D 2517/0071

located externally of tear-out/push-in panel or preformed opening

References

Informative references

Attention is drawn to the following places, which may be of interest for search:

Ribs or projections in container end panel located under tab hand grip to facilitate initial lifting of the tab	B65D 2517/0073
---	--------------------------------

B65D 2517/0074

Local recess in container end panel

Definition statement

This place covers:

Illustrative example of subject matter classified in this group:

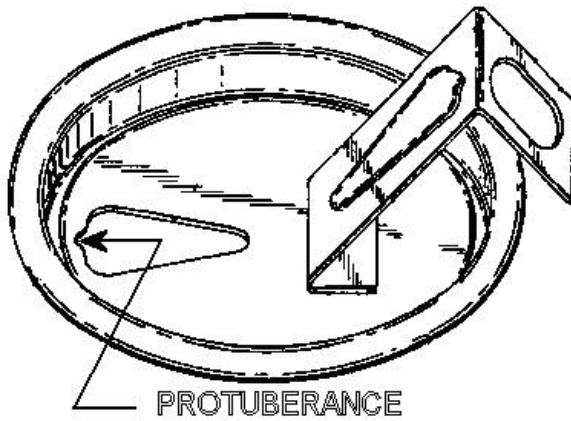

B65D 2517/0076

located beneath tab contact point

Definition statement

This place covers:

Illustrative examples of subject matter classified in this group:

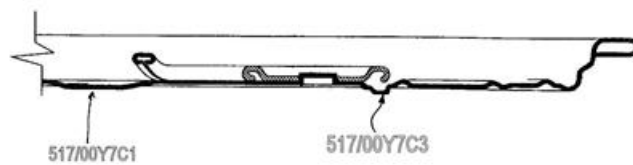

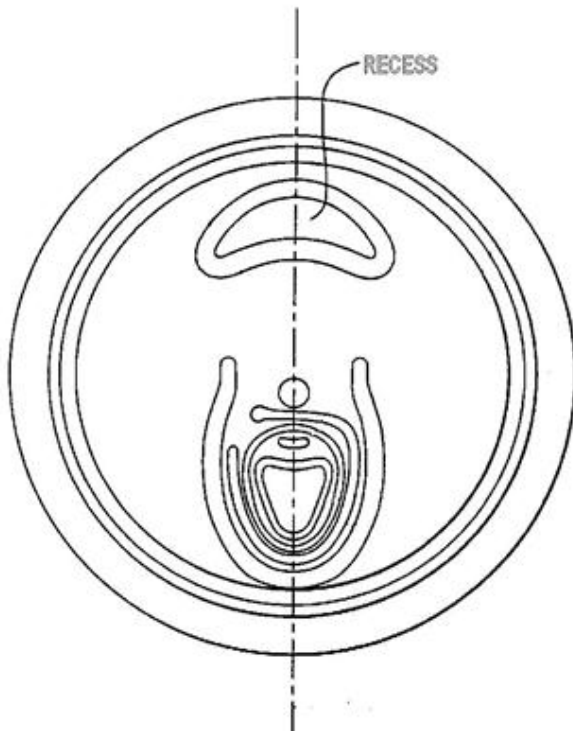

References

Informative references

Attention is drawn to the following places, which may be of interest for search:

Generally used in metal cans with opening actions	B65D 2517/0014 , B65D 2517/0016
---	--

B65D 2517/0077

located externally of tear-out/push-in panel or preformed opening

References

Informative references

Attention is drawn to the following places, which may be of interest for search:

Local recess in container end panel	B65D 2517/0074
-------------------------------------	--------------------------------

B65D 2517/0079

located beneath tab hand grip to facilitate initial lifting

Definition statement

This place covers:

Illustrative example of subject matter classified in this group:

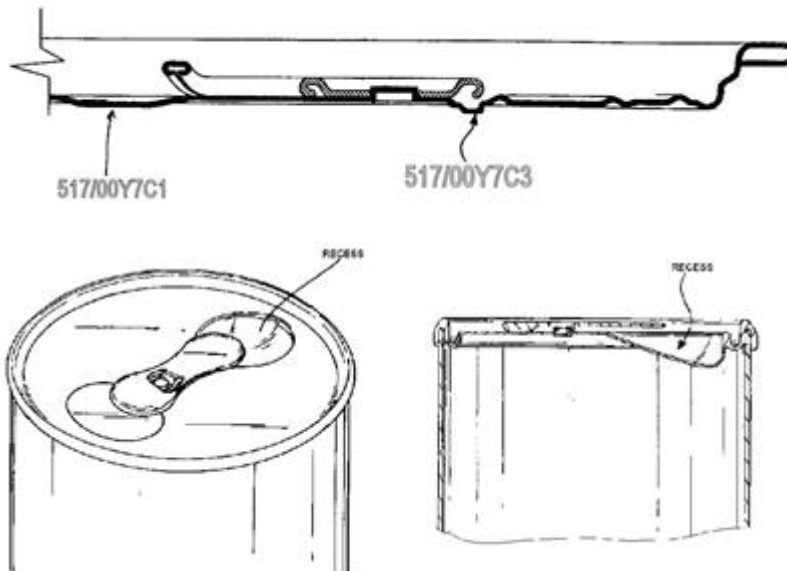

B65D 2517/0092

formed as a partial score line located close to the tab connection

Definition statement

This place covers:

Illustrative example of subject matter classified in this group:

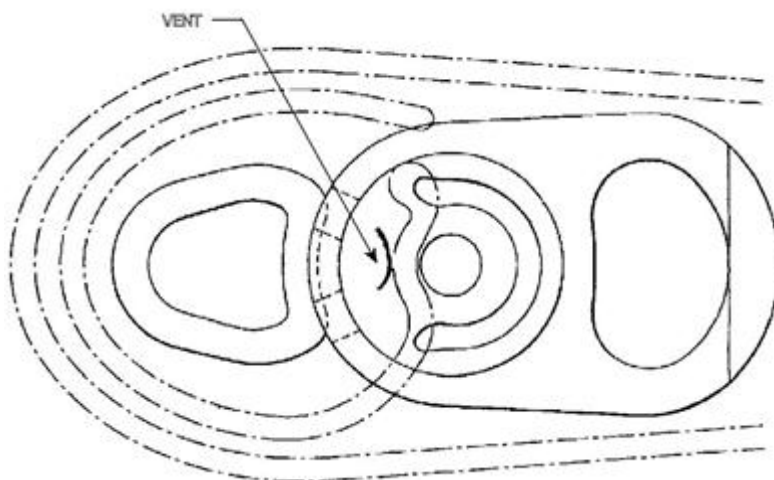

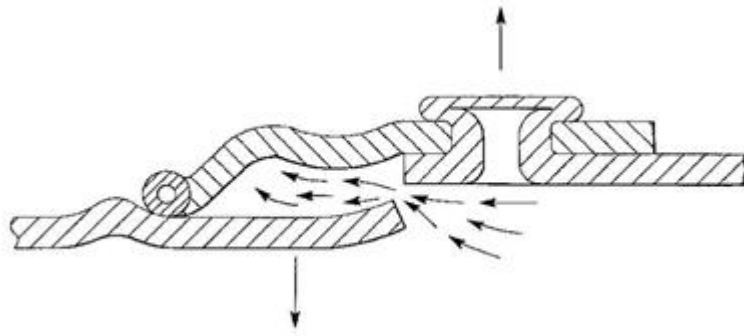

B65D 2517/0094

formed as a separate opening

Definition statement

This place covers:

Venting openings for gas in carbonated beverages

References

Informative references

Attention is drawn to the following places, which may be of interest for search:

Details of preformed openings provided with a plurality of openings	B65D 2517/5059
---	--------------------------------

B65D 2517/0098

Means for preventing dust contacting pouring opening, e.g. a cover over the tear panel

References

Informative references

Attention is drawn to the following places, which may be of interest for search:

Arrangements of closures with protective outer cap-like covers or of two or more co-operating closures the outer closure being a foil membrane	B65D 51/185
--	-----------------------------

B65D 2517/5005

with a part of the tape melted through the opening

Definition statement

This place covers:

Illustrative example of subject matter classified in this group:

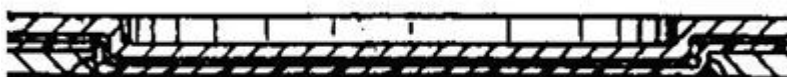

B65D 2517/5008

with a sealing coat

Definition statement

This place covers:

Illustrative example of subject matter classified in this group:

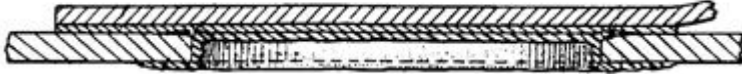

B65D 2517/501

with the tape, or one layer thereof, being folded to cover both the top and bottom of container end panel

Definition statement

This place covers:

Illustrative example of subject matter classified in this group:

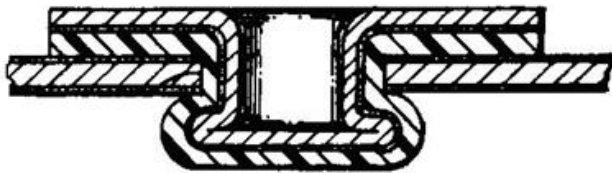

B65D 2517/5013

the tape covering almost the whole of the container end panel

Definition statement

This place covers:

Illustrative example of subject matter classified in this group:



B65D 2517/5021

Spiral shaped tear-out tape

Definition statement

This place covers:

Illustrative example of subject matter classified in this group:



B65D 2517/5048

rolled or folded back, e.g. to avoid sharp edges

Definition statement

This place covers:

Illustrative example of subject matter classified in this group:

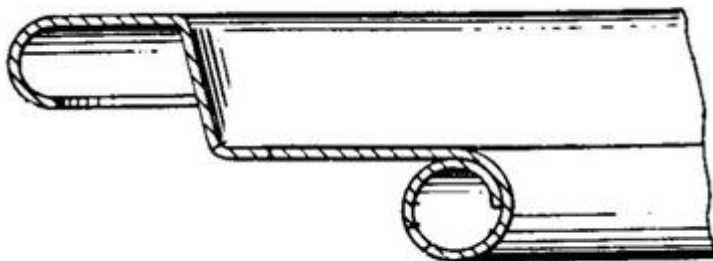

B65D 2517/5056

the edge of the preformed opening having a covering element or coating, e.g. to prevent cutting or for sealing purposes

Definition statement

This place covers:

Illustrative example of subject matter classified in this group:

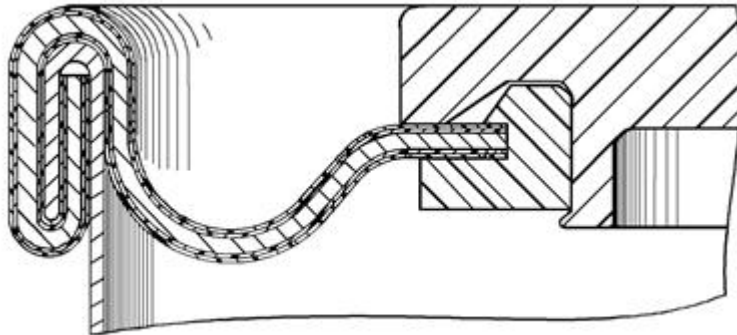

B65D 2517/5078

finger opening edge rolled or folded over

Definition statement

This place covers:

Illustrative example of subject matter classified in this group:

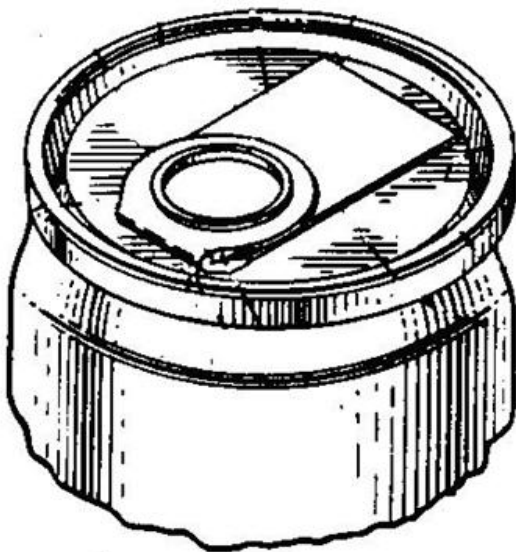

B65D 2517/5086

Tape having a U-shaped peripheral section which forms the pull-tab

Definition statement

This place covers:

Illustrative example of subject matter classified in this group:

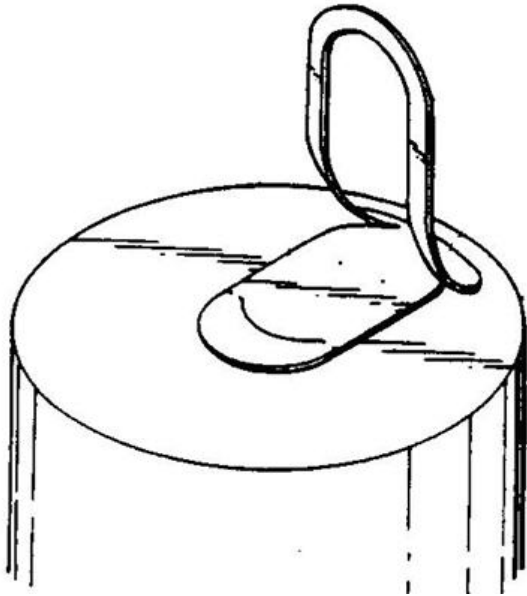

B65D 2519/00019

Paper

Definition statement

This place covers:

Illustrative example of subject matter classified in this group:



B65D 2519/00024

Metal

Definition statement

This place covers:

Illustrative example of subject matter classified in this group:

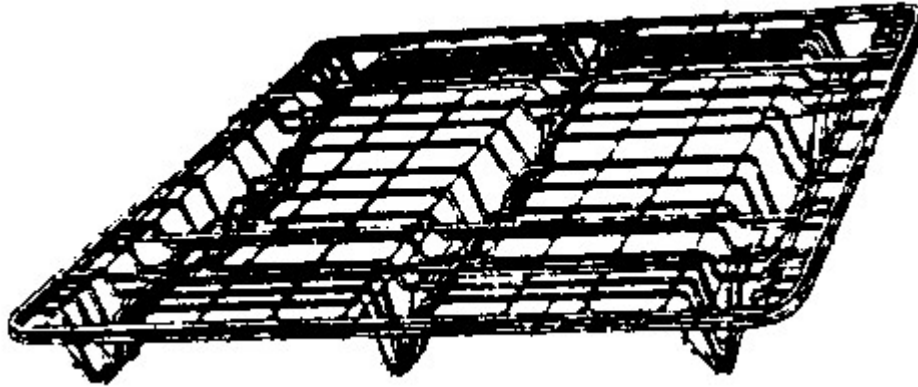

B65D 2519/00029

Wood

Definition statement

This place covers:

Illustrative example of subject matter classified in this group:

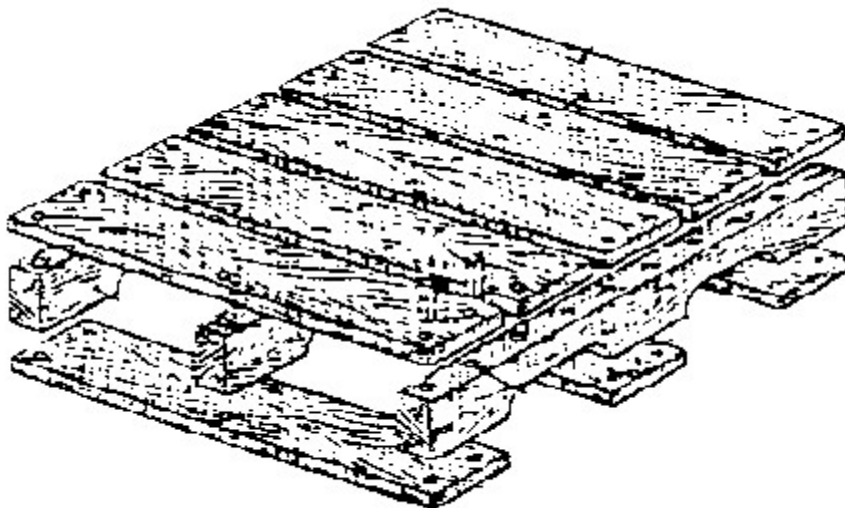

B65D 2519/00034

Plastic

Definition statement

This place covers:

Illustrative example of subject matter classified in this group:

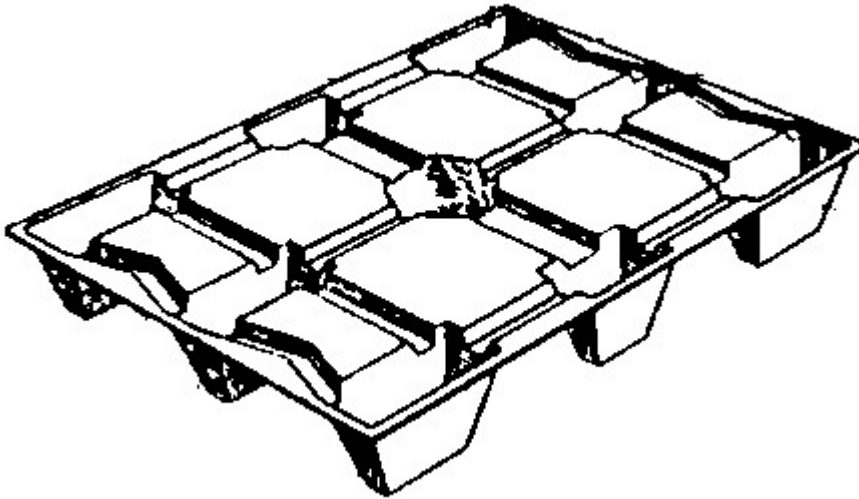

B65D 2519/00039

Agglomerates, i.e. different materials mixed together

Special rules of classification

where applicable, documents should also be classified in [B65D 2519/00019](#); [B65D 2519/00024](#); [B65D 2519/00029](#); [B65D 2519/00034](#);

B65D 2519/00044

Combination, e.g. different elements made of different materials, laminates

Special rules of classification

where applicable, documents should also be classified in [B65D 2519/00019](#); [B65D 2519/00024](#); [B65D 2519/00029](#); [B65D 2519/00034](#);

B65D 2519/00054

Paper

Definition statement

This place covers:

Illustrative example of subject matter classified in this group:

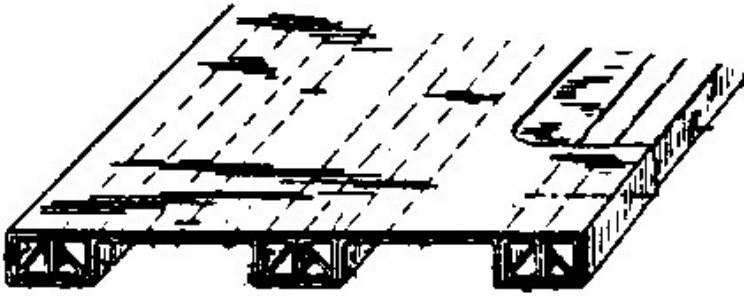

B65D 2519/00059

Metal

Definition statement

This place covers:

Illustrative example of subject matter classified in this group:

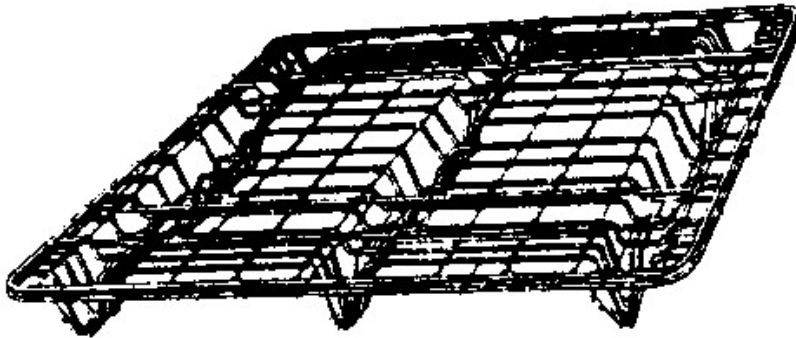

B65D 2519/00064

Wood

Definition statement

This place covers:

Illustrative example of subject matter classified in this group:

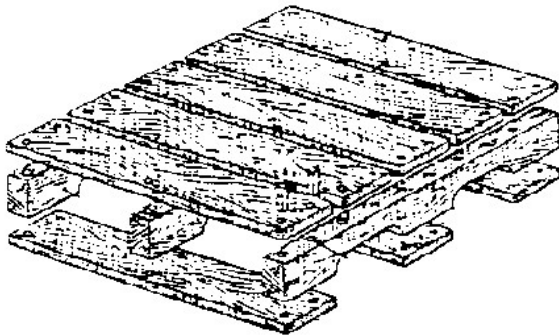

B65D 2519/00069

Plastic

Definition statement

This place covers:

Illustrative example of subject matter classified in this group:

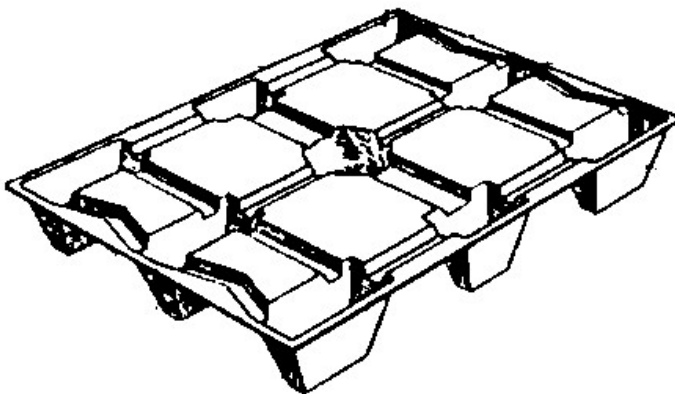

B65D 2519/00074

Agglomerates, i.e. different materials mixed together

Special rules of classification

Where applicable, documents should also be classified in [B65D 2519/00054](#); [B65D 2519/00059](#); [B65D 2519/00064](#); [B65D 2519/00069](#);

B65D 2519/00079

Combination, e.g. different elements made of different materials, laminates

Special rules of classification

Where applicable, documents should also be classified in [B65D 2519/00054](#); [B65D 2519/00059](#); [B65D 2519/00064](#); [B65D 2519/00069](#);

B65D 2519/00084

for the non-integral separating spacer

Special rules of classification

If the separating spacer is integral with the load supporting surface or base surface, then it is considered to be part of the load supporting surface or base surface. Such documents should not be classified here.

B65D 2519/00099

Wood

Definition statement

This place covers:

Illustrative example of subject matter classified in this group:

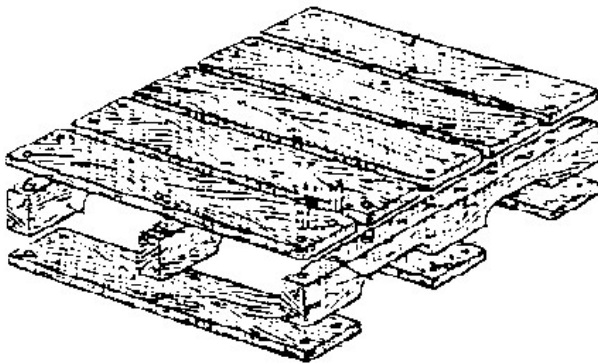

B65D 2519/00109

Agglomerates, i.e. different materials mixed together

Special rules of classification

Where applicable, documents should also be classified in [B65D 2519/00089](#); [B65D 2519/00094](#); [B65D 2519/00099](#); [B65D 2519/00104](#);

B65D 2519/00114

Combination, e.g. different elements made of different materials, laminates

Special rules of classification

Where applicable, documents should also be classified in [B65D 2519/00089](#); [B65D 2519/00094](#); [B65D 2519/00099](#); [B65D 2519/00104](#);

B65D 2519/00119

for the construction of the reinforcements (not used for the integral reinforcements)

Special rules of classification

Reinforcements which are integral with the load supporting surface and/or base surface and/or spacers should not be classified here.

B65D 2519/00124

Paper

Definition statement

This place covers:

Illustrative example of subject matter classified in this group:

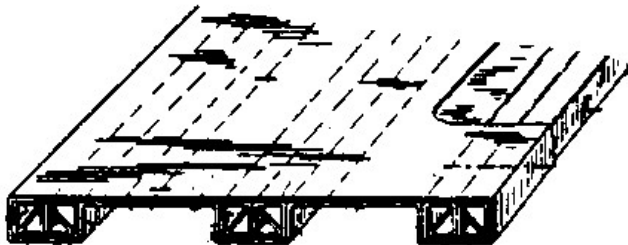

B65D 2519/00144

Agglomerates, i.e. different materials mixed together

Special rules of classification

where applicable, documents should also be classified in [B65D 2519/00124](#), [B65D 2519/00129](#), [B65D 2519/00134](#), [B65D 2519/00139](#).

B65D 2519/00149

Combination, e.g. different elements made of different materials, laminates

Special rules of classification

where applicable, documents should also be classified in [B65D 2519/00124](#), [B65D 2519/00129](#), [B65D 2519/00134](#), [B65D 2519/00139](#).

B65D 2519/00179

Agglomerates, i.e. different materials mixed together

Special rules of classification

where applicable, documents should also be classified in [B65D 2519/00159](#), [B65D 2519/00164](#), [B65D 2519/00169](#), [B65D 2519/00174](#).

B65D 2519/00184

Combination, e.g. different elements made of different materials, laminates

Special rules of classification

where applicable, documents should also be classified in [B65D 2519/00159](#), [B65D 2519/00164](#), [B65D 2519/00169](#), [B65D 2519/00174](#).

B65D 2519/00213

Agglomerates, i.e. different materials mixed together

Special rules of classification

where applicable, documents should also be classified in [B65D 2519/00194](#), [B65D 2519/00199](#), [B65D 2519/00203](#), [B65D 2519/00208](#).

B65D 2519/00218

Combination, e.g. different elements made of different materials, laminates

Special rules of classification

where applicable, documents should also be classified in [B65D 2519/00194](#), [B65D 2519/00199](#), [B65D 2519/00203](#), [B65D 2519/00208](#).

B65D 2519/00248

Agglomerates, i.e. different materials mixed together

Special rules of classification

where applicable, documents should also be classified in [B65D 2519/00228](#), [B65D 2519/00233](#), [B65D 2519/00238](#), [B65D 2519/00243](#).

B65D 2519/00253

Combination, e.g. different elements made of different materials, laminates

Special rules of classification

where applicable, documents should also be classified in [B65D 2519/00228](#), [B65D 2519/00233](#), [B65D 2519/00238](#), [B65D 2519/00243](#).

B65D 2519/00268

made of one piece

Definition statement

This place covers:

Illustrative example of subject matter classified in this group:

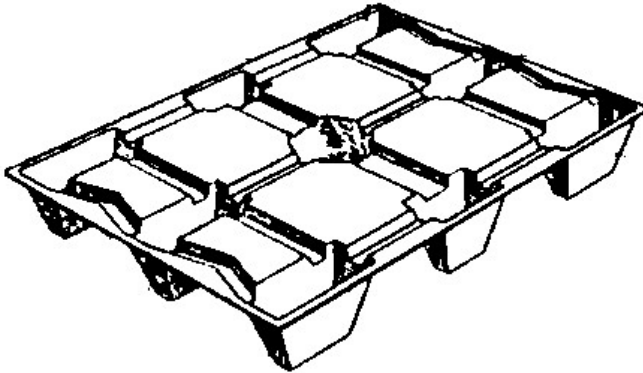

B65D 2519/00273

made of more than one piece

Definition statement

This place covers:

Illustrative example of subject matter classified in this group:

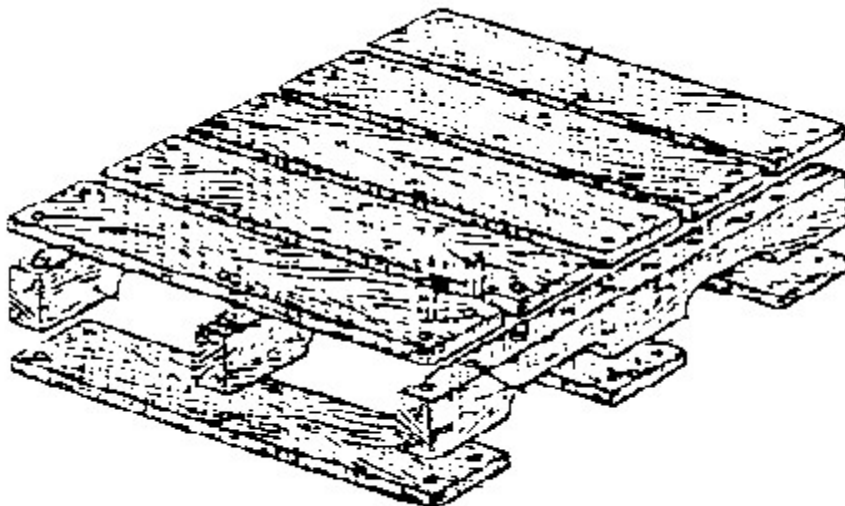

B65D 2519/00288

made of one piece

Definition statement

This place covers:

Illustrative example of subject matter classified in this group:

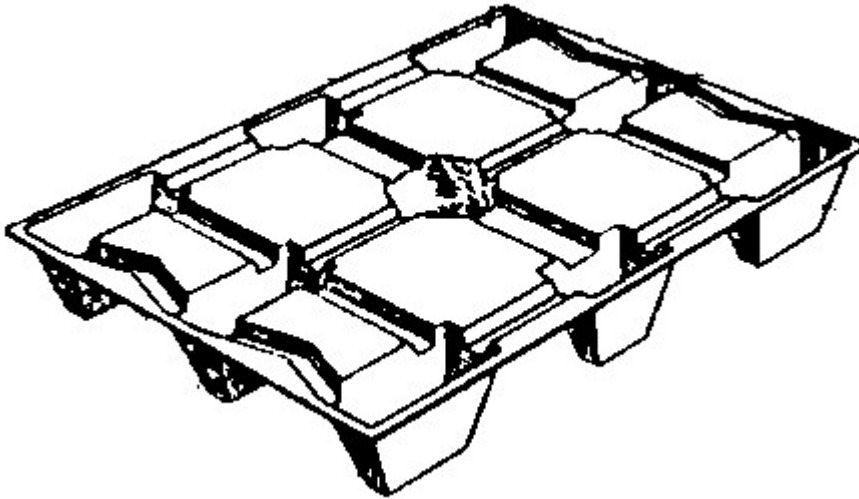

B65D 2519/00293

made of more than one piece

Definition statement

This place covers:

Illustrative example of subject matter classified in this group:

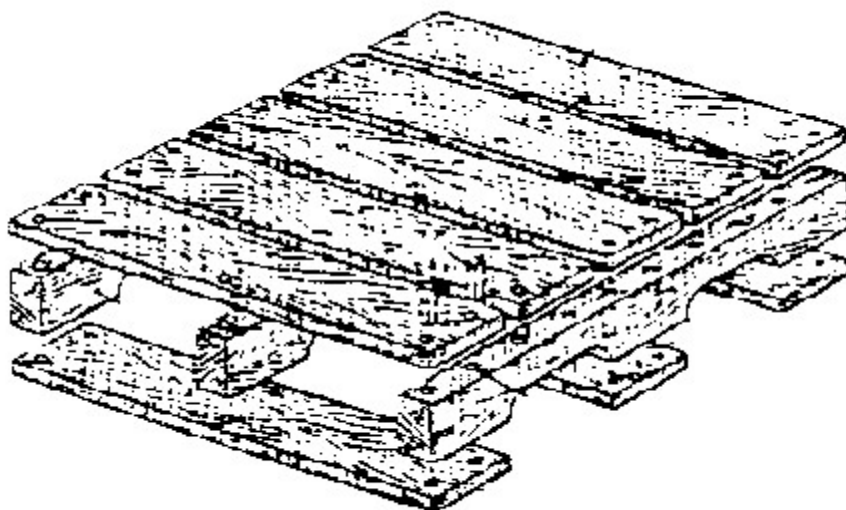

B65D 2519/00298**skeleton type****Definition statement**

This place covers:

Illustrative example of subject matter classified in this group:

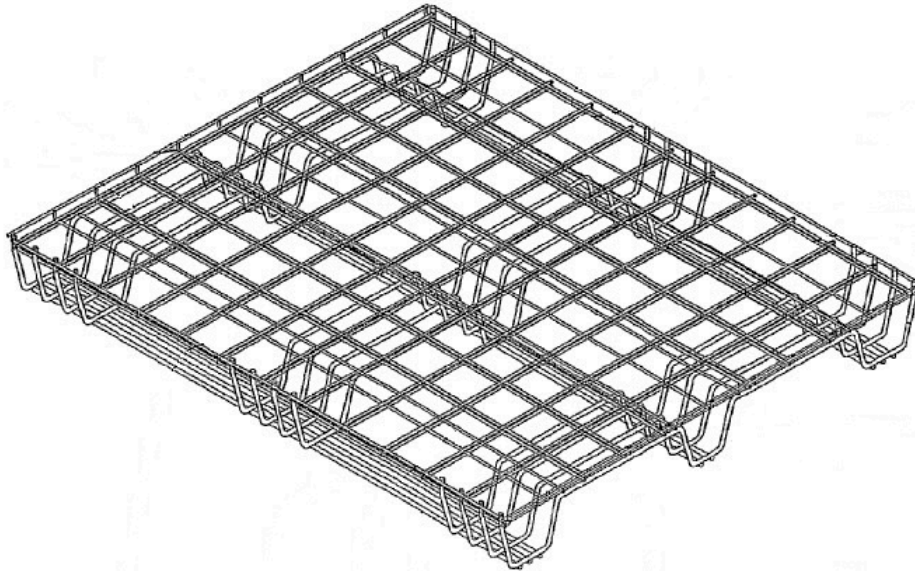

WO0240361, Figure 1a, load supporting surface of the skeleton type

References**Informative references**

Attention is drawn to the following places, which may be of interest for search:

Grid type, e.g. perforated plate	B65D 2519/00308
----------------------------------	---------------------------------

Glossary of terms

In this place, the following terms or expressions are used with the meaning indicated:

Grid	Planar or non-planar member with opposing surfaces provided with a plurality of holes, openings, or apertures traversing there through from one surface to the opposing surface
Skeleton	Structure consisting of a plurality of spaced bars, rods, wire or pipes forming a lattice structure

B65D 2519/00308

grid type, e.g. perforated plate

Definition statement

This place covers:

Illustrative example of subject matter classified in this group:

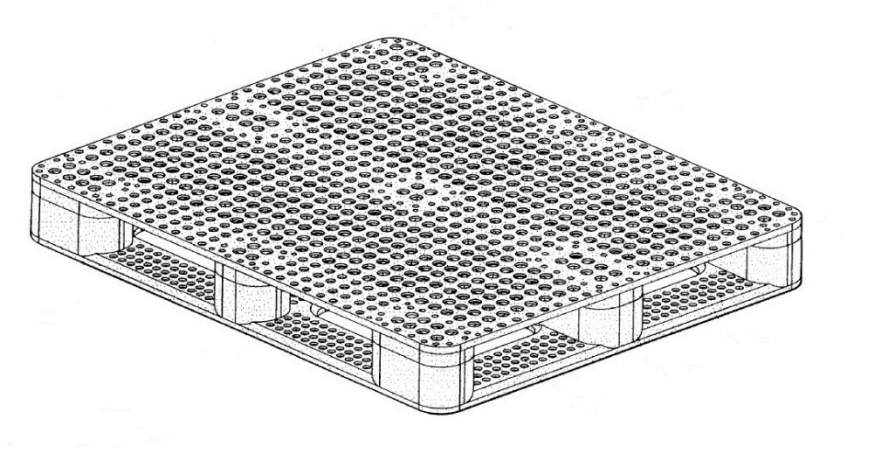

WO0001588, Figure 1, planar load supporting surface of the grid type

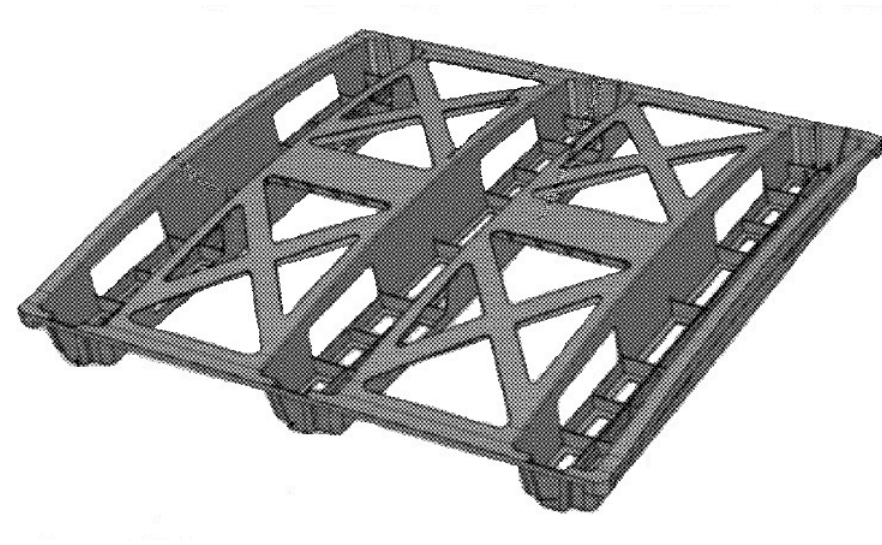

US20120037050, Figure 4, non-planar load supporting surface of the grid type

References**Informative references**

Attention is drawn to the following places, which may be of interest for search:

Skeleton type	B65D 2519/00298
---------------	---------------------------------

Glossary of terms

In this place, the following terms or expressions are used with the meaning indicated:

Grid	Planar or non-planar member with opposing surfaces provided with a plurality of holes, openings, or apertures traversing there through from one surface to the opposing surface
Skeleton	Structure consisting of a plurality of spaced bars, rods, wire or pipes forming a lattice structure

B65D 2519/00318

made of one piece

Definition statement

This place covers:

Illustrative example of subject matter classified in this group:

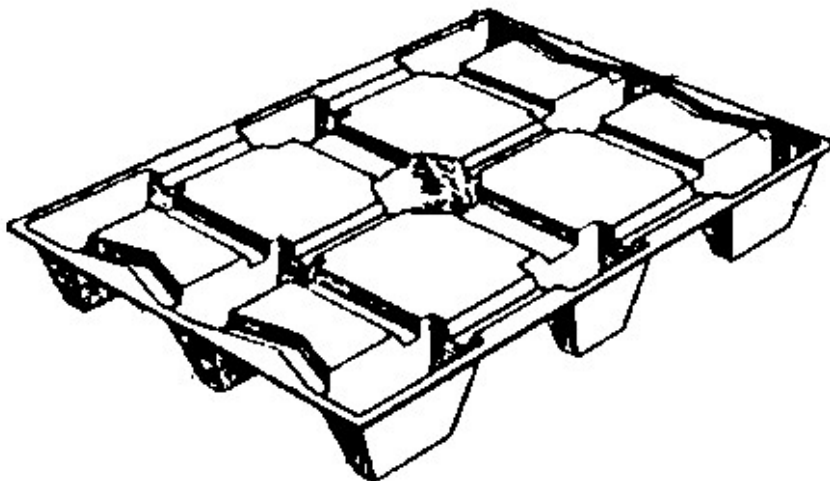

B65D 2519/00323

made of more than one piece

Definition statement

This place covers:

Illustrative example of subject matter classified in this group:

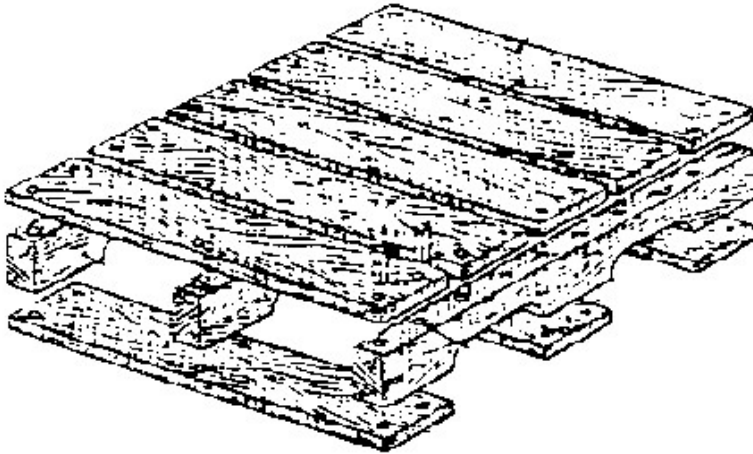

B65D 2519/00333

contact surface having a stringer-like shape

Definition statement

This place covers:

Illustrative example of subject matter classified in this group:

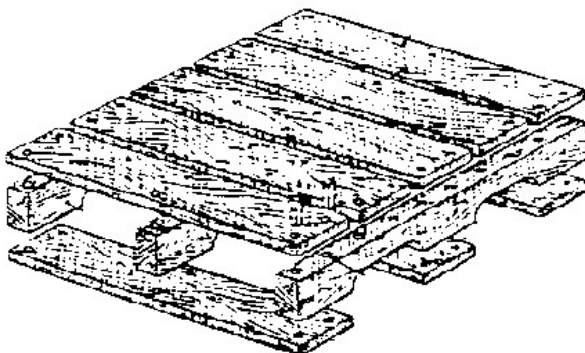

B65D 2519/00338

contact surface having a discrete foot-like shape

Definition statement

This place covers:

Illustrative example of subject matter classified in this group:

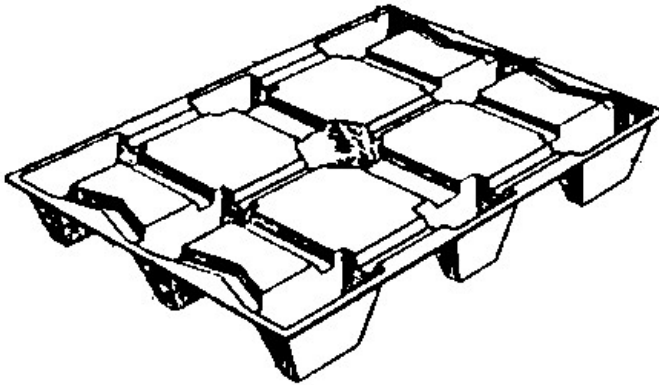

B65D 2519/00353

skeleton type

Definition statement

This place covers:

Illustrative example of subject matter classified in this group:

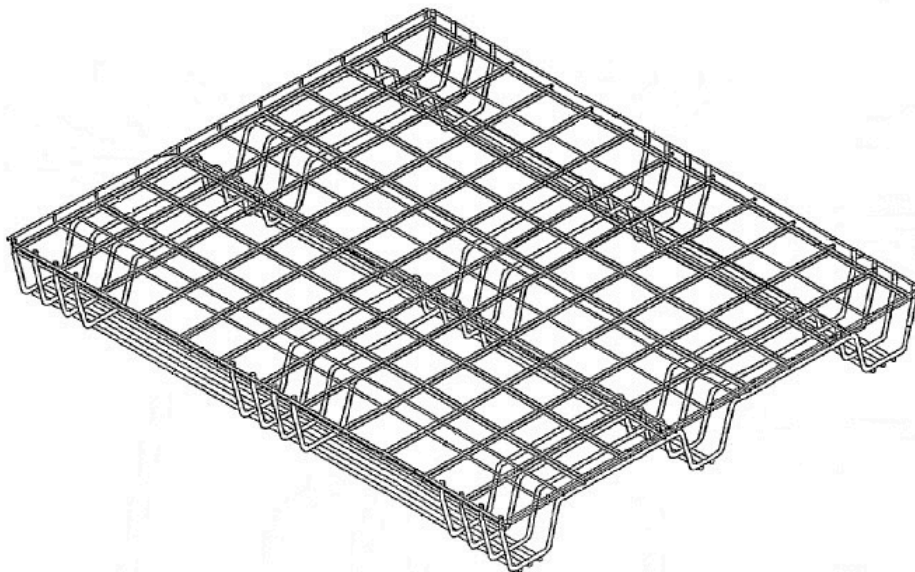

WO0240361, Figure 1a, base surface of the skeleton type

References

Informative references

Attention is drawn to the following places, which may be of interest for search:

Grid type, e.g. perforated plate	B65D 2519/00363
----------------------------------	---------------------------------

Glossary of terms

In this place, the following terms or expressions are used with the meaning indicated:

Grid	Planar or non-planar member with opposing surfaces provided with a plurality of holes, openings, or apertures traversing there through from one surface to the opposing surface
Skeleton	Structure consisting of a plurality of spaced bars, rods, wire or pipes forming a lattice structure

B65D 2519/00363

grid type, e.g. perforated plate

Definition statement

This place covers:

Illustrative example of subject matter classified in this group:

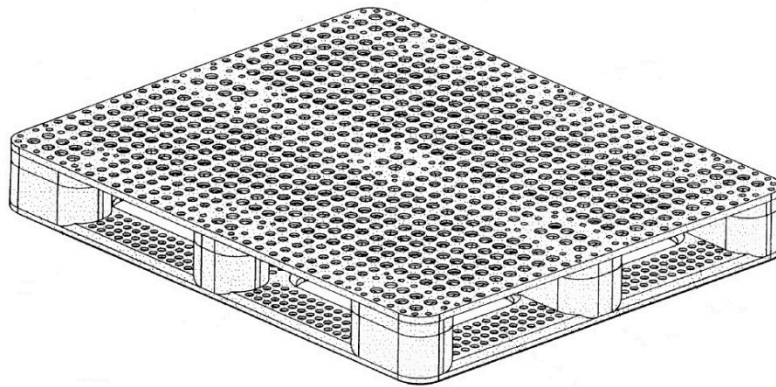

WO0001588, Figure 1, planar base surface of the grid type

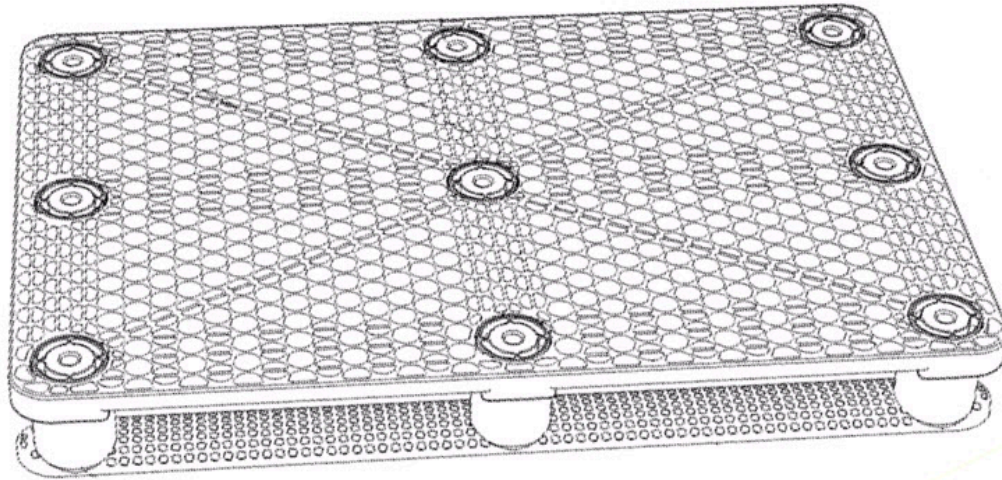

WO2013022400, Figure 1, non-planar base surface of the grid type

References

Informative references

Attention is drawn to the following places, which may be of interest for search:

Skeleton type	B65D 2519/00353
---------------	---------------------------------

Glossary of terms

In this place, the following terms or expressions are used with the meaning indicated:

Grid	Planar or non-planar member with opposing surfaces provided with a plurality of holes, openings, or apertures traversing there through from one surface to the opposing surface
Skeleton	Structure consisting of a plurality of spaced bars, rods, wire or pipes forming a lattice structure

B65D 2519/00368

of the non-integral separating spacer

References

Limiting references

This place does not cover:

If the separating spacer is integral with the load supporting surface or base surface, then it is considered to be part of the load supporting surface or base surface. Such documents should not be classified here.

B65D 2519/00373

whereby at least one spacer is made of one piece

Definition statement

This place covers:

Illustrative example of subject matter classified in this group:

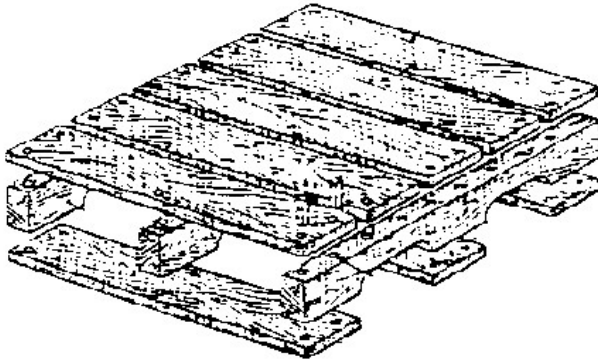

B65D 2519/00383

skeleton type

Definition statement

This place covers:

Illustrative example of subject matter classified in this group:

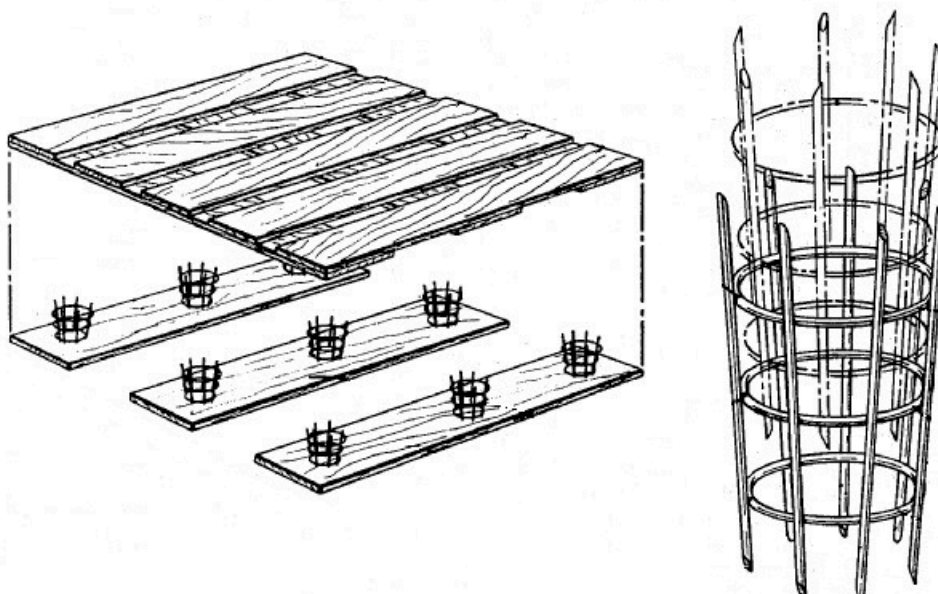

US3835791, Figures 4 and 5, non-integral separating spacers of the skeleton type

References

Informative references

Attention is drawn to the following places, which may be of interest for search:

Grid type, e.g. perforated plate	B65D 2519/00393
----------------------------------	---------------------------------

Glossary of terms

In this place, the following terms or expressions are used with the meaning indicated:

Grid	Planar or non-planar member with opposing surfaces provided with a plurality of holes, openings, or apertures traversing there through from one surface to the opposing surface
Skeleton	Structure consisting of a plurality of spaced bars, rods, wire or pipes forming a lattice structure

B65D 2519/00393

grid type, e.g. perforated plate

References

Informative references

Attention is drawn to the following places, which may be of interest for search:

Skeleton type	B65D 2519/00383
---------------	---------------------------------

Glossary of terms

In this place, the following terms or expressions are used with the meaning indicated:

Grid	Planar or non-planar member with opposing surfaces provided with a plurality of holes, openings, or apertures traversing there through from one surface to the opposing surface
Skeleton	Structure consisting of a plurality of spaced bars, rods, wire or pipes forming a lattice structure

B65D 2519/00512

skeleton type

References

Informative references

Attention is drawn to the following places, which may be of interest for search:

Grid type, e.g. perforated plate	B65D 2519/00522
----------------------------------	---------------------------------

Glossary of terms

In this place, the following terms or expressions are used with the meaning indicated:

Grid	Planar or non-planar member with opposing surfaces provided with a plurality of holes, openings, or apertures traversing there through from one surface to the opposing surface
Skeleton	Structure consisting of a plurality of spaced bars, rods, wire or pipes forming a lattice structure

B65D 2519/00522

grid type, e.g. perforated plate

References

Informative references

Attention is drawn to the following places, which may be of interest for search:

Skeleton type	B65D 2519/00512
---------------	---------------------------------

Glossary of terms

In this place, the following terms or expressions are used with the meaning indicated:

Grid	Planar or non-planar member with opposing surfaces provided with a plurality of holes, openings, or apertures traversing there through from one surface to the opposing surface
Skeleton	Structure consisting of a plurality of spaced bars, rods, wire or pipes forming a lattice structure

B65D 2519/00532

Frame structures

References

Informative references

Attention is drawn to the following places, which may be of interest for search:

Frames, corner posts or pallet converters	B65D 19/385
---	-----------------------------

B65D 2519/00781

for moving on a surface, e.g. wheels, pads ([B65D 2519/00825](#) takes precedence)

References

Informative references

Attention is drawn to the following places, which may be of interest for search:

Arrangements or applications of rollers or wheels	B65D 19/42
Finishing of the external surfaces	B65D 2519/00825

B65D 2519/00796**Guiding means for fork-lift****Special rules of classification**

normal openings between the load supporting surface and base surface are not considered as guiding means and therefore are not classified here;

B65D 2519/0081**Elements or devices for locating articles****References****Informative references**

Attention is drawn to the following places, which may be of interest for search:

Elements or devices for locating articles on platforms	B65D 19/44
--	----------------------------

B65D 2519/00815**on the pallet****Definition statement**

This place covers:

Illustrative example of subject matter classified in this group:

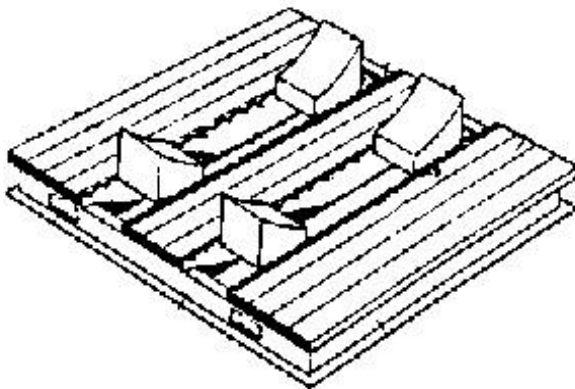
**References****Informative references**

Attention is drawn to the following places, which may be of interest for search:

Elements or devices for locating articles on platforms	B65D 19/44
--	----------------------------

B65D 2519/0082**in the side wall****References*****Informative references***

Attention is drawn to the following places, which may be of interest for search:

Elements or devices for locating articles on platforms	B65D 19/44
--	----------------------------

B65D 2539/003**provided with sealing flanges or ribs****Definition statement**

This place covers:

Illustrative example of subject matter classified in this group:

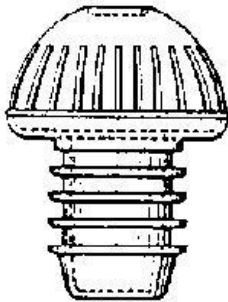
**B65D 2539/005****provided with slits or gaps for increasing the elasticity****Definition statement**

This place covers:

Illustrative example of subject matter classified in this group:

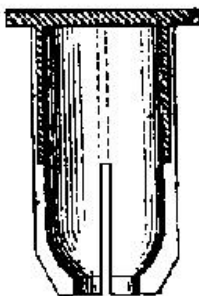

B65D 2539/006

provided with separate sealing rings

Definition statement

This place covers:

Illustrative example of subject matter classified in this group:



B65D 2539/008

with coatings or coverings

Definition statement

This place covers:

Illustrative example of subject matter classified in this group:

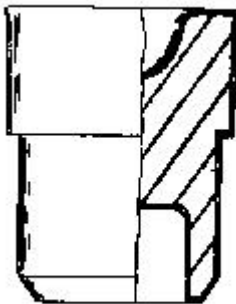

B65D 2543/00009

Details of lids or covers for rigid or semi-rigid containers

Definition statement

This place covers:

Also used for [B65D 43/16](#), but don't forget also the [B65D 2251/10](#).

References

Limiting references

This place does not cover:

More general details relating to container closures	B65D 2251/00
---	------------------------------

B65D 2543/00027

Stackable lids or covers

Definition statement

This place covers:

Illustrative example of subject matter classified in this group:

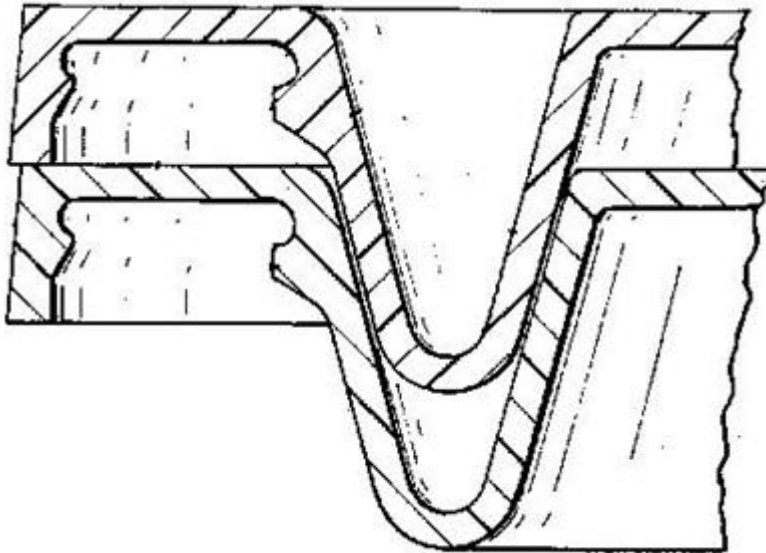

B65D 2543/00037

Disc closures

Definition statement

This place covers:

Illustrative example of subject matter classified in this group:

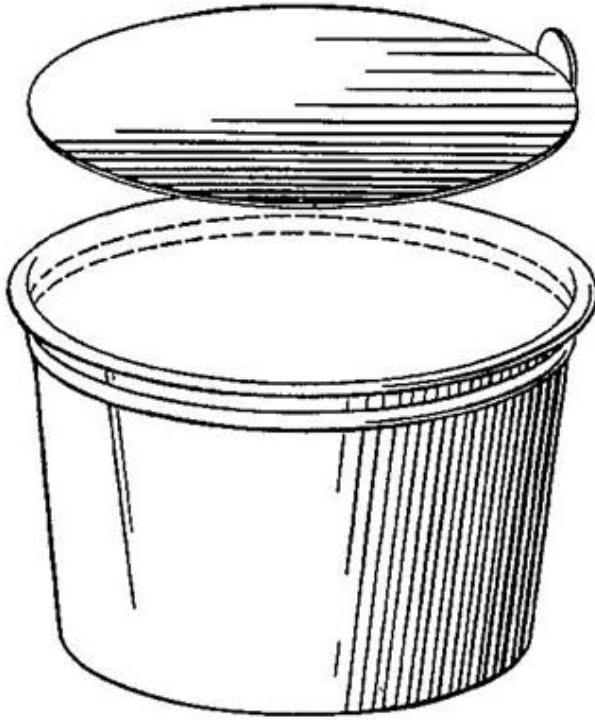

References

Informative references

Attention is drawn to the following places, which may be of interest for search:

Disc closures	B65D 39/02
Rigid discs or spherical members adapted to be held in sealing engagement with mouth of container	B65D 51/14

B65D 2543/00046

Drinking-through lids

Definition statement

This place covers:

Illustrative example of subject matter classified in this group:

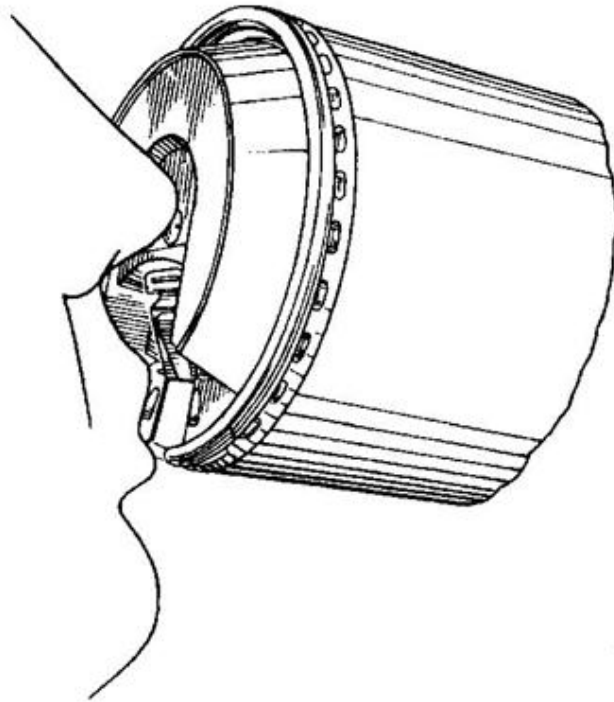

References

Informative references

Attention is drawn to the following places, which may be of interest for search:

Means for facilitating drinking from drinking glasses or cups comprising lids or covers	A47G 19/2272
---	------------------------------

B65D 2543/00055**Lids serving as, or incorporating, drinking or measuring vessels****Definition statement**

This place covers:

Illustrative example of subject matter classified in this group:

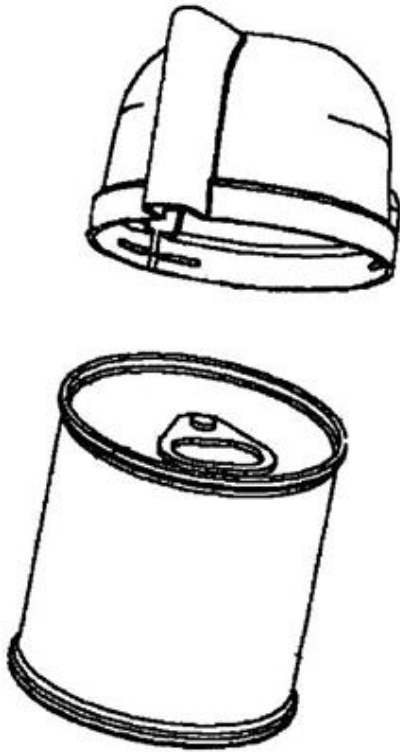
**References****Limiting references**

This place does not cover:

Measuring cups	G01F 19/00
----------------	----------------------------

Informative references

Attention is drawn to the following places, which may be of interest for search:

Caps or cap-like covers serving as, or incorporating, drinking or measuring vessels	B65D 41/26
Caps or cap-like covers serving as, or incorporating, drinking or measuring vessels	B65D 41/56

B65D 2543/00074

curved (combined with straight sides [B65D 2543/0012](#))

Definition statement

This place covers:

Illustrative example of subject matter classified in this group:

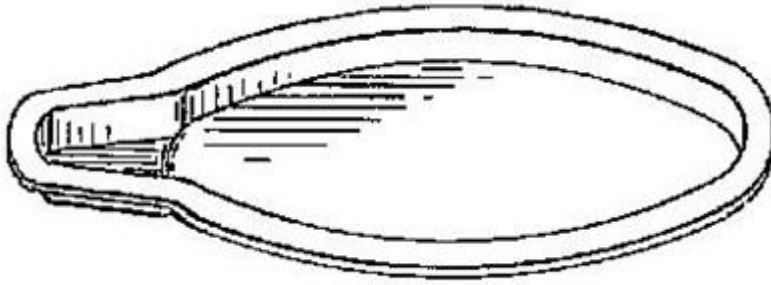

B65D 2543/00101

square-like or rectangular-like

Definition statement

This place covers:

Illustrative example of subject matter classified in this group:

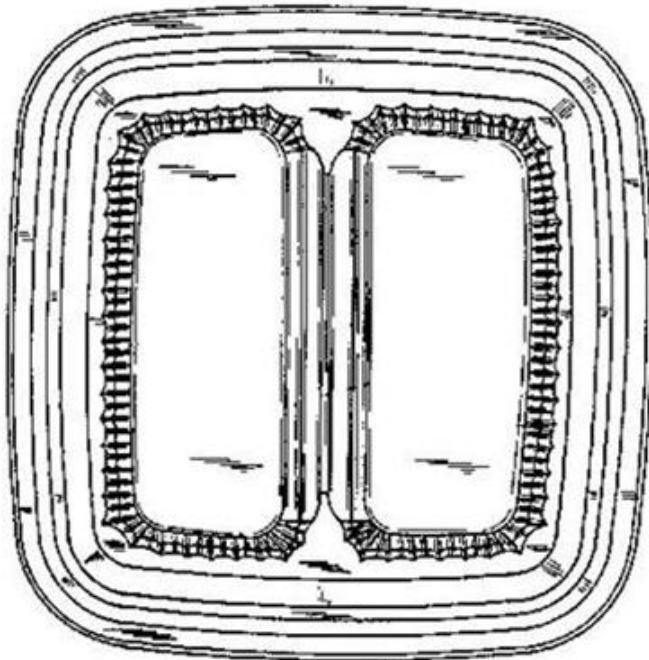

B65D 2543/00111

triangular-like, i.e. three curved sides

Definition statement

This place covers:

Illustrative example of subject matter classified in this group:

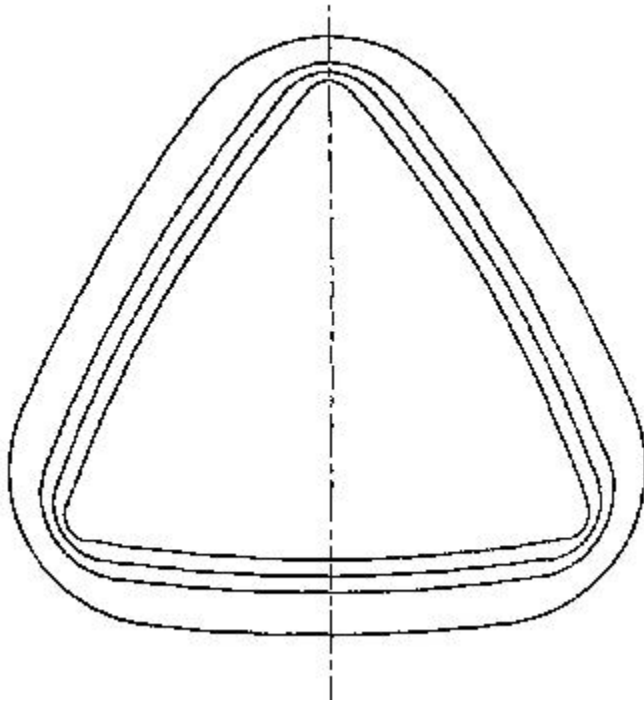

B65D 2543/0012

having straight sides, e.g. with curved corners

Definition statement

This place covers:

Illustrative example of subject matter classified in this group:

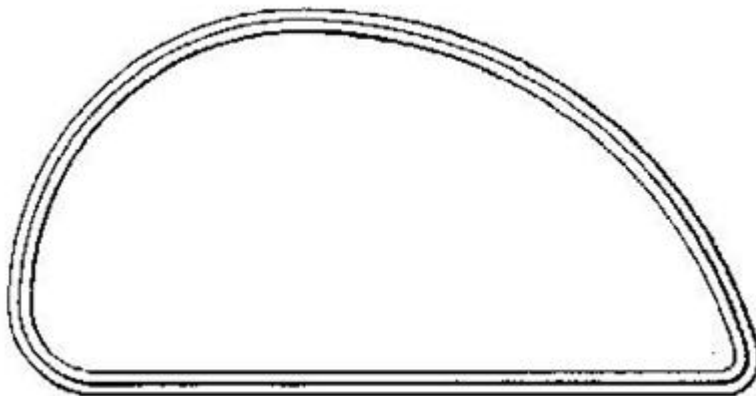

B65D 2543/00138

with one curved side

Definition statement

This place covers:

Illustrative example of subject matter classified in this group:

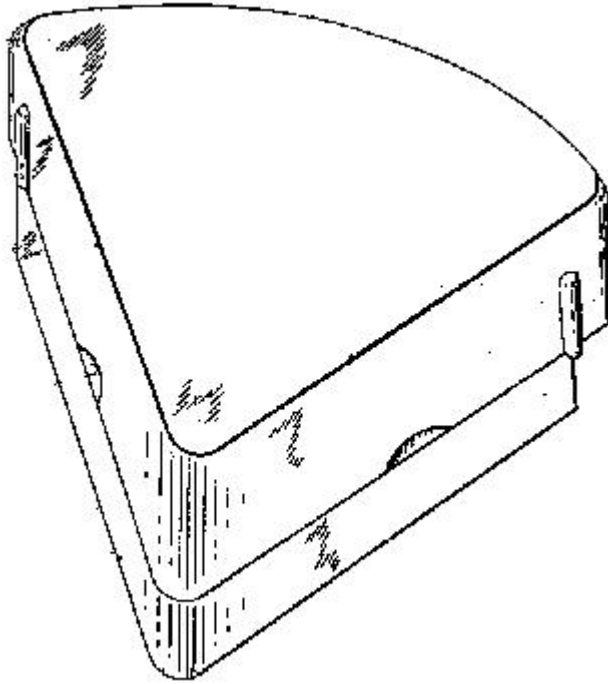

B65D 2543/00148

with two curved sides

Definition statement

This place covers:

Illustrative example of subject matter classified in this group:

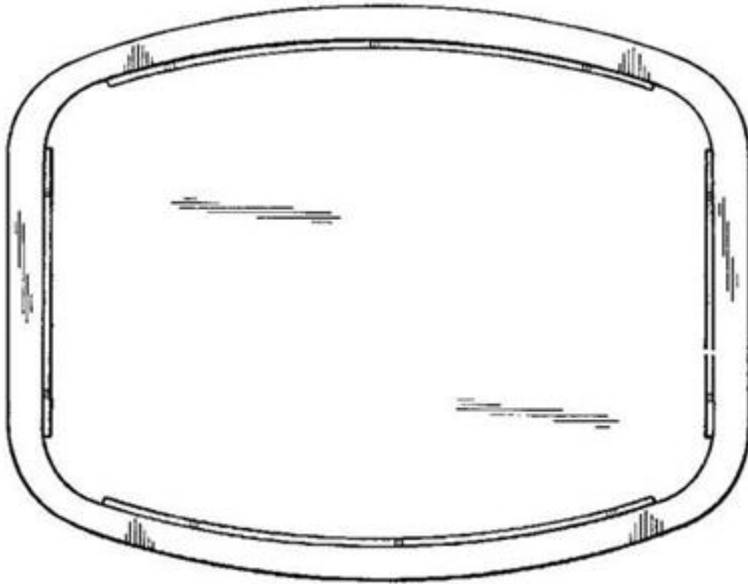

B65D 2543/00166

and at least one curved side

Definition statement

This place covers:

Illustrative example of subject matter classified in this group:

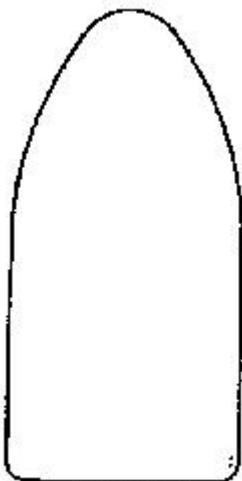

B65D 2543/00175

four straight sides, e.g. trapezium or diamond

Definition statement

This place covers:

Illustrative example of subject matter classified in this group:

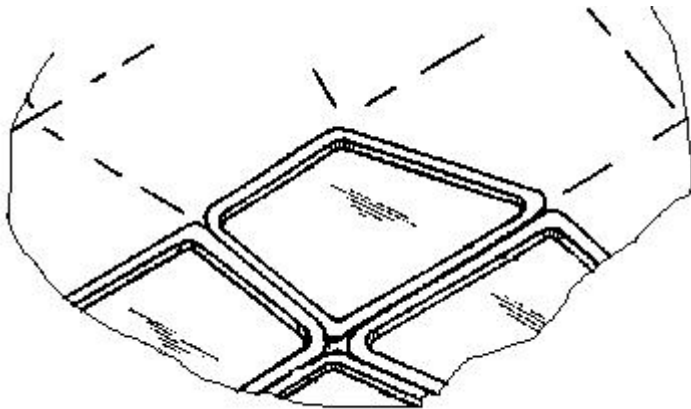

B65D 2543/00185

and at least one curved side

Definition statement

This place covers:

Illustrative example of subject matter classified in this group:

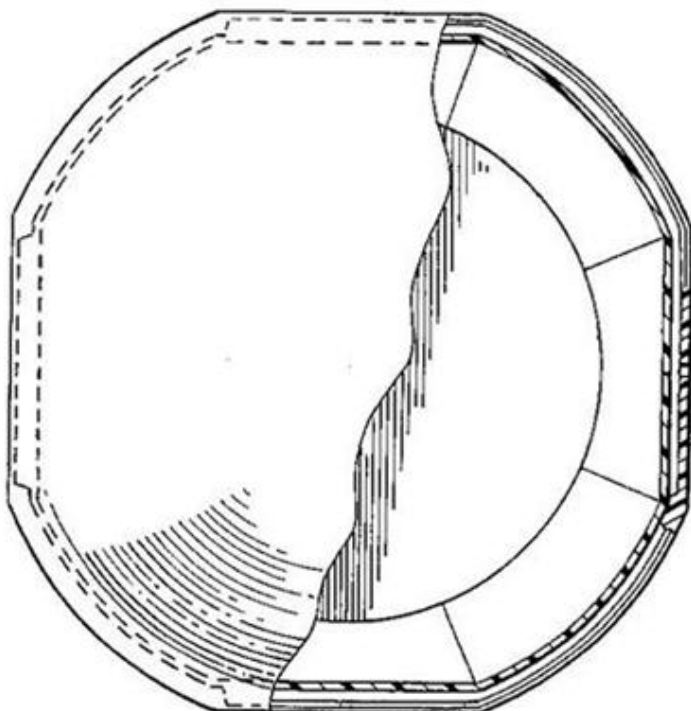

B65D 2543/0022**Hollow and made of one piece****Definition statement***This place covers:*

Illustrative example of subject matter classified in this group:

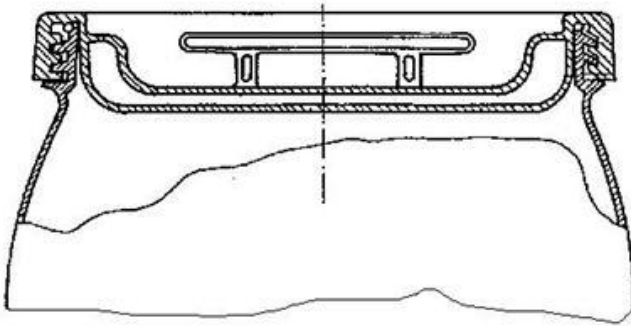
**B65D 2543/00231****made of several pieces****References****Limiting references***This place does not cover:*

Several materials	B65D 2543/00314
-------------------	---------------------------------

B65D 2543/0024

two pieces, one forming at least the whole skirt, the other forming at least the whole upper part

Definition statement

This place covers:

Illustrative example of subject matter classified in this group:

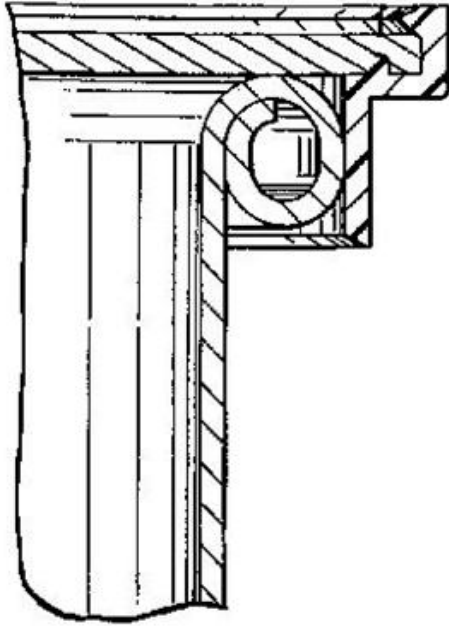

B65D 2543/0025

Multi-position closures

Definition statement

This place covers:

Illustrative example of subject matter classified in this group:

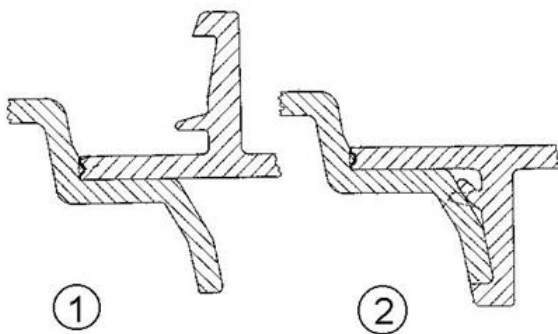

References

Limiting references

This place does not cover:

Specifically formed for supporting the container	B65D 51/249
--	-----------------------------

Informative references

Attention is drawn to the following places, which may be of interest for search:

Closures specially adapted for closing container mouths of differing size or configuration	B65D 2251/08
--	------------------------------

B65D 2543/00324

Lids integrally moulded with the container, or with a connecting piece, and separated therefrom by rupturing the connection before the first use

Definition statement

This place covers:

Illustrative example of subject matter classified in this group:

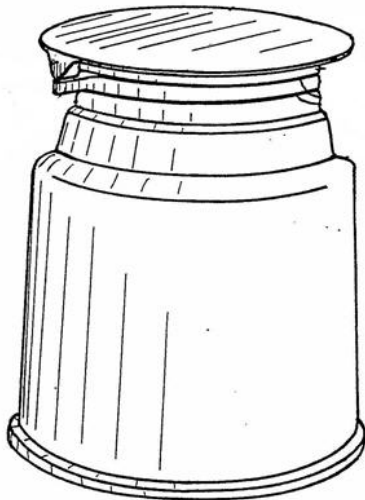

References

Informative references

Attention is drawn to the following places, which may be of interest for search:

Integral frangible closures	B65D 1/0238
Integral, or permanently secured, end or side closures	B65D 17/06

B65D 2543/00333

Not reusable, e.g. destroyed on opening

Definition statement

This place covers:

Illustrative example of subject matter classified in this group:

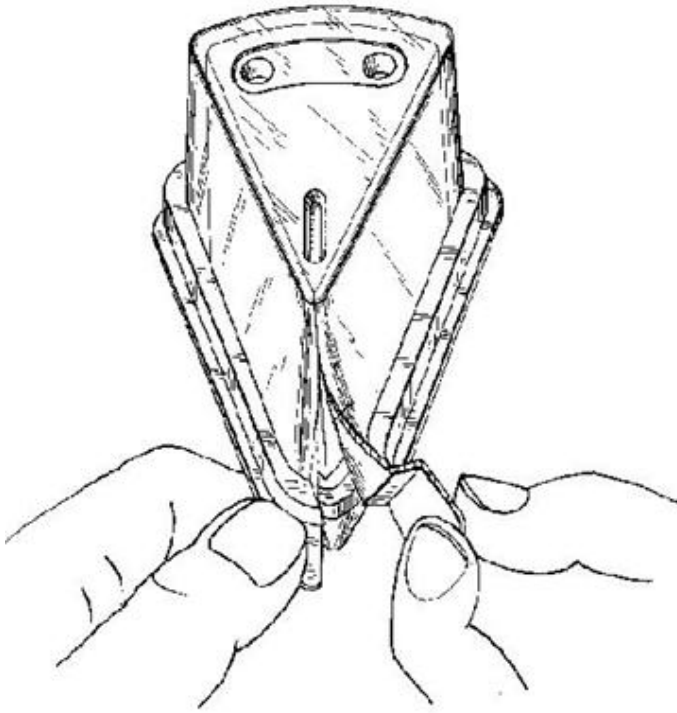

B65D 2543/00351

Dome-like

Definition statement

This place covers:

Illustrative example of subject matter classified in this group:

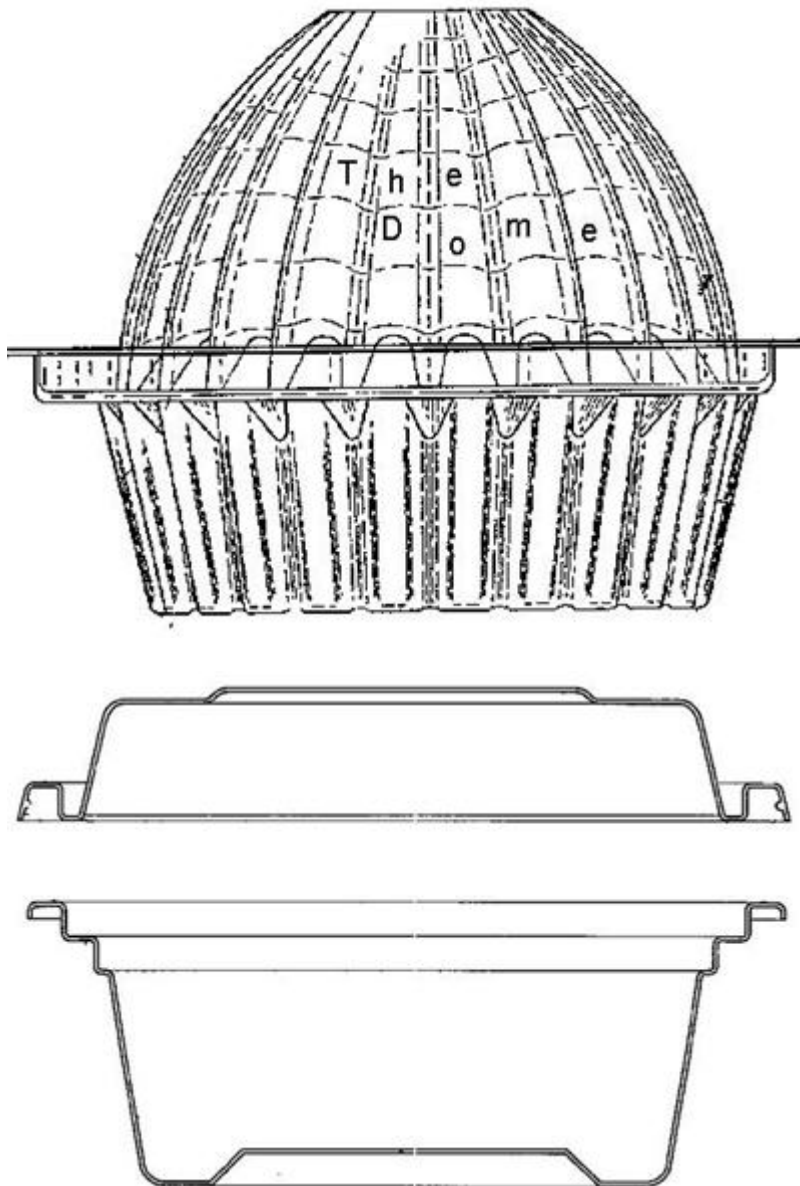

B65D 2543/00361

placed on a tray like container

Definition statement

This place covers:

Illustrative example of subject matter classified in this group:

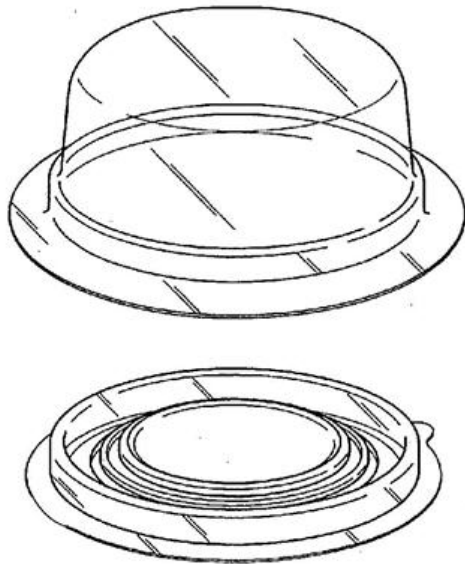
**B65D 2543/0037**

Flexible or deformable

Definition statement

This place covers:

Illustrative example of subject matter classified in this group:

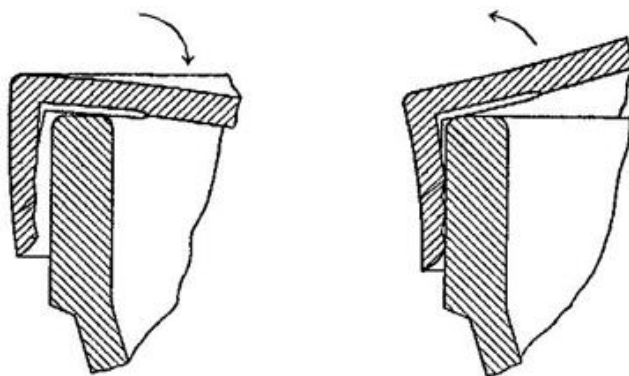
**References****Limiting references**

This place does not cover:

Hinged lids made of two (or more) hinged parts	B65D 43/161
--	-----------------------------

Informative references

Attention is drawn to the following places, which may be of interest for search:

Made of two parts (or more) hinged one to another	B65D 2543/00379
---	---------------------------------

B65D 2543/00379

hinged or articulated, i.e. made of two or more parts hinged one to another

Definition statement

This place covers:

Illustrative example of subject matter classified in this group:

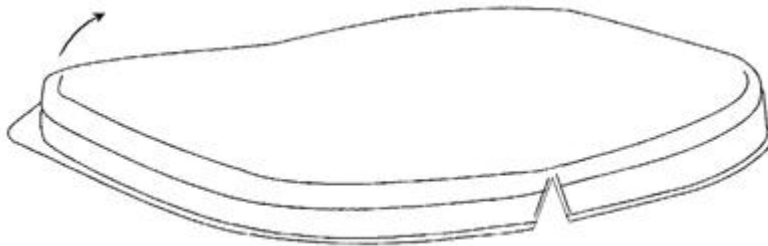
**B65D 2543/00388**

Bent or angled, i.e. central part presents two main planes

Definition statement

This place covers:

Illustrative example of subject matter classified in this group:

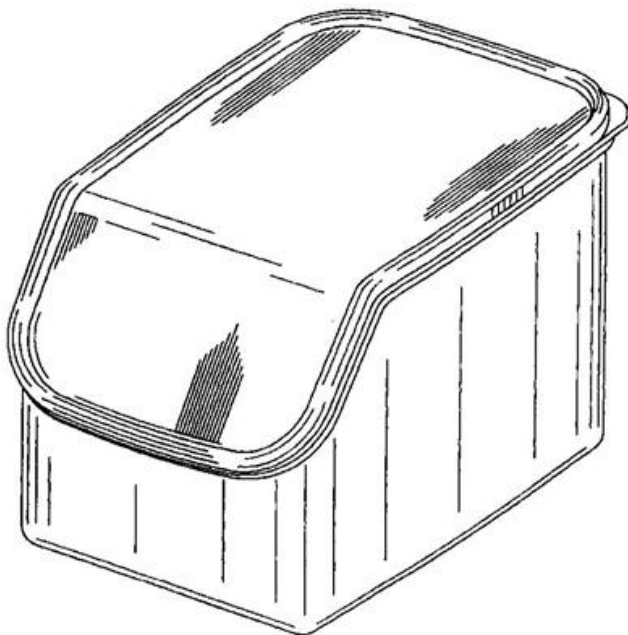

B65D 2543/00398

Reinforcing ribs in the central part of the closure

Definition statement

This place covers:

Illustrative example of subject matter classified in this group:

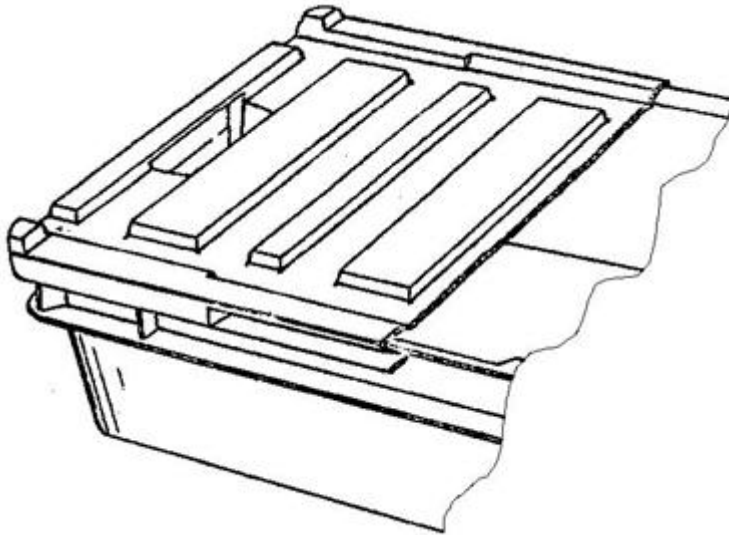

B65D 2543/00407

radial

Definition statement

This place covers:

Illustrative example of subject matter classified in this group:

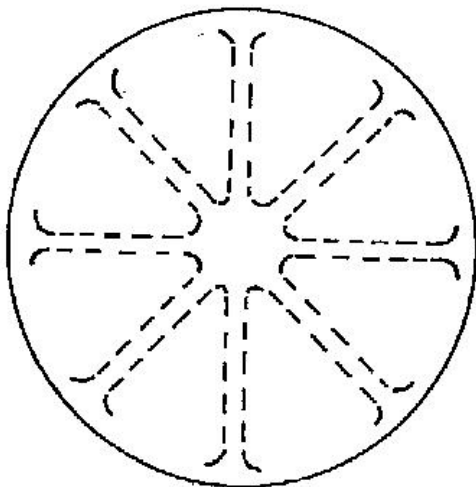

B65D 2543/00416

circular

Definition statement

This place covers:

Illustrative example of subject matter classified in this group:

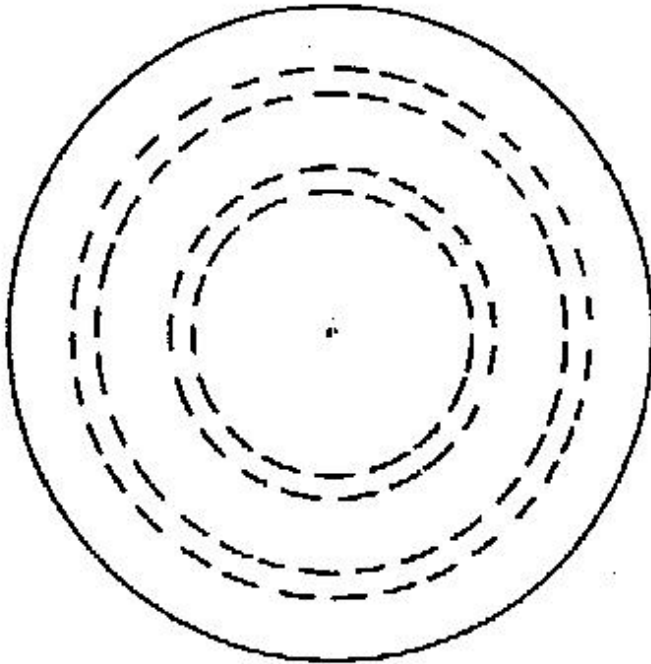

B65D 2543/00425

Lids or covers welded or adhered to the container

Definition statement

This place covers:

Illustrative example of subject matter classified in this group:

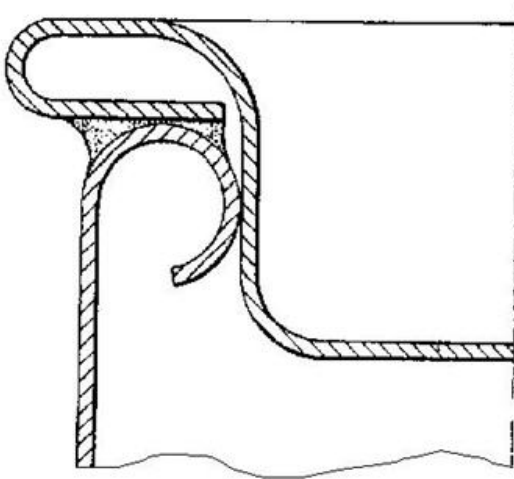

B65D 2543/00435

Lids secured to an intermediate ring or like annular member fixed to the container mouth

Definition statement

This place covers:

Illustrative example of subject matter classified in this group:

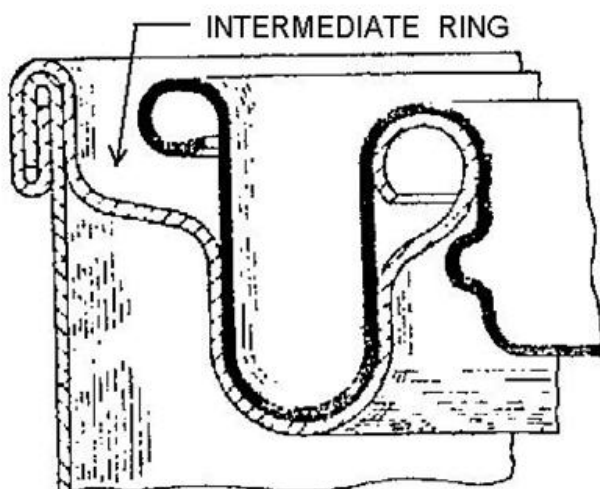

References

Informative references

Attention is drawn to the following places, which may be of interest for search:

Local reinforcements	B65D 7/48
----------------------	---------------------------

B65D 2543/00462

peripheral U-shaped channel of the lid

Definition statement

This place covers:

Illustrative example of subject matter classified in this group:

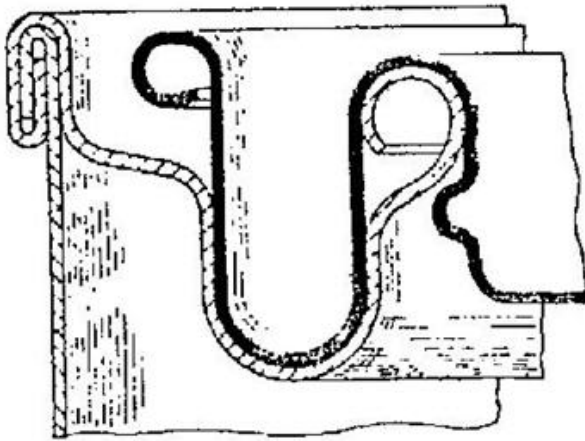

B65D 2543/00472

Skirt

Definition statement

This place covers:

Illustrative example of subject matter classified in this group:

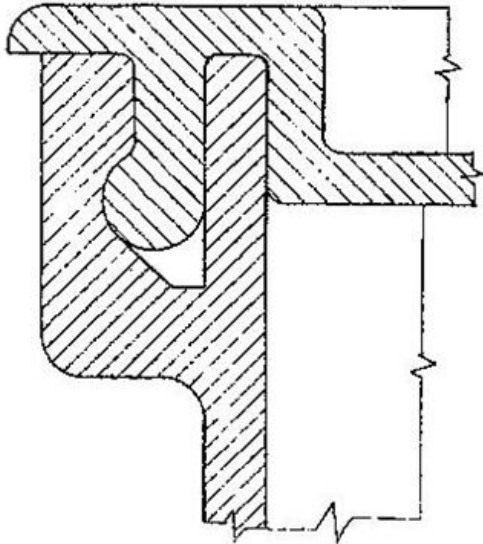

B65D 2543/0049

on the inside, or a part turned to the inside of the mouth of the container

Definition statement

This place covers:

Illustrative example of subject matter classified in this group:

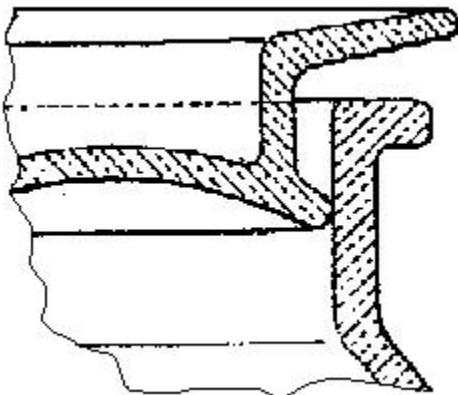

B65D 2543/005

both cup and skirt

Definition statement

This place covers:

Illustrative example of subject matter classified in this group:

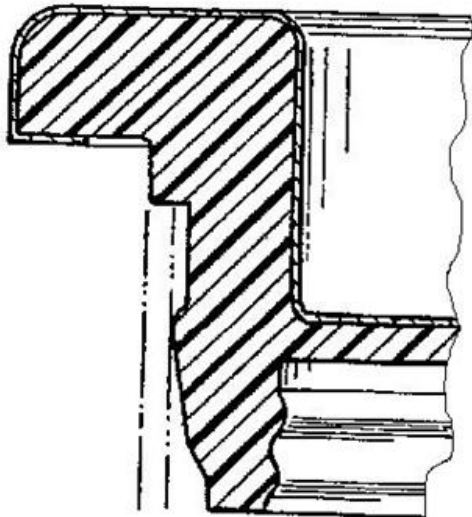

B65D 2543/00509

Cup

Definition statement

This place covers:

Illustrative example of subject matter classified in this group:

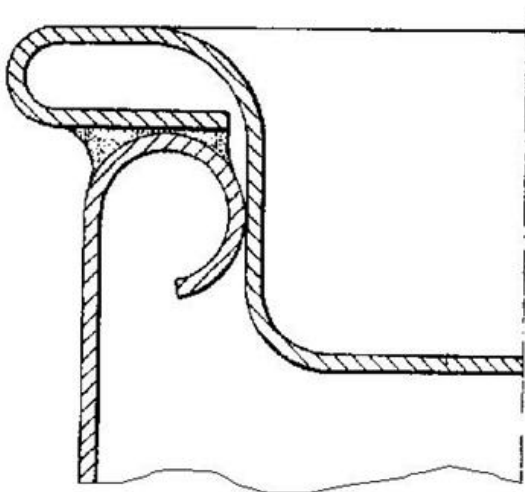

B65D 2543/00518

Skirt

Definition statement

This place covers:

Illustrative example of subject matter classified in this group:

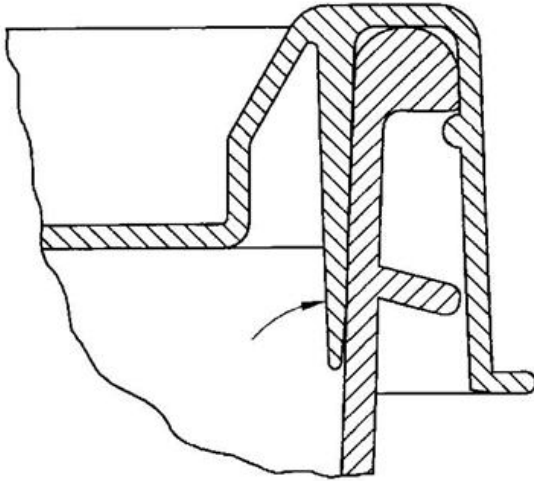

B65D 2543/00555

on both the inside and the outside

Relationships with other classification places

Documents must also have the codes [B65D 2543/0049+](#) and [B65D 2543/00537](#).

B65D 2543/00564

indirect by means of a gasket or similar intermediate ring

Definition statement

This place covers:

Illustrative example of subject matter classified in this group:

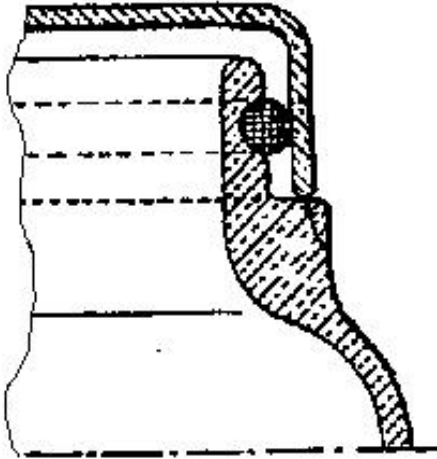

B65D 2543/00583

Means for limiting the axial insertion of the lid on the container

Definition statement

This place covers:

Illustrative example of subject matter classified in this group:

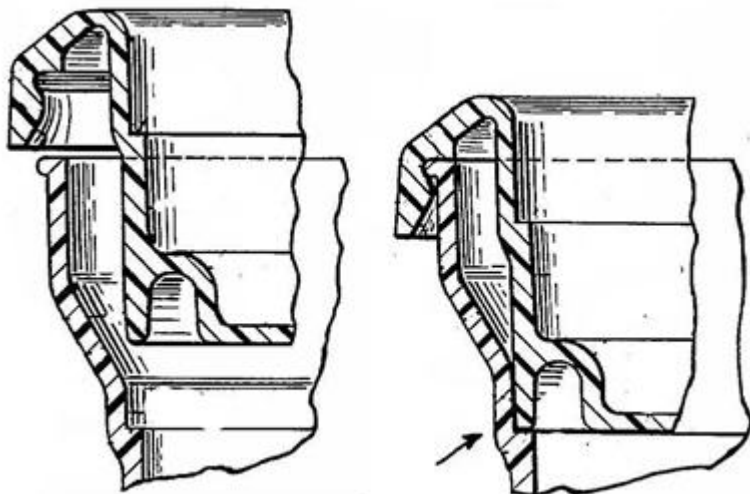

B65D 2543/0062

Groove or hollow bead

Definition statement

This place covers:

Illustrative example of subject matter classified in this group:

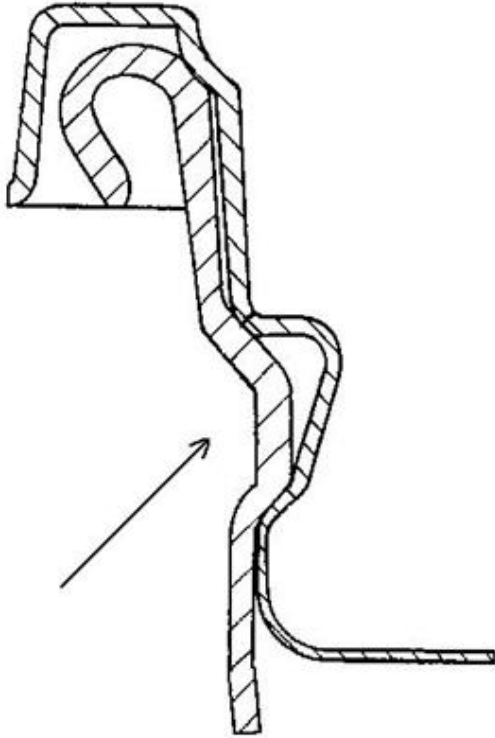

B65D 2543/00629

Massive bead

Definition statement

This place covers:

Illustrative example of subject matter classified in this group:

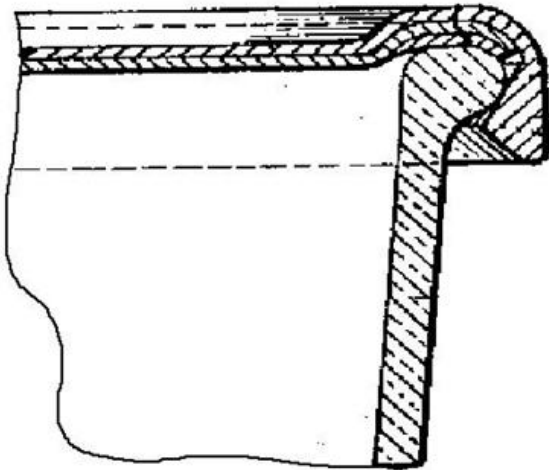

B65D 2543/00638

Rolled edge

Definition statement

This place covers:

Illustrative example of subject matter classified in this group:

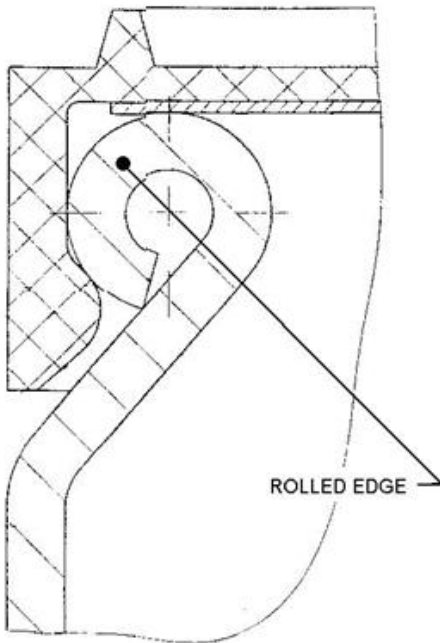

B65D 2543/00648

Flange or lip

Definition statement

This place covers:

Illustrative example of subject matter classified in this group:

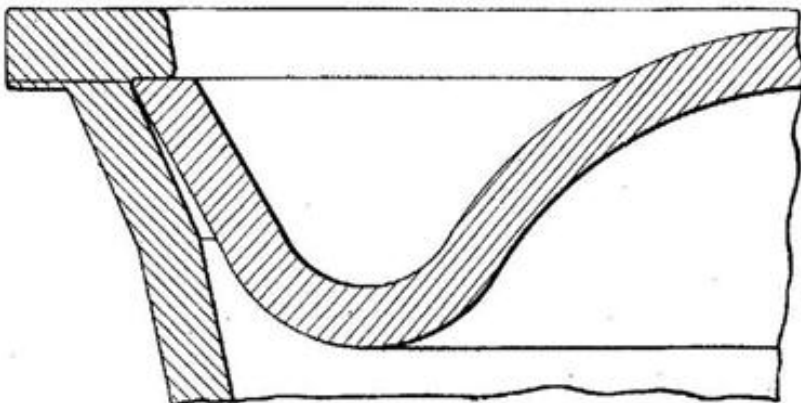

B65D 2543/00657

U-shaped or inverted U

Definition statement

This place covers:

Illustrative example of subject matter classified in this group:

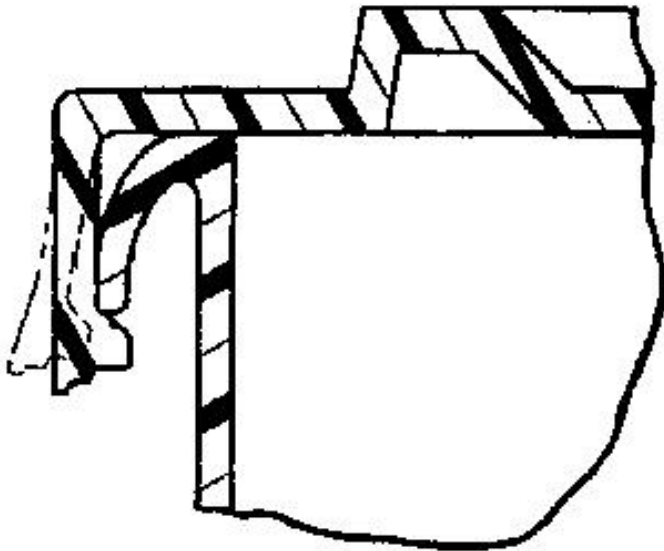

B65D 2543/00666

Hole

Definition statement

This place covers:

Illustrative example of subject matter classified in this group:

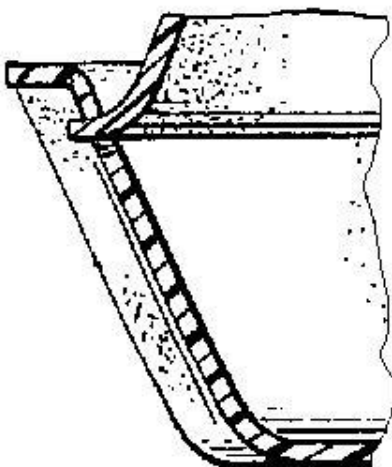

B65D 2543/00731

Groove or hollow bead

Definition statement

This place covers:

Illustrative example of subject matter classified in this group:

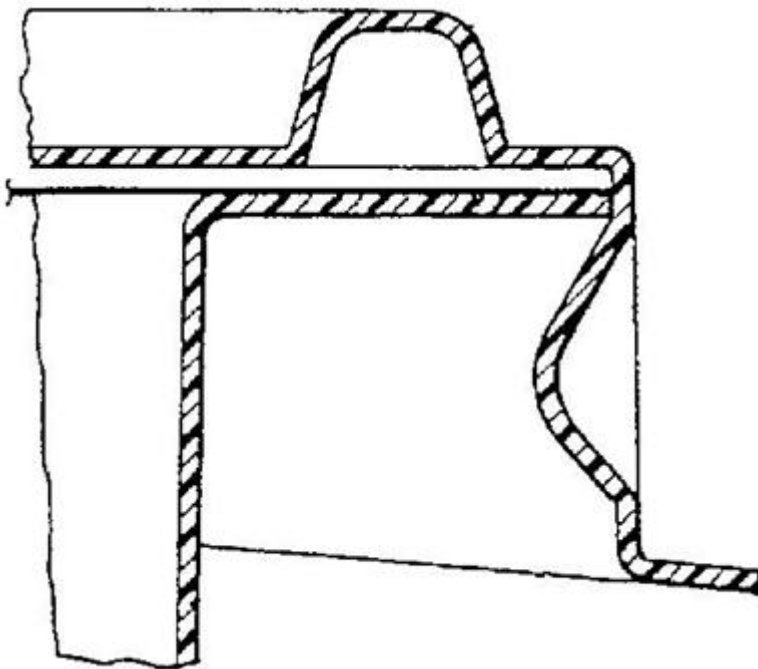
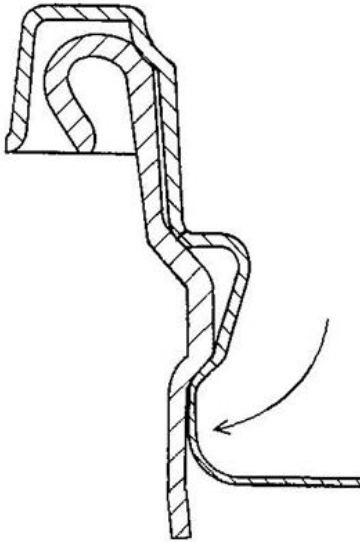

B65D 2543/0074

Massive bead

Definition statement

This place covers:

Illustrative example of subject matter classified in this group:

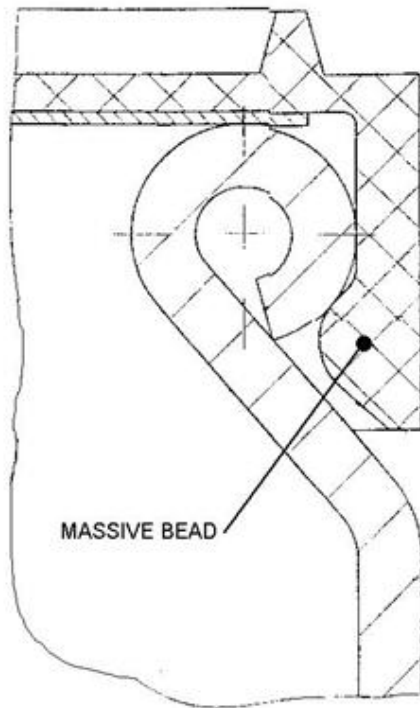

B65D 2543/0075

Rolled edge

Definition statement

This place covers:

Illustrative example of subject matter classified in this group:

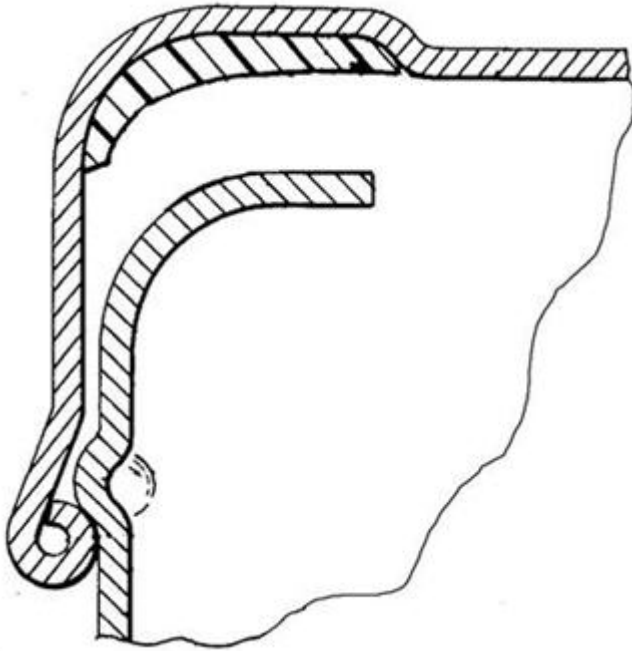

B65D 2543/00768

U-shaped or inverted U

Definition statement

This place covers:

Illustrative example of subject matter classified in this group:

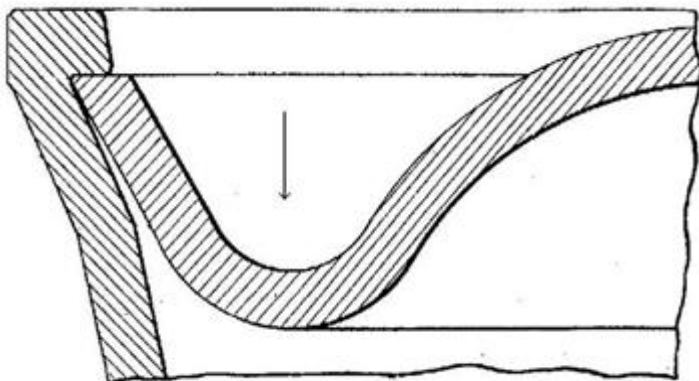

B65D 2543/00777

Hole

Definition statement

This place covers:

Illustrative example of subject matter classified in this group:

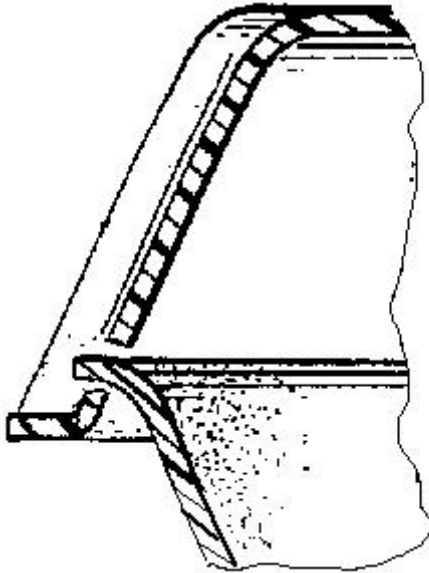

B65D 2543/00805

Segments

Definition statement

This place covers:

Illustrative example of subject matter classified in this group:

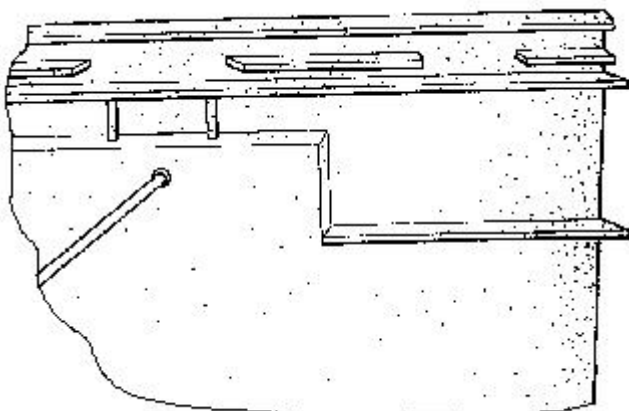

B65D 2543/00842**outside of the lid****Definition statement***This place covers:*

Illustrative example of subject matter classified in this group:

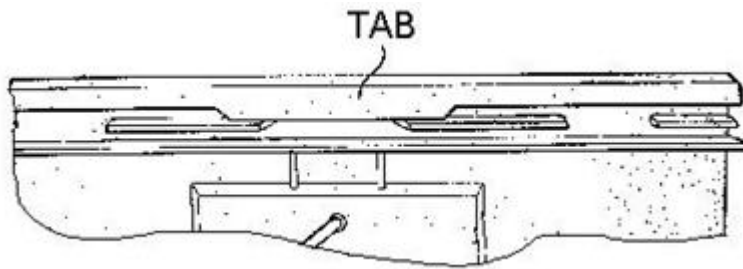
**B65D 2543/00851****on the central part of the lid****Definition statement***This place covers:*

Illustrative example of subject matter classified in this group:

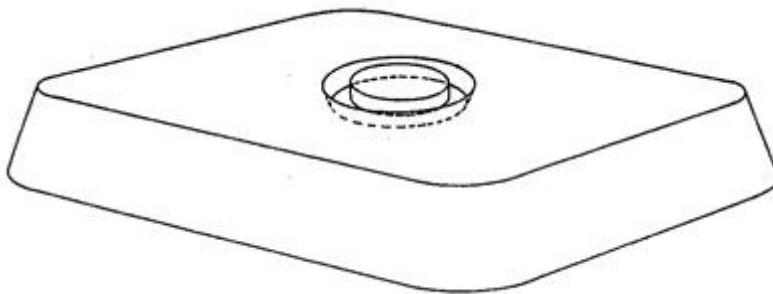
**References****Limiting references***This place does not cover:*

Facilitating lifting or suspending of the container

[B65D 51/242](#)

B65D 2543/0087**outside of the lid****Definition statement***This place covers:*

Illustrative example of subject matter classified in this group:

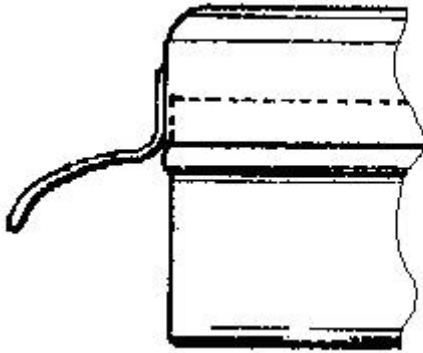
**B65D 2543/00879****on the central part of the lid****Definition statement***This place covers:*

Illustrative example of subject matter classified in this group:

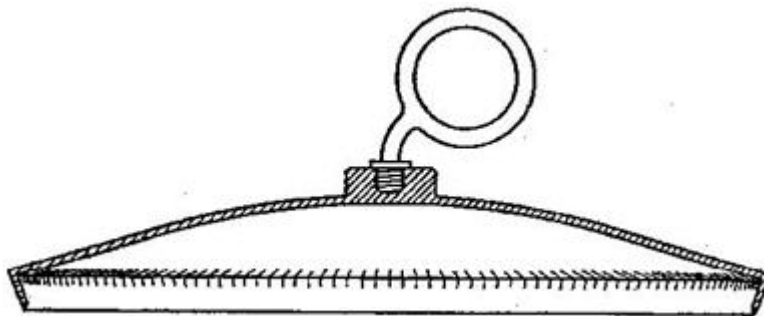
**References****Limiting references***This place does not cover:*

Facilitating lifting or suspending of the container	B65D 51/242
---	-----------------------------

Glossary of terms*In this place, the following terms or expressions are used with the meaning indicated:*

Central part	part covering the opening of the container
--------------	--

B65D 2543/00888**by applying lever forces****References*****Informative references****Attention is drawn to the following places, which may be of interest for search:*

By means of a coin or other tool on grooves or recesses on container or lid	B65D 2543/00898
- directly on two elements of container and lid respectively (GB316200)	B65D 2543/00907

B65D 2543/00898**by means of a coin or other tool in recesses or similar on container or lid****Definition statement***This place covers:*

Illustrative example of subject matter classified in this group:

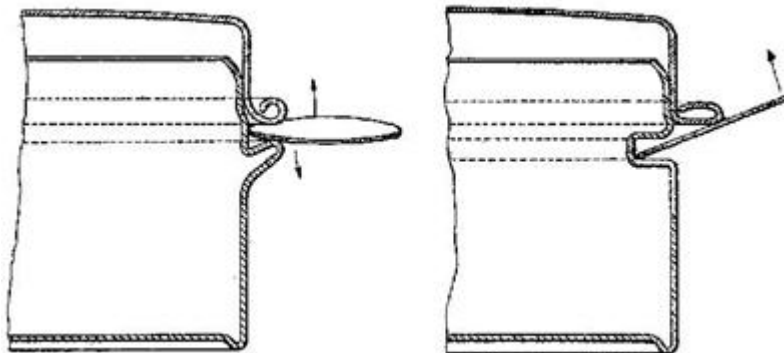
**References*****Limiting references****This place does not cover:*

Child-proof closures	B65D 50/067
----------------------	-----------------------------

B65D 2543/00907

directly on two elements of container and lid respectively, i.e. using the fingers

Definition statement

This place covers:

Illustrative example of subject matter classified in this group:

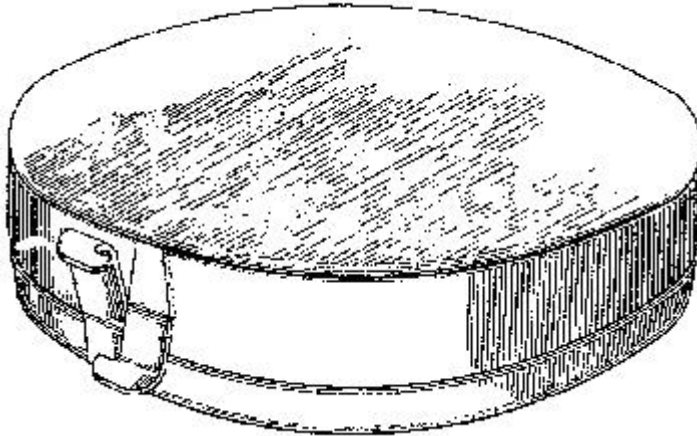

B65D 2543/00916

downward vertical pressure in order to tilt the opposite side of the lid

Definition statement

This place covers:

Illustrative example of subject matter classified in this group:

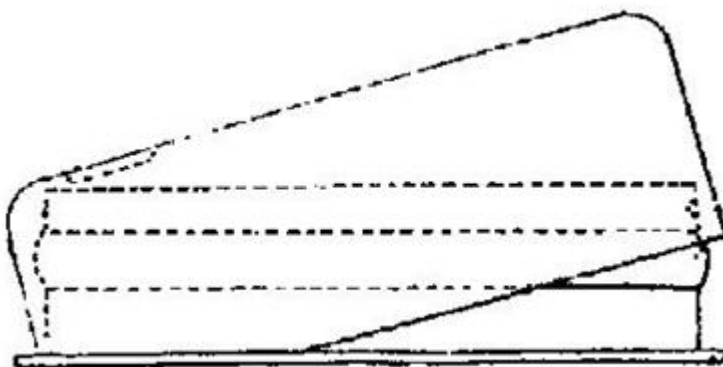

B65D 2543/00925

by applying inwardly directed pressure at two horizontally opposed points

Definition statement

This place covers:

Illustrative example of subject matter classified in this group:

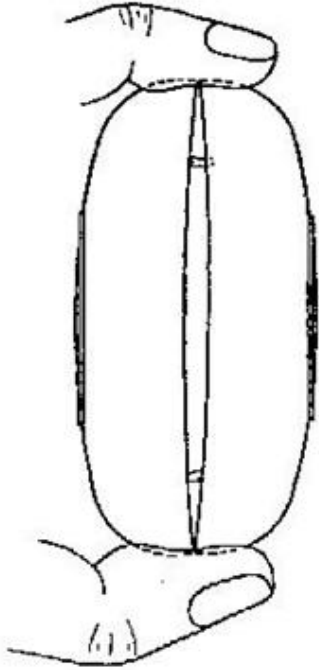

B65D 2543/00935**by depressing the central part at least locally****Definition statement***This place covers:*

Illustrative example of subject matter classified in this group:

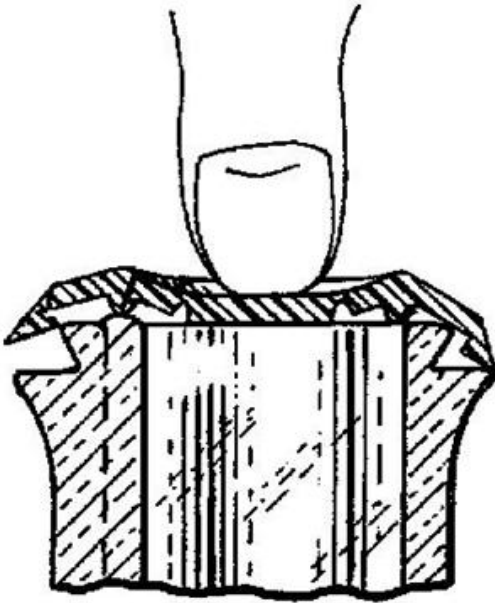
**Glossary of terms***In this place, the following terms or expressions are used with the meaning indicated:*

Central part	part covering the opening of the container
--------------	--

B65D 2543/00944**Located only on the container, e.g. recesses****Definition statement***This place covers:*

Illustrative example of subject matter classified in this group:

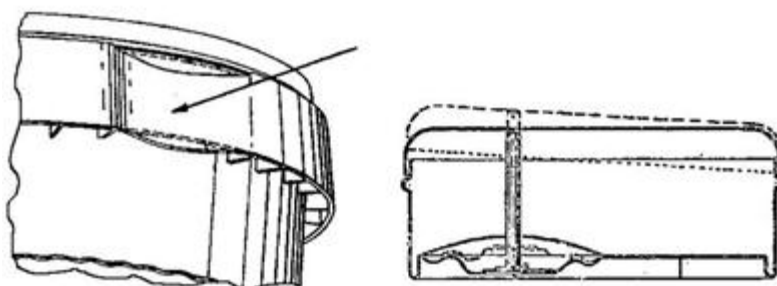

B65D 2543/00953**Sealing means****References****Limiting references***This place does not cover:*

More general application of sealing means	B65D 2251/20
---	------------------------------

B65D 2543/00962**inserted****References****Limiting references***This place does not cover:*

More general application of sealing means	B65D 2251/205
---	-------------------------------

B65D 2543/00972**Collars or rings****References****Limiting references***This place does not cover:*

More general application of sealing means	B65D 2251/205
---	-------------------------------

B65D 2543/00981**Discs****References****Limiting references***This place does not cover:*

More general application of sealing means	B65D 2251/205
---	-------------------------------

B65D 2563/102

having an integral securing member with only one locking position, i.e. the strap cannot be tightened

Definition statement

This place covers:

Illustrative example of subject matter classified in this group:

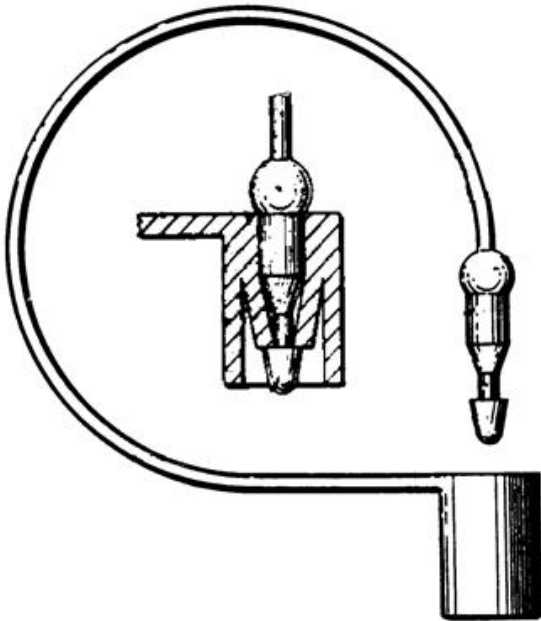

B65D 2563/103

details of the male locking member, e.g. locking teeth on the strap

Definition statement

This place covers:

Illustrative example of subject matter classified in this group:

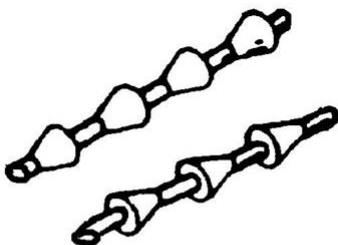

B65D 2563/106**formed as a ladder-like structure****Definition statement***This place covers:*

Illustrative example of subject matter classified in this group:

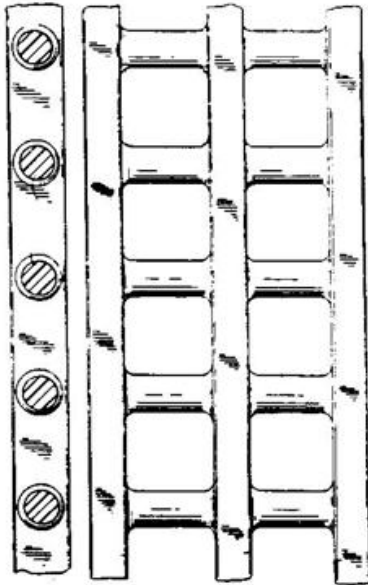
**B65D 2571/00043****Intermediate plates or the like****References****Informative references***Attention is drawn to the following places, which may be of interest for search:*

Packages formed by enclosing articles or materials in preformed containers comprising several inner stacked containers with intermediate trays, plates	B65D 2577/046
Packages formed by enclosing articles or materials in preformed containers comprising several inner containers stacked and arranged side by side with intermediate trays	B65D 2577/048

B65D 2571/00055**Clapping elements, also placed on the side****References****Limiting references***This place does not cover:*

Bundles surrounded by carton blanks	B65D 2571/00037
-------------------------------------	---------------------------------

B65D 2571/00067

Local maintaining elements, e.g. partial packaging, shrink packaging, shrink small bands

References**Limiting references**

This place does not cover:

Palletisable loads intermediate plates or the like	B65D 2571/00043
Clapping elements, also placed on the side	B65D 2571/00055

B65D 2571/00074

Stabilising or reinforcing columns

References**Limiting references**

This place does not cover:

Frames, corner posts or pallet converters	B65D 19/385
---	-----------------------------

B65D 2571/0008

Load supporting elements

References**Informative references**

Attention is drawn to the following places, which may be of interest for search:

Elements for spacing platforms from supporting surface	B65D 19/40
--	----------------------------

B65D 2571/00104

Forms or jigs for use in making the load

References**Limiting references**

This place does not cover:

Machines, apparatus or devices for, or methods of, packaging articles or materials; unpacking	B65B
---	----------------------

B65D 2571/00111**Arrangements of flexible binders****Special rules of classification**This code is same as [B65D 71/02](#) but used only for palletisable loads**B65D 2571/00117****with protecting or supporting elements arranged between binder and articles or materials, e.g. for preventing chafing of binder****Special rules of classification**This code is same as [B65D 71/02](#) but used only for palletisable loads**B65D 2571/00259****inwardly folded tabs, i.e. elements substantially narrower than the corresponding package dimension****References****Limiting references***This place does not cover:*

Interlocked bundling wrappers or trays	B65D 2571/00154
--	---------------------------------

B65D 2571/00555**Wrapper opening devices****References****Limiting references***This place does not cover:*

Partitions inserted the wrapper	B65D 2571/00401
Shape of the formed wrapper with inserted end walls	B65D 2571/00777

B65D 2571/00666**formed from two or more sheets****References****Limiting references***This place does not cover:*

Partitions inserted the wrapper	B65D 2571/00401
Shape of the formed wrapper with inserted end walls	B65D 2571/00777

B65D 2571/00858

Devices for locating the wrapped bundle in a container, e.g. in a bottle crate

References

Limiting references

This place does not cover:

Details of crates	B65D 2571/00129
-------------------	---------------------------------

B65D 2575/361

Details

Special rules of classification

Not used

B65D 2575/363

by sliding one sheet relative to the other

Definition statement

This place covers:

Illustrative example of subject matter classified in this group:

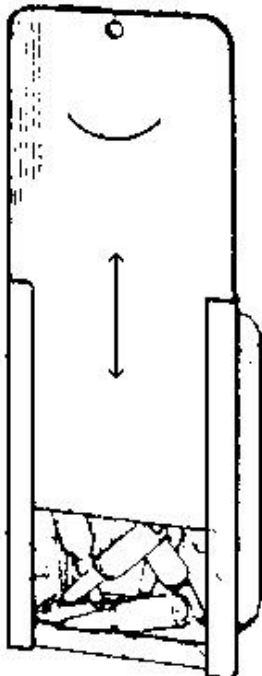

B65D 2575/365

partially or totally releasing one sheet from the other

Definition statement

This place covers:

Illustrative example of subject matter classified in this group:

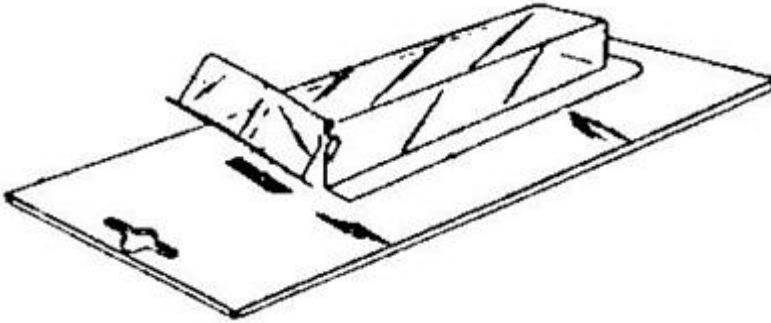

B65D 2575/366

through a preformed opening in the recessed sheet, e.g. the opening being defined by weakened lines

Definition statement

This place covers:

Illustrative example of subject matter classified in this group:

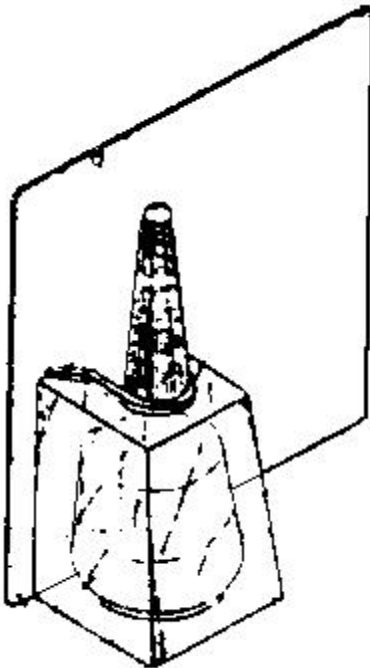

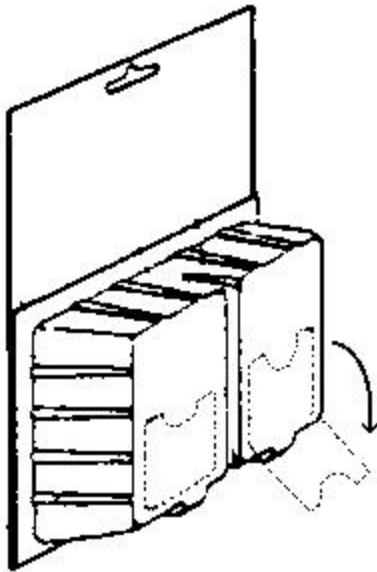

B65D 2575/367

through a preformed opening in the flat sheet, e.g. the opening being defined by weakened lines

Definition statement

This place covers:

Illustrative example of subject matter classified in this group:

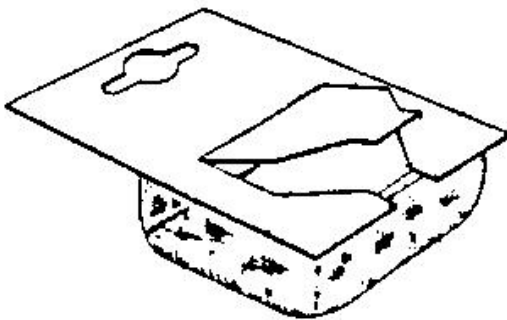

B65D 2575/583

the non-integral spout having an elongate cross-sectional shape, e.g. canoe or boat shaped

Definition statement

This place covers:

Illustrative example of subject matter classified in this group:



B65D 2575/586**with means for reclosing****Definition statement***This place covers:*

Illustrative example of subject matter classified in this group:

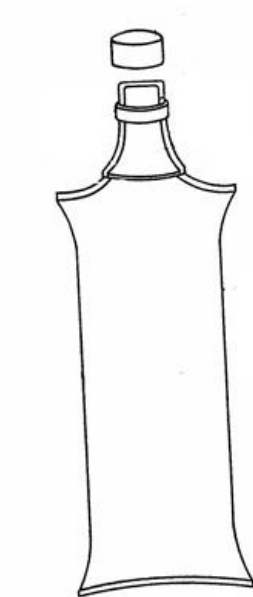
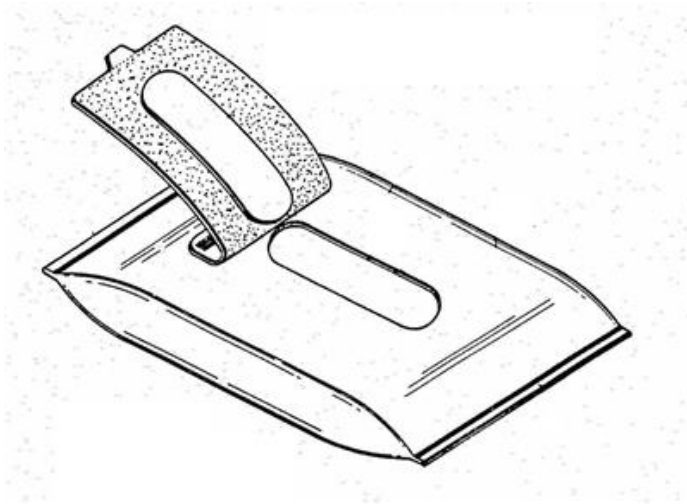
**References****Limiting references***This place does not cover:*

Articles or materials enclosed between two opposed sheets or blanks having their margins united with reclosing means
--

B65D 2575/368

B65D 2577/2008

Rigid cutting or tearing devices

References

Informative references

Attention is drawn to the following places, which may be of interest for search:

Rigid cutting or tearing devices	B65D 77/40
----------------------------------	----------------------------

B65D 2577/2083

in container flange

Definition statement

This place covers:

Illustrative example of subject matter classified in this group:

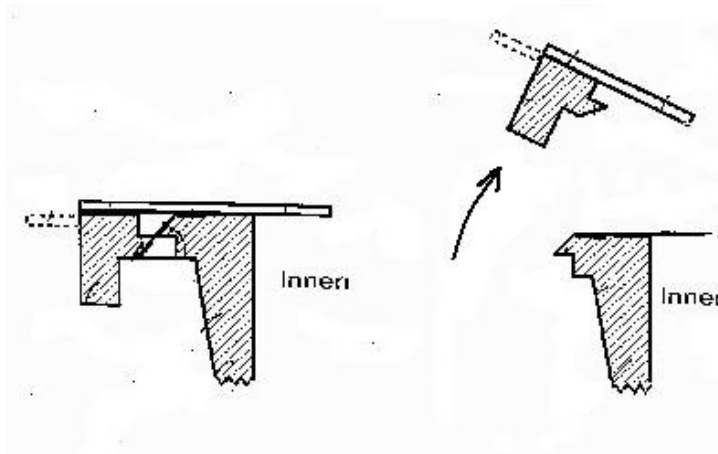

B65D 2577/2091**in cover****Definition statement***This place covers:*

Illustrative example of subject matter classified in this group:

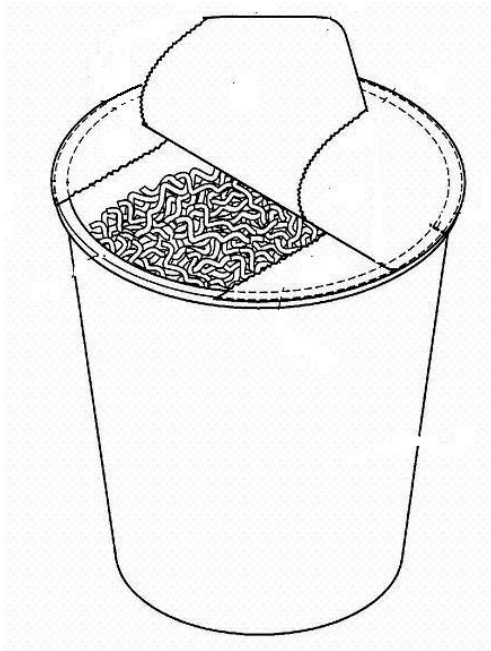
**References****Limiting references***This place does not cover:*

Pre-cut holes or weakened zones for draining or discharging the liquid contents	B65D 2231/025
---	-------------------------------

B65D 2581/057

Edge protectors adapted to protect the circular edge of rolls of material, e.g. coils of sheet metal

Definition statement

This place covers:

Illustrative example of subject matter classified in this group:

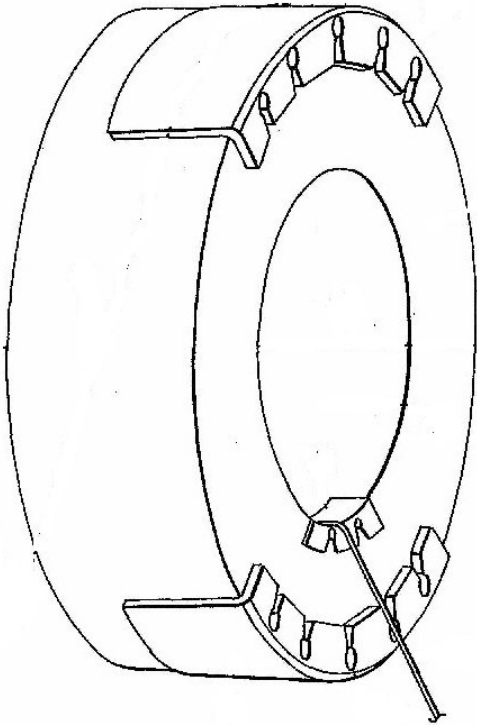

B65D 2581/058

Edge or corner protectors connected to each other by separate elements

Definition statement

This place covers:

Illustrative examples of subject matter classified in this group:

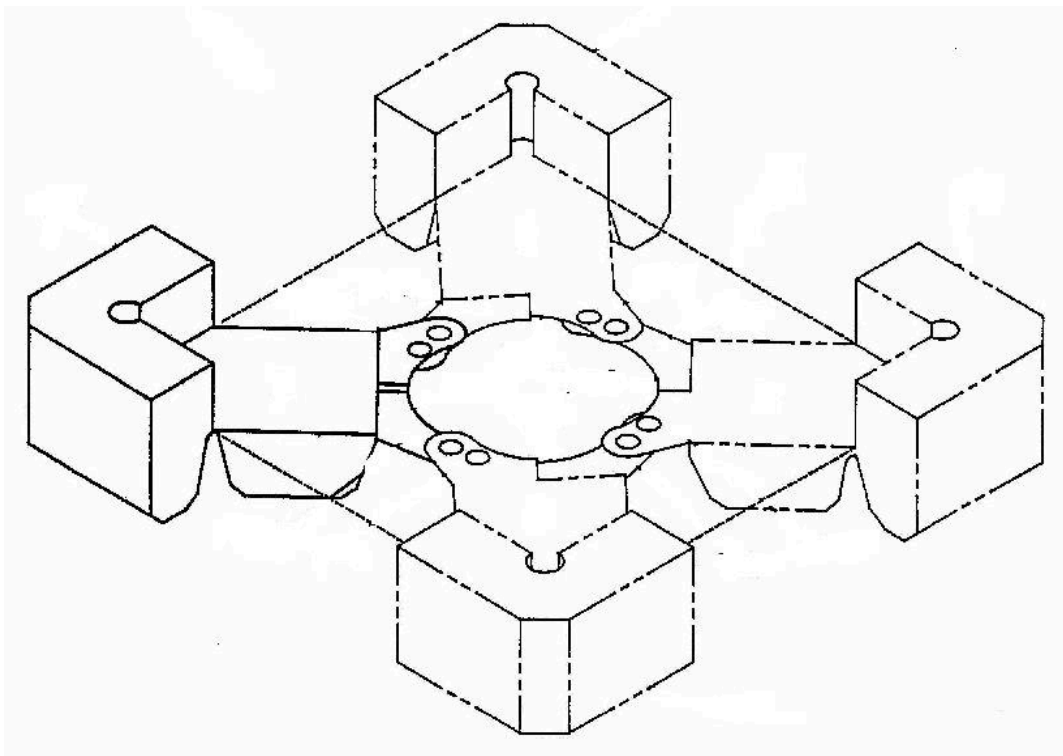
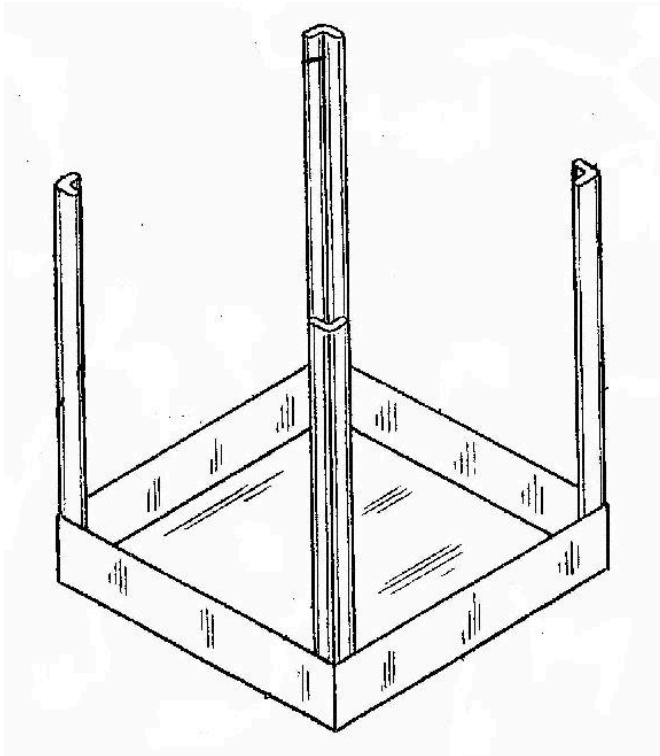

B65D 2581/3406**Pizza or bread****References****Limiting references***This place does not cover:*

	81/36P
--	---------------

B65D 2581/3409**Brewing coffee or tea****Definition statement***This place covers:*

Illustrative example of subject matter classified in this group:

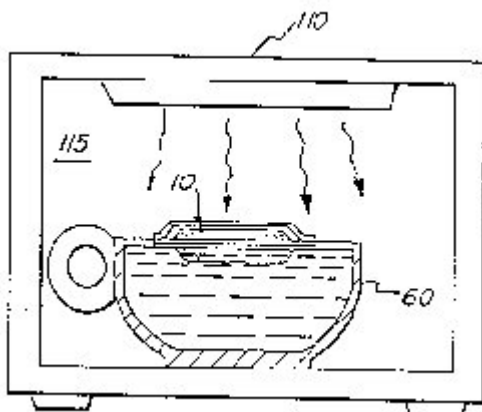
**B65D 2581/3412****Cooking fried food ([B65D 2581/3416](#) and [B65D 2581/3417](#) take precedence)****References****Limiting references***This place does not cover:*

Cooking meat products	B65D 2581/3416
Bacon	B65D 2581/3417

B65D 2581/3413

Fish sticks or french fries

Definition statement

This place covers:

Illustrative example of subject matter classified in this group:

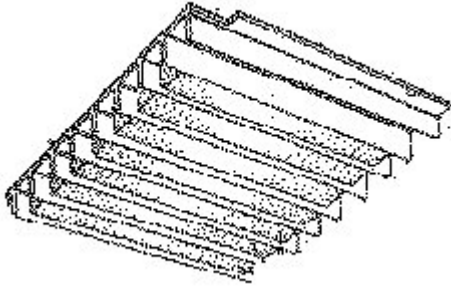

B65D 2581/3421

Cooking pop-corn

Definition statement

This place covers:

Illustrative example of subject matter classified in this group:

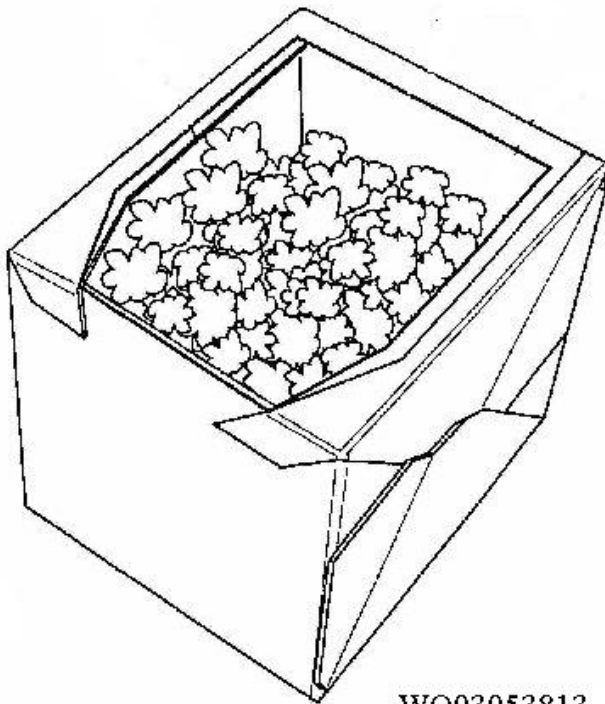

WO03053813

References

Limiting references

This place does not cover:

Pop-corn bags	B65D 81/3469
---------------	------------------------------

B65D 2581/3431

the secondary product, e.g. fudge, being heated over ice-cream

Definition statement

This place covers:

Illustrative example of subject matter classified in this group:

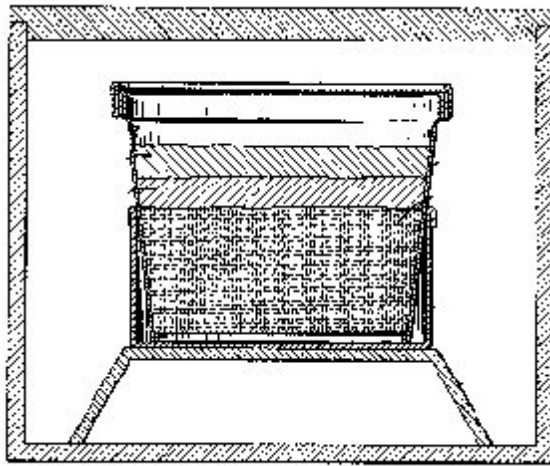

B65D 2581/3432

the secondary product, e.g. flavouring sauce, being enclosed in a second package

Definition statement

This place covers:

Illustrative example of subject matter classified in this group:

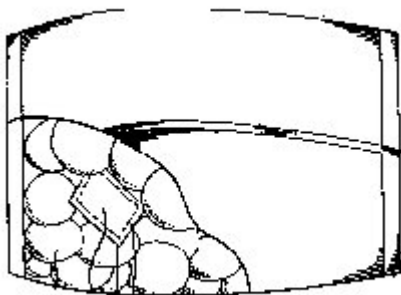

B65D 2581/344

Geometry or shape factors influencing the microwave heating properties

Definition statement

This place covers:

Illustrative example of subject matter classified in this group:

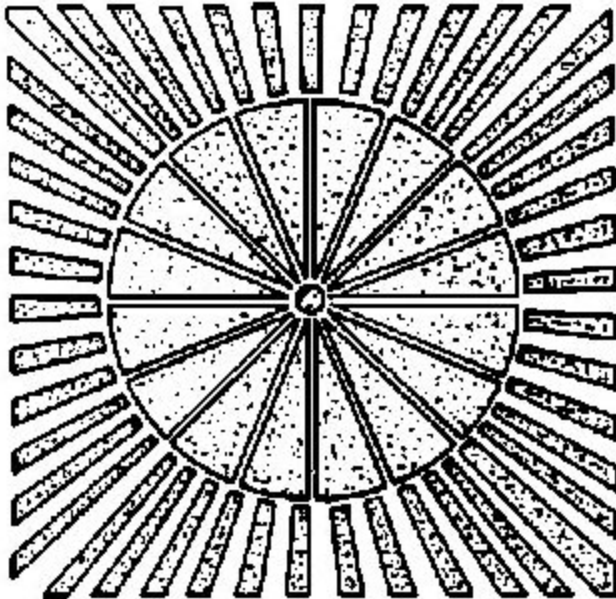

Special rules of classification

This code is always used in combination with the [B65D 2581/3486](#) codes.

B65D 2581/3441

3-D geometry or shape factors, e.g. depth-wise

Definition statement

This place covers:

Illustrative example of subject matter classified in this group:

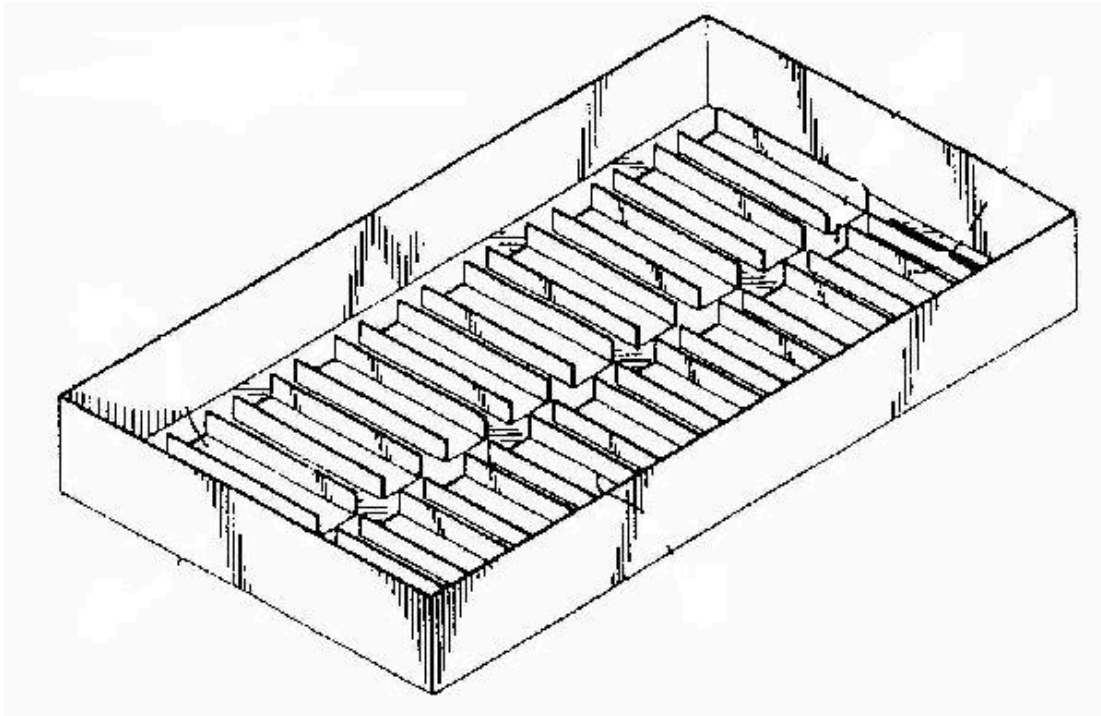

Special rules of classification

This code is always used in combination with the [B65D 2581/3486](#) codes.

B65D 2581/3443

Shape or size of microwave reactive particles in a coating or ink

Special rules of classification

This code is always used in combination with the [B65D 2581/3486](#) codes.

B65D 2581/3452

Packages having a plurality of microwave reactive layers, i.e. multiple or overlapping microwave reactive layers

Definition statement

This place covers:

Illustrative example of subject matter classified in this group:

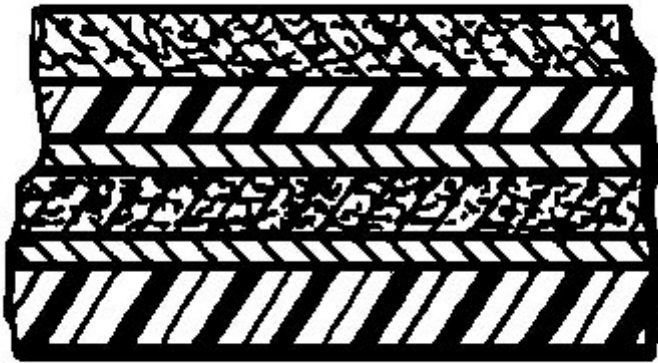

B65D 2581/3456

Means for holding the contents at a distance from the base of the package, e.g. raised islands or protrusions ([B65D 2581/3459](#) takes precedence)

Definition statement

This place covers:

Illustrative example of subject matter classified in this group:

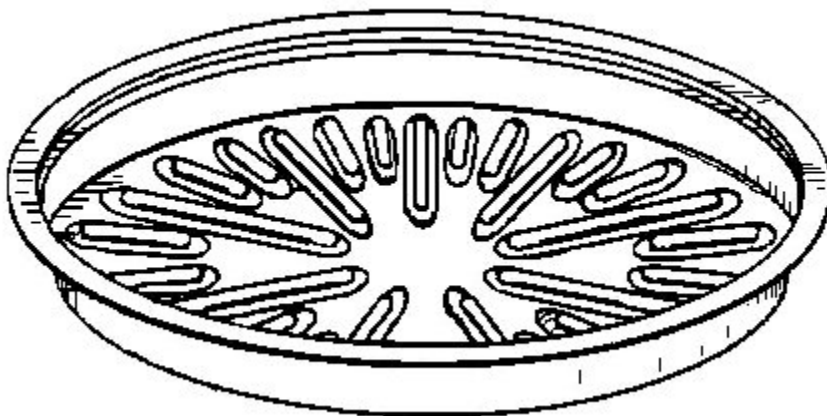

References

Limiting references

This place does not cover:

Means for holding the package at a distance from the microwave oven floor	B65D 2581/3459
---	--------------------------------

B65D 2581/3458

Convective heating chambers, e.g. hot air channels

Definition statement

This place covers:

Illustrative example of subject matter classified in this group:

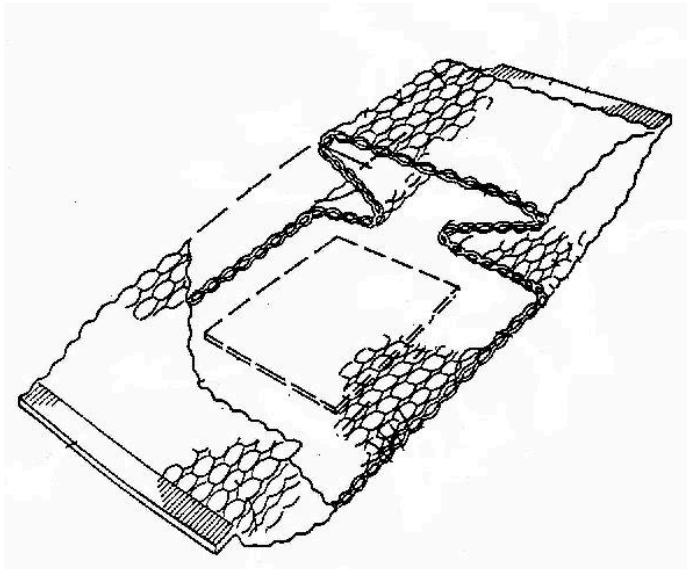

B65D 2581/346

integral to the package, e.g. the package is transformed into a stand

Definition statement

This place covers:

Illustrative example of subject matter classified in this group:

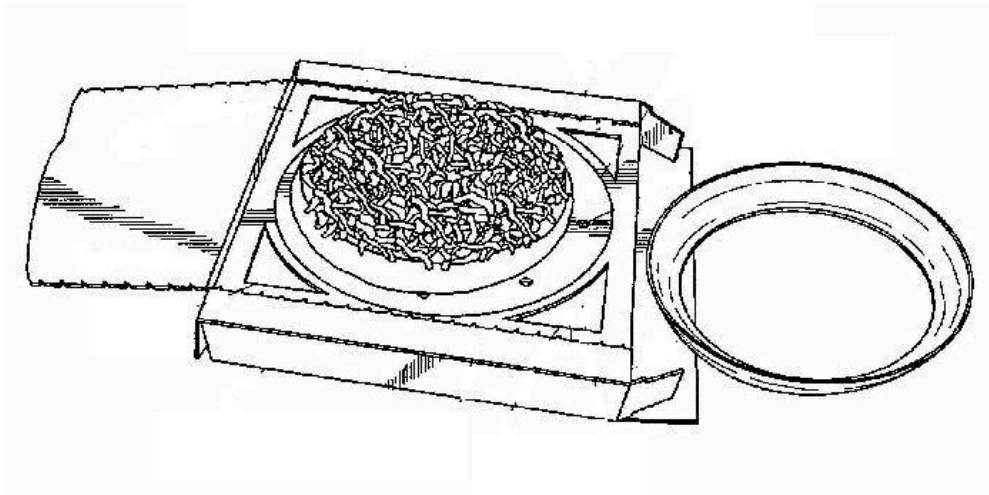

B65D 2581/3462

separate from the package, e.g. separate stands

Definition statement

This place covers:

Illustrative example of subject matter classified in this group:

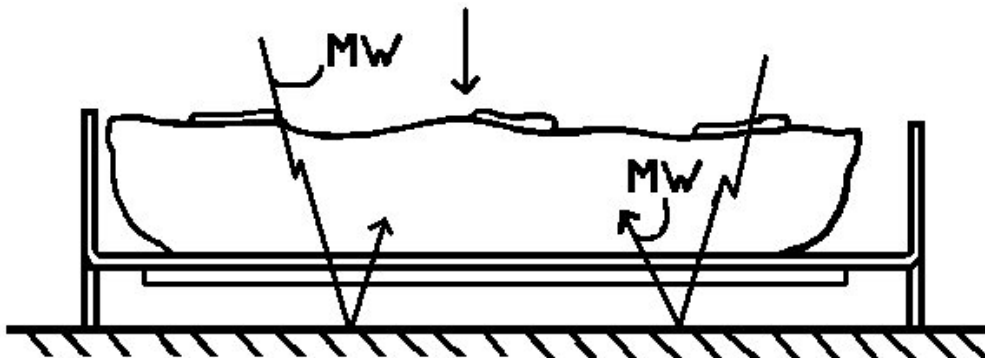

B65D 2581/3487

Reflection, Absorption and Transmission [RAT] properties of the microwave reactive package

Definition statement

This place covers:

Illustrative example of subject matter classified in this group:

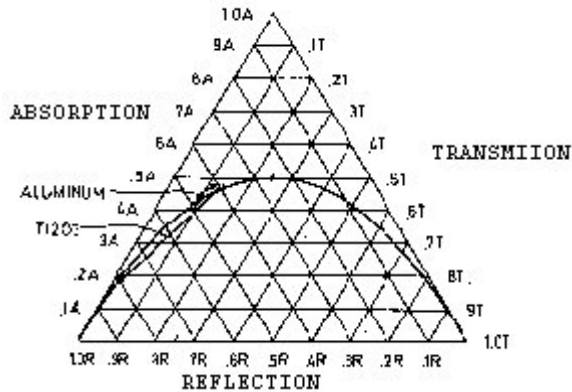

B65D 2583/005

Dispensers provided with a replaceable cartridge, recharge or pouch located within the dispenser

Definition statement

This place covers:

Illustrative example of subject matter classified in this group:

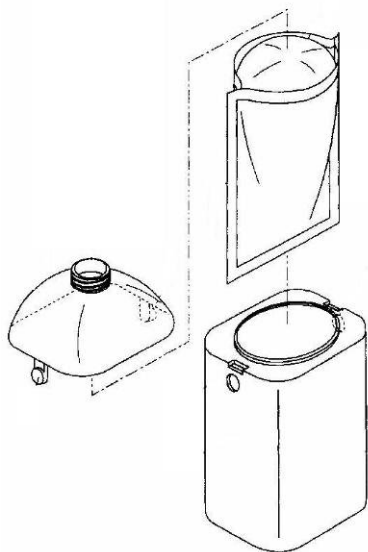

B65D 2583/04

For dispensing annular, disc-shaped or spherical or like small articles or tablets

Special rules of classification

NOT USED

B65D 2583/0459

Flat circular container with rotating parts

Special rules of classification

Documents which are not for the [B65D 83/0454](#) are classified here.

B65D 2583/0468

of drawer-and-shell type

References**Limiting references**

This place does not cover:

Flat container with slide cover	B65D 2583/0454
---------------------------------	--------------------------------

B65D 2583/0481

One reciprocating action, e.g. to or from

References**Limiting references**

This place does not cover:

One rotational action of a cylindrical, disc-like or sphere-like element around its own axis	B65D 2583/049
--	-------------------------------

B65D 2583/08

for dispensing thin flat articles in succession

Special rules of classification

Not used.

B65D 2583/082

Details relating to containers for dispensing thin flat articles in succession

Special rules of classification

Not used.

B65D 2583/087

with cutting edges being impregnated or coated

Definition statement

This place covers:

Illustrative example of subject matter classified in this group:

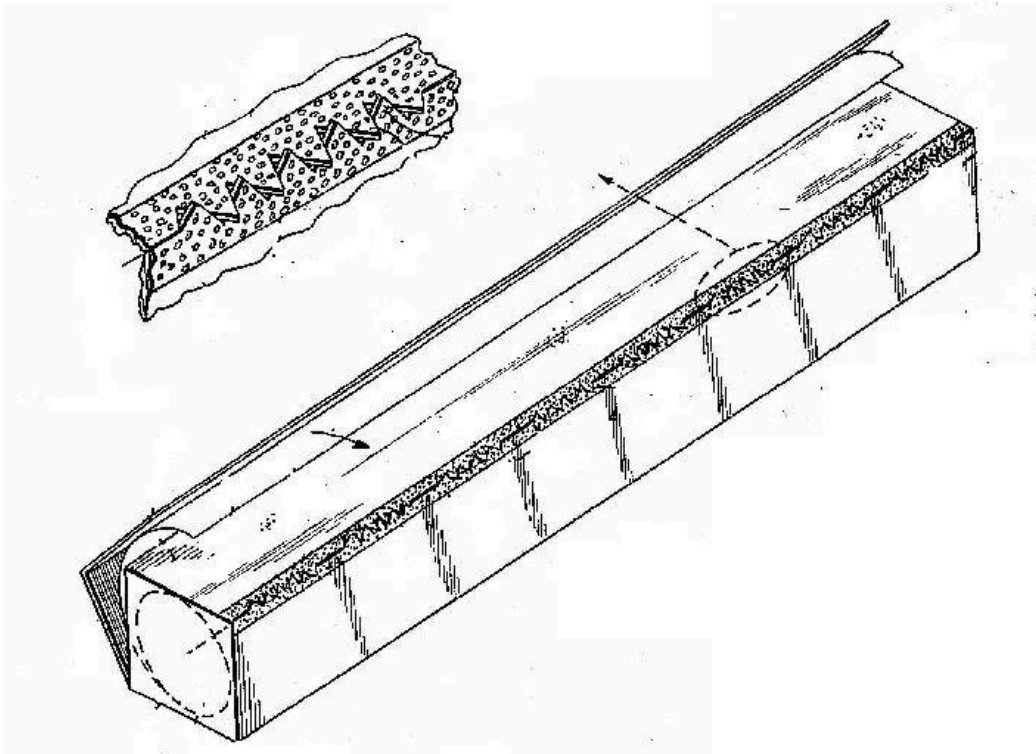
**B65D 2585/085**

Shirred sausage casings

References**Limiting references**

This place does not cover:

Shirred sausage casing details consult	A22C 13/023
--	-----------------------------

B65D 2585/366

Pizza

References**Informative references**

Attention is drawn to the following places, which may be of interest for search:

Packaging elements for cooking or heating Pizza (or bread foodstuffs)	B65D 2581/3406
---	--------------------------------

B65D 2585/545**Contact lenses****References****Limiting references**

This place does not cover:

Traditional contact lens cases, i.e. not used for packaging	A45C 11/005
---	-----------------------------

B65D 2585/56**for medicinal tablets or pills****References****Limiting references**

This place does not cover:

With means for dispensing	B65D 2583/04
---------------------------	------------------------------

B65D 2585/6882**vehicle parts****References****Informative references**

Attention is drawn to the following places, which may be of interest for search:

Wiper blades; wiper blades per se	B60S 1/38
-----------------------------------	---------------------------

B65D 2585/86

for electrical components (small electrical components attached to cards, sheets or webs [B65D 73/02](#); for articles particularly sensitive to damage by shock or pressure [B65D 2585/30](#); for ampoules, lamp bulbs, electronic valves or tubes [B65D 85/42](#))

Special rules of classification

B65D85/86 exists as IPC class

B65D 2585/88**Batteries****Special rules of classification**

B65D85/88 exists as IPC class