

B21F

WORKING OR PROCESSING OF METAL WIRE ({reducing diameter by} rolling of metal [B21B](#); by drawing, auxiliary operations used in connection with metal-working without essentially removing material [B21C](#); bundling articles [B65B 13/00](#))

Definition statement

This place covers:

Methods as well as devices relating to working or processing of metal wire, i.e. modifying, not manufacturing the wire:

Wire working methods characterized by their technology (e.g. bending, coiling, etc). These aspects are covered by [B21F 1/00-B21F 23/005](#)

Wire working methods characterized by the product made (e.g. barbed wire, wire network etc). These aspects are covered by [B21F 25/00-B21F 45/28](#)

Miscellaneous wire working and processing. These aspects are covered by [B21F 99/00](#)

References

Limiting references

This place does not cover:

Metal rolling methods of mills for making wire or material of like small cross-section	B21B 1/16
Manufacture of metal sheets, metal wire, metal rods, metal tubes by drawing	B21C 1/00
Devices for straightening wire or like work combined with or specially adapted for use in connection with drawing or winding machines or apparatus	B21C 19/00
Manufacture of bars or wires by metal working	B21C 37/04
Devices for cleaning metal products, e.g. wires , combined with or specially adapted for use with machines or apparatus provided in B21C	B21C 43/00
Winding-up, coiling or winding-off metal wires, metal band or other flexible metal material characterised by features relevant to metal processing only	B21C 47/00

Informative references

Attention is drawn to the following places, which may be of interest for search:

Jewellery; Bracelets: Other personal ornaments; coins	A44C
Working or processing of sheet metal or metal tubes, rods or profiles without essentially removing material; punching	B21D
Making needle, pins or nails	B21G
Making chains	B21L
Making alloys containing metallic or non-metallic fibres or filaments	C22C 47/00
Building	E04

Semi-conductor devices; electric solid state devices not other wise provided for	H01L
--	----------------------

B21F 1/00

Bending wire other than coiling; Straightening wire

Definition statement

This place covers:

Methods and devices for bending wire, i.e. forming discrete angles, as well as straightening, i.e. removing distortions.

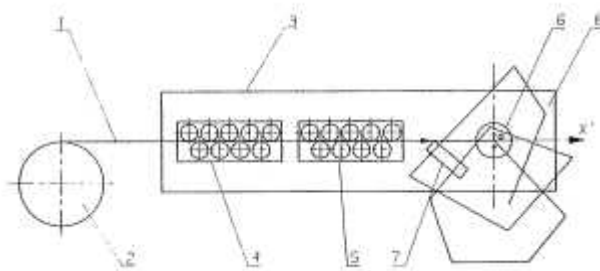

Source: WO9324254

B21F 3/00

Coiling wire into particular forms

Definition statement

This place covers:

Methods and devices for coiling wire, i.e. forming a continuous angle along the wire length.

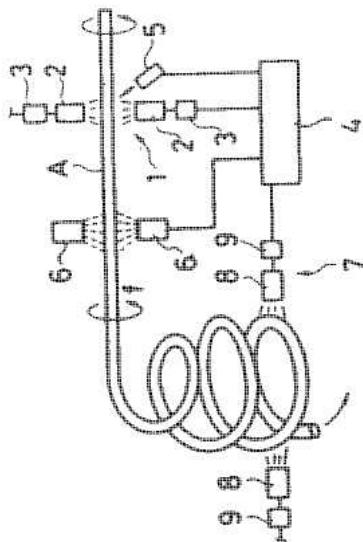

Source: JP58192643

References

Informative references

Attention is drawn to the following places, which may be of interest for search:

Making springs from wire	B21F 35/00
--------------------------	----------------------------

B21F 5/00

Upsetting wire {or pressing operations affecting the wire cross-section} (in the manufacture of nails or pins [B21G 3/12](#))

Definition statement

This place covers:

Methods and devices for enlarging a wire cross-section by applying an axial force.

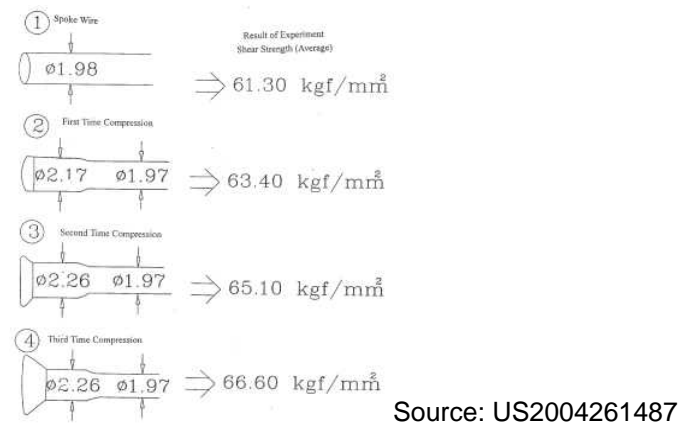

References

Informative references

Attention is drawn to the following places, which may be of interest for search:

Methods for forging, hammering or pressing to perform upsetting	B21J 5/08
---	---------------------------

B21F 7/00

Twisting wire; Twisting wire together (for connections of limited size B21F 15/04)

Definition statement

This place covers:

Methods and devices for continuously twisting of wire, i.e. twisting of a wire of theoretically unlimited length.

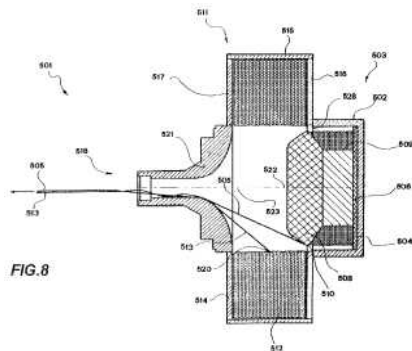

Source: EP1693126

References

Limiting references

This place does not cover:

Connecting wire with wire without additional connecting element or material, e.g. by twisting	B21J 15/04
Electrically-conductive connections between two or more conductive members in direct contact effected by twisting wire	H01R 4/12

Informative references

Attention is drawn to the following places, which may be of interest for search:

Jacketing or reinforcing articles with wires	B21F 17/00
Wire working in the manufacture of flexible shafts or hollow conduits, e.g. for Bowden mechanisms	B21F 45/06
Producing bead-rings or bead-cores	B29D 30/48
Methods or apparatus specially adapted for manufacturing, assembling, maintaining or repairing dynamo-electric machines	H02K 15/0025

B21F 9/00

Straining wire (straining prestressing wires for concrete [E04G 21/12](#); connections or attachments adapted for straining [F16G 11/00](#); {bundling machines or tools [B65B 13/00](#)})

Definition statement

This place covers:

Methods and devices for straining wires, i.e. tensioning wires with or without plastic deformation.

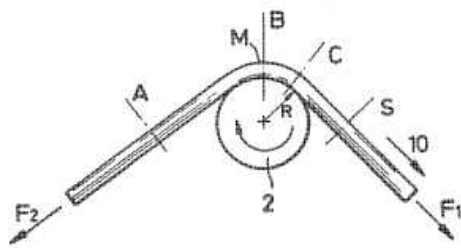

Source: WO9429046

References

Limiting references

This place does not cover:

Connections or attachments adapted for straining of cables, ropes or wire	F16G 11/12
---	----------------------------

Informative references

Attention is drawn to the following places, which may be of interest for search:

Straightening wire	B21F 1/02
Bundling machines or tools	B65B 13/00
Hand tools for cable tie applications	B65B 13/027
Pre-stressing building material	E04G 21/12

B21F 11/00**Cutting wire (hand cutting tools [B26B](#))****Definition statement**

This place covers:

Methods and devices for cutting wire

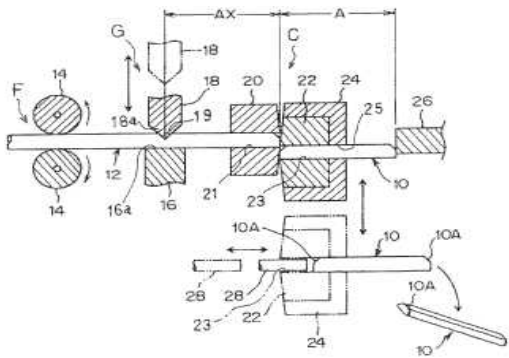

Source: US6427433

References**Limiting references**

This place does not cover:

Cutting wire nets	B21F 33/005
Hand operated metal-shearing devices for cutting wires	B23D 29/023

Informative references

Attention is drawn to the following places, which may be of interest for search:

Machines or devices for shearing or cutting profiled stock	B23D 23/00
Hand-held cutting tools not otherwise provided for	B26B
Hand cutting tools using wires as cutting means	B26B 27/002
Cutting	B26D

B21F 13/00

Splitting wire

Definition statement

This place covers:

Methods and devices for splitting, i.e. separating wire portions lengthwise.

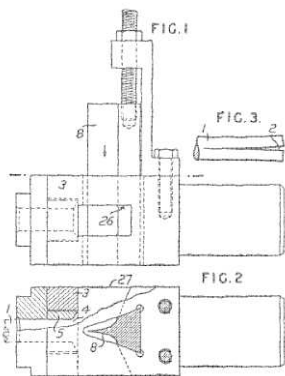

Source: GB786261

B21F 15/00

Connecting wire to wire or other metallic material or objects; Connecting parts by means of wire (tools for both straining and connecting [B21F 9/00](#); jacketing or reinforcing [B21F 17/00](#); manufacture of wire network [B21F 27/00](#); in making bands [B21F 43/00](#) {; bundling machines or tools [B65B 13/00](#); for semiconductors [H01L 24/85](#)})

Definition statement

This place covers:

Methods and devices for connecting wire to wire or other metallic material; connecting parts by means of wire.

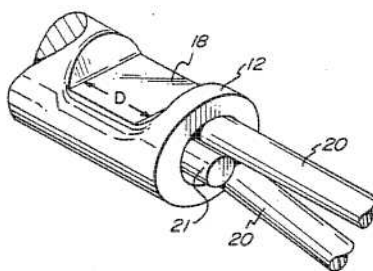

Source: US5224955

References

Limiting references

This place does not cover:

Straining wire by tools also adapted for making connections	B21F 9/02
Making wire networks with additional connecting elements or material at crossings	B21F 27/08
Making wire networks with welded or soldered crossings	B21F 27/10

Applying and securing binding material around articles using strings, wires, strips, bands, tapes	B65B 13/02
Attaching or detaching leads of semi-conductors	H01L 24/80

Informative references

Attention is drawn to the following places, which may be of interest for search:

Jacketing or reinforcing articles with wire	B21F 17/00
Making bands, e.g. bracelets of wire	B21F 43/00
Soldering or unsoldering; Welding	B23K

B21F 17/00

Jacketing or reinforcing articles with wire (by winding [B65H 54/00](#), [B65H 81/00](#); by braiding [D04C](#))

Definition statement

This place covers:

Methods and devices for jacketing articles with wire, i.e. winding one or more wire around an article (which article can be a wire); reinforcing articles with wire (e.g. reinforcing paper with wire).

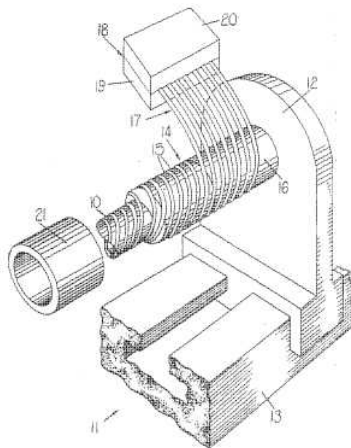

Source: GB1324072

References

Limiting references

This place does not cover:

Jacketing or reinforcing of articles with wires by winding or coiling	B65H 54/00 , B65H 81/00
Making alloys containing metallic or non-metallic fibres or filaments by forming the fibres or filaments into a preformed structure from wires or filaments only	C22C 47/062
Jacketing or reinforcing of articles with wires by braiding	D04C

B21F 19/00

Metallic coating of wire (by extruding [B21C 23/24](#); by soldering or welding, e.g. cladding or plating [B23K](#); by other non-mechanical means [C23](#); electroplating [C25D](#))

Definition statement

This place covers:

Methods and devices for coating metal wires, e.g. by using a metal band.

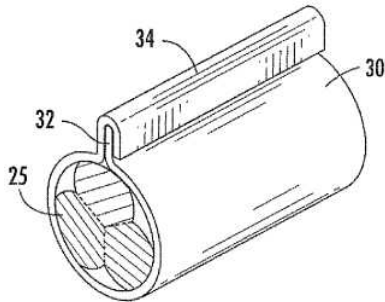

Source: US2009311553

References

Limiting references

This place does not cover:

Coating of wire by extrusion	B21C 23/14
Coating of wire by soldering or welding, e.g. cladding or plating	B23K
Coating of wire by other non-mechanical means	C23
Coating of wire by electroplating	C25D

B21F 23/00

Feeding wire in wire-working machines or apparatus (applicable also to feeding rods or strips [B21D 43/00](#))

Definition statement

This place covers:

Methods and devices for feeding wire.

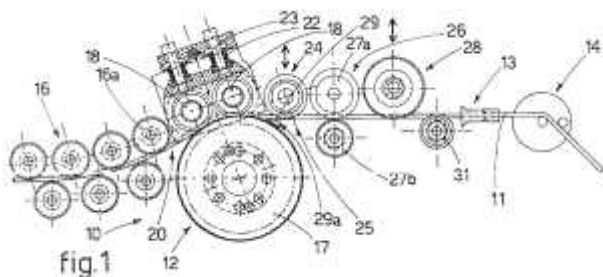

Source: EP0824982

References

Limiting references

This place does not cover:

Guiding wire	B21F 99/00
Feeding wire in wire-working machines, said machines also being applicable to feed rods or strips	B21D 43/00

Informative references

Attention is drawn to the following places, which may be of interest for search:

Arrangements for moving, supporting or positioning work specially adapted for metal rolling mills	B21B 39/006
Forwarding filamentary material	B65H 51/00

B21F 25/00

Making barbed wire

Definition statement

This place covers:

Methods and devices for making barbed wires or barbed tapes.

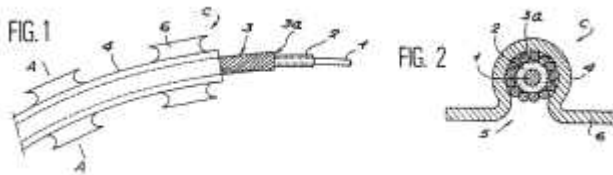

Source: GB2300206

References

Informative references

Attention is drawn to the following places, which may be of interest for search:

Barbed wires	F41H 11/08
--------------	----------------------------

B21F 27/00

Making wire network, i.e. wire nets (meshed-ring network [B21F 31/00](#); in making bands [B21F 43/00](#); using looms [D03D](#))

Definition statement

This place covers:

Methods and devices for making wire networks, e.g. fences or reinforcements for concrete.

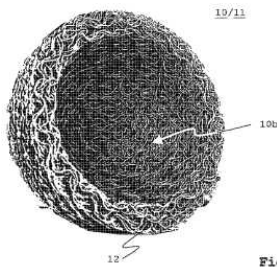

Fig. 4.c Source: EP2153800

References

Limiting references

This place does not cover:

Making fencing or the like partly of wire	B21F 29/00
Making meshed ring network from wire	B21F 31/00
Making bands from wire	B21F 43/00
Making other particular articles from wire	B21F 45/00
Making wire network using looms	D03D

Informative references

Attention is drawn to the following places, which may be of interest for search:

Connecting wire to wire or other metallic material	B21F 15/00
Bending wire networks	B21D 11/125
Soldering or unsoldering; Welding	B23K
Reinforcing elements, e.g. for concrete	E04C 5/00
Fencing	E04H 17/00

B21F 29/00

Making fencing or like material made partly of wire ([B21F 25/00](#), [B21F 27/00](#) take precedence)

Definition statement

This place covers:

Methods and devices for making structures partly of wire and partly of other elements, e.g. fences reinforced with bars.

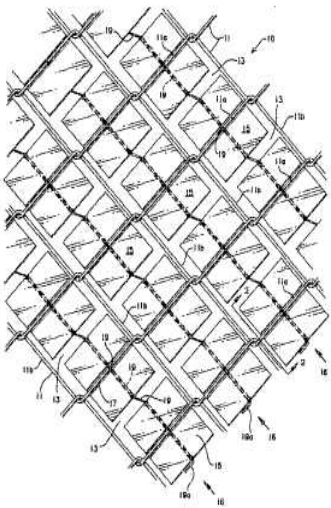

Source: US4651975

B21F 31/00

Making meshed-ring network from wire

Definition statement

This place covers:

Methods and devices for making networks, e.g. fences, obtained by interlacing rings of metal wires, e.g. fences for securing rocks.

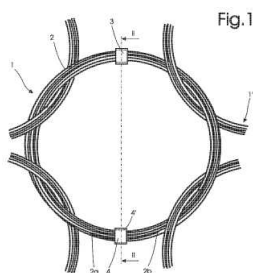

Source: EP1662047

Special rules of classification

Interlaced rings can be of non-circular shape.

B21F 33/00

Tools or devices specially designed for handling or processing wire fabrics or the like

Definition statement

This place covers:

Methods and devices for handling or processing wire fabrics, i.e. further handling or processing of products manufactured from wire (e.g. connecting wire products, coiling wire products, etc).

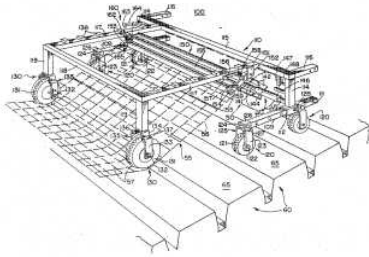

Source: US3814144

References

Informative references

Attention is drawn to the following places, which may be of interest for search:

Bending of wire networks	B21D 11/125
Upholstery	B68

B21F 35/00

Making springs from wire (by coiling wire [B21F 3/00](#); making resilient rings [B21F 37/02](#))

Definition statement

This place covers:

Methods and devices for making springs from wire.

Miscellaneous spring manufacturing processes, not necessarily starting from wire, not otherwise provided for.

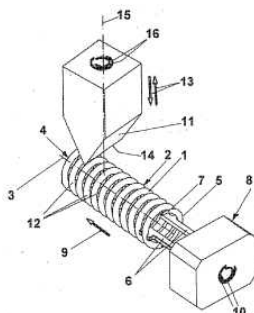

Fig. 1 Source: EP1533053

References

Informative references

Attention is drawn to the following places, which may be of interest for search:

Bending wire other than coiling	B21F 3/00
Manufacture of resilient rings	B21F 37/02
Springs	F16F 1/00

B21F 37/00

Manufacture of rings from wire (in chain making [B21L](#); making of tyre beads [B29D 30/48](#))

Definition statement

This place covers:

Methods and devices for the manufacture of rings from wire.

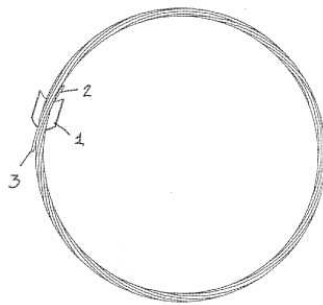

FIG. 1 Source: EP1504828

References

Limiting references

This place does not cover:

Manufacture of rings in chain making	B21L
Manufacture of rings in tyre beads making	B29D 30/48

B21F 39/00**Making wheel spokes from wire****Definition statement**

This place covers:

Methods and devices for the manufacture of wheel spokes from wire.

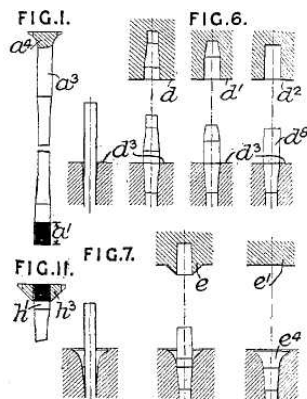

Source: GB357081

B21F 41/00**Making umbrella frames or members from wire****Definition statement**

This place covers:

Methods and devices for the manufacture of umbrella frames or members from wire.

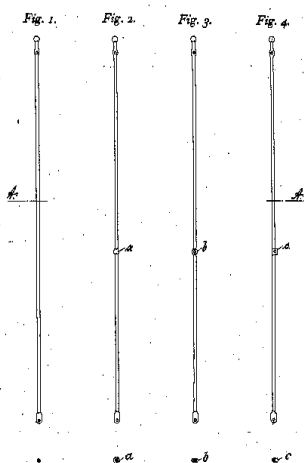

Source: DE177303

B21F 43/00

Making bands, e.g. bracelets, or wire (making chains [B21L](#); using looms [D03D](#))

Definition statement

This place covers:

Methods and devices for the manufacture of bands or bracelets from wire.

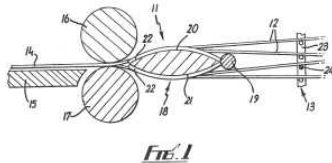

Source: GB2079336

References

Limiting references

This place does not cover:

Making bands using looms	D03D
--------------------------	----------------------

Informative references

Attention is drawn to the following places, which may be of interest for search:

Bracelets	A44C 5/00
Making chains	B21L

B21F 45/00

Wire-working in the manufacture of other particular articles (of pins, needles, nails, hairpins [B21G](#); of chains [B21L](#){; for semiconductor devices [H01L 24/42](#)})

Definition statement

This place covers:

Methods and devices for the manufacture of all wire products if neither classifiable in a sub-group of [B21F 45/00](#) nor in a class ranging from [B21F 25/00](#)-[B21F 43/00](#) nor in a specific product class.

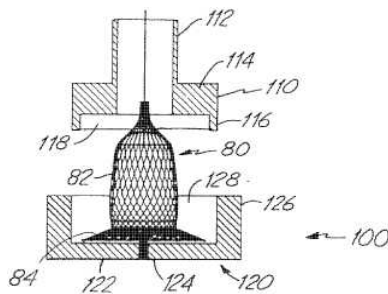

Source: US2002198561

References**Limiting references**

This place does not cover:

Wire working in the manufacture of pins, needles, mails, hairpins	B21G
Wire working in the manufacture of chains	B21L
Wire working for semi-conductor devices	H01L 24/42

B21F 99/00

Subject matter not provided for in other groups of this subclass

Definition statement

This place covers:

Subject-matter not provided for in other groups of this subclass concerning the working and processing of wire, such as e.g. heat treatments specifically adapted for wires.