

EUROPEAN PATENT OFFICE
U.S. PATENT AND TRADEMARK OFFICE

CPC NOTICE OF CHANGES 808

DATE: FEBRUARY 1, 2020

PROJECT RP0608

The following classification changes will be effected by this Notice of Changes:

<u>Action</u>	<u>Subclass</u>	<u>Group(s)</u>
SCHEME:		
Symbols Deleted:	D06F	33/02
	D06F	39/002, 39/003, 39/004, 39/005
	D06F	58/28, 2058/2803, 2058/2806, 2058/2809, 2058/2812, 2058/2816, 2058/2819, 2058/2822, 2058/2825, 2058/2829, 2058/2832, 2058/2835, 2058/2838, 2058/2841, 2058/2845, 2058/2848, 2058/2851, 2058/2854, 2058/2858, 2058/2861, 2058/2864, 2058/2867, 2058/287, 2058/2874, 2058/2877, 2058/288, 2058/2883, 2058/2887, 2058/289, 2058/2893, 2058/2896
	D06F	2232/00, 2232/02, 2232/04, 2232/06, 2232/08, 2232/10
	D06F	2700/00, 2700/04, 2700/05, 2700/052, 2700/055, 2700/057
Symbols Deleted Pending Reclassification: (frozen (F))	D06F	37/203, 37/306
	D06F	39/045
	D06F	2202/00, 2202/02, 2202/04, 2202/06, 2202/065, 2202/08, 2202/085, 2202/10, 2202/12
	D06F	2204/00, 2204/02, 2204/04, 2204/06, 2204/065, 2204/08, 2204/082, 2204/084, 2204/086, 2204/088, 2204/10
	D06F	2210/00
	D06F	2212/00, 2212/02, 2212/04, 2212/06
	D06F	2214/00
	D06F	2216/00
	D06F	2220/00
	D06F	2222/00
	D06F	2224/00
	D06F	2226/00
Symbols New:	D06F	33/30, 33/32, 33/34, 33/36, 33/37, 33/38, 33/40, 33/42, 33/43, 33/44, 33/46, 33/47, 33/48, 33/50, 33/52, 33/54, 33/56, 33/57, 33/58, 33/60, 33/62, 33/63, 33/64, 33/65, 33/68, 33/69, 33/70, 33/72, 33/74, 33/76
	D06F	34/00, 34/04, 34/05, 34/06, 34/08, 34/10, 34/14, 34/16, 34/18, 34/20, 34/22, 34/24, 34/26, 34/28, 34/30, 34/32, 34/34

CPC NOTICE OF CHANGES 808

DATE: FEBRUARY 1, 2020

PROJECT RP0608

<u>Action</u>	<u>Subclass</u>	<u>Group(s)</u>
	D06F	58/30, 58/32, 58/34, 58/36, 58/38, 58/40, 58/42, 58/44, 58/45, 58/46, 58/48, 58/50, 58/52
	D06F	2101/00, 2101/02, 2101/04, 2101/06, 2101/10, 2101/12, 2101/14, 2101/16, 2101/18, 2101/20
	D06F	2103/00, 2103/02, 2103/04, 2103/06, 2103/08, 2103/10, 2103/12, 2103/14, 2103/16, 2103/18, 2103/20, 2103/22, 2103/24, 2103/26, 2103/28, 2103/30, 2103/32, 2103/34, 2103/36, 2103/38, 2103/40, 2103/42, 2103/44, 2103/46, 2103/48, 2103/50, 2103/52, 2103/54, 2103/56, 2103/58, 2103/60, 2103/62, 2103/64, 2103/66, 2103/68, 2103/70
	D06F	2105/00, 2105/02, 2105/04, 2105/06, 2105/08, 2105/10, 2105/12, 2105/14, 2105/16, 2105/18, 2105/20, 2105/22, 2105/24, 2105/26, 2105/28, 2105/30, 2105/32, 2105/34, 2105/36, 2105/38, 2105/40, 2105/42, 2105/44, 2105/46, 2105/48, 2105/50, 2105/52, 2105/54, 2105/56, 2105/58, 2105/60, 2105/62
Titles Changed:	D06F	subclass
	D06F	1/04
	D06F	5/00
	D06F	13/00
	D06F	17/00
	D06F	18/00
	D06F	19/00
	D06F	21/00
	D06F	23/00
	D06F	25/00
	D06F	33/00
	D06F	37/00, 37/20, 37/30, 37/304
	D06F	39/00, 39/007, 39/08, 39/085
	D06F	43/08
	D06F	45/14
	D06F	49/00, 49/06
	D06F	53/00, 53/04
	D06F	57/00
	D06F	58/00, 58/02, 58/04, 58/20
	D06F	59/00
	D06F	67/00, 67/02, 67/08
	D06F	71/00, 71/08, 71/18, 71/30
	D06F	73/00
	D06F	75/24, 75/26
	D06F	79/04
	D06F	81/00
	D06F	87/00

CPC NOTICE OF CHANGES 808

DATE: FEBRUARY 1, 2020

PROJECT RP0608

<u>Action</u>	<u>Subclass</u>	<u>Group(s)</u>
	D06F	95/00
Warnings New:	D06F	18/00
	D06F	19/00
	D06F	25/00
	D06F	31/00
	D06F	33/00, 33/04, 33/30, 33/32, 33/34, 33/36, 33/37, 33/38, 33/40, 33/42, 33/43, 33/44, 33/46, 33/47, 33/48, 33/50, 33/57, 33/58, 33/60, 33/62, 33/63, 33/65, 33/68, 33/69, 33/70, 33/72, 33/74, 33/76
	D06F	34/00, 34/04, 34/06, 34/08, 34/10, 34/14, 34/16, 34/18, 34/20, 34/22, 34/24, 34/26, 34/28, 34/30
	D06F	35/00, 35/001, 35/002, 35/003, 35/004, 35/005, 35/006, 35/007, 35/008
	D06F	37/00, 37/10, 37/18, 37/203, 37/22, 37/225, 37/24, 37/245, 37/28, 37/30, 37/302, 37/304, 37/306, 37/42
	D06F	39/00, 39/006, 39/007, 39/008, 39/02, 39/022, 39/024, 39/026, 39/028, 39/04, 39/045, 39/06, 39/08, 39/081, 39/082, 39/083, 39/085, 39/086, 39/087, 39/088, 39/10, 39/12, 39/125, 39/14
	D06F	58/00, 58/02, 58/04, 58/08, 58/10, 58/12, 58/14, 58/20, 58/203, 58/206, 58/22, 58/24, 58/26, 58/263, 58/266, 58/30, 58/32, 58/34, 58/38, 58/40, 58/45, 58/46, 58/48, 58/50, 58/52
	D06F	2101/00, 2101/02
	D06F	2103/00, 2103/02, 2103/10, 2103/14, 2103/16, 2103/18, 2103/20, 2103/22, D06F 2103/24, D06F 2103/26, D06F 2103/28, 2103/38, 2103/40, 2103/42, 2103/44, 2103/46, 2103/48, 2103/50, 2103/52, 2103/54, 2103/58, 2103/60, 2103/62, 2103/64, 2103/66, 2103/68
	D06F	2105/00, 2105/02, 2105/04, 2105/06, 2105/08, 2105/10, 2105/12, 2105/14, 2105/26, 2105/28, 2105/30, 2105/34, 2105/36, 2105/38, 2105/40, 2105/42, 2105/44, 2105/46, 2105/48, 2105/50, 2105/52, 2105/54, 2105/56, 2105/58, 2105/60, 2105/62
	D06F	2202/00, 2202/02, 2202/04, 2202/06, 2202/065, 2202/08, 2202/085, 2202/10, 2202/12

CPC NOTICE OF CHANGES 808

DATE: FEBRUARY 1, 2020

PROJECT RP0608

<u>Action</u>	<u>Subclass</u>	<u>Group(s)</u>
	D06F	2204/00, 2204/02, 2204/04, 2204/06, 2204/065, 2204/08, 2204/082, 2204/084, 2204/086, 2204/088, 2204/10
	D06F	2210/00
	D06F	2212/00, 2212/02, 2212/04, 2212/06
	D06F	2214/00
	D06F	2216/00
	D06F	2220/00
	D06F	2222/00
	D06F	2224/00
	D06F	2226/00
Notes Deleted:	D06F	2058/2896
Notes New:	D06F	33/00
	D06F	34/00
	D06F	58/00
Notes Modified:	D06F	subclass
Guidance Headings New:	D06F	2101/00 -2105/62
Guidance Headings Modified:	D06F	61/00-85/00
	D06F	87/00 – 95/008
DEFINITIONS:		
Definitions Deleted:	D06F	33/02
	D06F	39/002, 39/003, 39/004, 39/005
	D06F	58/28
Definitions New:	D06F	33/30, 33/32, 33/34, 33/36, 33/37, 33/38, 33/40, 33/42, 33/43, 33/44, 33/46, 33/47, 33/48, 33/50, 33/52, 33/54, 33/56, 33/57, 33/58, 33/60, 33/62, 33/63, 33/64, 33/65, 33/68, 33/69, 33/70, 33/72, 33/74, 33/76
	D06F	34/00, 34/04, 34/05, 34/06, 34/08, 34/10, 34/14, 34/16, 34/18, 34/20, 34/22, 34/24, 34/26, 34/28, 34/30, 34/32, 34/34
	D06F	58/30, 58/32, 58/34, 58/36, 58/38, 58/40, 58/42, 58/44, 58/45, 58/46, 58/48, 58/50, 58/52
Definitions Modified:	D06F	subclass
	D06F	5/00
	D06F	13/00
	D06F	15/00
	D06F	17/00, 17/02
	D06F	18/00
	D06F	19/00

CPC NOTICE OF CHANGES 808

DATE: FEBRUARY 1, 2020

PROJECT RP0608

<u>Action</u>	<u>Subclass</u>	<u>Group(s)</u>
	D06F	21/00
	D06F	23/00
	D06F	25/00
	D06F	29/02
	D06F	33/02
	D06F	37/00, 37/20, 37/203, 37/30
	D06F	39/00, 39/08, 39/087, 39/12, 39/14
	D06F	43/00, 43/08
	D06F	45/14
	D06F	49/00, 49/06
	D06F	53/00, 53/04
	D06F	57/00, 57/02
	D06F	58/00, 58/04, 58/10, 58/16, 58/20, 58/26
	D06F	59/00
	D06F	67/00
	D06F	71/00, 71/02, 71/04, 71/16, 71/30, 71/36, 71/38
	D06F	73/00
	D06F	75/06, 75/10, 75/22, 75/24, 75/26, 75/38
	D06F	79/04
	D06F	81/00
	D06F	87/00
	D06F	95/00

The following subclasses/groups are also impacted by this Notice of Changes: A47L, G01G

This Notice of Changes includes the following [Check the ones included]:

1. CLASSIFICATION SCHEME CHANGES

- A. New, Modified or Deleted Group(s)
- B. New, Modified or Deleted Warning(s)
- C. New, Modified or Deleted Note(s)
- D. New, Modified or Deleted Guidance Heading(s)

2. DEFINITIONS

- A. New or Modified Definitions (Full definition template)
- B. Modified or Deleted Definitions (Definitions Quick Fix)

- 3. REVISION CONCORDANCE LIST (RCL)
- 4. CHANGES TO THE CPC-TO-IPC CONCORDANCE LIST (CICL)
- 5. CHANGES TO THE CROSS-REFERENCE LIST (CRL)

CPC NOTICE OF CHANGES 808

DATE: FEBRUARY 1, 2020

PROJECT RP0608

1. CLASSIFICATION SCHEME CHANGES

A. New, Modified or Deleted Group(s)

SUBCLASS D06F - LAUNDERING, DRYING, IRONING, PRESSING OR FOLDING TEXTILE ARTICLES (apparatus for blocking, pressing, steaming, or stretching hats A42C; treating textile materials by liquids, gases or vapours D06B; chemical matters, see D06L, D06M)

<u>Type*</u>	<u>Symbol</u>	<u>Indent Level Number of dots (e.g. 0, 1, 2)</u>	<u>Title</u> <u>“CPC only” text should normally be enclosed in {curly brackets}**</u>	<u>Transferred to#</u>
M	D06F	Subclass	LAUNDERING, DRYING, IRONING, PRESSING OR FOLDING TEXTILE ARTICLES	
M	D06F 1/04	2	the tub walls or bottom having corrugations	
M	D06F 5/00	0	Hand implements for washing purposes, e.g. sticks (hand rubbing appliances D06F 3/00)	
M	D06F 13/00	0	Washing machines having receptacles, stationary for washing purposes, with agitators therein contacting the articles being washed (plungers or the like adapted for removable mounting on receptacles D06F 5/04)	
M	D06F 17/00	0	Washing machines having receptacles, stationary for washing purposes, wherein the washing action is effected solely by circulation or agitation of the washing liquid	
C	D06F 18/00	0	Washing machines having receptacles, stationary for washing purposes, and having further drying means (control of washing or of washing and drying D06F 33/00, D06F 34/00; domestic laundry dryers D06F 58/00)	D06F 18/00, D06F 31/00, D06F 31/005, D06F 33/00, D06F 33/04, D06F 33/06, D06F 33/08, D06F 33/10, D06F 33/30, D06F 33/32, D06F 33/34, D06F 33/36, D06F 33/37, D06F 33/38, D06F 33/40, D06F 33/42, D06F 33/43, D06F 33/44, D06F 33/46, D06F 33/47, D06F 33/48, D06F 33/50, D06F 33/52, D06F 33/54, D06F 33/56, D06F 33/57, D06F 33/58, D06F 33/60, D06F 33/62, D06F 33/63, D06F 33/64, D06F 33/65,

CPC NOTICE OF CHANGES 808

DATE: FEBRUARY 1, 2020

PROJECT RP0608

<u>Type*</u>	<u>Symbol</u>	<u>Indent Level Number of dots (e.g. 0, 1, 2)</u>	<u>Title</u> <u>“CPC only” text should normally be enclosed in {curly brackets}**</u>	<u>Transferred to#</u>
				D06F 33/68, D06F 33/69, D06F 33/70, D06F 33/72, D06F 33/74, D06F 33/76, D06F 34/00, D06F 34/04, D06F 34/05, D06F 34/06, D06F 34/08, D06F 34/10, D06F 34/14, D06F 34/16, D06F 34/18, D06F 34/20, D06F 34/22, D06F 34/24, D06F 34/26, D06F 34/28, D06F 34/30, D06F 34/32, D06F 34/34, D06F 37/42, D06F 2101/00, D06F 2101/02, D06F 2101/04, D06F 2101/06, D06F 2101/10, D06F 2101/12, D06F 2101/14, D06F 2101/16, D06F 2101/18, D06F 2101/20, D06F 2103/00, D06F 2103/02, D06F 2103/04, D06F 2103/06, D06F 2103/08, D06F 2103/10, D06F 2103/12, D06F 2103/14, D06F 2103/16, D06F 2103/18, D06F 2103/20, D06F 2103/22, D06F 2103/24, D06F 2103/26, D06F 2103/28, D06F 2103/30, D06F 2103/32, D06F 2103/34, D06F 2103/36, D06F 2103/38, D06F 2103/40, D06F 2103/42, D06F 2103/44, D06F 2103/46, D06F 2103/48, D06F 2103/50, D06F 2103/52, D06F 2103/54, D06F 2103/56, D06F 2103/58, D06F 2103/60, D06F 2103/62, D06F 2103/64, D06F 2103/66, D06F 2103/68, D06F 2103/70, D06F 2105/50, D06F 2105/52, D06F 2105/54, D06F 2105/56, D06F 2105/58, D06F 2105/60, D06F 2105/62
C	D06F 19/00	0	Washing machines using vibrations for washing purposes	D06F 19/00, D06F 2103/66
T	D06F 21/00	0	Washing machines with receptacles, e.g. perforated, having a rotary movement, e.g. oscillatory movement (with receptacles serving both for washing and centrifugally	

CPC NOTICE OF CHANGES 808

DATE: FEBRUARY 1, 2020

PROJECT RP0608

<u>Type*</u>	<u>Symbol</u>	<u>Indent Level Number of dots (e.g. 0, 1, 2)</u>	<u>Title</u> <u>“CPC only” text should normally be enclosed in {curly brackets}**</u>	<u>Transferred to#</u>
			separating water from the laundry D06F 23/00, D06F 25/00; programme control aspects D06F 33/00)	
M	D06F 23/00	0	Washing machines with receptacles, e.g. perforated, having a rotary movement, e.g. oscillatory movement, the receptacle serving both for washing and for centrifugally separating water from the laundry (with further drying means D06F 25/00; programme control aspects D06F 33/00)	
C	D06F 25/00	0	Washing machines with receptacles, e.g. perforated, having a rotary movement, e.g. oscillatory movement, the receptacle serving both for washing and for centrifugally separating water from the laundry and having further drying means, e.g. using hot air (control of washing or of washing and drying D06F 33/00, D06F 34/00; domestic laundry dryers D06F 58/00)	D06F 25/00, D06F 34/00, D06F 34/04, D06F 34/05, D06F 34/06, D06F 34/08, D06F 34/10, D06F 34/14, D06F 34/16, D06F 34/18, D06F 34/20, D06F 34/22, D06F 34/24, D06F 34/26, D06F 34/28, D06F 34/30, D06F 34/32, D06F 34/34, D06F 37/42, D06F 2101/00, D06F 2101/02, D06F 2101/04, D06F 2101/06, D06F 2101/10, D06F 2101/12, D06F 2101/14, D06F 2101/16, D06F 2101/18, D06F 2101/20, D06F 2103/00, D06F 2103/02, D06F 2103/04, D06F 2103/06, D06F 2103/08, D06F 2103/20, D06F 2103/22, D06F 2103/68, D06F 2103/70, D06F 2105/50, D06F 2105/52, D06F 2105/54, D06F 2105/56, D06F 2105/58, D06F 2105/60, D06F 2105/62
C	D06F 33/00	0	Control of operations performed in washing machines or washer-dryers (D06F 31/00 takes precedence; details of control systems therefor D06F 34/00; control of operations performed in domestic laundry dryers D06F 58/32)	D06F 33/00, D06F 33/30, D06F 33/32, D06F 33/34, D06F 33/36, D06F 33/37, D06F 33/38, D06F 33/40, D06F 33/42, D06F 33/43, D06F 33/44, D06F 33/46, D06F 33/47, D06F 33/48, D06F 33/50, D06F 33/52, D06F 33/54, D06F 33/56, D06F 33/57, D06F 33/58, D06F 33/60, D06F 33/62,

CPC NOTICE OF CHANGES 808

DATE: FEBRUARY 1, 2020

PROJECT RP0608

<u>Type*</u>	<u>Symbol</u>	<u>Indent Level Number of dots (e.g. 0, 1, 2)</u>	<u>Title</u> <u>“CPC only” text should normally be enclosed in {curly brackets}**</u>	<u>Transferred to#</u>
				D06F 33/63, D06F 33/64, D06F 33/65, D06F 33/68, D06F 33/69, D06F 33/70, D06F 33/72, D06F 33/74, D06F 33/76, D06F 34/00, D06F 34/04, D06F 34/05, D06F 34/06, D06F 34/08, D06F 34/10, D06F 34/14, D06F 34/16, D06F 34/18, D06F 34/20, D06F 34/22, D06F 34/24, D06F 34/26, D06F 34/28, D06F 34/30, D06F 34/32, D06F 34/34, D06F 37/42, D06F 58/32, D06F 58/34, D06F 58/36, D06F 58/38, D06F 58/40, D06F 58/42, D06F 58/44, D06F 58/45, D06F 58/46, D06F 58/48, D06F 58/50, D06F 58/52, D06F 2101/00, D06F 2101/02, D06F 2101/04, D06F 2101/06, D06F 2101/10, D06F 2101/12, D06F 2101/14, D06F 2101/16, D06F 2101/18, D06F 2101/20, D06F 2103/00, D06F 2103/02, D06F 2103/04, D06F 2103/06, D06F 2103/08, D06F 2103/10, D06F 2103/12, D06F 2103/14, D06F 2103/16, D06F 2103/18, D06F 2103/20, D06F 2103/22, D06F 2103/24, D06F 2103/26, D06F 2103/28, D06F 2103/30, D06F 2103/32, D06F 2103/34, D06F 2103/36, D06F 2103/38, D06F 2103/40, D06F 2103/42, D06F 2103/44, D06F 2103/46, D06F 2103/48, D06F 2103/50, D06F 2103/52, D06F 2103/54, D06F 2103/56, D06F 2103/58, D06F 2103/60, D06F 2103/62, D06F 2103/64, D06F 2103/66, D06F 2103/68, D06F 2103/70, D06F 2105/00, D06F 2105/02, D06F 2105/04, D06F 2105/06, D06F 2105/08, D06F 2105/10, D06F 2105/12,

CPC NOTICE OF CHANGES 808

DATE: FEBRUARY 1, 2020

PROJECT RP0608

<u>Type*</u>	<u>Symbol</u>	<u>Indent Level Number of dots (e.g. 0, 1, 2)</u>	<u>Title</u> <u>“CPC only” text should normally be enclosed in {curly brackets}**</u>	<u>Transferred to#</u>
				D06F 2105/14, D06F 2105/16, D06F 2105/18, D06F 2105/20, D06F 2105/22, D06F 2105/24, D06F 2105/26, D06F 2105/28, D06F 2105/30, D06F 2105/32, D06F 2105/34, D06F 2105/36, D06F 2105/38, D06F 2105/40, D06F 2105/42, D06F 2105/44, D06F 2105/46, D06F 2105/48, D06F 2105/50, D06F 2105/52, D06F 2105/54, D06F 2105/56, D06F 2105/58, D06F 2105/60, D06F 2105/62
D	D06F 33/02	1	electrically	<Administrative transfer to D06F33/00>
U	D06F 33/10	2	substantially pneumatically	
N	D06F 33/30	1	Control of washing machines characterised by the purpose or target of the control (controlling processes of washer-dryers D06F 33/50)	
N	D06F 33/32	2	Control of operational steps, e.g. optimisation or improvement of operational steps depending on the condition of the laundry	
N	D06F 33/34	3	of water filling	
N	D06F 33/36	3	of washing	
N	D06F 33/37	3	of metering of detergents or additives	
N	D06F 33/38	3	of rinsing	
N	D06F 33/40	3	of centrifugal separation of water from the laundry	
N	D06F 33/42	3	of draining	
N	D06F 33/43	2	Control of cleaning or disinfection of washing machine parts, e.g. of tubs	
N	D06F 33/44	2	Control of the operating time, e.g. reduction of overall operating time	
N	D06F 33/46	2	Control of the energy or water consumption	
N	D06F 33/47	2	Responding to irregular working conditions, e.g. malfunctioning of pumps (safety arrangements D06F 37/42)	
N	D06F 33/48	2	Preventing or reducing imbalance or noise	

CPC NOTICE OF CHANGES 808

DATE: FEBRUARY 1, 2020

PROJECT RP0608

<u>Type*</u>	<u>Symbol</u>	<u>Indent Level Number of dots (e.g. 0, 1, 2)</u>	<u>Title</u> <u>“CPC only” text should normally be enclosed in {curly brackets}**</u>	<u>Transferred to#</u>
N	D06F 33/50	1	Control of washer-dryers characterised by the purpose or target of the control	
N	D06F 33/52	2	Control of the operational steps, e.g. optimisation or improvement of operational steps depending on the condition of the laundry	
N	D06F 33/54	3	of water filling	
N	D06F 33/56	3	of washing	
N	D06F 33/57	3	of metering of detergents or additives	
N	D06F 33/58	3	of rinsing	
N	D06F 33/60	3	of centrifugal separation of water from the laundry	
N	D06F 33/62	3	of draining	
N	D06F 33/63	3	of air flow, e.g. blowing air during the washing process to prevent entanglement of the laundry	
N	D06F 33/64	4	Unheated air	
N	D06F 33/65	3	of conditioning or finishing phases, e.g. for smoothing or removing creases	
N	D06F 33/68	3	of the sequence of washing and drying operations	
N	D06F 33/69	2	Control of cleaning or disinfection of washer-dryer parts, e.g. of tubs	
N	D06F 33/70	2	Control of the operating time, e.g. reduction of overall operating time	
N	D06F 33/72	2	Control of the energy or water consumption	
N	D06F 33/74	2	Responding to irregular working conditions, e.g. malfunctioning of pumps (safety arrangements for washing machines D06F 37/42)	
N	D06F 33/76	2	Preventing or reducing imbalance or noise	
N	D06F 34/00	0	Details of control systems for washing machines, washer-dryers or laundry dryers	
N	D06F 34/04	1	Signal transfer or data transmission arrangements	
N	D06F 34/05	2	for wireless communication between components, e.g. for remote monitoring or control	
N	D06F 34/06	1	Timing arrangements	

CPC NOTICE OF CHANGES 808

DATE: FEBRUARY 1, 2020

PROJECT RP0608

<u>Type*</u>	<u>Symbol</u>	<u>Indent Level Number of dots (e.g. 0, 1, 2)</u>	<u>Title</u> <u>“CPC only” text should normally be enclosed in {curly brackets}**</u>	<u>Transferred to#</u>
N	D06F 34/08	1	Control circuits or arrangements thereof	
N	D06F 34/10	1	Power supply arrangements, e.g. stand-by circuits	
N	D06F 34/14	1	Arrangements for detecting or measuring specific parameters	
N	D06F 34/16	2	Imbalance	
Q	D06F 34/18	2	Condition of the laundry, e.g. nature or weight	D06F 34/18, D06F 2103/02, D06F 2103/04, D06F 2103/06, D06F 2103/08
N	D06F 34/20	2	Parameters relating to constructional components, e.g. door sensors	
Q	D06F 34/22	2	Condition of the washing liquid, e.g. turbidity	D06F 34/22, D06F 2103/20, D06F 2103/22
N	D06F 34/24	3	Liquid temperature	
N	D06F 34/26	2	Condition of the drying air, e.g. air humidity or temperature	
Q	D06F 34/28	1	Arrangements for program selection, e.g. control panels therefor; Arrangements for indicating program parameters, e.g. the selected program or its progress	D06F 34/28, D06F 34/30, D06F 34/32, D06F 34/34, D06F 2101/00, D06F 2101/02, D06F 2101/04, D06F 2101/06, D06F 2101/10, D06F 2101/12, D06F 2101/14, D06F 2101/16, D06F 2101/18, D06F 2101/20, D06F 2103/68, D06F 2103/70, D06F 2105/50, D06F 2105/52, D06F 2105/54, D06F 2105/56, D06F 2105/58, D06F 2105/60, D06F 2105/62
N	D06F 34/30	2	characterised by mechanical features, e.g. buttons or rotary dials	
N	D06F 34/32	2	characterised by graphical features, e.g. touchscreens	
N	D06F 34/34	2	characterised by mounting or attachment features, e.g. detachable control panels or detachable display panels	
C	D06F 35/00	0	Washing machines, apparatus, or methods not otherwise provided for	D06F 35/00, D06F 34/00, D06F 34/04, D06F 34/05, D06F 34/06, D06F 34/08, D06F 34/10, D06F 34/14, D06F 34/16, D06F 34/18, D06F 34/20, D06F 34/22, D06F 34/24, D06F 34/26, D06F 34/28, D06F 34/30,

CPC NOTICE OF CHANGES 808

DATE: FEBRUARY 1, 2020

PROJECT RP0608

<u>Type*</u>	<u>Symbol</u>	<u>Indent Level Number of dots (e.g. 0, 1, 2)</u>	<u>Title</u> <u>“CPC only” text should normally be enclosed in {curly brackets}**</u>	<u>Transferred to#</u>
				D06F 34/32, D06F 34/34, D06F 2101/00, D06F 2101/02, D06F 2101/04, D06F 2101/06, D06F 2101/10, D06F 2101/12, D06F 2101/14, D06F 2101/16, D06F 2101/18, D06F 2101/20, D06F 2103/02, D06F 2103/04, D06F 2103/06, D06F 2103/08, D06F 2103/20, D06F 2103/22, D06F 2103/66, D06F 2103/68, D06F 2103/70, D06F 2105/50, D06F 2105/52, D06F 2105/54, D06F 2105/56, D06F 2105/58, D06F 2105/60, D06F 2105/62
C	D06F 35/001	1	{using ozone}	D06F 35/001, D06F 34/00, D06F 34/04, D06F 34/05, D06F 34/06, D06F 34/08, D06F 34/10, D06F 34/14, D06F 34/16, D06F 34/18, D06F 34/20, D06F 34/22, D06F 34/24, D06F 34/26, D06F 34/28, D06F 34/30, D06F 34/32, D06F 34/34, D06F 2101/00, D06F 2101/02, D06F 2101/04, D06F 2101/06, D06F 2101/10, D06F 2101/12, D06F 2101/14, D06F 2101/16, D06F 2101/18, D06F 2101/20, D06F 2103/02, D06F 2103/04, D06F 2103/06, D06F 2103/08, D06F 2103/20, D06F 2103/22, D06F 2103/66, D06F 2103/68, D06F 2103/70, D06F 2105/50, D06F 2105/52, D06F 2105/54, D06F 2105/56, D06F 2105/58, D06F 2105/60, D06F 2105/62
C	D06F 35/002	1	{using bubbles}	D06F 35/002, D06F 34/00, D06F 34/04, D06F 34/05, D06F 34/06, D06F 34/08, D06F 34/10, D06F 34/14, D06F 34/16, D06F 34/18, D06F 34/20, D06F 34/22, D06F 34/24, D06F 34/26, D06F 34/28, D06F 34/30, D06F 34/32, D06F 34/34,

CPC NOTICE OF CHANGES 808

DATE: FEBRUARY 1, 2020

PROJECT RP0608

<u>Type*</u>	<u>Symbol</u>	<u>Indent Level Number of dots (e.g. 0, 1, 2)</u>	<u>Title</u> <u>“CPC only” text should normally be enclosed in {curly brackets}**</u>	<u>Transferred to#</u>
				D06F 2101/00, D06F 2101/02, D06F 2101/04, D06F 2101/06, D06F 2101/10, D06F 2101/12, D06F 2101/14, D06F 2101/16, D06F 2101/18, D06F 2101/20, D06F 2103/02, D06F 2103/04, D06F 2103/06, D06F 2103/08, D06F 2103/20, D06F 2103/22, D06F 2103/68, D06F 2103/70, D06F 2105/50, D06F 2105/52, D06F 2105/54, D06F 2105/56, D06F 2105/58, D06F 2105/60, D06F 2105/62
C	D06F 35/003	1	{using electrochemical cells}	D06F 35/003, D06F 34/00, D06F 34/04, D06F 34/05, D06F 34/06, D06F 34/08, D06F 34/10, D06F 34/14, D06F 34/16, D06F 34/18, D06F 34/20, D06F 34/22, D06F 34/24, D06F 34/26, D06F 34/28, D06F 34/30, D06F 34/32, D06F 34/34, D06F 2101/00, D06F 2101/02, D06F 2101/04, D06F 2101/06, D06F 2101/10, D06F 2101/12, D06F 2101/14, D06F 2101/16, D06F 2101/18, D06F 2101/20, D06F 2103/02, D06F 2103/04, D06F 2103/06, D06F 2103/08, D06F 2103/20, D06F 2103/22, D06F 2103/66, D06F 2103/68, D06F 2103/70, D06F 2105/50, D06F 2105/52, D06F 2105/54, D06F 2105/56, D06F 2105/58, D06F 2105/60, D06F 2105/62
C	D06F 35/004	1	{using chlorine generators}	D06F 35/004, D06F 34/00, D06F 34/04, D06F 34/05, D06F 34/06, D06F 34/08, D06F 34/10, D06F 34/14, D06F 34/16, D06F 34/18, D06F 34/20, D06F 34/22, D06F 34/24, D06F 34/26, D06F 34/28, D06F 34/30, D06F 34/32, D06F 34/34, D06F 2101/00, D06F 2101/02, D06F 2101/04, D06F 2101/06,

CPC NOTICE OF CHANGES 808

DATE: FEBRUARY 1, 2020

PROJECT RP0608

<u>Type*</u>	<u>Symbol</u>	<u>Indent Level Number of dots (e.g. 0, 1, 2)</u>	<u>Title</u> <u>“CPC only” text should normally be enclosed in {curly brackets}**</u>	<u>Transferred to#</u>
				D06F 2101/10, D06F 2101/12, D06F 2101/14, D06F 2101/16, D06F 2101/18, D06F 2101/20, D06F 2103/02, D06F 2103/04, D06F 2103/06, D06F 2103/08, D06F 2103/20, D06F 2103/22, D06F 2103/66, D06F 2103/68, D06F 2103/70, D06F 2105/50, D06F 2105/52, D06F 2105/54, D06F 2105/56, D06F 2105/58, D06F 2105/60, D06F 2105/62
C	D06F 35/005	1	{Methods for washing, rinsing or spin-drying}	D06F 35/005, D06F 33/36, D06F 33/38, D06F 33/56, D06F 33/58, D06F 34/00, D06F 34/04, D06F 34/05, D06F 34/06, D06F 34/08, D06F 34/10, D06F 34/14, D06F 34/16, D06F 34/18, D06F 34/20, D06F 34/22, D06F 34/24, D06F 34/26, D06F 34/28, D06F 34/30, D06F 34/32, D06F 34/34, D06F 2101/00, D06F 2101/02, D06F 2101/04, D06F 2101/06, D06F 2101/10, D06F 2101/12, D06F 2101/14, D06F 2101/16, D06F 2101/18, D06F 2101/20, D06F 2103/02, D06F 2103/04, D06F 2103/06, D06F 2103/08, D06F 2103/20, D06F 2103/22, D06F 2103/66, D06F 2103/68, D06F 2103/70, D06F 2105/50, D06F 2105/52, D06F 2105/54, D06F 2105/56, D06F 2105/58, D06F 2105/60, D06F 2105/62
C	D06F 35/006	2	{for washing or rinsing only}	D06F 35/006, D06F 33/36, D06F 33/38, D06F 33/56, D06F 33/58, D06F 34/00, D06F 34/04, D06F 34/05, D06F 34/06, D06F 34/08, D06F 34/10, D06F 34/14, D06F 34/16, D06F 34/18, D06F 34/20, D06F 34/22, D06F 34/24, D06F 34/26, D06F 34/28, D06F 34/30, D06F 34/32, D06F 34/34,

CPC NOTICE OF CHANGES 808

DATE: FEBRUARY 1, 2020

PROJECT RP0608

<u>Type*</u>	<u>Symbol</u>	<u>Indent Level Number of dots (e.g. 0, 1, 2)</u>	<u>Title</u> <u>“CPC only” text should normally be enclosed in {curly brackets}**</u>	<u>Transferred to#</u>
				D06F 2101/00, D06F 2101/02, D06F 2101/04, D06F 2101/06, D06F 2101/10, D06F 2101/12, D06F 2101/14, D06F 2101/16, D06F 2101/18, D06F 2101/20, D06F 2103/02, D06F 2103/04, D06F 2103/06, D06F 2103/08, D06F 2103/20, D06F 2103/22, D06F 2103/68, D06F 2103/70, D06F 2105/50, D06F 2105/52, D06F 2105/54, D06F 2105/56, D06F 2105/58, D06F 2105/60, D06F 2105/62
C	D06F 35/007	2	{for spin-drying only}	D06F 35/007, D06F 33/40, D06F 33/60, D06F 34/00, D06F 34/04, D06F 34/05, D06F 34/06, D06F 34/08, D06F 34/10, D06F 34/14, D06F 34/16, D06F 34/18, D06F 34/20, D06F 34/22, D06F 34/24, D06F 34/26, D06F 34/28, D06F 34/30, D06F 34/32, D06F 34/34, D06F 2101/00, D06F 2101/02, D06F 2101/04, D06F 2101/06, D06F 2101/10, D06F 2101/12, D06F 2101/14, D06F 2101/16, D06F 2101/18, D06F 2101/20, D06F 2103/02, D06F 2103/04, D06F 2103/06, D06F 2103/08, D06F 2103/20, D06F 2103/22, D06F 2103/24, D06F 2103/68, D06F 2103/70, D06F 2105/50, D06F 2105/52, D06F 2105/54, D06F 2105/56, D06F 2105/58, D06F 2105/60, D06F 2105/62
C	D06F 35/008	2	{for disinfecting the tub or the drum}	D06F 35/008, D06F 33/43, D06F 33/69, D06F 34/00, D06F 34/04, D06F 34/05, D06F 34/06, D06F 34/08, D06F 34/10, D06F 34/14, D06F 34/16, D06F 34/18, D06F 34/20, D06F 34/22, D06F 34/24, D06F 34/26, D06F 34/28, D06F 34/30, D06F 34/32, D06F 34/34,

CPC NOTICE OF CHANGES 808

DATE: FEBRUARY 1, 2020

PROJECT RP0608

<u>Type*</u>	<u>Symbol</u>	<u>Indent Level Number of dots (e.g. 0, 1, 2)</u>	<u>Title</u> <u>“CPC only” text should normally be enclosed in {curly brackets}**</u>	<u>Transferred to#</u>
				D06F 2101/00, D06F 2101/02, D06F 2101/04, D06F 2101/06, D06F 2101/10, D06F 2101/12, D06F 2101/14, D06F 2101/16, D06F 2101/18, D06F 2101/20, D06F 2103/02, D06F 2103/04, D06F 2103/06, D06F 2103/08, D06F 2103/20, D06F 2103/22, D06F 2103/68, D06F 2103/70, D06F 2105/50, D06F 2105/52, D06F 2105/54, D06F 2105/56, D06F 2105/58, D06F 2105/60, D06F 2105/62
C	D06F 37/00	0	Details specific to washing machines covered by groups D06F 21/00- D06F 25/00	D06F 37/00, D06F 34/00, D06F 34/04, D06F 34/05, D06F 34/06, D06F 34/08, D06F 34/10, D06F 34/14, D06F 34/16, D06F 34/18, D06F 34/20, D06F 34/22, D06F 34/24, D06F 34/26, D06F 34/28, D06F 34/30, D06F 34/32, D06F 34/34, D06F 2101/00, D06F 2101/02, D06F 2101/04, D06F 2101/06, D06F 2101/10, D06F 2101/12, D06F 2101/14, D06F 2101/16, D06F 2101/18, D06F 2101/20, D06F 2103/02, D06F 2103/04, D06F 2103/06, D06F 2103/08, D06F 2103/20, D06F 2103/22, D06F 2103/68, D06F 2103/70, D06F 2105/50, D06F 2105/52, D06F 2105/54, D06F 2105/56, D06F 2105/58, D06F 2105/60, D06F 2105/62
C	D06F 37/10	3	Doors; Securing means therefor	D06F 37/10, D06F 34/20, D06F 2103/40, D06F 2105/44
C	D06F 37/18	3	Doors or covers; Securing means therefor	D06F 37/18, D06F 34/20, D06F 2103/40, D06F 2105/44
M	D06F 37/20	1	Mountings, e.g. resilient mountings, for the rotary receptacle, motor, tub or casing; Preventing or damping vibrations	
F	D06F 37/203	2	{ Arrangements for detecting or measuring unbalance; Preventing vibrations by regulating the speed of	D06F 33/48, D06F 33/76, D06F 34/08, D06F 34/16, D06F 2103/26, D06F 2103/46

CPC NOTICE OF CHANGES 808

DATE: FEBRUARY 1, 2020

PROJECT RP0608

<u>Type*</u>	<u>Symbol</u>	<u>Indent Level Number of dots (e.g. 0, 1, 2)</u>	<u>Title</u> <u>“CPC only” text should normally be enclosed in {curly brackets}**</u>	<u>Transferred to#</u>
			rotation of the drum (sensing vibrations to control introduction of counterbalancing liquid D06F37/225, D06F37/245)}	
C	D06F 37/22	2	in machines with a receptacle rotating or oscillating about a horizontal axis	D06F 37/22, D06F 33/48, D06F 33/76, D06F 34/08, D06F 34/16
C	D06F 37/225	3	{Damping vibrations by displacing, supplying or ejecting a material, e.g. liquid, into or from counterbalancing pockets}	D06F 37/225, D06F 33/48, D06F 33/76, D06F 34/08, D06F 34/16
C	D06F 37/24	2	in machines with a receptacle rotating or oscillating about a vertical axis	D06F 37/24, D06F 33/48, D06F 33/76, D06F 34/08, D06F 34/16
C	D06F 37/245	3	{Damping vibrations by displacing, supplying or ejecting a material, e.g. liquid, into or from counterbalancing pockets}	D06F 37/245, D06F 33/48, D06F 33/76, D06F 34/08, D06F 34/16
C	D06F 37/28	2	Doors; Security means therefor	D06F 37/28, D06F 34/20
C	D06F 37/30	1	Driving arrangements (control circuits or arrangements D06F 34/08)	D06F 37/30, D06F 34/08, D06F 34/10
C	D06F 37/302	2	{Automatic drum positioning}	D06F 37/302, D06F 34/20, D06F 2103/40, D06F 2105/44
C	D06F 37/304	2	{Arrangements or adaptations of electric motors}	D06F 37/304, D06F 34/08, D06F 34/10, D06F 2103/24, D06F 2103/46, D06F 2105/46, D06F 2105/48
F	D06F 37/306	3	{Control of the reversing movement}	D06F 34/08, D06F 34/10
C	D06F 37/42	1	Safety arrangements, e.g. for stopping rotation of the receptacle upon opening of the casing door	D06F 37/42, D06F 34/10, D06F 34/20, D06F 2103/40, D06F 2103/44, D06F 2105/44, D06F 2105/50, D06F 2105/62
C	D06F 39/00	0	Details of washing machines not specific to a single type of machines covered by groups D06F 9/00- D06F 27/00 (control of washing machines D06F 33/00, D06F 34/00)	D06F 39/00, D06F 31/00, D06F 31/005, D06F 33/00, D06F 33/04, D06F 33/06, D06F 33/08, D06F 33/10, D06F 33/30, D06F 33/32, D06F 33/34, D06F 33/36, D06F 33/37, D06F 33/38, D06F 33/40, D06F 33/42, D06F 33/43, D06F 33/44, D06F 33/46, D06F 33/47, D06F 33/48, D06F 33/50, D06F 33/52, D06F 33/54, D06F 33/56, D06F 33/57,

CPC NOTICE OF CHANGES 808

DATE: FEBRUARY 1, 2020

PROJECT RP0608

<u>Type*</u>	<u>Symbol</u>	<u>Indent Level Number of dots (e.g. 0, 1, 2)</u>	<u>Title</u> <u>“CPC only” text should normally be enclosed in {curly brackets}**</u>	<u>Transferred to#</u>
				D06F 33/58, D06F 33/60, D06F 33/62, D06F 33/63, D06F 33/64, D06F 33/65, D06F 33/68, D06F 33/69, D06F 33/70, D06F 33/72, D06F 33/74, D06F 33/76, D06F 34/00, D06F 34/04, D06F 34/05, D06F 34/06, D06F 34/08, D06F 34/10, D06F 34/14, D06F 34/16, D06F 34/18, D06F 34/20, D06F 34/22, D06F 34/24, D06F 34/26, D06F 34/28, D06F 34/30, D06F 34/32, D06F 34/34, D06F 37/42, D06F 58/32, D06F 58/34, D06F 58/36, D06F 58/38, D06F 58/40, D06F 58/42, D06F 58/44, D06F 58/45, D06F 58/46, D06F 58/48, D06F 58/50, D06F 58/52, D06F 2101/00, D06F 2101/02, D06F 2101/04, D06F 2101/06, D06F 2101/10, D06F 2101/12, D06F 2101/14, D06F 2101/16, D06F 2101/18, D06F 2101/20, D06F 2103/00, D06F 2103/02, D06F 2103/04, D06F 2103/06, D06F 2103/08, D06F 2103/10, D06F 2103/12, D06F 2103/14, D06F 2103/16, D06F 2103/18, D06F 2103/20, D06F 2103/22, D06F 2103/24, D06F 2103/26, D06F 2103/28, D06F 2103/30, D06F 2103/32, D06F 2103/34, D06F 2103/36, D06F 2103/38, D06F 2103/40, D06F 2103/42, D06F 2103/44, D06F 2103/46, D06F 2103/48, D06F 2103/50, D06F 2103/52, D06F 2103/54, D06F 2103/56, D06F 2103/58, D06F 2103/60, D06F 2103/62, D06F 2103/64, D06F 2103/66, D06F 2103/68, D06F 2103/70, D06F 2105/00, D06F 2105/02, D06F 2105/04, D06F 2105/06,

CPC NOTICE OF CHANGES 808

DATE: FEBRUARY 1, 2020

PROJECT RP0608

<u>Type*</u>	<u>Symbol</u>	<u>Indent Level Number of dots (e.g. 0, 1, 2)</u>	<u>Title</u> <u>“CPC only” text should normally be enclosed in {curly brackets}**</u>	<u>Transferred to#</u>
				D06F 2105/08, D06F 2105/10, D06F 2105/12, D06F 2105/14, D06F 2105/16, D06F 2105/18, D06F 2105/20, D06F 2105/22, D06F 2105/24, D06F 2105/26, D06F 2105/28, D06F 2105/30, D06F 2105/32, D06F 2105/34, D06F 2105/36, D06F 2105/38, D06F 2105/40, D06F 2105/42, D06F 2105/44, D06F 2105/46, D06F 2105/48, D06F 2105/50, D06F 2105/52, D06F 2105/54, D06F 2105/56, D06F 2105/58, D06F 2105/60, D06F 2105/62
D	D06F 39/002	1	{Arrangements for detecting or measuring the condition of the laundry or the washing water, e.g. nature or weight of the laundry, turbidity of the washing water}	<Administrative transfer to D06F34/18 and D06F34/22 simultaneously>
D	D06F 39/003	2	{Arrangements for measuring or detecting the condition of the laundry, e.g. nature or weight}	<Administrative transfer to D06F34/18>
D	D06F 39/004	2	{Arrangements for measuring or detecting the condition of the washing water, e.g. turbidity}	<Administrative transfer to D06F34/22>
D	D06F 39/005	1	{Arrangements for programme selection; Indication of the selected programme, programme progress or other variables, e.g. temperature (time-programme switches H01H43/00)}	<Administrative transfer to D06F34/28>
C	D06F 39/006	1	{Recovery arrangements, e.g. for the recovery of energy or water}	D06F 39/006, D06F 33/46, D06F 33/72, D06F 34/08, D06F 34/24, D06F 2103/44, D06F 2103/46, D06F 2103/50, D06F 2105/26
C	D06F 39/007	1	{Arrangements of water softeners}	D06F 39/007, D06F 2103/20
C	D06F 39/008	1	{Steam generating arrangements}	D06F 39/008, D06F 33/65, D06F 2103/62, D06F 2105/40
C	D06F 39/02	1	Devices for adding soap or other washing agents	D06F 39/02, D06F 33/37, D06F 33/57, D06F 2103/22
C	D06F 39/022	2	{in a liquid state (D06F39/024 takes precedence)}	D06F 39/022, D06F 33/37, D06F 33/57, D06F 34/08, D06F 2103/22, D06F 2105/58, D06F 2105/60

CPC NOTICE OF CHANGES 808

DATE: FEBRUARY 1, 2020

PROJECT RP0608

Type*	Symbol	Indent Level Number of dots (e.g. 0, 1, 2)	Title <u>“CPC only” text should normally be enclosed in {curly brackets}**</u>	Transferred to#
C	D06F 39/024	2	{mounted on the agitator or the rotating drum; Free body dispensers }	D06F 39/024, D06F 33/37, D06F 33/57, D06F 2103/22
C	D06F 39/026	2	{the powder or tablets being added directly, e.g. without the need of a flushing liquid }	D06F 39/026, D06F 33/37, D06F 33/57, D06F 2103/22
C	D06F 39/028	2	{Arrangements for selectively supplying water to detergent compartments }	D06F 39/028, D06F 33/37, D06F 33/57, D06F 2103/22
C	D06F 39/04	1	Heating arrangements	D06F 39/04, D06F 34/08, D06F 34/24, D06F 2103/52, D06F 2103/64, D06F 2105/10, D06F 2105/28
F	D06F 39/045	2	{Temperature measuring or regulating devices }	D06F 34/24, D06F 39/04, D06F 2103/16, D06F 2105/10
C	D06F 39/06	1	Arrangements for preventing or destroying scum	D06F 39/06, D06F 34/08, D06F 2105/50, D06F 2105/58, D06F 2105/60, D06F 2105/62
C	D06F 39/08	1	Liquid supply or discharge arrangements (supply of soap or other washing agents D06F 39/02)	D06F 39/08, D06F 33/42, D06F 33/47, D06F 33/62, D06F 33/74, D06F 37/42
C	D06F 39/081	2	{Safety arrangements for preventing water damage }	D06F 39/081, D06F 33/47, D06F 33/74, D06F 34/10, D06F 37/42, D06F 2105/58, D06F 2105/60
C	D06F 39/082	3	{detecting faulty draining operations, e.g. filter blockage, faulty pump }	D06F 39/082, D06F 33/47, D06F 33/74, D06F 37/42, D06F 2103/42, D06F 2103/48, D06F 2105/58, D06F 2105/60
C	D06F 39/083	2	{Liquid discharge or recirculation arrangements }	D06F 39/083, D06F 33/42, D06F 33/47, D06F 33/62, D06F 33/74, D06F 37/42
C	D06F 39/085	3	{Arrangements or adaptations of pumps }	D06F 39/085, D06F 33/42, D06F 33/47, D06F 33/62, D06F 33/74, D06F 37/42, D06F 2103/42, D06F 2103/48
C	D06F 39/086	3	{Arrangements for avoiding detergent wastage in the discharge conduit }	D06F 39/086, D06F 33/47, D06F 33/74, D06F 37/42
C	D06F 39/087	2	{Water level measuring or regulating devices }	D06F 39/087, D06F 33/47, D06F 33/74, D06F 37/42, D06F 2103/18
C	D06F 39/088	2	{Liquid supply arrangements }	D06F 39/088, D06F 33/47, D06F 33/74, D06F 37/42
C	D06F 39/10	1	Filtering arrangements	D06F 39/10, D06F 2103/42
C	D06F 39/12	1	Casings; Tubs	D06F 39/12, D06F 34/10, D06F 34/20

CPC NOTICE OF CHANGES 808

DATE: FEBRUARY 1, 2020

PROJECT RP0608

<u>Type*</u>	<u>Symbol</u>	<u>Indent Level Number of dots (e.g. 0, 1, 2)</u>	<u>Title</u> <u>“CPC only” text should normally be enclosed in {curly brackets}**</u>	<u>Transferred to#</u>
C	D06F 39/125	2	{Supporting arrangements for the casing, e.g. rollers or legs }	D06F 39/125, D06F 34/20
C	D06F 39/14	2	Doors or covers; Securing means therefor	D06F 39/14, D06F 33/47, D06F 33/74, D06F 34/10, D06F 34/20, D06F 37/42, D06F 2103/40, D06F 2105/44
M	D06F 43/08	1	Associated apparatus for handling and recovering the solvents	
M	D06F 45/14	1	with means for removable attachment to washing machines, tables or other supports	
M	D06F 49/00	0	Domestic spin-dryers or similar spin-dryers not suitable for industrial use	
M	D06F 49/06	1	Mountings, e.g. resilient mountings, for the bowl or casings; Preventing or damping vibrations	
M	D06F 53/00	0	Clothes-lines; Supports therefor (drying frames incorporating clothes-lines D06F 57/00)	
M	D06F 53/04	1	Supports, e.g. poles, props for clothes-lines	
M	D06F 57/00	0	Supporting means, other than simple clothes-lines, for linen or garments to be dried or aired (in combination with means for heating or positive air circulation D06F 58/00; adapted to retain the shape of particular articles being dried D06F 59/00)	
C	D06F 58/00	0	Domestic laundry dryers	D06F 58/00, D06F 33/50, D06F 33/52, D06F 33/54, D06F 33/56, D06F 33/57, D06F 33/58, D06F 33/60, D06F 33/62, D06F 33/63, D06F 33/64, D06F 33/65, D06F 33/68, D06F 33/69, D06F 33/70, D06F 33/72, D06F 33/74, D06F 33/76, D06F 34/00, D06F 34/04, D06F 34/05, D06F 34/06, D06F 34/08, D06F 34/10, D06F 34/14, D06F 34/16, D06F 34/18, D06F 34/20, D06F 34/22, D06F 34/24, D06F 34/26, D06F 34/28, D06F 34/30, D06F 34/32,

CPC NOTICE OF CHANGES 808

DATE: FEBRUARY 1, 2020

PROJECT RP0608

<u>Type*</u>	<u>Symbol</u>	<u>Indent Level Number of dots (e.g. 0, 1, 2)</u>	<u>Title</u> <u>“CPC only” text should normally be enclosed in {curly brackets}**</u>	<u>Transferred to#</u>
				D06F 34/34, D06F 37/42, D06F 58/30, D06F 58/32, D06F 58/34, D06F 58/36, D06F 58/38, D06F 58/40, D06F 58/42, D06F 58/44, D06F 58/45, D06F 58/46, D06F 58/48, D06F 58/50, D06F 58/52, D06F 2101/00, D06F 2101/02, D06F 2101/04, D06F 2101/06, D06F 2101/10, D06F 2101/12, D06F 2101/14, D06F 2101/16, D06F 2101/18, D06F 2101/20, D06F 2103/00, D06F 2103/02, D06F 2103/04, D06F 2103/06, D06F 2103/08, D06F 2103/10, D06F 2103/12, D06F 2103/14, D06F 2103/16, D06F 2103/18, D06F 2103/20, D06F 2103/22, D06F 2103/24, D06F 2103/26, D06F 2103/28, D06F 2103/30, D06F 2103/32, D06F 2103/34, D06F 2103/36, D06F 2103/38, D06F 2103/40, D06F 2103/42, D06F 2103/44, D06F 2103/46, D06F 2103/48, D06F 2103/50, D06F 2103/52, D06F 2103/54, D06F 2103/56, D06F 2103/58, D06F 2103/60, D06F 2103/62, D06F 2103/64, D06F 2103/66, D06F 2103/68, D06F 2103/70, D06F 2105/00, D06F 2105/02, D06F 2105/04, D06F 2105/06, D06F 2105/08, D06F 2105/10, D06F 2105/12, D06F 2105/14, D06F 2105/16, D06F 2105/18, D06F 2105/20, D06F 2105/22, D06F 2105/24, D06F 2105/26, D06F 2105/28, D06F 2105/30, D06F 2105/32, D06F 2105/34, D06F 2105/36, D06F 2105/38, D06F 2105/40, D06F 2105/42, D06F 2105/44, D06F 2105/46, D06F 2105/48, D06F 2105/50, D06F 2105/52, D06F 2105/54, D06F 2105/56,

CPC NOTICE OF CHANGES 808

DATE: FEBRUARY 1, 2020

PROJECT RP0608

<u>Type*</u>	<u>Symbol</u>	<u>Indent Level Number of dots (e.g. 0, 1, 2)</u>	<u>Title</u> <u>“CPC only” text should normally be enclosed in {curly brackets}**</u>	<u>Transferred to#</u>
				D06F 2105/58, D06F 2105/60, D06F 2105/62
C	D06F 58/02	1	having dryer drums rotating about a horizontal axis	D06F 58/02, D06F 33/50, D06F 33/52, D06F 33/54, D06F 33/56, D06F 33/57, D06F 33/58, D06F 33/60, D06F 33/62, D06F 33/63, D06F 33/64, D06F 33/65, D06F 33/68, D06F 33/69, D06F 33/70, D06F 33/72, D06F 33/74, D06F 34/00, D06F 34/04, D06F 34/05, D06F 34/06, D06F 34/08, D06F 34/10, D06F 34/14, D06F 34/16, D06F 34/18, D06F 34/20, D06F 34/22, D06F 34/24, D06F 34/26, D06F 34/28, D06F 34/30, D06F 34/32, D06F 34/34, , D06F37/42, D06F 58/30, D06F 58/32, D06F 58/34, D06F 58/36, D06F 58/38, D06F 58/40, D06F 58/42, D06F 58/44, D06F 58/45, D06F 58/46, D06F 58/48, D06F 58/50, D06F 58/52, D06F 2101/00, D06F 2101/02, D06F 2101/04, D06F 2101/06, D06F 2101/10, D06F 2101/12, D06F 2101/14, D06F 2101/16, D06F 2101/18, D06F 2101/20, D06F 2103/00, D06F 2103/02, D06F 2103/04, D06F 2103/06, D06F 2103/08, D06F 2103/10, D06F 2103/12, D06F 2103/14, D06F 2103/16, D06F 2103/18, D06F 2103/20, D06F 2103/22, D06F 2103/24, D06F 2103/26, D06F 2103/28, D06F 2103/30, D06F 2103/32, D06F 2103/34, D06F 2103/36, D06F 2103/38, D06F 2103/40, D06F 2103/42, D06F 2103/44, D06F 2103/46, D06F 2103/48, D06F 2103/50, D06F 2103/52, D06F 2103/54, D06F 2103/56, D06F 2103/58,

CPC NOTICE OF CHANGES 808

DATE: FEBRUARY 1, 2020

PROJECT RP0608

<u>Type*</u>	<u>Symbol</u>	<u>Indent Level Number of dots (e.g. 0, 1, 2)</u>	<u>Title</u> <u>“CPC only” text should normally be enclosed in {curly brackets}**</u>	<u>Transferred to#</u>
				D06F 2103/60, D06F 2103/62, D06F 2103/64, D06F 2103/66, D06F 2103/68, D06F 2103/70, D06F 2105/00, D06F 2105/02, D06F 2105/04, D06F 2105/06, D06F 2105/08, D06F 2105/10, D06F 2105/12, D06F 2105/14, D06F 2105/16, D06F 2105/18, D06F 2105/20, D06F 2105/22, D06F 2105/24, D06F 2105/26, D06F 2105/28, D06F 2105/30, D06F 2105/32, D06F 2105/34, D06F 2105/36, D06F 2105/38, D06F 2105/40, D06F 2105/42, D06F 2105/46, D06F 2105/48, D06F 2105/50, D06F 2105/52, D06F 2105/54, D06F 2105/56, D06F 2105/58, D06F 2105/60, D06F 2105/62
C	D06F 58/04	2	Details (controlling or regulating devices D06F 34/00)	D06F 58/04, D06F 34/00, D06F 34/04, D06F 34/05, D06F 34/06, D06F 34/08, D06F 34/10, D06F 34/14, D06F 34/16, D06F 34/18, D06F 34/20, D06F 34/22, D06F 34/24, D06F 34/26, D06F 34/28, D06F 34/30, D06F 34/32, D06F 34/34, D06F 2101/00, D06F 2101/02, D06F 2101/04, D06F 2101/06, D06F 2101/10, D06F 2101/12, D06F 2101/14, D06F 2101/16, D06F 2101/18, D06F 2101/20, D06F 2103/02, D06F 2103/04, D06F 2103/06, D06F 2103/08, D06F 2103/20, D06F 2103/22, D06F 2103/40, D06F 2103/68, D06F 2103/70, D06F 2105/44, D06F 2105/50, D06F 2105/52, D06F 2105/54, D06F 2105/56, D06F 2105/58, D06F 2105/60, D06F 2105/62
C	D06F 58/08	3	Driving arrangements	D06F 58/08, D06F 34/10, D06F 2103/44, D06F 2103/46, D06F 2105/46, D06F 2105/48

CPC NOTICE OF CHANGES 808

DATE: FEBRUARY 1, 2020

PROJECT RP0608

<u>Type*</u>	<u>Symbol</u>	<u>Indent Level Number of dots (e.g. 0, 1, 2)</u>	<u>Title</u> <u>“CPC only” text should normally be enclosed in {curly brackets}**</u>	<u>Transferred to#</u>
C	D06F 58/10	1	Drying cabinets or drying chambers having heating or ventilating means	D06F 58/10, D06F 34/26
C	D06F 58/12	2	having conveying means for moving clothes, e.g. along an endless track	D06F 58/12, D06F 34/26
C	D06F 58/14	2	Collapsible drying cabinets; Wall mounted collapsible hoods	D06F 58/14, D06F 34/26
C	D06F 58/20	1	General details of domestic laundry dryers (D06F 59/00 takes precedence)	D06F 58/20, D06F 33/63, D06F 33/64, D06F 34/04, D06F 34/05, D06F 34/10, D06F 34/16, D06F 34/18, D06F 34/20, D06F 34/26, D06F 34/28, D06F 34/30, D06F 34/32, D06F 34/34, D06F 58/45, D06F 58/52, D06F 2101/00, D06F 2101/02, D06F 2101/04, D06F 2101/06, D06F 2101/10, D06F 2101/12, D06F 2101/14, D06F 2101/16, D06F 2101/18, D06F 2101/20, D06F 2103/02, D06F 2103/04, D06F 2103/06, D06F 2103/08, D06F 2103/40, D06F 2103/54, D06F 2103/56, D06F 2103/68, D06F 2103/70, D06F 2105/30, D06F 2105/32, D06F 2105/36, D06F 2105/44, D06F 2105/50, D06F 2105/52, D06F 2105/54, D06F 2105/56, D06F 2105/58, D06F 2105/60, D06F 2105/62
C	D06F 58/203	2	{Laundry conditioning arrangements }	D06F 58/203, D06F 33/50, D06F 33/52, D06F 33/54, D06F 33/56, D06F 33/57, D06F 33/58, D06F 33/60, D06F 33/62, D06F 33/63, D06F 33/64, D06F 33/65, D06F 33/68, D06F 33/69, D06F 33/70, D06F 33/72, D06F 33/74, D06F 33/76, D06F 34/00, D06F 34/04, D06F 34/05, D06F 34/06, D06F 34/08, D06F 34/10, D06F 34/14, D06F 34/16, D06F 34/18, D06F 34/20, D06F 34/22, D06F 34/24, D06F 34/26, D06F 34/28, D06F 34/30, D06F 34/32,

CPC NOTICE OF CHANGES 808

DATE: FEBRUARY 1, 2020

PROJECT RP0608

<u>Type*</u>	<u>Symbol</u>	<u>Indent Level Number of dots (e.g. 0, 1, 2)</u>	<u>Title</u> <u>“CPC only” text should normally be enclosed in {curly brackets}**</u>	<u>Transferred to#</u>
				D06F 34/34, D06F 37/42, D06F 58/30, D06F 58/32, D06F 58/34, D06F 58/36, D06F 58/38, D06F 58/40, D06F 58/42, D06F 58/44, D06F 58/45, D06F 58/46, D06F 58/48, D06F 58/50, D06F 58/52, D06F 2101/00, D06F 2101/02, D06F 2101/04, D06F 2101/06, D06F 2101/10, D06F 2101/12, D06F 2101/14, D06F 2101/16, D06F 2101/18, D06F 2101/20, D06F 2103/00, D06F 2103/02, D06F 2103/04, D06F 2103/06, D06F 2103/08, D06F 2103/10, D06F 2103/12, D06F 2103/14, D06F 2103/16, D06F 2103/18, D06F 2103/20, D06F 2103/22, D06F 2103/24, D06F 2103/26, D06F 2103/28, D06F 2103/30, D06F 2103/32, D06F 2103/34, D06F 2103/36, D06F 2103/38, D06F 2103/40, D06F 2103/42, D06F 2103/44, D06F 2103/46, D06F 2103/48, D06F 2103/50, D06F 2103/52, D06F 2103/54, D06F 2103/56, D06F 2103/58, D06F 2103/60, D06F 2103/62, D06F 2103/64, D06F 2103/66, D06F 2103/68, D06F 2103/70, D06F 2105/00, D06F 2105/02, D06F 2105/04, D06F 2105/06, D06F 2105/08, D06F 2105/10, D06F 2105/12, D06F 2105/14, D06F 2105/16, D06F 2105/18, D06F 2105/20, D06F 2105/22, D06F 2105/24, D06F 2105/26, D06F 2105/28, D06F 2105/30, D06F 2105/32, D06F 2105/34, D06F 2105/36, D06F 2105/38, D06F 2105/40, D06F 2105/42, D06F 2105/44, D06F 2105/46, D06F 2105/48, D06F 2105/50, D06F 2105/52, D06F 2105/54, D06F 2105/56,

CPC NOTICE OF CHANGES 808

DATE: FEBRUARY 1, 2020

PROJECT RP0608

<u>Type*</u>	<u>Symbol</u>	<u>Indent Level Number of dots (e.g. 0, 1, 2)</u>	<u>Title</u> <u>“CPC only” text should normally be enclosed in {curly brackets}**</u>	<u>Transferred to#</u>
				D06F 2105/58, D06F 2105/60, D06F 2105/62
C	D06F 58/206	2	{Heat pump arrangements}	D06F 58/206, D06F 58/48, D06F 2103/50, D06F 2105/26
C	D06F 58/22	2	Lint collecting arrangements	D06F 58/22, D06F 58/45, D06F 2105/34
C	D06F 58/24	2	Condensing arrangements	D06F 58/24, D06F 58/45, D06F 2103/58, D06F 2105/36
C	D06F 58/26	2	Heating arrangements, e.g. gas heating equipment (D06F58/18 takes precedence)	D06F 58/26, D06F 2103/52, D06F 2105/28
C	D06F 58/263	3	{Gas heating equipment}	D06F 58/263, D06F 2103/52, D06F 2105/28
C	D06F 58/266	3	{Microwave heating equipment}	D06F 58/266, D06F 2103/52, D06F 2103/64, D06F 2105/28
D	D06F 58/28	2	Controlling or regulating (controlling or regulating in general G05)	<Administrative transfer to D06F58/30>
D	D06F 2058/2803	3	{Manual setting}	<Administrative transfer to D06F2101/00>
D	D06F 2058/2806	4	{of intensity of heater, motor or blower}	<Administrative transfer to D06F58/38 and D06F2101/00 simultaneously>
D	D06F 2058/2809	4	{of load, quantity, weight, type of laundry or the like}	<Administrative transfer to D06F58/38 and D06F2101/02 simultaneously>
D	D06F 2058/2812	4	{of rough drying time or timing for part of the programme}	<Administrative transfer to D06F58/38 and D06F2101/14 simultaneously>
D	D06F 2058/2816	3	{Automatic detection of the humidity or dryness of the laundry directly or indirectly by measuring}	<Administrative transfer to D06F58/38>
D	D06F 2058/2819	4	{the air humidity}	<Administrative transfer to D06F58/38 and D06F2103/08 simultaneously>
D	D06F 2058/2822	5	{the air humidity by capacitance}	<Administrative transfer to D06F58/38 and D06F2103/10 simultaneously>
D	D06F 2058/2825	5	{the air humidity by resistance}	<Administrative transfer to D06F58/38 and D06F2103/10 simultaneously>
D	D06F 2058/2829	4	{the air temperature}	<Administrative transfer to D06F58/38 and D06F2103/08 simultaneously>

CPC NOTICE OF CHANGES 808

DATE: FEBRUARY 1, 2020

PROJECT RP0608

<u>Type*</u>	<u>Symbol</u>	<u>Indent Level Number of dots (e.g. 0, 1, 2)</u>	<u>Title</u> <u>“CPC only” text should normally be enclosed in {curly brackets}**</u>	<u>Transferred to#</u>
D	D06F 2058/2832	4	{the variation of quantities in the condenser, e.g. water temperature}	<Administrative transfer to D06F58/38 and D06F2103/08 simultaneously>
D	D06F 2058/2835	4	{the laundry electrical capacitance}	<Administrative transfer to D06F58/38 and D06F2103/10 simultaneously>
D	D06F 2058/2838	4	{the laundry electrical resistance}	<Administrative transfer to D06F58/38 and D06F2103/10 simultaneously>
D	D06F 2058/2841	4	{the laundry temperature}	<Administrative transfer to D06F58/38 and D06F2103/12 simultaneously>
D	D06F 2058/2845	4	{by means of radiation}	<Administrative transfer to D06F58/38, D06F2103/08 and D06F2103/64 simultaneously>
D	D06F 2058/2848	4	{the variation of the weight}	<Administrative transfer to D06F58/38 and D06F2103/04 simultaneously>
D	D06F 2058/2851	4	{the time necessary for a cooling-down or a heating-up period}	<Administrative transfer to D06F58/38 and D06F2103/38 simultaneously>
D	D06F 2058/2854	3	{Other automatic detection}	<Administrative transfer to D06F2103/00 >
D	D06F 2058/2858	4	{Controlling the correct functioning of the machine; Security (D06F2058/2861 and D06F2058/2887 take precedence)}	<Administrative transfer to D06F58/50 >
D	D06F 2058/2861	4	{Load, type of laundry, weight, e.g. overload}	<Administrative transfer to D06F2103/02>
D	D06F 2058/2864	3	{Air quantity; Control of the blower; Mixing with fresh air}	<Administrative transfer to D06F2103/36 and D06F2105/24 simultaneously>
D	D06F 2058/2867	4	{Control by ON/OFF timing}	<Administrative transfer to D06F2103/36 and D06F2105/24 simultaneously>
D	D06F 2058/287	3	{Control of the heat pump}	<Administrative transfer to D06F2103/50 and D06F2105/26 simultaneously>
D	D06F 2058/2874	4	{by ON/OFF timing}	<Administrative transfer to D06F2103/50 and D06F2105/26 simultaneously>
D	D06F 2058/2877	3	{Driving motor control}	<Administrative transfer to D06F2103/00, D06F2103/34, D06F2103/44 and D06F2105/46 simultaneously>

CPC NOTICE OF CHANGES 808

DATE: FEBRUARY 1, 2020

PROJECT RP0608

<u>Type*</u>	<u>Symbol</u>	<u>Indent Level Number of dots (e.g. 0, 1, 2)</u>	<u>Title</u> <u>“CPC only” text should normally be enclosed in {curly brackets}**</u>	<u>Transferred to#</u>
D	D06F 2058/288	4	{by ON/OFF timing}	<Administrative transfer to D06F2103/00, D06F2103/34, D06F2103/44 and D06F2105/46 simultaneously>
D	D06F 2058/2883	3	{Displaying or monitoring the programme progress}	<Administrative transfer to D06F34/28 >
D	D06F 2058/2887	4	{Warning to signal incorrect functioning of the machine}	<Administrative transfer to D06F34/28 and D06F2105/58 simultaneously>
D	D06F 2058/289	3	{Heater control}	<Administrative transfer to D06F2105/28>
D	D06F 2058/2893	4	{by ON/OFF timing}	<Administrative transfer to D06F2105/28>
D	D06F 2058/2896	3	{Timing in general; Timing of a part of the cycle, e.g. cooling-down period}	<Administrative transfer to D06F2103/38>
Q	D06F 58/30	1	Drying processes (controlling a series of operations in domestic laundry dryers D06F 58/32)	D06F 58/30, D06F 33/50, D06F 33/52, D06F 33/54, D06F 33/56, D06F 33/57, D06F 33/58, D06F 33/60, D06F 33/62, D06F 33/63, D06F 33/64, D06F 33/65, D06F 33/68, D06F 33/69, D06F 33/70, D06F 33/72, D06F 33/74, D06F 33/76, D06F 34/00, D06F 34/04, D06F 34/05, D06F 34/06, D06F 34/08, D06F 34/10, D06F 34/14, D06F 34/16, D06F 34/18, D06F 34/20, D06F 34/22, D06F 34/24, D06F 34/26, D06F 34/28, D06F 34/30, D06F 34/32, D06F 34/34, D06F 37/42, D06F 58/32, D06F 58/34, D06F 58/36, D06F 58/38, D06F 58/40, D06F 58/42, D06F 58/44, D06F 58/45, D06F 58/46, D06F 58/48, D06F 58/50, D06F 58/52, D06F 2101/00, D06F 2101/02, D06F 2101/04, D06F 2101/06, D06F 2101/10, D06F 2101/12, D06F 2101/14, D06F 2101/16, D06F 2101/18, D06F 2101/20, D06F 2103/00, D06F 2103/02,

CPC NOTICE OF CHANGES 808

DATE: FEBRUARY 1, 2020

PROJECT RP0608

<u>Type*</u>	<u>Symbol</u>	<u>Indent Level Number of dots (e.g. 0, 1, 2)</u>	<u>Title</u> <u>“CPC only” text should normally be enclosed in {curly brackets}**</u>	<u>Transferred to#</u>
				D06F 2103/04, D06F 2103/06, D06F 2103/08, D06F 2103/10, D06F 2103/12, D06F 2103/14, D06F 2103/16, D06F 2103/18, D06F 2103/20, D06F 2103/22, D06F 2103/24, D06F 2103/26, D06F 2103/28, D06F 2103/30, D06F 2103/32, D06F 2103/34, D06F 2103/36, D06F 2103/38, D06F 2103/40, D06F 2103/42, D06F 2103/44, D06F 2103/46, D06F 2103/48, D06F 2103/50, D06F 2103/52, D06F 2103/54, D06F 2103/56, D06F 2103/58, D06F 2103/60, D06F 2103/62, D06F 2103/64, D06F 2103/66, D06F 2103/68, D06F 2103/70, D06F 2105/00, D06F 2105/02, D06F 2105/04, D06F 2105/06, D06F 2105/08, D06F 2105/10, D06F 2105/12, D06F 2105/14, D06F 2105/16, D06F 2105/18, D06F 2105/20, D06F 2105/22, D06F 2105/24, D06F 2105/26, D06F 2105/28, D06F 2105/30, D06F 2105/32, D06F 2105/34, D06F 2105/36, D06F 2105/38, D06F 2105/40, D06F 2105/42, D06F 2105/44, D06F 2105/46, D06F 2105/48, D06F 2105/50, D06F 2105/52, D06F 2105/54, D06F 2105/56, D06F 2105/58, D06F 2105/60, D06F 2105/62
N	D06F 58/32	1	Control of operations performed in domestic laundry dryers (control of operations performed in washer-dryers D06F 33/50; details of control systems, e.g. for detecting or measuring specific parameters or for selection or indication of programs D06F 34/00)	
N	D06F 58/34	2	characterised by the purpose or target of the control	
N	D06F 58/36	3	Control of operational steps, e.g. for optimisation or improvement of	

CPC NOTICE OF CHANGES 808

DATE: FEBRUARY 1, 2020

PROJECT RP0608

<u>Type*</u>	<u>Symbol</u>	<u>Indent Level Number of dots (e.g. 0, 1, 2)</u>	<u>Title</u> <u>“CPC only” text should normally be enclosed in {curly brackets}**</u>	<u>Transferred to#</u>
			operational steps depending on the condition of the laundry	
Q	D06F 58/38	4	of drying, e.g. to achieve the target humidity	D06F 58/38, D06F 58/40, D06F 58/42, D06F 2103/00, D06F 2103/02, D06F 2103/04, D06F 2103/06, D06F 2103/08, D06F 2103/10, D06F 2103/12, D06F 2103/14, D06F 2103/16, D06F 2103/18, D06F 2103/20, D06F 2103/22, D06F 2103/24, D06F 2103/26, D06F 2103/28, D06F 2103/30, D06F 2103/32, D06F 2103/34, D06F 2103/36, D06F 2103/38, D06F 2103/40, D06F 2103/42, D06F 2103/44, D06F 2103/46, D06F 2103/48, D06F 2103/50, D06F 2103/52, D06F 2103/54, D06F 2103/56, D06F 2103/58, D06F 2103/60, D06F 2103/62, D06F 2103/64, D06F 2103/66, D06F 2103/68, D06F 2103/70, D06F 2105/00, D06F 2105/02, D06F 2105/04, D06F 2105/06, D06F 2105/08, D06F 2105/10, D06F 2105/12, D06F 2105/14, D06F 2105/16, D06F 2105/18, D06F 2105/20, D06F 2105/22, D06F 2105/24, D06F 2105/26, D06F 2105/28, D06F 2105/30, D06F 2105/32, D06F 2105/34, D06F 2105/36, D06F 2105/38, D06F 2105/40, D06F 2105/42, D06F 2105/44, D06F 2105/46, D06F 2105/48, D06F 2105/50, D06F 2105/52, D06F 2105/54, D06F 2105/56
N	D06F 58/40	5	Control of the initial heating of the drying chamber to its operating temperature	
N	D06F 58/42	5	by unheated air	
N	D06F 58/44	4	of conditioning or finishing, e.g. for smoothing or removing creases	
N	D06F 58/45	3	Cleaning or disinfection of machine parts, e.g. of heat exchangers or filters	
N	D06F 58/46	3	Control of the operating time	

CPC NOTICE OF CHANGES 808

DATE: FEBRUARY 1, 2020

PROJECT RP0608

<u>Type*</u>	<u>Symbol</u>	<u>Indent Level Number of dots (e.g. 0, 1, 2)</u>	<u>Title</u> <u>“CPC only” text should normally be enclosed in {curly brackets}**</u>	<u>Transferred to#</u>
N	D06F 58/48	3	Control of the energy consumption	
Q	D06F 58/50	3	Responding to irregular working conditions, e.g. malfunctioning of blowers	D06F 58/50, D06F 2105/00, D06F 2105/02, D06F 2105/04, D06F 2105/06, D06F 2105/08, D06F 2105/10, D06F 2105/12, D06F 2105/14, D06F 2105/16, D06F 2105/18, D06F 2105/20, D06F 2105/22, D06F 2105/24, D06F 2105/26, D06F 2105/28, D06F 2105/30, D06F 2105/32, D06F 2105/34, D06F 2105/36, D06F 2105/38, D06F 2105/40, D06F 2105/42, D06F 2105/44, D06F 2105/46, D06F 2105/48, D06F 2105/50, D06F 2105/52, D06F 2105/54, D06F 2105/56, D06F 2105/58, D06F 2105/60, D06F 2105/62
N	D06F 58/52	3	Preventing or reducing noise	
M	D06F 59/00	0	Supports adapted to retain the shape of particular articles being dried, e.g. incorporating heating means {(devices for retaining the shape of hats A42B 1/002)}	
M	D06F 67/00	0	Details of ironing machines provided for in groups D06F 61/00, D06F 63/00, or D06F 65/00 (coverings or pads for ironing or pressing members D06F 83/00)	
M	D06F 67/02	1	Rollers; Heating arrangements therefor	
M	D06F 67/08	1	Beds; Heating arrangements therefor	
M	D06F 71/00	0	Apparatus for hot-pressing clothes, linen or other textile articles, i.e. wherein there is substantially no relative movement between pressing element and article while pressure is being applied to the article; Similar machines for cold-pressing clothes, linen or other textile articles	
M	D06F 71/08	1	wherein one or more of the pressing elements is moved laterally between successive pressing operations	
M	D06F 71/18	1	specially adapted for pressing particular garments or parts thereof	

CPC NOTICE OF CHANGES 808

DATE: FEBRUARY 1, 2020

PROJECT RP0608

<u>Type*</u>	<u>Symbol</u>	<u>Indent Level Number of dots (e.g. 0, 1, 2)</u>	<u>Title</u> <u>“CPC only” text should normally be enclosed in {curly brackets}**</u>	<u>Transferred to#</u>
M	D06F 71/30	1	specialy adapted for pressing seams (specialy adapted for pressing particular garments or parts thereof D06F 71/18)	
M	D06F 73/00	0	Apparatus for smoothing or removing creases from garments or other textile articles by formers, cores, stretchers, or internal frames, with the application of heat or steam (combined with external pressure means D06F 71/00)	
M	D06F 75/24	2	Arrangements of the heating means within the iron; Arrangements for distributing, conducting or storing the heat	
M	D06F 75/26	2	Temperature control or indicating arrangements	
M	D06F 79/04	1	Stoves or other heating means specially adapted for heating irons externally	
M	D06F 81/00	0	Ironing boards (coverings or pads therefor D06F 83/00; kitchen cabinets with ironing boards movable outwards to a position of use A47B 77/10)	
M	D06F 87/00	0	Apparatus for moistening or otherwise conditioning the article to be ironed or pressed (apparatus for smoothing or removing creases from garments or other textile articles by formers, cores, stretchers or internal frames, with the application of heat or steam D06F 73/00 {; devices used in combination with a laundry dryer D06F 58/203})	
M	D06F 95/00	0	Laundry systems or arrangements of apparatus or machines; Mobile laundries (D06F 31/00 takes precedence)	
U	D06F 95/008	1	{Devices for keeping articles together during laundering, e.g. for keeping socks in pairs (D06F95/004 takes precedence); Devices for protecting or shielding certain parts of the articles during laundering, e.g. button protectors}	

CPC NOTICE OF CHANGES 808

DATE: FEBRUARY 1, 2020

PROJECT RP0608

<u>Type*</u>	<u>Symbol</u>	<u>Indent Level Number of dots (e.g. 0, 1, 2)</u>	<u>Title</u> <u>“CPC only” text should normally be enclosed in {curly brackets}**</u>	<u>Transferred to#</u>
Q	D06F 2101/00	0	User input for the control of domestic laundry washing machines, washer-dryers or laundry dryers	D06F 2101/00, D06F 2101/02, D06F 2101/04, D06F 2101/06, D06F 2101/10, D06F 2101/12, D06F 2101/14, D06F 2101/16, D06F 2101/18, D06F 2101/20
N	D06F 2101/02	1	Characteristics of laundry or load	
N	D06F 2101/04	2	Quantity, e.g. weight	
N	D06F 2101/06	2	Type or material	
N	D06F 2101/10	1	Spin speed	
N	D06F 2101/12	1	Washing temperature	
N	D06F 2101/14	1	Time settings	
N	D06F 2101/16	1	Target humidity for the drying process, e.g. very-dry cycles	
N	D06F 2101/18	1	Target temperature for the drying process, e.g. low-temperature cycles	
N	D06F 2101/20	1	Operation modes, e.g. delicate laundry washing programs, service modes or refreshment cycles	
Q	D06F 2103/00	0	Parameters monitored or detected for the control of domestic laundry washing machines, washer-dryers or laundry dryers	D06F 2103/00, D06F 2103/02, D06F 2103/04, D06F 2103/06, D06F 2103/08, D06F 2103/10, D06F 2103/12, D06F 2103/14, D06F 2103/16, D06F 2103/18, D06F 2103/20, D06F 2103/22, D06F 2103/24, D06F 2103/26, D06F 2103/28, D06F 2103/30, D06F 2103/32, D06F 2103/34, D06F 2103/36, D06F 2103/38, D06F 2103/40, D06F 2103/42, D06F 2103/44, D06F 2103/46, D06F 2103/48, D06F 2103/50, D06F 2103/52, D06F 2103/54, D06F 2103/56, D06F 2103/58, D06F 2103/60, D06F 2103/62, D06F 2103/64, D06F 2103/66, D06F 2103/68, D06F 2103/70
N	D06F 2103/02	1	Characteristics of laundry or load	
N	D06F 2103/04	2	Quantity, e.g. weight or variation of weight	
N	D06F 2103/06	2	Type or material	
N	D06F 2103/08	2	Humidity	
N	D06F 2103/10	3	expressed as capacitance or resistance	
N	D06F 2103/12	2	Temperature	
N	D06F 2103/14	1	Supply, recirculation or draining of washing liquid	

CPC NOTICE OF CHANGES 808

DATE: FEBRUARY 1, 2020

PROJECT RP0608

<u>Type*</u>	<u>Symbol</u>	<u>Indent Level Number of dots (e.g. 0, 1, 2)</u>	<u>Title</u> <u>“CPC only” text should normally be enclosed in {curly brackets}**</u>	<u>Transferred to#</u>
N	D06F 2103/16	1	Washing liquid temperature	
N	D06F 2103/18	1	Washing liquid level	
N	D06F 2103/20	1	Washing liquid condition, e.g. turbidity	
N	D06F 2103/22	2	Content of detergent or additives	
N	D06F 2103/24	1	Spin speed; Drum movements	
N	D06F 2103/26	1	Unbalance; Noise level	
N	D06F 2103/28	1	Air properties	
N	D06F 2103/30	2	Pressure	
N	D06F 2103/32	2	Temperature	
N	D06F 2103/34	2	Humidity	
N	D06F 2103/36	2	Flow or velocity	
N	D06F 2103/38	1	Time, e.g. duration	
N	D06F 2103/40	1	Opening or locking status of doors	
N	D06F 2103/42	1	related to filters or pumps	
N	D06F 2103/44	1	Current or voltage	
N	D06F 2103/46	2	of the motor driving the drum	
N	D06F 2103/48	2	of the motor driving the pump	
N	D06F 2103/50	1	related to heat pumps, e.g. pressure or flow rate	
N	D06F 2103/52	1	related to electric heating means, e.g. temperature or voltage	
N	D06F 2103/54	1	related to blowers or fans	
N	D06F 2103/56	1	related to air ducts, e.g. position of flow diverters	
N	D06F 2103/58	1	related to condensation, e.g. condensate water level	
N	D06F 2103/60	1	related to auxiliary conditioning or finishing agents, e.g. filling level of perfume tanks	
N	D06F 2103/62	2	related to systems for water or steam used for conditioning or finishing	
N	D06F 2103/64	1	Radiation, e.g. microwaves	
N	D06F 2103/66	2	for treatment of laundry otherwise than by drying, e.g. using UV light	
N	D06F 2103/68	1	Operation mode; Program phase	
N	D06F 2103/70	1	Number of operational cycles	
N	D06F 2105/00	0	Systems or parameters controlled or affected by the control systems of washing machines, washer-dryers or laundry dryers	
N	D06F 2105/02	1	Water supply	
N	D06F 2105/04	2	from separate hot and cold water inlets	

CPC NOTICE OF CHANGES 808

DATE: FEBRUARY 1, 2020

PROJECT RP0608

<u>Type*</u>	<u>Symbol</u>	<u>Indent Level Number of dots (e.g. 0, 1, 2)</u>	<u>Title</u> <u>“CPC only” text should normally be enclosed in {curly brackets}**</u>	<u>Transferred to#</u>
N	D06F 2105/06	1	Recirculation of washing liquids, e.g. by pumps or diverting valves	
N	D06F 2105/08	1	Draining of washing liquids	
N	D06F 2105/10	1	Temperature of washing liquids; Heating means therefor	
N	D06F 2105/12	1	Humidity or dryness of laundry	
N	D06F 2105/14	1	Temperature of laundry	
N	D06F 2105/16	1	Air properties	
N	D06F 2105/18	2	Pressure	
N	D06F 2105/20	2	Temperature	
N	D06F 2105/22	2	Humidity	
N	D06F 2105/24	2	Flow or velocity	
N	D06F 2105/26	1	Heat pumps	
N	D06F 2105/28	1	Electric heating	
N	D06F 2105/30	1	Blowers	
N	D06F 2105/32	1	Air flow control means	
N	D06F 2105/34	1	Filtering , e.g. control of lint removal devices	
N	D06F 2105/36	1	Condensing arrangements, e.g. control of water injection therefor	
N	D06F 2105/38	1	Conditioning or finishing, e.g. control of perfume injection	
N	D06F 2105/40	2	using water or steam	
N	D06F 2105/42	1	Detergent or additive supply	
N	D06F 2105/44	1	Opening, closing or locking of doors	
N	D06F 2105/46	1	Drum speed; Actuation of motors, e.g. starting or interrupting	
N	D06F 2105/48	2	Drum speed	
N	D06F 2105/50	1	Starting machine operation, e.g. delayed start or re-start after power cut	
N	D06F 2105/52	1	Changing sequence of operational steps; Carrying out additional operational steps; Modifying operational steps, e.g. by extending duration of steps	
N	D06F 2105/54	1	Changing between normal operation mode and special operation modes, e.g. service mode, component cleaning mode or stand-by mode	
N	D06F 2105/56	1	Remaining operation time; Remaining operational cycles	
N	D06F 2105/58	1	Indications or alarms to the control system or to the user	
N	D06F 2105/60	2	Audible signals	

CPC NOTICE OF CHANGES 808

DATE: FEBRUARY 1, 2020

PROJECT RP0608

<u>Type*</u>	<u>Symbol</u>	<u>Indent Level Number of dots (e.g. 0, 1, 2)</u>	<u>Title</u> <u>“CPC only” text should normally be enclosed in {curly brackets}**</u>	<u>Transferred to#</u>
N	D06F 2105/62	1	Stopping or disabling machine operation	
F	D06F 2202/00	0	Input, e.g. measuring, checking variables (manual setting D06F 2214/00)	D06F 33/30, D06F 33/50, D06F 33/52, D06F 33/54, D06F 33/56, D06F 33/57, D06F 33/58, D06F 33/60, D06F 33/62, D06F 33/63, D06F 33/64, D06F 33/65, D06F 33/68, D06F 33/69, D06F 33/70, D06F 33/72, D06F 33/74, D06F 33/76, D06F 34/00, D06F 34/04, D06F 34/05, D06F 34/06, D06F 34/08, D06F 34/10, D06F 34/14, D06F 34/16, D06F 34/18, D06F 34/20, D06F 34/22, D06F 34/24, D06F 34/26, D06F 34/28, D06F 34/30, D06F 34/32, D06F 34/34, D06F 37/42, D06F 2101/00, D06F 2101/02, D06F 2101/04, D06F 2101/06, D06F 2101/10, D06F 2101/12, D06F 2101/14, D06F 2101/16, D06F 2101/18, D06F 2101/20, D06F 2103/00, D06F 2103/02, D06F 2103/04, D06F 2103/06, D06F 2103/08, D06F 2103/10, D06F 2103/12, D06F 2103/14, D06F 2103/16, D06F 2103/18, D06F 2103/20, D06F 2103/22, D06F 2103/24, D06F 2103/26, D06F 2103/28, D06F 2103/30, D06F 2103/32, D06F 2103/34, D06F 2103/36, D06F 2103/38, D06F 2103/40, D06F 2103/42, D06F 2103/44, D06F 2103/46, D06F 2103/48, D06F 2103/50, D06F 2103/52, D06F 2103/54, D06F 2103/56, D06F 2103/58, D06F 2103/60, D06F 2103/62, D06F 2103/64, D06F 2103/66, D06F 2103/68, D06F 2103/70, D06F 2105/50, D06F 2105/52, D06F 2105/54, D06F 2105/56,

CPC NOTICE OF CHANGES 808

DATE: FEBRUARY 1, 2020

PROJECT RP0608

<u>Type*</u>	<u>Symbol</u>	<u>Indent Level Number of dots (e.g. 0, 1, 2)</u>	<u>Title</u> <u>“CPC only” text should normally be enclosed in {curly brackets}**</u>	<u>Transferred to#</u>
				D06F 2105/58, D06F 2105/60, D06F 2105/62
F	D06F 2202/02	1	Chemical variables; Condition of the washing liquid	D06F 33/30, D06F 33/50, D06F 33/52, D06F 33/54, D06F 33/56, D06F 33/57, D06F 33/58, D06F 33/60, D06F 33/62, D06F 33/63, D06F 33/64, D06F 33/65, D06F 33/68, D06F 33/69, D06F 33/70, D06F 33/72, D06F 33/74, D06F 33/76, D06F 37/42, D06F 2103/20, D06F 2103/22
F	D06F 2202/04	1	Temperature	D06F 33/30, D06F 33/50, D06F 33/52, D06F 33/54, D06F 33/56, D06F 33/57, D06F 33/58, D06F 33/60, D06F 33/62, D06F 33/63, D06F 33/64, D06F 33/65, D06F 33/68, D06F 33/69, D06F 33/70, D06F 33/72, D06F 33/74, D06F 33/76, D06F 34/24, D06F 37/42, D06F 2103/16, D06F 2103/52
F	D06F 2202/06	1	Mechanical action on the laundry	D06F 33/30, D06F 33/50, D06F 33/52, D06F 33/54, D06F 33/56, D06F 33/57, D06F 33/58, D06F 33/60, D06F 33/62, D06F 33/63, D06F 33/64, D06F 33/65, D06F 33/68, D06F 33/69, D06F 33/70, D06F 33/72, D06F 33/74, D06F 33/76, D06F 37/42, D06F 2103/24, D06F 2103/46
F	D06F 2202/065	2	Rotational speed	D06F 33/30, D06F 33/50, D06F 33/52, D06F 33/54, D06F 33/56, D06F 33/57, D06F 33/58, D06F 33/60, D06F 33/62, D06F 33/63, D06F 33/64, D06F 33/65, D06F 33/68, D06F 33/69, D06F 33/70, D06F 33/72, D06F 33/74, D06F 33/76, D06F 37/42, D06F 2103/24, D06F 2103/46

CPC NOTICE OF CHANGES 808

DATE: FEBRUARY 1, 2020

PROJECT RP0608

<u>Type*</u>	<u>Symbol</u>	<u>Indent Level Number of dots (e.g. 0, 1, 2)</u>	<u>Title</u> <u>“CPC only” text should normally be enclosed in {curly brackets}**</u>	<u>Transferred to#</u>
F	D06F 2202/08	1	Liquid supply, circulation or discharge	D06F 33/30, D06F 33/50, D06F 33/52, D06F 33/54, D06F 33/56, D06F 33/57, D06F 33/58, D06F 33/60, D06F 33/62, D06F 33/63, D06F 33/64, D06F 33/65, D06F 33/68, D06F 33/69, D06F 33/70, D06F 33/72, D06F 33/74, D06F 33/76, D06F 37/42, D06F 2103/14, D06F 2103/42, D06F 2103/48
F	D06F 2202/085	2	Level	D06F 33/30, D06F 33/50, D06F 33/52, D06F 33/54, D06F 33/56, D06F 33/57, D06F 33/58, D06F 33/60, D06F 33/62, D06F 33/63, D06F 33/64, D06F 33/65, D06F 33/68, D06F 33/69, D06F 33/70, D06F 33/72, D06F 33/74, D06F 33/76, D06F 37/42, D06F 2103/18
F	D06F 2202/10	1	Nature or weight of the laundry	D06F 33/30, D06F 33/32, D06F 33/34, D06F 33/36, D06F 33/37, D06F 33/38, D06F 33/40, D06F 33/42, D06F 33/43, D06F 33/44, D06F 33/46, D06F 33/47, D06F 33/48, D06F 33/50, D06F 33/52, D06F 33/54, D06F 33/56, D06F 33/57, D06F 33/58, D06F 33/60, D06F 33/62, D06F 33/63, D06F 33/64, D06F 33/65, D06F 33/68, D06F 33/69, D06F 33/70, D06F 33/72, D06F 33/74, D06F 33/76, D06F 37/42, D06F 2103/02, D06F 2103/04, D06F 2103/06, D06F 2103/08, D06F 2103/66
F	D06F 2202/12	1	Other variables, e.g. variation of electrical quantities	D06F 33/30, D06F 33/36, D06F 33/50, D06F 33/52, D06F 33/54, D06F 33/56, D06F 33/57, D06F 33/58, D06F 33/60, D06F 33/62, D06F 33/63, D06F 33/64, D06F 33/65, D06F 33/68,

CPC NOTICE OF CHANGES 808

DATE: FEBRUARY 1, 2020

PROJECT RP0608

<u>Type*</u>	<u>Symbol</u>	<u>Indent Level Number of dots (e.g. 0, 1, 2)</u>	<u>Title</u> <u>“CPC only” text should normally be enclosed in {curly brackets}**</u>	<u>Transferred to#</u>
				D06F 33/69, D06F 33/70, D06F 33/72, D06F 33/74, D06F 33/76, D06F 34/00, D06F 34/04, D06F 34/05, D06F 34/06, D06F 34/08, D06F 34/10, D06F 34/14, D06F 34/16, D06F 34/18, D06F 34/20, D06F 34/22, D06F 34/24, D06F 34/26, D06F 34/28, D06F 34/30, D06F 34/32, D06F 34/34, D06F 37/42, D06F 2101/00, D06F 2101/02, D06F 2101/04, D06F 2101/06, D06F 2101/10, D06F 2101/12, D06F 2101/14, D06F 2101/16, D06F 2101/18, D06F 2101/20, D06F 2103/00, D06F 2103/02, D06F 2103/04, D06F 2103/06, D06F 2103/08, D06F 2103/10, D06F 2103/12, D06F 2103/14, D06F 2103/16, D06F 2103/18, D06F 2103/20, D06F 2103/22, D06F 2103/24, D06F 2103/26, D06F 2103/28, D06F 2103/30, D06F 2103/32, D06F 2103/34, D06F 2103/36, D06F 2103/38, D06F 2103/40, D06F 2103/42, D06F 2103/44, D06F 2103/46, D06F 2103/48, D06F 2103/50, D06F 2103/52, D06F 2103/54, D06F 2103/56, D06F 2103/58, D06F 2103/60, D06F 2103/62, D06F 2103/64, D06F 2103/66, D06F 2103/68, D06F 2103/70, D06F 2105/28, D06F 2105/40, D06F 2105/50, D06F 2105/52, D06F 2105/54, D06F 2105/56, D06F 2105/58, D06F 2105/60, D06F 2105/62
F	D06F 2204/00	0	Output, e.g. controlled quantity (display D06F 2216/00)	D06F 33/30, D06F 33/36, D06F 33/38, D06F 33/43, D06F 33/44, D06F 33/46, D06F 33/47, D06F 33/48, D06F 33/50, D06F 33/52, D06F 33/54, D06F 33/56, D06F 33/57, D06F 33/58,

CPC NOTICE OF CHANGES 808

DATE: FEBRUARY 1, 2020

PROJECT RP0608

<u>Type*</u>	<u>Symbol</u>	<u>Indent Level Number of dots (e.g. 0, 1, 2)</u>	<u>Title</u> <u>“CPC only” text should normally be enclosed in {curly brackets}**</u>	<u>Transferred to#</u>
				D06F 33/60, D06F 33/62, D06F 33/63, D06F 33/64, D06F 33/65, D06F 33/68, D06F 33/69, D06F 33/70, D06F 33/72, D06F 33/74, D06F 33/76, D06F 34/00, D06F 34/04, D06F 34/05, D06F 34/06, D06F 34/08, D06F 34/10, D06F 34/14, D06F 34/16, D06F 34/18, D06F 34/20, D06F 34/22, D06F 34/24, D06F 34/26, D06F 34/28, D06F 34/30, D06F 34/32, D06F 34/34, D06F 37/42, D06F 2101/00, D06F 2101/02, D06F 2101/04, D06F 2101/06, D06F 2101/10, D06F 2101/12, D06F 2101/14, D06F 2101/16, D06F 2101/18, D06F 2101/20, D06F 2103/02, D06F 2103/04, D06F 2103/06, D06F 2103/08, D06F 2103/20, D06F 2103/22, D06F 2103/68, D06F 2103/70, D06F 2105/00, D06F 2105/50, D06F 2105/52, D06F 2105/54, D06F 2105/56, D06F 2105/58, D06F 2105/60, D06F 2105/62
F	D06F 2204/02	1	Chemical quantities	D06F 33/30, D06F 33/36, D06F 33/37, D06F 33/38, D06F 33/43, D06F 33/44, D06F 33/46, D06F 33/47, D06F 33/48, D06F 33/50, D06F 33/52, D06F 33/54, D06F 33/56, D06F 33/57, D06F 33/58, D06F 33/60, D06F 33/62, D06F 33/63, D06F 33/64, D06F 33/65, D06F 33/68, D06F 33/69, D06F 33/70, D06F 33/72, D06F 33/74, D06F 33/76, D06F 37/42, D06F 2105/42
F	D06F 2204/04	1	Heating	D06F 33/30, D06F 33/36, D06F 33/38, D06F 33/43, D06F 33/44, D06F 33/46, D06F 33/47, D06F 33/48,

CPC NOTICE OF CHANGES 808

DATE: FEBRUARY 1, 2020

PROJECT RP0608

<u>Type*</u>	<u>Symbol</u>	<u>Indent Level Number of dots (e.g. 0, 1, 2)</u>	<u>Title</u> <u>“CPC only” text should normally be enclosed in {curly brackets}**</u>	<u>Transferred to#</u>
				D06F 33/50, D06F 33/52, D06F 33/54, D06F 33/56, D06F 33/57, D06F 33/58, D06F 33/60, D06F 33/62, D06F 33/63, D06F 33/64, D06F 33/65, D06F 33/68, D06F 33/69, D06F 33/70, D06F 33/72, D06F 33/74, D06F 33/76, D06F 34/24, D06F 37/42, D06F 2105/10, D06F 2105/28
F	D06F 2204/06	1	Mechanical variables, e.g. drum rotation	D06F 33/30, D06F 33/36, D06F 33/38, D06F 33/40, D06F 33/43, D06F 33/44, D06F 33/46, D06F 33/47, D06F 33/48, D06F 33/50, D06F 33/52, D06F 33/54, D06F 33/56, D06F 33/57, D06F 33/58, D06F 33/60, D06F 33/62, D06F 33/63, D06F 33/64, D06F 33/65, D06F 33/68, D06F 33/69, D06F 33/70, D06F 33/72, D06F 33/74, D06F 33/76, D06F 37/42, D06F 2105/46
F	D06F 2204/065	2	having speed control arrangement	D06F 33/30, D06F 33/36, D06F 33/38, D06F 33/40, D06F 33/43, D06F 33/44, D06F 33/46, D06F 33/47, D06F 33/48, D06F 33/50, D06F 33/52, D06F 33/54, D06F 33/56, D06F 33/57, D06F 33/58, D06F 33/60, D06F 33/62, D06F 33/63, D06F 33/64, D06F 33/65, D06F 33/68, D06F 33/69, D06F 33/70, D06F 33/72, D06F 33/74, D06F 33/76, D06F 37/42, D06F 2105/48
F	D06F 2204/08	1	Liquid supply, circulation or discharge	D06F 33/30, D06F 33/36, D06F 33/38, D06F 33/43, D06F 33/44, D06F 33/46, D06F 33/47, D06F 33/48, D06F 33/50, D06F 33/52, D06F 33/54, D06F 33/56, D06F 33/57, D06F 33/58,

CPC NOTICE OF CHANGES 808

DATE: FEBRUARY 1, 2020

PROJECT RP0608

<u>Type*</u>	<u>Symbol</u>	<u>Indent Level Number of dots (e.g. 0, 1, 2)</u>	<u>Title</u> <u>“CPC only” text should normally be enclosed in {curly brackets}**</u>	<u>Transferred to#</u>
				D06F 33/60, D06F 33/62, D06F 33/63, D06F 33/64, D06F 33/65, D06F 33/68, D06F 33/69, D06F 33/70, D06F 33/72, D06F 33/74, D06F 33/76, D06F 37/42, D06F 2105/02, D06F 2105/06, D06F 2105/08
F	D06F 2204/082	2	Circulating	D06F 33/30, D06F 33/36, D06F 33/38, D06F 33/43, D06F 33/44, D06F 33/46, D06F 33/47, D06F 33/48, D06F 33/50, D06F 33/52, D06F 33/54, D06F 33/56, D06F 33/57, D06F 33/58, D06F 33/60, D06F 33/62, D06F 33/63, D06F 33/64, D06F 33/65, D06F 33/68, D06F 33/69, D06F 33/70, D06F 33/72, D06F 33/74, D06F 33/76, D06F 37/42, D06F 2105/06
F	D06F 2204/084	2	Draining	D06F 33/30, D06F 33/36, D06F 33/38, D06F 33/42, D06F 33/43, D06F 33/44, D06F 33/46, D06F 33/47, D06F 33/48, D06F 33/50, D06F 33/52, D06F 33/54, D06F 33/56, D06F 33/57, D06F 33/58, D06F 33/60, D06F 33/62, D06F 33/63, D06F 33/64, D06F 33/65, D06F 33/68, D06F 33/69, D06F 33/70, D06F 33/72, D06F 33/74, D06F 33/76, D06F 37/42, D06F 2105/08
F	D06F 2204/086	2	Water supply	D06F 33/30, D06F 33/34, D06F 33/36, D06F 33/38, D06F 33/43, D06F 33/44, D06F 33/46, D06F 33/47, D06F 33/48, D06F 33/50, D06F 33/52, D06F 33/54, D06F 33/56, D06F 33/57, D06F 33/58, D06F 33/60, D06F 33/62, D06F 33/63, D06F 33/64, D06F 33/65,

CPC NOTICE OF CHANGES 808

DATE: FEBRUARY 1, 2020

PROJECT RP0608

<u>Type*</u>	<u>Symbol</u>	<u>Indent Level Number of dots (e.g. 0, 1, 2)</u>	<u>Title</u> <u>“CPC only” text should normally be enclosed in {curly brackets}**</u>	<u>Transferred to#</u>
				D06F 33/68, D06F 33/69, D06F 33/70, D06F 33/72, D06F 33/74, D06F 33/76, D06F 37/42, D06F 2105/02
F	D06F 2204/088	3	with cold and hot water	D06F 33/30, D06F 33/34, D06F 33/36, D06F 33/38, D06F 33/43, D06F 33/44, D06F 33/46, D06F 33/47, D06F 33/48, D06F 33/50, D06F 33/52, D06F 33/54, D06F 33/56, D06F 33/57, D06F 33/58, D06F 33/60, D06F 33/62, D06F 33/63, D06F 33/64, D06F 33/65, D06F 33/68, D06F 33/69, D06F 33/70, D06F 33/72, D06F 33/74, D06F 33/76, D06F 37/42, D06F 2105/04
F	D06F 2204/10	1	Other output	D06F 33/30, D06F 33/36, D06F 33/38, D06F 33/43, D06F 33/44, D06F 33/46, D06F 33/47, D06F 33/48, D06F 33/50, D06F 33/52, D06F 33/54, D06F 33/56, D06F 33/57, D06F 33/58, D06F 33/60, D06F 33/62, D06F 33/63, D06F 33/64, D06F 33/65, D06F 33/68, D06F 33/69, D06F 33/70, D06F 33/72, D06F 33/74, D06F 33/76, D06F 34/04, D06F 34/05, D06F 37/42, D06F 2103/66, D06F 2105/00, D06F 2105/12, D06F 2105/50, D06F 2105/60, D06F 2105/62
F	D06F 2210/00	0	Interfaces, e.g. connections between different parts of the general control system	D06F 33/30, D06F 33/50, D06F 33/52, D06F 33/54, D06F 33/56, D06F 33/57, D06F 33/58, D06F 33/60, D06F 33/62, D06F 33/63, D06F 33/64, D06F 33/65, D06F 33/68, D06F 33/69, D06F 33/70, D06F 33/72, D06F 33/74, D06F 34/04, D06F 34/05, D06F 37/42, D06F 2105/58

CPC NOTICE OF CHANGES 808

DATE: FEBRUARY 1, 2020

PROJECT RP0608

<u>Type*</u>	<u>Symbol</u>	<u>Indent Level Number of dots (e.g. 0, 1, 2)</u>	<u>Title</u> <u>“CPC only” text should normally be enclosed in {curly brackets}**</u>	<u>Transferred to#</u>
F	D06F 2212/00	0	Programme or timing arrangements	D06F 33/30, D06F 33/44, D06F 33/50, D06F 33/52, D06F 33/54, D06F 33/56, D06F 33/57, D06F 33/58, D06F 33/60, D06F 33/62, D06F 33/63, D06F 33/64, D06F 33/65, D06F 33/68, D06F 33/69, D06F 33/70, D06F 33/72, D06F 33/74, D06F 33/76, D06F 34/06, D06F 37/42, D06F 2103/38, D06F 2105/56
F	D06F 2212/02	1	Electronic arrangements	D06F 33/30, D06F 33/44, D06F 33/50, D06F 33/52, D06F 33/54, D06F 33/56, D06F 33/57, D06F 33/58, D06F 33/60, D06F 33/62, D06F 33/63, D06F 33/64, D06F 33/65, D06F 33/68, D06F 33/69, D06F 33/70, D06F 33/72, D06F 33/74, D06F 33/76, D06F 34/06, D06F 37/42, D06F 2103/38, D06F 2105/56
F	D06F 2212/04	1	Hybrid arrangements	D06F 33/30, D06F 33/44, D06F 33/50, D06F 33/52, D06F 33/54, D06F 33/56, D06F 33/57, D06F 33/58, D06F 33/60, D06F 33/62, D06F 33/63, D06F 33/64, D06F 33/65, D06F 33/68, D06F 33/69, D06F 33/70, D06F 33/72, D06F 33/74, D06F 33/76, D06F 34/06, D06F 37/42, D06F 2103/38
F	D06F 2212/06	1	Control of the programmer in the event of stopping of the washing process, e.g. when opening the door or a current failure	D06F 33/30, D06F 33/44, D06F 33/50, D06F 33/52, D06F 33/54, D06F 33/56, D06F 33/57, D06F 33/58, D06F 33/60, D06F 33/62, D06F 33/63, D06F 33/64, D06F 33/65, D06F 33/68, D06F 33/69, D06F 33/70, D06F 33/72, D06F 33/74, D06F 33/76, D06F 34/06, D06F 37/42, D06F 2103/38, D06F 2105/50, D06F 2105/62

CPC NOTICE OF CHANGES 808

DATE: FEBRUARY 1, 2020

PROJECT RP0608

<u>Type*</u>	<u>Symbol</u>	<u>Indent Level Number of dots (e.g. 0, 1, 2)</u>	<u>Title</u> <u>“CPC only” text should normally be enclosed in {curly brackets}**</u>	<u>Transferred to#</u>
F	D06F 2214/00	0	Manual setting	D06F 33/30, D06F 33/50, D06F 33/52, D06F 33/54, D06F 33/56, D06F 33/57, D06F 33/58, D06F 33/60, D06F 33/62, D06F 33/63, D06F 33/64, D06F 33/65, D06F 33/68, D06F 33/69, D06F 33/70, D06F 33/72, D06F 33/74, D06F 33/76, D06F 37/42, D06F 2101/00, D06F 2101/02, D06F 2101/04, D06F 2101/06, D06F 2101/10, D06F 2101/12, D06F 2101/14, D06F 2101/16, D06F 2101/18, D06F 2101/20, D06F 2105/54
F	D06F 2216/00	0	Display arrangements	D06F 33/30, D06F 33/50, D06F 33/52, D06F 33/54, D06F 33/56, D06F 33/57, D06F 33/58, D06F 33/60, D06F 33/62, D06F 33/63, D06F 33/64, D06F 33/65, D06F 33/68, D06F 33/69, D06F 33/70, D06F 33/72, D06F 33/74, D06F 33/76, D06F 34/04, D06F 34/05, D06F 37/42, D06F 2105/54, D06F 2105/58
F	D06F 2220/00	0	Time, e.g. real time to perform one or more operations used to influence one or more of the subsequent operations	D06F 33/30, D06F 33/44, D06F 33/48, D06F 33/50, D06F 33/52, D06F 33/54, D06F 33/56, D06F 33/57, D06F 33/58, D06F 33/60, D06F 33/62, D06F 33/63, D06F 33/64, D06F 33/65, D06F 33/68, D06F 33/69, D06F 33/70, D06F 33/72, D06F 33/74, D06F 33/76, D06F 34/06, D06F 37/42, D06F 2103/38, D06F 2105/56
F	D06F 2222/00	0	Unbalance arrangements	D06F 33/30, D06F 33/50, D06F 33/52, D06F 33/54, D06F 33/56, D06F 33/57, D06F 33/58, D06F 33/60, D06F 33/62, D06F 33/63, D06F 33/64, D06F 33/65, D06F 33/68, D06F 33/69,

CPC NOTICE OF CHANGES 808

DATE: FEBRUARY 1, 2020

PROJECT RP0608

<u>Type*</u>	<u>Symbol</u>	<u>Indent Level Number of dots (e.g. 0, 1, 2)</u>	<u>Title</u> <u>“CPC only” text should normally be enclosed in {curly brackets}**</u>	<u>Transferred to#</u>
				D06F 33/70, D06F 33/72, D06F 33/74, D06F 33/76, D06F 34/16, D06F 37/42, D06F 2103/26
F	D06F 2224/00	0	Safety arrangement concerning the opening or closing of the door	D06F 33/30, D06F 33/47, D06F 33/50, D06F 33/52, D06F 33/54, D06F 33/56, D06F 33/57, D06F 33/58, D06F 33/60, D06F 33/62, D06F 33/63, D06F 33/64, D06F 33/65, D06F 33/68, D06F 33/69, D06F 33/70, D06F 33/72, D06F 33/74, D06F 33/76, D06F 37/42, D06F 2103/40, D06F 2105/44, D06F 2105/58, D06F 2105/60
F	D06F 2226/00	0	Liquid or energy recovery arrangements	D06F 33/30, D06F 33/46, D06F 33/50, D06F 33/52, D06F 33/54, D06F 33/56, D06F 33/57, D06F 33/58, D06F 33/60, D06F 33/62, D06F 33/63, D06F 33/64, D06F 33/65, D06F 33/68, D06F 33/69, D06F 33/70, D06F 33/72, D06F 33/74, D06F 33/76, D06F 34/24, D06F 37/42, D06F 2103/50, D06F 2105/26
D	D06F 2232/00	0	Processes performed on the laundry, e.g. washing	<Administrative transfer to D06F35/005>
D	D06F 2232/02	1	Biological washing	<Administrative transfer to D06F35/00>
D	D06F 2232/04	1	Wetting	<Administrative transfer to D06F35/006>
D	D06F 2232/06	1	Rinsing	<Administrative transfer to D06F35/006>
D	D06F 2232/08	1	Spinning	<Administrative transfer to D06F35/007>
D	D06F 2232/10	1	Drying with hot air in washing machines	<Administrative transfer to D06F25/00>
D	D06F 2700/00	0	Driving arrangements for washing machines having receptacles serving solely for washing and not for centrifugally draining	<Administrative transfer to D06F21/00 ADD and D06F37/30 INV simultaneously>

CPC NOTICE OF CHANGES 808

DATE: FEBRUARY 1, 2020

PROJECT RP0608

<u>Type*</u>	<u>Symbol</u>	<u>Indent Level Number of dots (e.g. 0, 1, 2)</u>	<u>Title</u> <u>“CPC only” text should normally be enclosed in {curly brackets}**</u>	<u>Transferred to#</u>
D	D06F 2700/04	1	Rotating the receptacle with more than one speed	<Administrative transfer to D06F21/00 ADD and D06F37/36 INV simultaneously>
D	D06F 2700/05	1	Rotating the receptacle with an alternating movement	<Administrative transfer to D06F21/00 ADD and D06F37/40 INV simultaneously>
D	D06F 2700/052	2	in which a driven shaft rotates and also undergoes another movement	<Administrative transfer to D06F21/00 ADD and D06F37/30 INV simultaneously>
D	D06F 2700/055	2	by changing between two transmissions with elements rolling on each other	<Administrative transfer to D06F21/00 ADD and D06F37/30 INV simultaneously>
D	D06F 2700/057	2	Other transmission devices for rotating the receptacle solely with an alternating movement	<Administrative transfer to D06F21/00 ADD and D06F37/38 INV simultaneously>

*N = new entries where reclassification into entries is involved; C = entries with modified file scope where reclassification of documents from the entries is involved; Q = new entries which are firstly populated with documents via administrative transfers from deleted (D) entries. Afterwards, the transferred documents into the Q entry will either stay or be moved to more appropriate entries, as determined by intellectual reclassification; T = existing entries with enlarged file scope, which receive documents from C or D entries, e.g. when a limiting reference is removed from the entry title; M = entries with no change to the file scope (no reclassification); D = deleted entries; F = frozen entries will be deleted once reclassification of documents from the entries is completed; U = entries that are unchanged.

NOTES:

- **No {curly brackets} are used for titles in CPC only subclasses, e.g. C12Y, A23Y; 2000 series symbol titles of groups found at the end of schemes (orthogonal codes); or the Y section titles. The {curly brackets} are used for 2000 series symbol titles found interspersed throughout the main trunk schemes (breakdown codes).
- U groups: it is obligatory to display the required “anchor” symbol (U group), i.e. the entry immediately preceding a new group or an array of new groups to be created (in case new groups are not clearly subgroups of C-type groups). Always include the symbol, indent level and title of the U group in the table above.
- All entry types should be included in the scheme changes table above for better understanding of the overall scheme change picture. Symbol, indent level, and title are required for all types.
- “Transferred to” column must be completed for all C, D, F, and Q type entries. F groups will be deleted once reclassification is completed.
- When multiple symbols are included in the “Transferred to” column, avoid using ranges of symbols in order to be as precise as possible.
- For administrative transfer of documents, the following text should be used: “< administrative transfer to XX>”, “<administrative transfer to XX and YY simultaneously>”, or “<administrative transfer to XX, YY ...and ZZ simultaneously>” when administrative transfer of the same documents is to more than one place.
- Administrative transfer to main trunk groups is assumed to be the source allocation type, unless otherwise indicated.
- Administrative transfer to 2000/Y series groups is assumed to be “additional information”.
- If needed, instructions for allocation type should be indicated within the angle brackets using the abbreviations “ADD” or “INV”: <administrative transfer to XX ADD> , <administrative transfer to XX INV>, or < administrative transfer to XX ADD, YY INV, ... and ZZ ADD simultaneously>.
- In certain situations, the “D” entries of 2000-series or Y-series groups may not require a destination (“Transferred to”) symbol, however it is required to specify “<no transfer>” in the “Transferred to” column for such cases.
- For finalisation projects, the deleted “F” symbols should have <no transfer> in the “Transferred to” column.
- For more details about the types of scheme change, see CPC Guide.

CPC NOTICE OF CHANGES 808

DATE: FEBRUARY 1, 2020

PROJECT RP0608

B. New, Modified or Deleted Warning(s)

SUBCLASS D06F - LAUNDERING, DRYING, IRONING, PRESSING OR FOLDING TEXTILE ARTICLES
 (apparatus for blocking, pressing, steaming, or stretching hats A42C; treating textile materials by liquids, gases or vapours D06B; chemical matters, see D06L, D06M)

<u>Type*</u>	<u>Location</u>	<u>Old Warning</u>	<u>New/Modified Warning</u>
N	D06F 18/00		Group D06F 18/00 is impacted by reclassification into groups D06F31/00, D06F31/005, D06F33/00 - D06F33/76, D06F 34/00 - D06F 34/34, D06F 37/42, D06F 2101/00 - D06F 2101/20, D06F 2103/02 - D06F 2103/04, D06F 2103/06, D06F 2103/08, D06F 2103/20, D06F 2103/22, D06F 2103/68, D06F 2103/70, D06F 2105/50, D06F 2105/52, D06F 2105/54, D06F 2105/56, D06F 2105/58, D06F 2105/60, and D06F 2105/62. All groups listed in this Warning should be considered in order to perform a complete search.
N	D06F 19/00		Group D06F 19/00 is impacted by reclassification into group D06F 2103/66. Groups D06F 19/00 and D06F 2103/66 should be considered in order to perform a complete search.
N	D06F 25/00		Group D06F 25/00 is impacted by reclassification into groups D06F 34/00 - D06F 34/34, D06F 2101/00 - D06F 2101/20, D06F 2103/00, D06F 2103/02, D06F 2103/04, D06F 2103/06, D06F 2103/08, D06F 2103/20, D06F 2103/22, D06F 2103/68, D06F 2103/70, D06F 2105/50, D06F 2105/52, D06F 2105/54, D06F 2105/56, D06F 2105/58, D06F 2105/60, and D06F 2105/62. All groups listed in this Warning should be considered in order to perform a complete search.
N	D06F 31/00		Groups D06F 31/00 - D06F 31/005 are incomplete pending reclassification of documents from groups D06F 18/00 and D06F 39/00. Groups D06F 18/00, D06F 39/00, and D06F 31/00 should be considered in order to perform a complete search.

CPC NOTICE OF CHANGES 808

DATE: FEBRUARY 1, 2020

PROJECT RP0608

<u>Type*</u>	<u>Location</u>	<u>Old Warning</u>	<u>New/Modified Warning</u>
N	D06F 33/00		Group D06F 33/00 is incomplete pending reclassification of documents from groups D06F 18/00 and D06F 39/00. Group D06F 33/00 is also impacted by reclassification into groups D06F 33/30 - D06F 33/76, D06F 34/00 - D06F 34/34, D06F 37/42, D06F 58/32 - D06F 58/52, D06F 2101/00 - D06F 2103/70, and D06F 2105/00 - D06F 2105/62. All groups listed in this Warning should be considered in order to perform a complete search.
N	D06F 33/04		Group D06F 33/04 – D06F33/10 are incomplete pending reclassification of documents from groups D06F 18/00 and D06F 39/00. Groups D06F 18/00, D06F 39/00, and D06F 33/04 should be considered in order to perform a complete search.
N	D06F 33/30		Group D06F 33/30 is incomplete pending reclassification of documents from groups D06F 18/00, D06F 33/00, D06F 39/00, D06F 2202/00 - D06F 2202/12, D06F 2204/00 - D06F 2204/10, D06F 2210/00, D06F 2212/00 - D06F 2212/06, D06F 2214/00, D06F 2216/00, D06F 2220/00, D06F 2222/00, D06F 2224/00, and D06F 2226/00. All groups listed in this Warning should be considered in order to perform a complete search.
N	D06F 33/32		Group D06F 33/32 is incomplete pending reclassification of documents from groups D06F 18/00, D06F 33/00, D06F 39/00, and D06F 2202/10. All groups listed in this Warning should be considered in order to perform a complete search.
N	D06F 33/34		Group D06F 33/34 is incomplete pending reclassification of documents from groups D06F 18/00, D06F 33/00, D06F 39/00, D06F 2202/10, D06F 2204/086, and D06F 2204/088. All groups listed in this Warning should be considered in order to perform a complete search.
N	D06F 33/36		Group D06F 33/36 is incomplete pending reclassification of documents from groups D06F 18/00, D06F 33/00, D06F 35/005, D06F 35/006, D06F 39/00, D06F 2202/10, D06F 2202/12, and D06F 2204/00 - D06F 2204/10. All groups listed in this Warning should be considered in order to perform a complete search.

CPC NOTICE OF CHANGES 808

DATE: FEBRUARY 1, 2020

PROJECT RP0608

<u>Type*</u>	<u>Location</u>	<u>Old Warning</u>	<u>New/Modified Warning</u>
N	D06F 33/37		Group D06F 33/37 is incomplete pending reclassification of documents from groups D06F 18/00, D06F 33/00, D06F 39/00, D06F 39/02, D06F 39/022, D06F 39/024, D06F 39/026, D06F 39/028, D06F 2202/10, and D06F 2204/02. All groups listed in this Warning should be considered in order to perform a complete search.
N	D06F 33/38		Group D06F 33/38 is incomplete pending reclassification of documents from groups D06F 18/00, D06F 33/00, D06F 35/005, D06F 35/006, D06F 39/00, D06F 2202/10, and D06F 2204/00 - D06F 2204/10. All groups listed in this Warning should be considered in order to perform a complete search.
N	D06F 33/40		Group D06F 33/40 is incomplete pending reclassification of documents from groups D06F 18/00, D06F 33/00, D06F 35/007, D06F 39/00, D06F 2202/10, D06F 2204/06, and D06F 2204/065. All groups listed in this Warning should be considered in order to perform a complete search.
N	D06F 33/42		Group D06F 33/42 is incomplete pending reclassification of documents from groups D06F 18/00, D06F 33/00, D06F 39/00, D06F 39/08, D06F 39/083, D06F 39/085, D06F 2202/10, and D06F 2204/084. All groups listed in this Warning should be considered in order to perform a complete search.
N	D06F 33/43		Group D06F 33/43 is incomplete pending reclassification of documents from groups D06F 18/00, D06F 33/00, D06F 35/008, D06F 39/00, D06F 2202/10, and D06F 2204/00 - D06F 2204/10. All groups listed in this Warning should be considered in order to perform a complete search.
N	D06F 33/44		Group D06F 33/44 is incomplete pending reclassification of documents from groups D06F 18/00, D06F 33/00, D06F 39/00, D06F 2202/10, D06F 2204/00, D06F 2204/10, D06F 2212/00 - D06F 2212/06, and D06F 2220/00. All groups listed in this Warning should be considered in order to perform a complete search.

CPC NOTICE OF CHANGES 808

DATE: FEBRUARY 1, 2020

PROJECT RP0608

<u>Type*</u>	<u>Location</u>	<u>Old Warning</u>	<u>New/Modified Warning</u>
N	D06F 33/46		Group D06F 33/46 is incomplete pending reclassification of documents from groups D06F 18/00, D06F 33/00, D06F 39/00, D06F 39/006, D06F 2202/10, D06F 2204/00 - D06F 2204/10, and D06F 2226/00. All groups listed in this Warning should be considered in order to perform a complete search.
N	D06F 33/47		Group D06F 33/47 is incomplete pending reclassification of documents from groups D06F 18/00, D06F 33/00, D06F 39/00, D06F 39/08 - D06F 39/088, D06F 39/14, D06F 2202/10, D06F 2204/00 - D06F 2204/02, D06F 2204/04, D06F 2204/10, and D06F 2224/00. All groups listed in this Warning should be considered in order to perform a complete search.
N	D06F 33/48		Group D06F 33/48 is incomplete pending reclassification of documents from groups D06F 18/00, D06F 33/00, D06F 37/203, D06F 37/22, D06F 37/225, D06F 37/24, D06F 37/245, D06F 39/00, D06F 2202/10, D06F 2204/00 - D06F 2204/10, and D06F 2220/00. All groups listed in this Warning should be considered in order to perform a complete search.
N	D06F 33/50		Group D06F 33/50 - D06F 33/56 are incomplete pending reclassification of documents from groups D06F 18/00, D06F 33/00, D06F 39/00, D06F 58/00, D06F 58/02, D06F 58/203, D06F 58/30, D06F 2202/00 - D06F 2202/12, D06F 2204/00 - D06F 2204/10, D06F 2210/00, D06F 2212/00 - D06F 2212/06, D06F 2214/00, D06F 2216/00, D06F 2220/00, D06F 2222/00, D06F 2224/00, and D06F 2226/00. All groups listed in this Warning should be considered in order to perform a complete search.
N	D06F 33/57		Group D06F 33/57 is incomplete pending reclassification of documents from groups D06F 18/00, D06F 33/00, D06F 39/00, D06F 39/02, D06F 39/022, D06F 39/024, D06F 39/026, D06F 39/028, D06F 58/00, D06F 58/02, D06F 58/203, D06F 58/30, D06F 2202/00 - D06F 2202/12, D06F 2204/00 - D06F 2204/10, D06F 2210/00, D06F 2212/00 - D06F 2212/06, D06F 2214/00,

CPC NOTICE OF CHANGES 808

DATE: FEBRUARY 1, 2020

PROJECT RP0608

<u>Type*</u>	<u>Location</u>	<u>Old Warning</u>	<u>New/Modified Warning</u>
			D06F 2216/00, D06F 2220/00, D06F 2222/00, D06F 2224/00, and D06F 2226/00. All groups listed in this Warning should be considered in order to perform a complete search.
N	D06F 33/58		Group D06F 33/58 is incomplete pending reclassification of documents from groups D06F 18/00, D06F 33/00, D06F 35/005, D06F 35/006, D06F 39/00, D06F 58/00, D06F 58/02, D06F 58/203, D06F 58/30, D06F 2202/00 - D06F 2202/12, D06F 2204/00 - D06F 2204/10, D06F 2210/00, D06F 2212/00, D06F 2212/02, D06F 2212/04, D06F 2212/06, D06F 2214/00, D06F 2216/00, D06F 2220/00, D06F 2222/00, D06F 2224/00, and D06F 2226/00. All groups listed in this Warning should be considered in order to perform a complete search.
N	D06F 33/60		Group D06F 33/60 is incomplete pending reclassification of documents from groups D06F 18/00, D06F 33/00, D06F 35/007, D06F 39/00, D06F 58/00, D06F 58/02, D06F 58/203, D06F 58/30, D06F 2202/00 - D06F 2202/12, D06F 2204/00 - D06F 2204/10, D06F 2210/00, D06F 2212/00, D06F 2212/02, D06F 2212/04, D06F 2212/06, D06F 2214/00, D06F 2216/00, D06F 2220/00, D06F 2222/00, D06F 2224/00, and D06F 2226/00. All groups listed in this Warning should be considered in order to perform a complete search.
N	D06F 33/62		Group D06F 33/62 is incomplete pending reclassification of documents from groups D06F 18/00, D06F 33/00, D06F 39/00, D06F 39/08, D06F 39/083, D06F 39/085, D06F 58/00, D06F 58/02, D06F 58/203, D06F 58/30, D06F 2202/00 - D06F 2202/12, D06F 2204/00 - D06F 2204/10, D06F 2210/00, D06F 2212/00 - D06F 2212/06, D06F 2214/00, D06F 2216/00, D06F 2220/00, D06F 2222/00, D06F 2224/00, and D06F 2226/00. All groups listed in this Warning should be considered in order to perform a complete search.

CPC NOTICE OF CHANGES 808

DATE: FEBRUARY 1, 2020

PROJECT RP0608

<u>Type*</u>	<u>Location</u>	<u>Old Warning</u>	<u>New/Modified Warning</u>
N	D06F 33/63		Groups D06F 33/63 - D06F 33/64 are incomplete pending reclassification of documents from groups D06F 18/00, D06F 33/00, D06F 39/00, D06F 58/00, D06F 58/02, D06F 58/20, D06F 58/203, D06F 58/30, D06F 2202/00 - D06F 2202/12, D06F 2204/00 - D06F 2204/10, D06F 2210/00, D06F 2212/00 - D06F 2212/06, D06F 2214/00, D06F 2216/00, D06F 2220/00, D06F 2222/00, D06F 2224/00, and D06F 2226/00. All groups listed in this Warning should be considered in order to perform a complete search.
N	D06F 33/65		Group D06F 33/65 is incomplete pending reclassification of documents from groups D06F 18/00, D06F 33/00, D06F 39/00, D06F 39/008, D06F 58/00, D06F 58/02, D06F 58/203, D06F 58/30, D06F 2202/00 - D06F 2202/12, D06F 2204/00 - D06F 2204/10, D06F 2210/00, D06F 2212/00 - D06F 2212/06, D06F 2214/00, D06F 2216/00, D06F 2220/00, D06F 2222/00, D06F 2224/00, and D06F 2226/00. All groups listed in this Warning should be considered in order to perform a complete search.
N	D06F 33/68		Group D06F 33/68 is incomplete pending reclassification of documents from groups D06F 18/00, D06F 33/00, D06F 39/00, D06F 39/008, D06F 58/00, D06F 58/02, D06F 58/203, D06F 58/30, D06F 2202/00 - D06F 2202/12, D06F 2204/00 - D06F 2204/10, D06F 2210/00, D06F 2212/00 - D06F 2212/06, D06F 2214/00, D06F 2216/00, D06F 2220/00, D06F 2222/00, D06F 2224/00, and D06F 2226/00. All groups listed in this Warning should be considered in order to perform a complete search.
N	D06F 33/69		Group D06F 33/69 is incomplete pending reclassification of documents from groups D06F 18/00, D06F 33/00, D06F 35/008, D06F 39/00, D06F 58/00, D06F 58/02, D06F 58/203, D06F 58/30, D06F 2202/00 - D06F 2202/12, D06F 2204/00 - D06F 2204/10, D06F 2210/00, D06F 2212/00 - D06F 2212/06, D06F 2214/00, D06F 2216/00, D06F 2220/00, D06F 2222/00,

CPC NOTICE OF CHANGES 808

DATE: FEBRUARY 1, 2020

PROJECT RP0608

<u>Type*</u>	<u>Location</u>	<u>Old Warning</u>	<u>New/Modified Warning</u>
			D06F 2224/00, and D06F 2226/00. All groups listed in this Warning should be considered in order to perform a complete search.
N	D06F 33/70		Group D06F 33/70 is incomplete pending reclassification of documents from groups D06F 18/00, D06F 33/00, D06F 35/008, D06F 39/00, D06F 58/00, D06F 58/02, D06F 58/203, D06F 58/30, D06F 2202/00 - D06F 2202/12, D06F 2204/00 - D06F 2204/10, D06F 2210/00, D06F 2212/00 - D06F 2212/06, D06F 2214/00, D06F 2216/00, D06F 2220/00, D06F 2222/00, D06F 2224/00, and D06F 2226/00. All groups listed in this Warning should be considered in order to perform a complete search.
N	D06F 33/72		Group D06F 33/72 is incomplete pending reclassification of documents from groups D06F 18/00, D06F 33/00, D06F 39/00, D06F 39/006, D06F 58/00, D06F 58/02, D06F 58/203, D06F 58/30, D06F 2202/00 - D06F 2202/12, D06F 2204/00 - D06F 2204/10, D06F 2210/00, D06F 2212/00 - D06F 2212/06, D06F 2214/00, D06F 2216/00, D06F 2220/00, D06F 2222/00, D06F 2224/00, and D06F 2226/00. All groups listed in this Warning should be considered in order to perform a complete search.
N	D06F 33/74		Group D06F 33/74 is incomplete pending reclassification of documents from groups D06F 18/00, D06F 33/00, D06F 39/00, D06F 39/08, D06F 39/081, D06F 39/082, D06F 39/083, D06F 39/085, D06F 39/086, D06F 39/087, D06F 39/088, D06F 39/14, D06F 58/00, D06F 58/02, D06F 58/203, D06F 58/30, D06F 2202/00 - D06F 2202/12, D06F 2204/00 - D06F 2204/10, D06F 2210/00, D06F 2212/00 - D06F 2212/06, D06F 2214/00, D06F 2216/00, D06F 2220/00, D06F 2222/00, D06F 2224/00, and D06F 2226/00. All groups listed in this Warning should be considered in order to perform a complete search.

CPC NOTICE OF CHANGES 808

DATE: FEBRUARY 1, 2020

PROJECT RP0608

<u>Type*</u>	<u>Location</u>	<u>Old Warning</u>	<u>New/Modified Warning</u>
N	D06F 33/76		Group D06F 33/76 is incomplete pending reclassification of documents from groups D06F 18/00, D06F 33/00, D06F 37/203, D06F 37/22, D06F 37/225, D06F 37/24, D06F 37/245, D06F 39/00, D06F 58/00, D06F 58/02, D06F 58/203, D06F 58/30, D06F 2202/00 - D06F 2202/12, D06F 2204/00 - D06F 2204/10, D06F 2210/00, D06F 2212/00 - D06F 2212/06, D06F 2214/00, D06F 2216/00, D06F 2220/00, D06F 2222/00, D06F 2224/00, and D06F 2226/00. All groups listed in this Warning should be considered in order to perform a complete search.
N	D06F 34/00		Group D06F 34/00 is incomplete pending reclassification of documents from groups D06F 18/00, D06F 25/00, D06F 33/00, D06F 35/00, D06F 35/001, D06F 35/002, D06F 35/003, D06F 35/004, D06F 35/005, D06F 35/006, D06F 35/007, D06F 35/008, D06F 37/00, D06F 39/00, D06F 58/00, D06F 58/02, D06F 58/04, D06F 58/203, D06F 58/30, D06F 2202/00, D06F 2202/12, and D06F 2204/00. All groups listed in this Warning should be considered in order to perform a complete search.
N	D06F 34/04		Groups D06F 34/04 - D06F 34/05 are incomplete pending reclassification of documents from groups D06F 18/00, D06F 25/00, D06F 33/00, D06F 35/00, D06F 35/001, D06F 35/002, D06F 35/003, D06F 35/004, D06F 35/005, D06F 35/006, D06F 35/007, D06F 35/008, D06F 37/00, D06F 39/00, D06F 58/00, D06F 58/02, D06F 58/04, D06F 58/203, D06F 58/30, D06F 2202/00, D06F 2202/12, and D06F 2204/00. All groups listed in this Warning should be considered in order to perform a complete search.
N	D06F 34/06		Group D06F 34/06 is incomplete pending reclassification of documents from groups D06F 18/00, D06F 25/00, D06F 33/00, D06F 35/00 - D06F 35/008, D06F 37/00, D06F 39/00, D06F 58/00, D06F 58/02, D06F 58/04, D06F 58/203, D06F 58/30, D06F 2202/00, D06F 2202/12, D06F 2204/00, D06F 2212/00 - D06F 2212/06, and D06F 2220/00. All groups listed in this Warning should be

CPC NOTICE OF CHANGES 808

DATE: FEBRUARY 1, 2020

PROJECT RP0608

<u>Type*</u>	<u>Location</u>	<u>Old Warning</u>	<u>New/Modified Warning</u>
			considered in order to perform a complete search.
N	D06F 34/08		Group D06F 34/08 is incomplete pending reclassification of documents from groups D06F 18/00, D06F 25/00, D06F 33/00, D06F 35/00, D06F 35/001, D06F 35/002, D06F 35/003, D06F 35/004, D06F 35/005, D06F 35/006, D06F 35/007, D06F 35/008, D06F 37/00, D06F 37/203, D06F 37/22, D06F 37/225, D06F 37/24, D06F 37/245, D06F 37/30, D06F 37/304, D06F 37/306, D06F 39/00, D06F 39/006, D06F 39/022, D06F 39/04, D06F 39/06, D06F 58/00, D06F 58/02, D06F 58/04, D06F 58/203, D06F 58/30, D06F 2202/00, D06F 2202/12, and D06F 2204/00. All groups listed in this Warning should be considered in order to perform a complete search.
N	D06F 34/10		Group D06F 34/10 is incomplete pending reclassification of documents from groups D06F 18/00, D06F 25/00, D06F 33/00, D06F 35/00, D06F 35/001, D06F 35/002, D06F 35/003, D06F 35/004, D06F 35/005, D06F 35/006, D06F 35/007, D06F 35/008, D06F 37/00, D06F 37/30, D06F 37/304, D06F 37/306, D06F 37/42, D06F 39/00, D06F 39/081, D06F 39/12, D06F 39/14, D06F 58/00, D06F 58/02, D06F 58/04, D06F 58/08, D06F 58/20, D06F 58/203, D06F 58/30, D06F 2202/00, D06F 2202/12, and D06F 2204/00. All groups listed in this Warning should be considered in order to perform a complete search.
N	D06F 34/14		Group D06F 34/14 is incomplete pending reclassification of documents from groups D06F 18/00, D06F 25/00, D06F 33/00, D06F 35/00, D06F 35/001, D06F 35/002, D06F 35/003, D06F 35/004, D06F 35/005, D06F 35/006, D06F 35/007, D06F 35/008, D06F 37/00, D06F 39/00, D06F 58/00, D06F 58/02, D06F 58/04, D06F 58/203, D06F 58/30, D06F 2202/00, D06F 2202/12, and D06F 2204/00. All groups listed in this Warning should be considered in order to perform a complete search.
N	D06F 34/16		Group D06F 34/16 is incomplete pending reclassification of documents from groups D06F 18/00, D06F 25/00, D06F 33/00, D06F 35/00, D06F 35/001, D06F 35/002, D06F 35/003, D06F 35/004, D06F 35/005, D06F 35/006, D06F 35/007, D06F 35/008,

CPC NOTICE OF CHANGES 808

DATE: FEBRUARY 1, 2020

PROJECT RP0608

<u>Type*</u>	<u>Location</u>	<u>Old Warning</u>	<u>New/Modified Warning</u>
			D06F 37/00, D06F 37/203, D06F 37/22, D06F 37/225, D06F 37/24, D06F 37/245, D06F 39/00, D06F 58/00, D06F 58/02, D06F 58/04, D06F 58/20, D06F 58/203, D06F 58/30, D06F 2202/00, D06F 2202/12, D06F 2204/00, and D06F 2222/00. All groups listed in this Warning should be considered in order to perform a complete search.
N	D06F 34/18		Group D06F 34/18 is incomplete pending reclassification of documents from groups D06F 18/00, D06F 25/00, D06F 33/00, D06F 35/00, D06F 35/001, D06F 35/002, D06F 35/003, D06F 35/004, D06F 35/005, D06F 35/006, D06F 35/007, D06F 35/008, D06F 37/00, D06F 39/00, D06F 58/00, D06F 58/02, D06F 58/04, D06F 58/20, D06F 58/203, D06F 58/30, D06F 2202/00, D06F 2202/12, and D06F 2204/00. Group D06F 34/18 is also impacted by reclassification into groups D06F 2103/02, D06F 2103/04, D06F 2103/06, and D06F 2103/08. All groups listed in this Warning should be considered in order to perform a complete search.
N	D06F 34/20		Group D06F 34/20 is incomplete pending reclassification of documents from groups D06F 18/00, D06F 25/00, D06F 33/00, D06F 35/00, D06F 35/001, D06F 35/002, D06F 35/003, D06F 35/004, D06F 35/005, D06F 35/006, D06F 35/007, D06F 35/008, D06F 37/00, D06F 37/10, D06F 37/18, D06F 37/28, D06F 37/302, D06F 37/42, D06F 39/00, D06F 39/12, D06F 39/125, D06F 39/14, D06F 58/00, D06F 58/02, D06F 58/04, D06F 58/20, D06F 58/203, D06F 58/30, D06F 2202/00, D06F 2202/12, and D06F 2204/00. All groups listed in this Warning should be considered in order to perform a complete search.
N	D06F 34/22		Group D06F 34/22 is incomplete pending reclassification of documents from groups D06F 18/00, D06F 25/00, D06F 33/00, D06F 35/00, D06F 35/001, D06F 35/002, D06F 35/003, D06F 35/004, D06F 35/005, D06F 35/006, D06F 35/007, D06F 35/008, D06F 37/00, D06F 39/00, D06F 58/00, D06F 58/02, D06F 58/04, D06F 58/203, D06F 58/30, D06F 2202/00, D06F 2202/12, and D06F 2204/00. Group D06F 34/22 is also impacted by reclassification into

CPC NOTICE OF CHANGES 808

DATE: FEBRUARY 1, 2020

PROJECT RP0608

<u>Type*</u>	<u>Location</u>	<u>Old Warning</u>	<u>New/Modified Warning</u>
			groups D06F 2103/20 and D06F 2103/22. All groups listed in this Warning should be considered in order to perform a complete search.
N	D06F 34/24		Group D06F 34/24 is incomplete pending reclassification of documents from groups D06F 18/00, D06F 25/00, D06F 33/00, D06F 35/00, D06F 35/001, D06F 35/002, D06F 35/003, D06F 35/004, D06F 35/005, D06F 35/006, D06F 35/007, D06F 35/008, D06F 37/00, D06F 39/00, D06F 39/006, D06F 39/04, D06F 39/045, D06F 58/00, D06F 58/02, D06F 58/04, D06F 58/203, D06F 58/30, D06F 2202/00, D06F 2202/04, D06F 2202/12, D06F 2204/00, D06F 2204/04, and D06F 2226/00. All groups listed in this Warning should be considered in order to perform a complete search.
N	D06F 34/26		Group D06F 34/26 is incomplete pending reclassification of documents from groups D06F 18/00, D06F 25/00, D06F 33/00, D06F 35/00, D06F 35/001, D06F 35/002, D06F 35/003, D06F 35/004, D06F 35/005, D06F 35/006, D06F 35/007, D06F 35/008, D06F 37/00, D06F 39/00, D06F 58/00, D06F 58/02, D06F 58/04, D06F 58/10, D06F 58/12, D06F 58/14, D06F 58/20, D06F 58/203, D06F 58/30, D06F 2202/00, D06F 2202/12, and D06F 2204/00. All groups listed in this Warning should be considered in order to perform a complete search.
N	D06F 34/28		Group D06F 34/28 is incomplete pending reclassification of documents from groups D06F 18/00, D06F 25/00, D06F 33/00, D06F 35/00 - D06F 35/008, D06F 37/00, D06F 39/00, D06F 58/00, D06F 58/02, D06F 58/04, D06F 58/20, D06F 58/203, D06F 58/30, D06F 2202/00, D06F 2202/12, and D06F 2204/00. Group D06F 34/28 is also impacted by reclassification into groups D06F 34/30, D06F 34/32, D06F 34/34, D06F 2101/00 - D06F 2101/20, D06F 2103/68, D06F 2103/70, D06F 2105/50 - D06F 2105/60, and D06F 2105/62. All groups listed in this Warning should be considered in order to perform a complete search.

CPC NOTICE OF CHANGES 808

DATE: FEBRUARY 1, 2020

PROJECT RP0608

<u>Type*</u>	<u>Location</u>	<u>Old Warning</u>	<u>New/Modified Warning</u>
N	D06F 34/30		Group D06F 34/30 - D06F 34/34 are incomplete pending reclassification of documents from groups D06F 18/00, D06F 25/00, D06F 33/00, D06F 34/28, D06F 35/00 - D06F 35/008, D06F 37/00, D06F 39/00, D06F 58/00, D06F 58/02, D06F 58/04, D06F 58/20, D06F 58/203, D06F 58/30, D06F 2202/00, D06F 2202/12, and D06F 2204/00. All groups listed in this Warning should be considered in order to perform a complete search.
N	D06F 35/00		Group D06F 35/00 is impacted by reclassification into groups D06F 34/00, D06F 34/04 - D06F 34/34, D06F 2101/00 - D06F 2101/20, D06F 2103/00 - D06F 2103/70, D06F 2105/50, and D06F 2105/52 - D06F 2105/62. All groups listed in this Warning should be considered in order to perform a complete search.
N	D06F 35/001		Group D06F 35/001 is impacted by reclassification into groups D06F 34/00, D06F 34/04 - D06F 34/34, D06F 2101/00 - D06F 2101/20, D06F 2103/00 - D06F 2103/70, D06F 2105/50, and D06F 2105/52 - D06F 2105/62. All groups listed in this Warning should be considered in order to perform a complete search.
N	D06F 35/002		Group D06F 35/002 is impacted by reclassification into groups D06F 34/00, D06F 34/04 - D06F 34/34, D06F 2101/00 - D06F 2101/20, D06F 2103/00 - D06F 2103/70, D06F 2105/50, and D06F 2105/52 - D06F 2105/62. All groups listed in this Warning should be considered in order to perform a complete search.
N	D06F 35/003		Group D06F 35/003 is impacted by reclassification into D06F 34/00, D06F 34/04 - D06F 34/34, D06F 2101/00 - D06F 2101/20, D06F 2103/00 - D06F 2103/70, D06F 2105/50, and D06F 2105/52 - D06F 2105/62. All groups listed in this Warning should be considered in order to perform a complete search.
N	D06F 35/004		Group D06F 35/004 is impacted by reclassification into groups D06F 34/00, D06F 34/04 - D06F 34/34, D06F 2101/00 - D06F 2101/20, D06F 2103/00 - D06F 2103/70, D06F 2105/50, and D06F 2105/52 - D06F 2105/62. All groups listed in this Warning should be considered in order to perform a complete search.

CPC NOTICE OF CHANGES 808

DATE: FEBRUARY 1, 2020

PROJECT RP0608

<u>Type*</u>	<u>Location</u>	<u>Old Warning</u>	<u>New/Modified Warning</u>
N	D06F 35/005		Group D06F 35/005 is impacted by reclassification into groups D06F 33/36, D06F 33/38, D06F 33/56, D06F 33/58, D06F 34/00, D06F 34/04 - D06F 34/34, D06F 2101/00 - D06F 2101/20, D06F 2103/00 - D06F 2103/70, D06F 2105/50, and D06F 2105/52 - D06F 2105/62. All groups listed in this Warning should be considered in order to perform a complete search.
N	D06F 35/006		Group D06F 35/006 is impacted by reclassification into groups D06F 33/36, D06F 33/38, D06F 33/56, D06F 33/58, D06F 34/00, D06F 34/04 - D06F 34/34, D06F 2101/00 - D06F 2101/20, D06F 2103/00 - D06F 2103/70, D06F 2105/50, and D06F 2105/52 - D06F 2105/62. All groups listed in this Warning should be considered in order to perform a complete search.
N	D06F 35/007		Group D06F 35/007 is impacted by reclassification into groups D06F 33/40, D06F 33/60, D06F 34/00, D06F 34/04 - D06F 34/34, D06F 2101/00 - D06F 2101/20, D06F 2103/00 - D06F 2103/70, D06F 2105/50, and D06F 2105/52 - D06F 2105/62. All groups listed in this Warning should be considered in order to perform a complete search.
N	D06F 35/008		Group D06F 35/008 is impacted by reclassification into groups D06F 33/43, D06F 33/69, D06F 34/00 - D06F 34/34, D06F 2101/00 - D06F 2101/20, D06F 2103/00 - D06F 2103/70, D06F 2105/50, and D06F 2105/52 - D06F 2105/62. All groups listed in this Warning should be considered in order to perform a complete search.
N	D06F 37/00		Group D06F 37/00 is impacted by reclassification into groups D06F 34/00 - D06F 34/34, D06F 2101/00 - D06F 2101/20, D06F 2103/00 - D06F 2103/70, D06F 2105/50, and D06F 2105/52 - D06F 2105/62. All groups listed in this Warning should be considered in order to perform a complete search.

CPC NOTICE OF CHANGES 808

DATE: FEBRUARY 1, 2020

PROJECT RP0608

<u>Type*</u>	<u>Location</u>	<u>Old Warning</u>	<u>New/Modified Warning</u>
N	D06F 37/10		Group D06F 37/10 is impacted by reclassification into groups D06F 34/20, D06F 2103/40, and D06F 2105/44. All groups listed in this Warning should be considered in order to perform a complete search.
N	D06F 37/18		Group D06F 37/18 is impacted by reclassification into groups D06F 34/20, D06F 2103/40, and D06F 2105/44. All groups listed in this Warning should be considered in order to perform a complete search.
N	D06F 37/203		Group D06F 37/203 is no longer used for the classification of documents as of February 1, 2020. The content of this group is being reclassified into groups D06F 33/48, D06F 33/76, D06F 34/08, D06F 34/16, D06F 2103/26, and D06F 2103/46. All groups listed in this Warning should be considered in order to perform a complete search.
N	D06F 37/22		Group D06F 37/22 is impacted by reclassification into groups D06F 33/48, D06F 33/76, D06F 34/08, and D06F 34/16. All groups listed in this Warning should be considered in order to perform a complete search.
N	D06F 37/225		Group D06F 37/225 is impacted by reclassification into groups D06F 33/48, D06F 33/76, D06F 34/08, and D06F 34/16. All groups listed in this Warning should be considered in order to perform a complete search.
N	D06F 37/24		Group D06F 37/24 is impacted by reclassification into groups D06F 33/48, D06F 33/76, D06F 34/08, and D06F 34/16. All groups listed in this Warning should be considered in order to perform a complete search.
N	D06F 37/245		Group D06F 37/245 is impacted by reclassification into groups D06F 33/48, D06F 33/76, D06F 34/08, and D06F 34/16. All groups listed in this Warning should be considered in order to perform a complete search.
N	D06F 37/28		Group D06F 37/28 is impacted by reclassification into group D06F 34/20. Groups D06F 37/28 and D06F 34/20 should be considered in order to perform a complete search.

CPC NOTICE OF CHANGES 808

DATE: FEBRUARY 1, 2020

PROJECT RP0608

<u>Type*</u>	<u>Location</u>	<u>Old Warning</u>	<u>New/Modified Warning</u>
N	D06F 37/30		Group D06F 37/30 is impacted by reclassification into groups D06F 34/08 and D06F 34/10. Groups D06F 37/30, D06F 34/08, and D06F 34/10 should be considered in order to perform a complete search.
N	D06F 37/302		Group D06F 37/302 is impacted by reclassification into groups D06F 34/20, D06F 2103/40, and D06F 2105/44. All groups listed in this Warning should be considered in order to perform a complete search.
N	D06F 37/304		Group D06F 37/304 is impacted by reclassification into groups D06F 34/08, D06F 34/10, D06F 2103/24, D06F 2103/46, D06F 2105/46, and D06F 2105/48. All groups listed in this Warning should be considered in order to perform a complete search.
N	D06F 37/306		Group D06F 37/306 is no longer used for the classification of documents as of February 1, 2020. The content of this group is being reclassified into groups D06F 34/08 and D06F 34/10. Groups D06F 37/306, D06F 34/08, and D06F 34/10 should be considered in order to perform a complete search.
N	D06F 37/42		Group D06F 37/42 is incomplete pending reclassification of documents from groups D06F 18/00, D06F 33/00, D06F 39/00, D06F 39/081, D06F 39/082, D06F 39/085, D06F 39/086, D06F 39/088, D06F 39/14, D06F 2204/082, and D06F 2204/084. Group D06F 37/42 is also impacted by reclassification into groups D06F 34/10, D06F 34/20, D06F 2103/40, D06F 2103/44, D06F 2105/44, D06F 2105/50, and D06F 2105/62. All groups listed in this Warning should be considered in order to perform a complete search.
N	D06F 39/00		Group D06F 39/00 is impacted by reclassification into groups D06F 31/00, D06F 31/005, D06F 33/00 - D06F 33/76, D06F 37/42, D06F 34/00 - D06F 34/34, D06F 2101/00 - D06F 2101/20, D06F 2103/02 - D06F 2103/70, and D06F 2105/50 - D06F 2105/62. All groups listed in this Warning should be considered in order to perform a complete search.

CPC NOTICE OF CHANGES 808

DATE: FEBRUARY 1, 2020

PROJECT RP0608

<u>Type*</u>	<u>Location</u>	<u>Old Warning</u>	<u>New/Modified Warning</u>
N	D06F 39/006		Group D06F 39/006 is impacted by reclassification into groups D06F 33/46, D06F 33/72, D06F 34/08, D06F 34/24, D06F 2103/44, D06F 2103/46, D06F 2103/50, and D06F 2105/26. All groups listed in this Warning should be considered in order to perform a complete search.
N	D06F 39/007		Group D06F 39/007 is impacted by reclassification into group D06F 2103/20. Groups D06F 39/007 and D06F 2103/20 should be considered in order to perform a complete search.
N	D06F 39/008		Group D06F 39/008 is impacted by reclassification into groups D06F 33/65, D06F 2103/62, and D06F 2105/40. All groups listed in this Warning should be considered in order to perform a complete search.
N	D06F 39/02		Group D06F 39/02 is impacted by reclassification into groups D06F 33/37, D06F 33/57, and D06F 2103/22. All groups listed in this Warning should be considered in order to perform a complete search.
N	D06F 39/022		Group D06F 39/022 is impacted by reclassification into groups D06F 33/37, D06F 33/57, D06F 34/08, D06F 2103/22, D06F 2105/58, and D06F 2105/60. All groups listed in this Warning should be considered in order to perform a complete search.
N	D06F 39/024		Group D06F 39/024 is impacted by reclassification into groups D06F 33/37, D06F 33/57, and D06F 2103/22. All groups listed in this Warning should be considered in order to perform a complete search.
N	D06F 39/026		Group D06F 39/026 is impacted by reclassification into groups D06F 33/37, D06F 33/57, and D06F 2103/22. All groups listed in this Warning should be considered in order to perform a complete search.
N	D06F 39/028		Group D06F 39/028 is impacted by reclassification into groups D06F 33/37, D06F 33/57, and D06F 2103/22. All groups listed in this Warning should be considered in order to perform a complete search.
N	D06F 39/04		Group D06F 39/04 is incomplete pending reclassification of documents from group D06F 39/045. Group D06F 39/04 is also impacted by reclassification into groups D06F 34/08, D06F 34/24, D06F 2103/52,

CPC NOTICE OF CHANGES 808

DATE: FEBRUARY 1, 2020

PROJECT RP0608

<u>Type*</u>	<u>Location</u>	<u>Old Warning</u>	<u>New/Modified Warning</u>
			D06F 2103/64, D06F 2105/10, and D06F 2105/28. All groups listed in this Warning should be considered in order to perform a complete search.
N	D06F 39/045		Group D06F 39/045 is no longer used for the classification of documents as of February 1, 2020. The content of this group is being reclassified into groups D06F 34/24, D06F 39/04, D06F 2103/16, and D06F 2105/10. All groups listed in this Warning should be considered in order to perform a complete search.
N	D06F 39/06		Group D06F 39/06 is impacted by reclassification into groups D06F 34/08, D06F 2105/50, D06F 2105/58, D06F 2105/60, and D06F 2105/62. All groups listed in this Warning should be considered in order to perform a complete search.
N	D06F 39/08		Group D06F 39/08 is impacted by reclassification into groups D06F 33/42, D06F 33/47, D06F 33/62, and D06F 33/74. All groups listed in this Warning should be considered in order to perform a complete search.
N	D06F 39/081		Group D06F 39/081 is impacted by reclassification into groups D06F 33/47, D06F 33/74, D06F 34/10, D06F 37/42, D06F 2105/58, and D06F 2105/60. All groups listed in this Warning should be considered in order to perform a complete search.
N	D06F 39/082		Group D06F 39/082 is impacted by reclassification into groups D06F 33/47, D06F 33/74, D06F 37/42, D06F 2103/42, D06F 2103/48, D06F 2105/58, and D06F 2105/60. All groups listed in this Warning should be considered in order to perform a complete search.
N	D06F 39/083		Group D06F 39/083 is impacted by reclassification into groups D06F 33/42, D06F 33/47, D06F 33/62, and D06F 33/74. All groups listed in this Warning should be considered in order to perform a complete search.
N	D06F 39/085		Group D06F 39/085 is impacted by reclassification into groups D06F 33/42, D06F 33/47, D06F 33/62, D06F 33/74, D06F 37/42, D06F 2103/42, and D06F 2103/48. All groups listed in this

CPC NOTICE OF CHANGES 808

DATE: FEBRUARY 1, 2020

PROJECT RP0608

<u>Type*</u>	<u>Location</u>	<u>Old Warning</u>	<u>New/Modified Warning</u>
			Warning should be considered in order to perform a complete search.
N	D06F 39/086		Group D06F 39/086 is impacted by reclassification into groups D06F 33/47, D06F 33/74, and D06F 37/42. All groups listed in this Warning should be considered in order to perform a complete search.
N	D06F 39/087		Group D06F 39/087 is impacted by reclassification into groups D06F 33/47, D06F 33/74, and D06F 2103/18. All groups listed in this Warning should be considered in order to perform a complete search.
N	D06F 39/088		Group D06F 39/088 is impacted by reclassification into groups D06F 33/47, D06F 33/74, and D06F 37/42. All groups listed in this Warning should be considered in order to perform a complete search.
N	D06F 39/10		Group D06F 39/10 is impacted by reclassification into group D06F 2103/42. Groups D06F 39/10 and D06F 2103/42 should be considered in order to perform a complete search.
N	D06F 39/12		Group D06F 39/12 is impacted by reclassification into groups D06F 34/10 and D06F 34/20. Groups D06F 39/12, D06F 34/10, and D06F 34/20 should be considered in order to perform a complete search.
N	D06F 39/125		Group D06F 39/125 is impacted by reclassification into group D06F 34/20. Groups D06F 39/125 and D06F 34/20 should be considered in order to perform a complete search.
N	D06F 39/14		Group D06F 39/14 is impacted by reclassification into groups D06F 33/47, D06F 33/74, D06F 37/42, D06F 34/10, D06F 34/20, D06F 2103/40, and D06F 2105/44. All groups listed in this Warning should be considered in order to perform a complete search.
N	D06F 58/00		Group D06F 58/00 is impacted by reclassification into groups D06F 58/30 - D06F 58/52, D06F 33/50 - D06F 33/76, D06F 34/00 - D06F 34/34, D06F 2101/00 - D06F 2101/20, D06F 2103/00 - D06F 2103/70, and D06F 2105/00 - D06F 2105/62. All groups listed in this Warning should be considered in order to perform a complete search.

CPC NOTICE OF CHANGES 808

DATE: FEBRUARY 1, 2020

PROJECT RP0608

<u>Type*</u>	<u>Location</u>	<u>Old Warning</u>	<u>New/Modified Warning</u>
N	D06F 58/02		Group D06F 58/02 is impacted by reclassification into groups D06F 34/20, D06F 34/26, D06F 33/50 - D06F 33/76, D06F 34/00 - D06F 34/34, D06F 58/30 - D06F 58/52, D06F 2101/00, D06F 2101/02, D06F 2101/00 - D06F 2101/20, D06F 2103/00 - D06F 2103/70, and D06F 2105/00 - D06F 2105/62. All groups listed in this Warning should be considered in order to perform a complete search.
N	D06F 58/04		Group D06F 58/04 is impacted by reclassification into groups D06F 34/00 - D06F 34/34, D06F 2101/00 - D06F 2101/20, D06F 2103/02 - D06F 2103/08, D06F 2103/20, D06F 2103/22, D06F 2103/40, D06F 2103/68, D06F 2103/70, D06F 2105/44, and D06F 2105/50 - D06F 2105/62. All groups listed in this Warning should be considered in order to perform a complete search.
N	D06F 58/08		Group D06F 58/08 is impacted by reclassification into groups D06F 34/10, D06F 2103/44, D06F 2103/46, D06F 2105/46, and D06F 2105/48. All groups listed in this Warning should be considered in order to perform a complete search.
N	D06F 58/10		Group D06F 58/10 is impacted by reclassification into group D06F 34/26. Groups D06F 58/10 and D06F 34/26 should be considered in order to perform a complete search.
N	D06F 58/12		Group D06F 58/12 is impacted by reclassification into group D06F 34/26. Groups D06F 58/12 and D06F 34/26 should be considered in order to perform a complete search.
N	D06F 58/14		Group D06F 58/14 is impacted by reclassification into group D06F 34/26. Groups D06F 58/14 and D06F 34/26 should be considered in order to perform a complete search.
N	D06F 58/20		Group D06F 58/20 is impacted by reclassification into groups D06F 33/63, D06F 33/64, D06F 34/04, D06F 34/05, D06F 34/10, D06F 34/16, D06F 34/18, D06F 34/20, D06F 34/26 D06F 34/34, D06F 58/45, D06F 58/52, D06F 2101/00 - D06F 2101/20, D06F 2103/02 - D06F 2103/08, D06F 2103/40,

CPC NOTICE OF CHANGES 808

DATE: FEBRUARY 1, 2020

PROJECT RP0608

<u>Type*</u>	<u>Location</u>	<u>Old Warning</u>	<u>New/Modified Warning</u>
			D06F 2103/54, D06F 2103/56, D06F 2103/68, D06F 2103/70, D06F 2105/30, D06F 2105/32, D06F 2105/36, D06F 2105/44, and D06F 2105/50 - D06F 2105/62. All groups listed in this Warning should be considered in order to perform a complete search.
N	D06F 58/203		Group D06F 58/203 is impacted by reclassification into groups D06F 33/50 - D06F 33/76, D06F 34/00 - D06F 34/34, D06F 58/30 - D06F 58/52, D06F 2101/00 - D06F 2101/20, D06F 2103/00 - D06F 2103/70, and D06F 2105/00 - D06F 2105/62. All groups listed in this Warning should be considered in order to perform a complete search.
N	D06F 58/206		Group D06F 58/206 is impacted by reclassification into groups D06F 58/48, D06F 2103/50, and D06F 2105/26. All groups listed in this Warning should be considered in order to perform a complete search.
N	D06F 58/22		Group D06F 58/22 is impacted by reclassification into groups D06F 58/45 and D06F 2105/34. Groups D06F 58/22, D06F 58/45, and D06F 2105/34 should be considered in order to perform a complete search.
N	D06F 58/24		Group D06F 58/24 is impacted by reclassification into groups D06F 58/45, D06F 2103/58, and D06F 2105/36. All groups listed in this Warning should be considered in order to perform a complete search.
N	D06F 58/26		Group D06F 58/26 is impacted by reclassification into groups D06F 2103/52 and D06F 2105/28. Groups D06F 58/26, D06F 2103/52, and D06F 2105/28 should be considered in order to perform a complete search.
N	D06F 58/263		Group D06F 58/263 is impacted by reclassification into groups D06F 2103/52 and D06F 2105/28. Groups D06F 58/263, D06F 2103/52, and D06F 2105/28 should be considered in order to perform a complete search.

CPC NOTICE OF CHANGES 808

DATE: FEBRUARY 1, 2020

PROJECT RP0608

<u>Type*</u>	<u>Location</u>	<u>Old Warning</u>	<u>New/Modified Warning</u>
N	D06F 58/266		Group D06F 58/266 is impacted by reclassification into groups D06F 2103/52, D06F 2103/64, and D06F 2105/28. All groups listed in this Warning should be considered in order to perform a complete search.
N	D06F 58/30		Group D06F 58/30 is incomplete pending reclassification of documents from groups D06F 58/00, D06F 58/02, and D06F 58/203. Group D06F 58/30 is also impacted by reclassification into groups D06F 33/50 - D06F 33/76, D06F 34/00 - D06F 34/34, D06F 58/30 - D06F 58/52, D06F 2101/00 - D06F 2101/20, D06F 2103/00 - D06F 2103/70, and D06F 2105/00 - D06F 2105/62. All groups listed in this Warning should be considered in order to perform a complete search.
N	D06F 58/32		Group D06F 58/32 - D06F 58/36 are incomplete pending reclassification of documents from groups D06F 33/00, D06F 58/00, D06F 58/02, D06F 58/203, and D06F 58/30. All groups listed in this Warning should be considered in order to perform a complete search.
N	D06F 58/38		Group D06F 58/38 is incomplete pending reclassification of documents from groups D06F 33/00, D06F 58/00, D06F 58/02, D06F 58/203, and D06F 58/30. Group D06F 58/38 is also impacted by reclassification into groups D06F 58/40, D06F 58/42, D06F 2103/00 - D06F 2103/70, and D06F 2105/00 - D06F 2105/56. All groups listed in this Warning should be considered in order to perform a complete search.
N	D06F 58/40		Group D06F 58/40 - D06F 58/44 are incomplete pending reclassification of documents from groups D06F 33/00, D06F 58/00, D06F 58/02, D06F 58/203, D06F 58/30, and D06F 58/38. All groups listed in this Warning should be considered in order to perform a complete search.
N	D06F 58/45		Group D06F 58/45 is incomplete pending reclassification of documents from groups D06F 33/00, D06F 58/00, D06F 58/02, D06F 58/20, D06F 58/203, D06F 58/22, D06F 58/24, and D06F 58/30. All groups listed in this Warning should be considered in order to perform a complete search.

CPC NOTICE OF CHANGES 808

DATE: FEBRUARY 1, 2020

PROJECT RP0608

<u>Type*</u>	<u>Location</u>	<u>Old Warning</u>	<u>New/Modified Warning</u>
N	D06F 58/46		Group D06F 58/46 is incomplete pending reclassification of documents from groups D06F 33/00, D06F 58/00, D06F 58/02, D06F 58/203, and D06F 58/30. All groups listed in this Warning should be considered in order to perform a complete search.
N	D06F 58/48		Group D06F 58/48 is incomplete pending reclassification of documents from groups D06F 33/00, D06F 58/00, D06F 58/02, D06F 58/203, D06F 58/206, and D06F 58/30. All groups listed in this Warning should be considered in order to perform a complete search.
N	D06F 58/50		Group D06F 58/50 is incomplete pending reclassification of documents from groups D06F 33/00, D06F 58/00, D06F 58/02, D06F 58/203, and D06F 58/30. Group D06F 58/50 is also impacted by reclassification into groups D06F 2105/00 - D06F 2105/62. All groups listed in this Warning should be considered in order to perform a complete search.
N	D06F 58/52		Group D06F 58/52 is incomplete pending reclassification of documents from groups D06F 33/00, D06F 58/00, D06F 58/02, D06F 58/20, D06F 58/203, and D06F 58/30. All groups listed in this Warning should be considered in order to perform a complete search.
N	D06F 2101/00		Group D06F 2101/00 is incomplete pending reclassification of documents from groups D06F 18/00, D06F 25/00, D06F 33/00, D06F 34/28, D06F 35/00, D06F 35/001 - D06F 35/008, D06F 37/00, D06F 39/00, D06F 58/00 - D06F 58/04, D06F 58/20, D06F 58/203, D06F 58/30, D06F 2202/00, D06F 2202/12, D06F 2204/00, and D06F 2214/00. Group D06F 2101/00 is also impacted by reclassification into groups D06F 2101/02 - D06F 2101/20. All groups listed in this Warning should be considered in order to perform a complete search.
N	D06F 2101/02		Group D06F 2101/02 - D06F 2101/20 are incomplete pending reclassification of documents from groups D06F 18/00, D06F 25/00, D06F 33/00, D06F 34/28, D06F 35/00 - D06F 35/008, D06F 37/00, D06F 39/00, D06F 58/00 - D06F 58/04, D06F 58/20, D06F 58/203, D06F 58/30, D06F 2101/00, D06F 2202/00, D06F 2202/12, D06F 2204/00, and

CPC NOTICE OF CHANGES 808

DATE: FEBRUARY 1, 2020

PROJECT RP0608

<u>Type*</u>	<u>Location</u>	<u>Old Warning</u>	<u>New/Modified Warning</u>
			D06F 2214/00. All groups listed in this Warning should be considered in order to perform a complete search.
N	D06F 2103/00		Group D06F 2103/00 is incomplete pending reclassification of documents from groups D06F 25/00, D06F 33/00, D06F 35/00 - D06F 35/006, D06F 58/00, D06F 58/02, D06F 58/203, D06F 58/30, D06F 58/38, D06F 2202/00, and D06F 2202/12. Group D06F 2103/00 is also impacted by reclassification into groups D06F 2103/02 - D06F 2103/70. All groups listed in this Warning should be considered in order to perform a complete search.
N	D06F 2103/02		Group D06F 2103/02 - D06F 2103/08 are incomplete pending reclassification of documents from groups D06F 18/00, D06F 25/00, D06F 33/00, D06F 34/18, D06F 35/00 - D06F 35/008, D06F 37/00, D06F 39/00, D06F 58/00 - D06F 58/04, D06F 58/20, D06F 58/203, D06F 58/30, D06F 58/38, D06F 2103/00, D06F 2202/00, D06F 2202/10, D06F 2202/12, and D06F 2204/00. All groups listed in this Warning should be considered in order to perform a complete search.
N	D06F 2103/10		Group D06F 2103/10 - D06F 2103/12 are incomplete pending reclassification of documents from groups D06F 33/00, D06F 58/00, D06F 58/02, D06F 58/203, D06F 58/30, D06F 58/38, D06F 2103/00, D06F 2202/00, and D06F 2202/12. All groups listed in this Warning should be considered in order to perform a complete search.
N	D06F 2103/14		Group D06F 2103/14 is incomplete pending reclassification of documents from groups D06F 33/00, D06F 58/00, D06F 58/02, D06F 58/203, D06F 58/30, D06F 58/38, D06F 2103/00, D06F 2202/00, D06F 2202/08, and D06F 2202/12. All groups listed in this Warning should be considered in order to perform a complete search.
N	D06F 2103/16		Group D06F 2103/16 is incomplete pending reclassification of documents from groups D06F 33/00, D06F 39/045, D06F 58/00, D06F 58/02, D06F 58/203, D06F 58/30, D06F 58/38, D06F 2103/00, D06F 2202/00, D06F 2202/04, and D06F 2202/12. All groups listed in this Warning should be

CPC NOTICE OF CHANGES 808

DATE: FEBRUARY 1, 2020

PROJECT RP0608

<u>Type*</u>	<u>Location</u>	<u>Old Warning</u>	<u>New/Modified Warning</u>
			considered in order to perform a complete search.
N	D06F 2103/18		Group D06F 2103/18 is incomplete pending reclassification of documents from groups D06F 33/00, D06F 39/087, D06F 58/00, D06F 58/02, D06F 58/203, D06F 58/30, D06F 58/38, D06F 2103/00, D06F 2202/00, D06F 2202/085, and D06F 2202/12. All groups listed in this Warning should be considered in order to perform a complete search.
N	D06F 2103/20		Group D06F 2103/20 is incomplete pending reclassification of documents from groups D06F 18/00, D06F 25/00, D06F 33/00, D06F 34/22, D06F 35/00 - D06F 35/008, D06F 37/00, D06F 39/00, D06F 39/007, D06F 58/00 - D06F 58/04, D06F 58/203, D06F 58/30, D06F 58/38, D06F 2103/00, D06F 2202/00, D06F 2202/02, D06F 2202/12, and D06F 2204/00. All groups listed in this Warning should be considered in order to perform a complete search.
N	D06F 2103/22		Group D06F 2103/22 is incomplete pending reclassification of documents from groups D06F 18/00, D06F 25/00, D06F 33/00, D06F 34/22, D06F 35/00 - D06F 35/008, D06F 37/00, D06F 39/00, D06F 39/02 - D06F 39/028, D06F 58/00, D06F 58/02, D06F 58/04, D06F 58/203, D06F 58/30, D06F 58/38, D06F 2103/00, D06F 2202/00, D06F 2202/02, D06F 2202/12, and D06F 2204/00. All groups listed in this Warning should be considered in order to perform a complete search.
N	D06F 2103/24		Group D06F 2103/24 is incomplete pending reclassification of documents from groups D06F 33/00, D06F 35/007, D06F 37/304, D06F 58/00, D06F 58/02, D06F 58/203, D06F 58/30, D06F 58/38, D06F 2103/00, D06F 2202/00, D06F 2202/06, D06F 2202/065, and D06F 2202/12. All groups listed in this Warning should be considered in order to perform a complete search.

CPC NOTICE OF CHANGES 808

DATE: FEBRUARY 1, 2020

PROJECT RP0608

<u>Type*</u>	<u>Location</u>	<u>Old Warning</u>	<u>New/Modified Warning</u>
N	D06F 2103/26		Group D06F 2103/26 is incomplete pending reclassification of documents from groups D06F 33/00, D06F 37/203, D06F 58/00, D06F 58/02, D06F 58/203, D06F 58/30, D06F 58/38, D06F 2103/00, D06F 2202/00, D06F 2202/12, and D06F 2222/00. All groups listed in this Warning should be considered in order to perform a complete search.
N	D06F 2103/28		Group D06F 2103/28 - D06F 2103/36 are incomplete pending reclassification of documents from groups D06F 33/00, D06F 58/00, D06F 58/02, D06F 58/203, D06F 58/30, D06F 58/38, D06F 2103/00, D06F 2202/00, and D06F 2202/12. All groups listed in this Warning should be considered in order to perform a complete search.
N	D06F 2103/38		Group D06F 2103/38 is incomplete pending reclassification of documents from groups D06F 33/00, D06F 58/00, D06F 58/02, D06F 58/203, D06F 58/30, D06F 58/38, D06F 2103/00, D06F 2202/00, D06F 2202/12, D06F 2212/00, D06F 2212/02, D06F 2212/04, D06F 2212/06, and D06F 2220/00. All groups listed in this Warning should be considered in order to perform a complete search.
N	D06F 2103/40		Group D06F 2103/40 is incomplete pending reclassification of documents from groups D06F 33/00, D06F 37/10, D06F 37/18, D06F 37/302, D06F 37/42, D06F 39/14, D06F 58/00 - D06F 58/04, D06F 58/20, D06F 58/203, D06F 58/30, D06F 58/38, D06F 2103/00, D06F 2202/00, D06F 2202/12, and D06F 2224/00. All groups listed in this Warning should be considered in order to perform a complete search.
N	D06F 2103/42		Group D06F 2103/42 is incomplete pending reclassification of documents from groups D06F 33/00, D06F 39/082, D06F 39/085, D06F 39/10, D06F 58/00, D06F 58/02, D06F 58/203, D06F 58/30, D06F 58/38, D06F 2103/00, D06F 2202/00, D06F 2202/08, and D06F 2202/12. All groups listed in this Warning should be considered in order to perform a complete search.

CPC NOTICE OF CHANGES 808

DATE: FEBRUARY 1, 2020

PROJECT RP0608

<u>Type*</u>	<u>Location</u>	<u>Old Warning</u>	<u>New/Modified Warning</u>
N	D06F 2103/44		Group D06F 2103/44 is incomplete pending reclassification of documents from groups D06F 33/00, D06F 37/42, D06F 39/006, D06F 58/00, D06F 58/02, D06F 58/08, D06F 58/203, D06F 58/30, D06F 58/38, D06F 2103/00, D06F 2202/00, and D06F 2202/12. All groups listed in this Warning should be considered in order to perform a complete search.
N	D06F 2103/46		Group D06F 2103/46 is incomplete pending reclassification of documents from groups D06F 33/00, D06F 37/203, D06F 37/304, D06F 39/006, D06F 58/00, D06F 58/02, D06F 58/08, D06F 58/203, D06F 58/30, D06F 58/38, D06F 2103/00, D06F 2202/00, D06F 2202/06, D06F 2202/065, and D06F 2202/12. All groups listed in this Warning should be considered in order to perform a complete search.
N	D06F 2103/48		Group D06F 2103/48 is incomplete pending reclassification of documents from groups D06F 33/00, D06F 39/082, D06F 39/085, D06F 58/00, D06F 58/02, D06F 58/203, D06F 58/30, D06F 58/38, D06F 2103/00, D06F 2202/00, D06F 2202/08, and D06F 2202/12. All groups listed in this Warning should be considered in order to perform a complete search.
N	D06F 2103/50		Group D06F 2103/50 is incomplete pending reclassification of documents from groups D06F 33/00, D06F 39/006, D06F 58/00, D06F 58/02, D06F 58/203, D06F 58/206, D06F 58/30, D06F 58/38, D06F 2103/00, D06F 2202/00, D06F 2202/12, and D06F 2226/00. All groups listed in this Warning should be considered in order to perform a complete search.
N	D06F 2103/52		Group D06F 2103/52 is incomplete pending reclassification of documents from groups D06F 33/00, D06F 39/04, D06F 58/00, D06F 58/02, D06F 58/203, D06F 58/26, D06F 58/263, D06F 58/266, D06F 58/30, D06F 58/38, D06F 2103/00, D06F 2202/00, D06F 2202/04, and D06F 2202/12. All groups listed in this Warning should be considered in order to perform a complete search.
N	D06F 2103/54		Groups D06F 2103/54 - D06F 2103/56 are incomplete pending reclassification of documents from groups D06F 33/00, D06F 58/00, D06F 58/02, D06F 58/20,

CPC NOTICE OF CHANGES 808

DATE: FEBRUARY 1, 2020

PROJECT RP0608

<u>Type*</u>	<u>Location</u>	<u>Old Warning</u>	<u>New/Modified Warning</u>
			D06F 58/203, D06F 58/30, D06F 58/38, D06F 2103/00, D06F 2202/00, and D06F 2202/12. All groups listed in this Warning should be considered in order to perform a complete search.
N	D06F 2103/58		Group D06F 2103/58 is incomplete pending reclassification of documents from groups D06F 33/00, D06F 58/00, D06F 58/02, D06F 58/203, D06F 58/24, D06F 58/30, D06F 58/38, D06F 2103/00, D06F 2202/00, and D06F 2202/12. All groups listed in this Warning should be considered in order to perform a complete search.
N	D06F 2103/60		Group D06F 2103/60 is incomplete pending reclassification of documents from groups D06F 33/00, D06F 58/00, D06F 58/02, D06F 58/203, D06F 58/30, D06F 58/38, D06F 2103/00, D06F 2202/00, and D06F 2202/12. All groups listed in this Warning should be considered in order to perform a complete search.
N	D06F 2103/62		Group D06F 2103/62 is incomplete pending reclassification of documents from groups D06F 33/00, D06F 39/008, D06F 58/00, D06F 58/02, D06F 58/203, D06F 58/30, D06F 58/38, D06F 2103/00, D06F 2202/00, and D06F 2202/12. All groups listed in this Warning should be considered in order to perform a complete search.
N	D06F 2103/64		Group D06F 2103/64 is incomplete pending reclassification of documents from groups D06F 33/00, D06F 39/04, D06F 58/00, D06F 58/02, D06F 58/203, D06F 58/266, D06F 58/30, D06F 58/38, D06F 2103/00, D06F 2202/00, and D06F 2202/12. All groups listed in this Warning should be considered in order to perform a complete search.
N	D06F 2103/66		Group D06F 2103/66 is incomplete pending reclassification of documents from groups D06F 19/00, D06F 33/00, D06F 35/00, D06F 35/001, D06F 35/003 - D06F 35/005, D06F 58/00, D06F 58/02, D06F 58/203, D06F 58/30, D06F 58/38, D06F 2103/00, D06F 2202/00, D06F 2202/10, D06F 2202/12, and D06F 2204/10. All groups listed in this Warning should be considered in order to perform a complete search.

CPC NOTICE OF CHANGES 808

DATE: FEBRUARY 1, 2020

PROJECT RP0608

<u>Type*</u>	<u>Location</u>	<u>Old Warning</u>	<u>New/Modified Warning</u>
N	D06F 2103/68		Group D06F 2103/68 - D06F 2103/70 are incomplete pending reclassification of documents from groups D06F 18/00, D06F 25/00, D06F 33/00, D06F 34/28, D06F 35/00 - D06F 35/008, D06F 37/00, D06F 39/00, D06F 58/00, D06F 58/02, D06F 58/04, D06F 58/20, D06F 58/203, D06F 58/30, D06F 58/38, D06F 2103/00, D06F 2202/00, D06F 2202/12, and D06F 2204/00. All groups listed in this Warning should be considered in order to perform a complete search.
N	D06F 2105/00		Group D06F 2105/00 is incomplete pending reclassification of documents from groups D06F 33/00, D06F 58/00, D06F 58/02, D06F 58/203, D06F 58/30, D06F 58/38, D06F 58/50, D06F 2204/00, and D06F 2204/10. All groups listed in this Warning should be considered in order to perform a complete search.
N	D06F 2105/02		Group D06F 2105/02 is incomplete pending reclassification of documents from groups D06F 33/00, D06F 58/00, D06F 58/02, D06F 58/203, D06F 58/30, D06F 58/38, D06F 58/50, D06F 2204/08, and D06F 2204/086. All groups listed in this Warning should be considered in order to perform a complete search.
N	D06F 2105/04		Group D06F 2105/04 is incomplete pending reclassification of documents from groups D06F 33/00, D06F 58/00, D06F 58/02, D06F 58/203, D06F 58/30, D06F 58/38, D06F 58/50, and D06F 2204/088. All groups listed in this Warning should be considered in order to perform a complete search.
N	D06F 2105/06		Group D06F 2105/06 is incomplete pending reclassification of documents from groups D06F 33/00, D06F 58/00, D06F 58/02, D06F 58/203, D06F 58/30, D06F 58/38, D06F 58/50, D06F 2204/08, and D06F 2204/082. All groups listed in this Warning should be considered in order to perform a complete search.
N	D06F 2105/08		Group D06F 2105/08 is incomplete pending reclassification of documents from groups D06F 33/00, D06F 58/00, D06F 58/02, D06F 58/203, D06F 58/30, D06F 58/38, D06F 58/50, D06F 2204/08, and D06F 2204/084. All groups listed in this

CPC NOTICE OF CHANGES 808

DATE: FEBRUARY 1, 2020

PROJECT RP0608

<u>Type*</u>	<u>Location</u>	<u>Old Warning</u>	<u>New/Modified Warning</u>
			Warning should be considered in order to perform a complete search.
N	D06F 2105/10		Group D06F 2105/10 is incomplete pending reclassification of documents from groups D06F 33/00, D06F 39/04, D06F 39/045, D06F 58/00, D06F 58/02, D06F 58/203, D06F 58/30, D06F 58/38, D06F 58/50, and D06F 2204/04. All groups listed in this Warning should be considered in order to perform a complete search.
N	D06F 2105/12		Group D06F 2105/12 is incomplete pending reclassification of documents from groups D06F 33/00, D06F 58/00, D06F 58/02, D06F 58/203, D06F 58/30, D06F 58/38, D06F 58/50, and D06F 2204/10. All groups listed in this Warning should be considered in order to perform a complete search.
N	D06F 2105/14		Group D06F 2105/14 - D06F 2105/24 are incomplete pending reclassification of documents from groups D06F 33/00, D06F 58/00, D06F 58/02, D06F 58/203, D06F 58/30, D06F 58/38, and D06F 58/50. All groups listed in this Warning should be considered in order to perform a complete search.
N	D06F 2105/26		Group D06F 2105/26 is incomplete pending reclassification of documents from groups D06F 33/00, D06F 39/006, D06F 58/00, D06F 58/02, D06F 58/203, D06F 58/206, D06F 58/30, D06F 58/38, D06F 58/50, and D06F 2226/00. All groups listed in this Warning should be considered in order to perform a complete search.
N	D06F 2105/28		Group D06F 2105/28 is incomplete pending reclassification of documents from groups D06F 33/00, D06F 39/04, D06F 58/00, D06F 58/02, D06F 58/203, D06F 58/26, D06F 58/263, D06F 58/266, D06F 58/30, D06F 58/38, D06F 58/50, D06F 2202/12, and D06F 2204/04. All groups listed in this Warning should be considered in order to perform a complete search.
N	D06F 2105/30		Group D06F 2105/30 - D06F 2105/32 are incomplete pending reclassification of documents from groups D06F 33/00, D06F 58/00, D06F 58/02, D06F 58/20, D06F 58/203, D06F 58/30, D06F 58/38, and D06F 58/50. All groups listed in this Warning should be considered in order to perform a complete search.

CPC NOTICE OF CHANGES 808

DATE: FEBRUARY 1, 2020

PROJECT RP0608

<u>Type*</u>	<u>Location</u>	<u>Old Warning</u>	<u>New/Modified Warning</u>
N	D06F 2105/34		Group D06F 2105/34 is incomplete pending reclassification of documents from groups D06F 33/00, D06F 58/00, D06F 58/02, D06F 58/203, D06F 58/22, D06F 58/30, D06F 58/38, and D06F 58/50. All groups listed in this Warning should be considered in order to perform a complete search.
N	D06F 2105/36		Group D06F 2105/36 is incomplete pending reclassification of documents from groups D06F 33/00, D06F 58/00, D06F 58/02, D06F 58/20, D06F 58/203, D06F 58/24, D06F 58/30, D06F 58/38, and D06F 58/50. All groups listed in this Warning should be considered in order to perform a complete search.
N	D06F 2105/38		Group D06F 2105/38 is incomplete pending reclassification of documents from groups D06F 33/00, D06F 58/00, D06F 58/02, D06F 58/203, D06F 58/30, D06F 58/38, and D06F 58/50. All groups listed in this Warning should be considered in order to perform a complete search.
N	D06F 2105/40		Group D06F 2105/40 is incomplete pending reclassification of documents from groups D06F 33/00, D06F 39/008, D06F 58/00, D06F 58/02, D06F 58/203, D06F 58/30, D06F 58/38, D06F 58/50, and D06F 2202/12. All groups listed in this Warning should be considered in order to perform a complete search.
N	D06F 2105/42		Group D06F 2105/42 is incomplete pending reclassification of documents from groups D06F 33/00, D06F 58/00, D06F 58/02, D06F 58/203, D06F 58/30, D06F 58/38, D06F 58/50, and D06F 2204/02. All groups listed in this Warning should be considered in order to perform a complete search.
N	D06F 2105/44		Group D06F 2105/44 is incomplete pending reclassification of documents from groups D06F 33/00, D06F 37/10, D06F 37/18, D06F 37/302, D06F 37/42, D06F 39/14, D06F 58/00, D06F 58/04, D06F 58/20, D06F 58/203, D06F 58/30, D06F 58/38, D06F 58/50, and D06F 2224/00. All groups listed in this Warning should be considered in order to perform a complete search.
N	D06F 2105/46		Group D06F 2105/46 is incomplete pending reclassification of documents from groups D06F 33/00, D06F 37/304, D06F 58/00, D06F 58/02, D06F 58/08, D06F 58/203, D06F 58/30, D06F 58/38, D06F 58/50, and

CPC NOTICE OF CHANGES 808

DATE: FEBRUARY 1, 2020

PROJECT RP0608

<u>Type*</u>	<u>Location</u>	<u>Old Warning</u>	<u>New/Modified Warning</u>
			D06F 2204/06. All groups listed in this Warning should be considered in order to perform a complete search.
N	D06F 2105/48		Group D06F 2105/48 is incomplete pending reclassification of documents from groups D06F 33/00, D06F 37/304, D06F 58/00, D06F 58/02, D06F 58/08, D06F 58/203, D06F 58/30, D06F 58/38, D06F 58/50, and D06F 2204/065. All groups listed in this Warning should be considered in order to perform a complete search.
N	D06F 2105/50		Group D06F 2105/50 is incomplete pending reclassification of documents from groups D06F 18/00, D06F 25/00, D06F 33/00, D06F 34/28, D06F 35/00 - D06F 35/008, D06F 37/00, D06F 37/42, D06F 39/00, D06F 39/06, D06F 58/00 - D06F 58/04, D06F 58/20, D06F 58/203, D06F 58/30, D06F 58/38, D06F 58/50, D06F 2202/00, D06F 2202/12, D06F 2204/00, D06F 2204/10, and D06F 2212/06. All groups listed in this Warning should be considered in order to perform a complete search.
N	D06F 2105/52		Group D06F 2105/52 is incomplete pending reclassification of documents from groups D06F 18/00, D06F 25/00, D06F 33/00, D06F 34/28, D06F 35/00 - D06F 35/008, D06F 37/00, D06F 39/00, D06F 58/00, D06F 58/02, D06F 58/04, D06F 58/20, D06F 58/203, D06F 58/30, D06F 58/38, D06F 58/50, D06F 2202/00, D06F 2202/12, and D06F 2204/00. All groups listed in this Warning should be considered in order to perform a complete search.
N	D06F 2105/54		Group D06F 2105/54 is incomplete pending reclassification of documents from groups D06F 18/00, D06F 25/00, D06F 33/00, D06F 34/28, D06F 35/00 - D06F 35/008, D06F 37/00, D06F 39/00, D06F 58/00, D06F 58/02, D06F 58/04, D06F 58/20, D06F 58/203, D06F 58/30, D06F 58/38, D06F 58/50, D06F 2202/00, D06F 2202/12, D06F 2204/00, D06F 2214/00, and D06F 2216/00. All groups listed in this Warning should be considered in order to perform a complete search.
N	D06F 2105/56		Group D06F 2105/56 is incomplete pending reclassification of documents from groups D06F 18/00, D06F 25/00, D06F 33/00, D06F 34/28, D06F 35/00 - D06F 35/008,

CPC NOTICE OF CHANGES 808

DATE: FEBRUARY 1, 2020

PROJECT RP0608

<u>Type*</u>	<u>Location</u>	<u>Old Warning</u>	<u>New/Modified Warning</u>
			D06F 37/00, D06F 39/00, D06F 58/00, D06F 58/02, D06F 58/04, D06F 58/20, D06F 58/203, D06F 58/30, D06F 58/38, D06F 58/50, D06F 2202/00, D06F 2202/12, D06F 2204/00, D06F 2212/00, D06F 2212/02, and D06F 2220/00. All groups listed in this Warning should be considered in order to perform a complete search.
N	D06F 2105/58		Group D06F 2105/58 is incomplete pending reclassification of documents from groups D06F 18/00, D06F 25/00, D06F 33/00, D06F 34/28, D06F 35/00 - D06F 35/008, D06F 37/00, D06F 39/00, D06F 39/022, D06F 39/06, D06F 39/081, D06F 39/082, D06F 58/00, D06F 58/02, D06F 58/04, D06F 58/20, D06F 58/203, D06F 58/30, D06F 58/50, D06F 2202/00, D06F 2202/12, D06F 2204/00, D06F 2210/00, D06F 2216/00, and D06F 2224/00. All groups listed in this Warning should be considered in order to perform a complete search.
N	D06F 2105/60		Group D06F 2105/60 is incomplete pending reclassification of documents from groups D06F 18/00, D06F 25/00, D06F 33/00, D06F 34/28, D06F 35/00 - D06F 35/008, D06F 37/00, D06F 39/00, D06F 39/022, D06F 39/06, D06F 39/081, D06F 39/082, D06F 58/00, D06F 58/02, D06F 58/04, D06F 58/20, D06F 58/203, D06F 58/30, D06F 58/50, D06F 2202/00, D06F 2202/12, D06F 2204/00, D06F 2204/10, and D06F 2224/00. All groups listed in this Warning should be considered in order to perform a complete search.
N	D06F 2105/62		Group D06F 2105/62 is incomplete pending reclassification of documents from groups D06F 18/00, D06F 25/00, D06F 33/00, D06F 34/28, D06F 35/00 - D06F 35/008, D06F 37/00, D06F 37/42, D06F 39/00, D06F 39/06, D06F 58/00, D06F 58/02, D06F 58/04, D06F 58/20, D06F 58/203, D06F 58/30, D06F 58/50, D06F 2202/00, D06F 2202/12, D06F 2204/00, D06F 2204/10, and D06F 2212/06. All groups listed in this Warning should be considered in order to perform a complete search.

CPC NOTICE OF CHANGES 808

DATE: FEBRUARY 1, 2020

PROJECT RP0608

<u>Type*</u>	<u>Location</u>	<u>Old Warning</u>	<u>New/Modified Warning</u>
N	D06F 2202/00		Group D06F 2202/00 is no longer used for the classification of documents as of February 1, 2020. The content of this group is being reclassified into groups D06F 33/30, D06F 33/50 - D06F 33/76, D06F 34/00 - D06F 34/34, D06F 2101/00 - D06F 2101/20, D06F 2103/00 - D06F 2103/70, and D06F 2105/50 - D06F 2105/62. All groups listed in this Warning should be considered in order to perform a complete search.
N	D06F 2202/02		Group D06F 2202/02 is no longer used for the classification of documents as of February 1, 2020. The content of this group is being reclassified into groups D06F 33/30, D06F 33/50 - D06F 33/76, D06F 2103/20, and D06F 2103/22. All groups listed in this Warning should be considered in order to perform a complete search.
N	D06F 2202/04		Group D06F 2202/04 is no longer used for the classification of documents as of February 1, 2020. The content of this group is being reclassified into groups D06F 33/30, D06F 33/50, D06F 33/52, D06F 33/54 - D06F 33/76, D06F 34/24, D06F 2103/16, and D06F 2103/52. All groups listed in this Warning should be considered in order to perform a complete search.
N	D06F 2202/06		Group D06F 2202/06 is no longer used for the classification of documents as of February 1, 2020. The content of this group is being reclassified into groups D06F 33/30, D06F 33/50 - D06F 33/76, D06F 2103/24, and D06F 2103/46. All groups listed in this Warning should be considered in order to perform a complete search.
N	D06F 2202/065		Group D06F 2202/065 is no longer used for the classification of documents as of February 1, 2020. The content of this group is being reclassified into groups D06F 33/30, D06F 33/50 - D06F 33/76, D06F 2103/24, and D06F 2103/46. All groups listed in this Warning should be considered in order to perform a complete search.

CPC NOTICE OF CHANGES 808

DATE: FEBRUARY 1, 2020

PROJECT RP0608

<u>Type*</u>	<u>Location</u>	<u>Old Warning</u>	<u>New/Modified Warning</u>
N	D06F 2202/08		Group D06F 2202/08 is no longer used for the classification of documents as of February 1, 2020. The content of this group is being reclassified into groups D06F 33/30, D06F 33/50 - D06F 33/76, D06F 2103/14, D06F 2103/42, and D06F 2103/48. All groups listed in this Warning should be considered in order to perform a complete search.
N	D06F 2202/085		Group D06F 2202/085 is no longer used for the classification of documents as of February 1, 2020. The content of this group is being reclassified into groups D06F 33/30, D06F 33/50 - D06F 33/76, and D06F 2103/18. All groups listed in this Warning should be considered in order to perform a complete search.
N	D06F 2202/10		Group D06F 2202/10 is no longer used for the classification of documents as of February 1, 2020. The content of this group is being reclassified into groups D06F 33/30 - D06F 33/76, D06F 2103/02, D06F 2103/04, D06F 2103/06, D06F 2103/08, and D06F 2103/66. All groups listed in this Warning should be considered in order to perform a complete search.
N	D06F 2202/12		Group D06F 2202/12 is no longer used for the classification of documents as of February 1, 2020. The content of this group is being reclassified into groups D06F 33/30, D06F 33/36, D06F 33/50 - D06F 33/76, D06F 34/00 - D06F 34/34, D06F 2101/00 - D06F 2101/20, D06F 2103/00 - D06F 2103/70, D06F 2105/28, D06F 2105/40, and D06F 2105/50 - D06F 2105/62. All groups listed in this Warning should be considered in order to perform a complete search.
N	D06F 2204/00		Group D06F 2204/00 is no longer used for the classification of documents as of February 1, 2020. The content of this group is being reclassified into groups D06F 33/30, D06F 33/36, D06F 33/38, D06F 33/43 -D06F 33/76, D06F 34/00, D06F 34/04 - D06F 34/34, and D06F 2101/00 - D06F 2105/62. All groups listed in this Warning should be considered in order to perform a complete search.

CPC NOTICE OF CHANGES 808

DATE: FEBRUARY 1, 2020

PROJECT RP0608

<u>Type*</u>	<u>Location</u>	<u>Old Warning</u>	<u>New/Modified Warning</u>
N	D06F 2204/02		Group D06F 2204/02 is no longer used for the classification of documents as of February 1, 2020. The content of this group is being reclassified into groups D06F 33/30, D06F 33/36 - D06F 33/76, and D06F 2105/42. All groups listed in this Warning should be considered in order to perform a complete search.
N	D06F 2204/04		Group D06F 2204/04 is no longer used for the classification of documents as of February 1, 2020. The content of this group is being reclassified into groups D06F 33/30, D06F 33/36 - D06F 33/76, D06F 34/24, D06F 2105/10, and D06F 2105/28. All groups listed in this Warning should be considered in order to perform a complete search.
N	D06F 2204/06		Group D06F 2204/06 is no longer used for the classification of documents as of February 1, 2020. The content of this group is being reclassified into groups D06F 33/30, D06F 33/36 - D06F 33/76, and D06F 2105/46. All groups listed in this Warning should be considered in order to perform a complete search.
N	D06F 2204/065		Group D06F 2204/065 is no longer used for the classification of documents as of February 1, 2020. The content of this group is being reclassified into groups D06F 33/30, D06F 33/36 - D06F 33/76, and D06F 2105/48. All groups listed in this Warning should be considered in order to perform a complete search.
N	D06F 2204/08		Group D06F 2204/08 is no longer used for the classification of documents as of February 1, 2020. The content of this group is being reclassified into groups D06F 33/30, D06F 33/36 - D06F 33/76, D06F 2105/02, D06F 2105/06, and D06F 2105/08. All groups listed in this Warning should be considered in order to perform a complete search.
N	D06F 2204/082		Group D06F 2204/082 is no longer used for the classification of documents as of February 1, 2020. The content of this group is being reclassified into groups D06F 33/30, D06F 33/36 - D06F 33/76, D06F 2105/06, and D06F 37/42. All groups listed in this Warning should be considered in order to perform a complete search.

CPC NOTICE OF CHANGES 808

DATE: FEBRUARY 1, 2020

PROJECT RP0608

<u>Type*</u>	<u>Location</u>	<u>Old Warning</u>	<u>New/Modified Warning</u>
N	D06F 2204/084		Group D06F 2204/084 is no longer used for the classification of documents as of February 1, 2020. The content of this group is being reclassified into groups D06F 33/30, D06F 33/36 - D06F 33/76, D06F 37/42 and D06F 2105/08. All groups listed in this Warning should be considered in order to perform a complete search.
N	D06F 2204/086		Group D06F 2204/086 is no longer used for the classification of documents as of February 1, 2020. The content of this group is being reclassified into groups D06F 33/30, D06F 33/34 - D06F 33/76, and D06F 2105/02. All groups listed in this Warning should be considered in order to perform a complete search.
N	D06F 2204/088		Group D06F 2204/088 is no longer used for the classification of documents as of February 1, 2020. The content of this group is being reclassified into groups D06F 33/30, D06F 33/34 - D06F 33/76, and D06F 2105/04. All groups listed in this Warning should be considered in order to perform a complete search.
N	D06F 2204/10		Group D06F 2204/10 is no longer used for the classification of documents as of February 1, 2020. The content of this group is being reclassified into groups D06F 33/30, D06F 33/36 - D06F 33/76, D06F 34/04, D06F 34/05, D06F 2103/66, D06F 2105/00, D06F 2105/12, D06F 2105/50, D06F 2105/60, and D06F 2105/62. All groups listed in this Warning should be considered in order to perform a complete search.
N	D06F 2210/00		Group D06F 2210/00 is no longer used for the classification of documents as of February 1, 2020. The content of this group is being reclassified into groups D06F 33/30, D06F 33/50 - D06F 33/76, D06F 34/04, D06F 34/05, and D06F 2105/58. All groups listed in this Warning should be considered in order to perform a complete search.
N	D06F 2212/00		Group D06F 2212/00 is no longer used for the classification of documents as of February 1, 2020. The content of this group is being reclassified into groups D06F 33/30, D06F 33/44, D06F 33/50 - D06F 33/76, D06F 34/06, D06F 2103/38, and D06F 2105/56. All groups listed in this

CPC NOTICE OF CHANGES 808

DATE: FEBRUARY 1, 2020

PROJECT RP0608

<u>Type*</u>	<u>Location</u>	<u>Old Warning</u>	<u>New/Modified Warning</u>
			Warning should be considered in order to perform a complete search.
N	D06F 2212/02		Group D06F 2212/02 is no longer used for the classification of documents as of February 1, 2020. The content of this group is being reclassified into groups D06F 33/30, D06F 33/44, D06F 33/50 - D06F 33/76, D06F 34/06, D06F 2103/38, and D06F 2105/56. All groups listed in this Warning should be considered in order to perform a complete search.
N	D06F 2212/04		Group D06F 2212/04 is no longer used for the classification of documents as of February 1, 2020. The content of this group is being reclassified into groups D06F 33/30, D06F 33/44, D06F 33/50 - D06F 33/76, D06F 34/06, and D06F 2103/38. All groups listed in this Warning should be considered in order to perform a complete search.
N	D06F 2212/06		Group D06F 2212/06 is no longer used for the classification of documents as of February 1, 2020. The content of this group is being reclassified into groups D06F 33/30, D06F 33/44, D06F 33/50 - D06F 33/76, D06F 34/06, D06F 2103/38, D06F 2105/50, and D06F 2105/62. All groups listed in this Warning should be considered in order to perform a complete search.
N	D06F 2214/00		Group D06F 2214/00 is no longer used for the classification of documents as of February 1, 2020. The content of this group is being reclassified into groups D06F 33/30, D06F 33/50 - D06F 33/76, D06F 2101/00 - D06F 2101/20, and D06F 2105/54. All groups listed in this Warning should be considered in order to perform a complete search.
N	D06F 2216/00		Group D06F 2216/00 is no longer used for the classification of documents as of February 1, 2020. The content of this group is being reclassified into groups D06F 33/30, D06F 33/50 - D06F 33/76, D06F 34/04, D06F 34/05, D06F 2105/54, and D06F 2105/58. All groups listed in this Warning should be considered in order to perform a complete search.

CPC NOTICE OF CHANGES 808

DATE: FEBRUARY 1, 2020

PROJECT RP0608

<u>Type*</u>	<u>Location</u>	<u>Old Warning</u>	<u>New/Modified Warning</u>
N	D06F 2220/00		Group D06F 2220/00 is no longer used for the classification of documents as of February 1, 2020. The content of this group is being reclassified into groups D06F 33/30, D06F 33/44, D06F 33/48 - D06F 33/76, D06F 34/06, D06F 2103/38, and D06F 2105/56. All groups listed in this Warning should be considered in order to perform a complete search.
N	D06F 2222/00		Group D06F 2222/00 is no longer used for the classification of documents as of February 1, 2020. The content of this group is being reclassified into groups D06F 33/30, D06F 33/50 - D06F 33/76, D06F 34/16, and D06F 2103/26. All groups listed in this Warning should be considered in order to perform a complete search.
N	D06F 2224/00		Group D06F 2224/00 is no longer used for the classification of documents as of February 1, 2020. The content of this group is being reclassified into groups D06F 33/30, D06F 33/47, D06F 33/50 - D06F 33/76, D06F 2103/40, D06F 2105/44, D06F 2105/58, and D06F 2105/60. All groups listed in this Warning should be considered in order to perform a complete search.
N	D06F 2226/00		Group D06F 2226/00 is no longer used for the classification of documents as of February 1, 2020. The content of this group is being reclassified into groups D06F 33/30, D06F 33/46, D06F 33/50 - D06F 33/76, D06F 34/24, D06F 2103/50, and D06F 2105/26. All groups listed in this Warning should be considered in order to perform a complete search.

*N = new warning, M = modified warning, D = deleted warning

NOTE: The "Location" column only requires the symbol PRIOR to the location of the warning. No further directions such as "before" or "after" are required.

CPC NOTICE OF CHANGES 808

DATE: FEBRUARY 1, 2020

PROJECT RP0608

C. New, Modified or Deleted Note(s)

SUBCLASS D06F - LAUNDERING, DRYING, IRONING, PRESSING OR FOLDING TEXTILE ARTICLES (apparatus for blocking, pressing, steaming, or stretching hats A42C; treating textile materials by liquids, gases or vapours D06B; chemical matters, see D06L, D06M)

<u>Type*</u>	<u>Location</u>	<u>Old Note</u>	<u>New/Modified Note</u>
M	D06F	2. This subclass <u>does not cover</u> : <ul style="list-style-type: none"> apparatus for wringing, washing, dry-cleaning, ironing, or other hot-pressing of textiles in manufacturing operations, which is covered by subclasses D06B, D06C 	<u>INSERT</u> the following text as the <u>last</u> bulleted paragraph in existing Note 2. <ul style="list-style-type: none"> treatment of textiles by purely chemical means, which is covered by subclasses D06L, D06M.
N	D06F 33/00		In this group, it is mandatory to add the indexing codes of groups D06F 2101/00 - D06F 2105/00.
N	D06F 34/00		In this group, it is mandatory to add the indexing codes of groups D06F 2101/00 - D06F 2105/00.
N	D06F 58/00		In this group, it is mandatory to add the indexing codes of groups D06F 2101/00 - D06F 2105/00.
D	D06F 2058/2896	If output = input, only the input is indexed (D06F2058/2812)	Delete the entire note.

*N = new note, M = modified note, D = deleted note

NOTE: The "Location" column only requires the symbol PRIOR to the location of the note. No further directions such as "before" or "after" are required.

CPC NOTICE OF CHANGES 808

DATE: FEBRUARY 1, 2020

PROJECT RP0608

D. New, Modified or Deleted Guidance Heading(s)

SUBCLASS D06F - LAUNDERING, DRYING, IRONING, PRESSING OR FOLDING TEXTILE ARTICLES (apparatus for blocking, pressing, steaming, or stretching hats A42C; treating textile materials by liquids, gases or vapours D06B; chemical matters, see D06L, D06M)

<u>Type*</u>	<u>Location</u>	<u>Old Guidance Heading</u>	<u>New/Modified Guidance Heading</u>
M	D06F 61/00- D06F 85/00	Ironing; Pressing (smoothing by cold rolling D06F45/00)	<u>Replace</u> the existing Guidance Heading with the following text: Ironing; Pressing
M	D06F 87/00 – D06F 95/008	Miscellaneous laundry apparatus or systems	<u>Replace</u> the existing text with the following: Other laundry apparatus or systems
N	D06F 2101/00 – D06F 2105/62		<u>Insert</u> the following <u>new</u> Guidance Heading: Indexing scheme associated with groups D06F 33/00, D06F 34/00, D06F 58/00

*N = new guidance heading, M = modified guidance heading, D = deleted guidance heading

NOTES:

- The “Location” column requires the symbol AFTER the guidance heading location. No further directions such as “before” or “after” are required.
- In cases where there may be confusion as to whether a new group falls within the scope of a guidance heading, indicate the guidance heading and whether the group does or does not go with the guidance heading. This can be included in the “Location” column. For example, the guidance heading “Compounds containing carbon together with sulfur, selenium or tellurium with or without hydrogen, halogens, oxygen or nitrogen” encompasses groups C07C 301/00-395/00 only. If a new group C07C 398/00 is proposed and is included in the guidance heading scope, indicate this in the “Location” column as follows: 398/00 to be included under the guidance heading: “Compounds containing carbon together with sulfur, selenium or tellurium with or without hydrogen, halogens, oxygen or nitrogen.”

2. A. DEFINITIONS (new)

Insert the following new definitions.

D06F 33/30

Definition statement

This place covers:

The controlling processes of washing machines that are classified in this group and its subgroups according to their specific purpose, e.g. the optimization / improvement of the washing phase or the prevention of imbalance or noise. The further information relating to the (manual and/or automatic) input and the output of these controlling processes is classified with the mandatory indexing codes and any details of the control means per se, i.e. the “hardware” is classified in the groups relating to the details of the control means (see special rules of classification for this group and its subgroups).

Concept

The following picture schematically illustrates how a controlling process of a washing machine, washer-dryer or laundry dryer is classified based on how it works. An input signal (i.e. a user input as “manual input” or an automatically detected signal as “automatic input”, e.g. by a sensors) is fed into a control unit as “control means”, which depending on the purpose of the control sends corresponding command signals to the machine components.

DATE: FEBRUARY 1, 2020

PROJECT RP0608

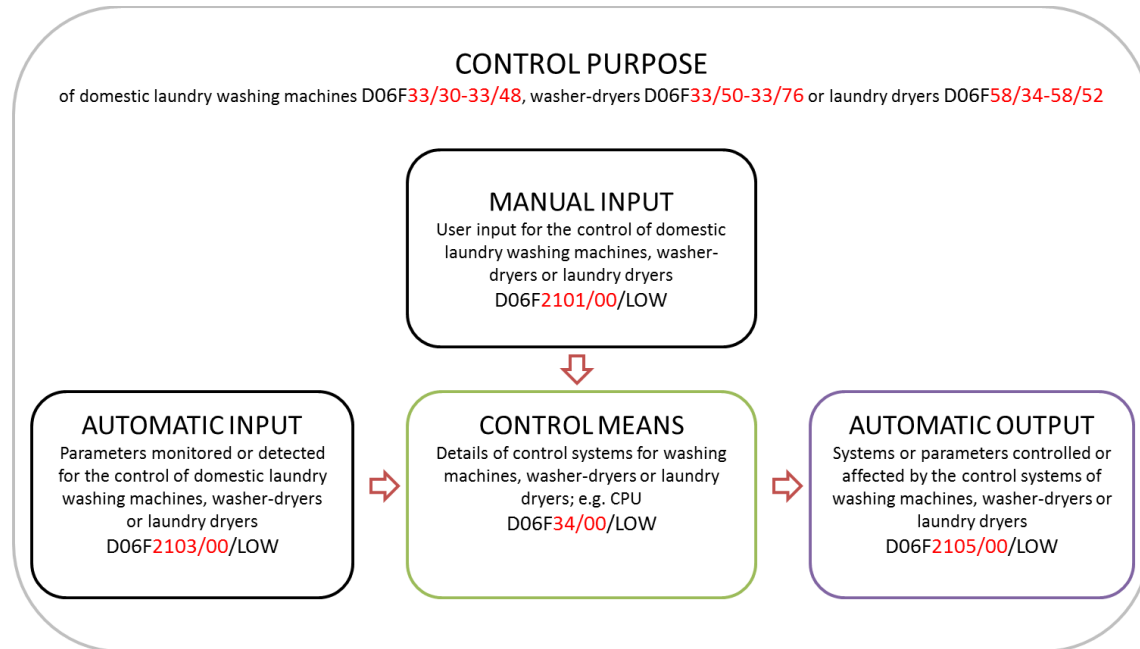

A controlling process for a laundry treating apparatus (e.g. a washing machine) has a specific “control purpose” and implies the presence of a “control means” (e.g. a CPU), whereby the control means is usually a control unit which comprises a user interface (e.g. a control panel) and several sensors for the automatic detection of e.g. temperature, pressure, liquid level, etc.

Moreover, the control unit is usually configured to perform actions as “automatic output” (e.g. switching a heater ON/OFF, regulating the drum speed, etc.), depending on the purpose of the control and based on the input of the user and/or the signals provided by the sensors.

Example: washing machine - control method

Control method for a washing machine employing a control unit adapted to detect the level and the temperature of the washing liquid and to switch the tub heater ON/OFF based on the laundry load, as input by the user, such as to reduce the energy consumption.

Classification of the example:

- Purpose: D06F 33/46 (Control of the energy or water consumption)
- Manual input: D06F 2101/04 (Characteristics of laundry or load – Quantity, e.g. weight)

DATE: FEBRUARY 1, 2020

PROJECT RP0608

- Automatic input: [D06F 2103/16](#) (Washing liquid temperature); [D06F 2103/18](#) (Washing liquid level)
- Automatic output: [D06F 2105/10](#) (Temperature of washing liquids; Heating means therefor)
- Note: The method of the present example essentially concerns the control of the machine per se and, as such, it should not be classified in the [D06F 35/00](#) area, which relates to methods focused on the treatment of the laundry.

References

Limiting references

This place does not cover:

Controlling processes of washer-dryers	D06F 33/50
--	----------------------------

Informative references

Attention is drawn to the following places, which may be of interest for search:

Methods for washing, rinsing or spin-drying	D06F 35/005
Controlling processes for dishwashers	A47L 15/0018

Special rules of classification

It is mandatory to classify all relevant aspects related to: purpose, manual input, automatic input, automatic output and details of the control means.

- Purpose (washing machines) [D06F 33/30](#) - [D06F 33/48](#)
- Manual Input [D06F 2101/00](#) - [D06F 2101/20](#)
- Automatic Input [D06F 2103/00](#) - [D06F 2103/70](#)
- Automatic Output [D06F 2105/00](#) - [D06F 2105/62](#)
- Details of the Control Means [D06F 34/00](#) - [D06F 34/34](#)

Note: The methods in the present area essentially concern the control of the machine per se; as such, they should not be classified in [D06F 35/005](#), [D06F 35/006](#) and [D06F 35/007](#), which relate to methods focused on the treatment of the laundry; however, in exceptional cases where both aspects are important, classification symbols belonging to both areas might be assigned.

DATE: FEBRUARY 1, 2020

PROJECT RP0608

It is noted that [D06F 35/005](#) and subgroups relate to methods for treating the laundry whereas [D06F 33/00](#) and subgroups relate to devices and methods for controlling the appliance.

D06F 33/32

Definition statement

This place covers:

The control of the individual operational steps or phases of a washing machine cycle.

D06F 33/34

Definition statement

This place covers:

The control of individual operational steps concerning the water-filling phase.

References

Informative references

Attention is drawn to the following places, which may be of interest for search:

Liquid discharge or supply arrangements	D06F 39/08
Water supply components, e.g. water supply valves	D06F 39/088

D06F 33/36

Definition statement

This place covers:

The control of individual operational steps concerning the washing phase.

D06F 33/37

Definition statement

This place covers:

The control of individual operational steps concerning the employment of detergents or additives, e.g. determining the appropriate detergent amount based on the type and amount of laundry.

References

Informative references

Attention is drawn to the following places, which may be of interest for search:

Devices for adding soap or other washing agents, components for dispensing detergent	D06F 39/02
--	----------------------------

D06F 33/38

Definition statement

This place covers:

Control methods or control arrangements concerning the rinsing phase, e.g. having the purpose of reducing the amount of water for rinsing the laundry.

Special rules of classification

Methods for rinsing the laundry are classified in [D06F 35/006](#).

D06F 33/40

Definition statement

This place covers:

Control methods or control arrangements concerning the spinning phase.

DATE: FEBRUARY 1, 2020

PROJECT RP0608

Special rules of classification

Methods for spinning the laundry are classified in [D06F 35/007](#).

D06F 33/42

Definition statement

This place covers:

Control methods or control arrangements concerning the draining phase.

References

Informative references

Attention is drawn to the following places, which may be of interest for search:

Liquid supply or discharge arrangements	D06F 39/08
Detecting faulty draining operations, e.g. filter blockage, faulty pump	D06F 39/082
Liquid discharge or recirculation arrangements, draining components	D06F 39/083

D06F 33/43

Definition statement

This place covers:

Control methods or control arrangements having the purpose of cleaning or disinfection of washing machine parts, e.g. of tubs.

References

Informative references

Attention is drawn to the following places, which may be of interest for search:

Arrangements for disinfecting the tub or the drum	D06F 35/008
---	-----------------------------

DATE: FEBRUARY 1, 2020

PROJECT RP0608

Special rules of classification

Methods for disinfecting the tub or the drum are classified under [D06F 35/008](#).

Control methods for disinfecting the clothes or the washing fluid are classified in other places of [D06F](#), such as [D06F 35/00](#); [D06F 35/001](#); [D06F 35/004](#); [D06F 37/00](#); [D06F 39/00](#).

D06F 33/44

Definition statement

This place covers:

Control methods or control arrangements concerning the operating time, e.g. reduction of overall operating time.

References

Informative references

Attention is drawn to the following places, which may be of interest for search:

Timing arrangements	D06F 34/06
Control of the operating time in laundry dryers	D06F 58/46
Time settings	D06F 2101/14
Time, e.g. duration	D06F 2103/38
Remaining operation time; Remaining operational cycles	D06F 2105/56

D06F 33/46

Definition statement

This place covers:

The control of operational steps concerning the reduction of energy or water consumption.

DATE: FEBRUARY 1, 2020

PROJECT RP0608

References**Informative references***Attention is drawn to the following places, which may be of interest for search:*

Recovery arrangements or components, e.g. for the recovery of energy or water	D06F 39/006
---	-----------------------------

D06F 33/47**Definition statement***This place covers:*

The control of operational steps concerning the prevention and early detection of potentially dangerous or abnormal working conditions that might cause damage to the user and/or to the machine, e.g. clogging of the drain pump, water leaks, electric malfunctions, etc.

References**Limiting references***This place does not cover:*

Safety arrangements	D06F 37/42
---------------------	----------------------------

D06F 33/48**Definition statement***This place covers:*

The control of operational steps to reduce and/or prevent imbalance or noise.

References**Informative references***Attention is drawn to the following places, which may be of interest for search:*

Mountings, e.g. resilient mountings, for the rotary receptacle, motor, tub, or casing; Preventing or damping vibrations	D06F 37/20
Arrangements for detecting or measuring unbalance; Preventing vibrations by regulating the speed of rotation of the drum	D06F 37/203

DATE: FEBRUARY 1, 2020

PROJECT RP0608

Damping vibrations by displacing, supplying or ejecting a material, e.g. liquid, into or from counterbalancing pockets (in machines with a receptacle rotating or oscillating about a horizontal axis)	D06F 37/225
Damping vibrations by displacing, supplying or ejecting a material, e.g. liquid, into or from counterbalancing pockets (in machines with a receptacle rotating or oscillating about a vertical axis)	D06F 37/245

D06F 33/50

Definition statement

This place covers:

The controlling processes of washer-dryers that are classified in this group and its subgroups according to their specific purpose, e.g. the optimization / improvement of the washing phase or the prevention of imbalance or noise. The same classification rules set out for [D06F 33/30](#) also apply mutatis mutandis to [D06F 33/50](#) - [D06F 33/76](#), as shown in the schematic picture below. It is noted that a symbol belonging to the aforementioned range should only be given in case the control process applies specifically to a washer-dryer, and would therefore not work for a washing machine or a laundry dryer.

The further information relating to the (manual) input and the output of these controlling processes is classified with the mandatory indexing codes and any details of the control means per se, i.e. the “hardware” is classified in the groups relating to the details of the control means (see special rules of classification for this group and its subgroups).

Concept

The following picture schematically illustrates how a controlling process of a washing machine, washer-dryer or laundry dryer is classified based on how it works: an input signal (i.e. a user input as “manual input” or an automatically detected signal as “automatic input”, e.g. by a sensors) is fed into a control unit as “control means”, which depending on the purpose of the control sends corresponding command signals to the machine components.

DATE: FEBRUARY 1, 2020

PROJECT RP0608

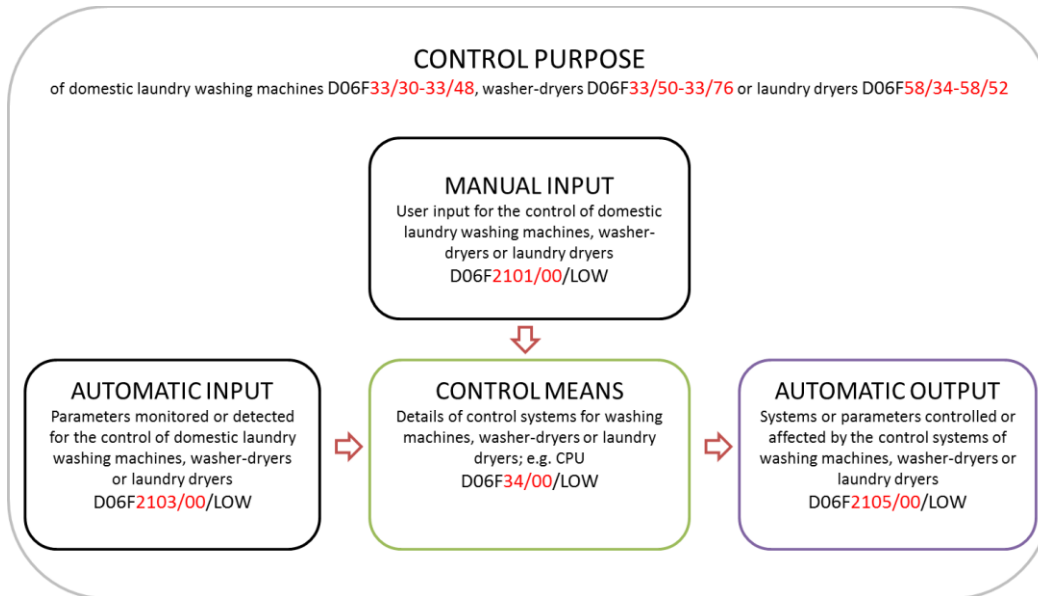

Example: washer-dryer

Washer-dryer provided with a control circuit, a control panel, an air heater and a temperature sensor for measuring the temperature of the drying air, whereby the user interface allows the user to set the maximum temperature of the drying air and the control unit is configured to regulate both the heater (e.g. by switching it ON/OFF) and the blower fan based on the temperature of the drying air.

Moreover, according to the description, the control aims to avoid damaging the laundry by overheating.

Classification of the example:

- Purpose: D06F 33/52 (Control of the operational steps, e.g. optimisation or improvement of operational steps depending on the condition of the laundry)
- Manual input: D06F 2101/18 (Target temperature for the drying process, e.g. low-temperature cycles)
- Automatic input: D06F 2103/32 (Air properties – Temperature)
- Automatic output: D06F 2105/28 (Electric heating); D06F 2105/30 (Blowers)
- Washer-dryers: D06F 25/00

Note: As a general rule, all washer-dryers are classified in D06F 25/00.

DATE: FEBRUARY 1, 2020

PROJECT RP0608

References

Informative references

Attention is drawn to the following places, which may be of interest for search:

Washing machines with receptacles, e.g. perforated, having a rotary movement, e.g. oscillatory movement, the receptacle serving both for washing and centrifugally draining and having further drying means, e.g. using hot air	D06F 25/00
---	------------

Special rules of classification

As a general rule, all washer-dryers are classified in [D06F 25/00](#).

It is mandatory to classify all relevant aspects related to: purpose, manual input, automatic input, automatic output and details of the control means.

- Purpose (washer-dryers) D06F 33/50 - D06F 33/76
- Manual Input D06F 2101/00 - D06F 2101/20
- Automatic Input D06F 2103/00 - D06F 2103/70
- Automatic Output D06F 2105/00 - D06F 2105/62
- Details of the Control Means D06F 34/00 - D06F 34/34

Note: The methods in the present area essentially concern the control of the machine per se and as such, they should not be classified in the [D06F 35/00](#) area, which relates to methods focused on the treatment of the laundry. However, in exceptional cases where both aspects are important, classification symbols belonging to both areas might be assigned.

D06F 33/52

Definition statement

This place covers:

The control of operational steps, which are focused on the condition of the laundry.

DATE: FEBRUARY 1, 2020

PROJECT RP0608

References**Informative references***Attention is drawn to the following places, which may be of interest for search:*

Washing machines with receptacles, e.g. perforated, having a rotary movement, e.g. oscillatory movement, the receptacle serving both for washing and centrifugally draining and having further drying means, e.g. using hot air	D06F 25/00
---	----------------------------

D06F 33/54**Definition statement***This place covers:*

The control of operational steps concerning the water-filling phase.

References**Informative references***Attention is drawn to the following places, which may be of interest for search:*

Washing machines with receptacles, e.g. perforated, having a rotary movement, e.g. oscillatory movement, the receptacle serving both for washing and centrifugally draining and having further drying means, e.g. using hot air	D06F 25/00
Liquid discharge or supply arrangements	D06F 39/08
Water supply components, e.g. water supply valves	D06F 39/088

D06F 33/56**Definition statement***This place covers:*

The control of operational steps concerning the washing phase.

DATE: FEBRUARY 1, 2020

PROJECT RP0608

References

Informative references

Attention is drawn to the following places, which may be of interest for search:

Washing machines with receptacles, e.g. perforated, having a rotary movement, e.g. oscillatory movement, the receptacle serving both for washing and centrifugally draining and having further drying means, e.g. using hot air	D06F 25/00
---	----------------------------

D06F 33/57

Definition statement

This place covers:

The control of individual operational steps concerning the employment of detergents or additives, e.g. determining the appropriate detergent amount based on the type and amount of the laundry load.

References

Informative references

Attention is drawn to the following places, which may be of interest for search:

Washing machines with receptacles, e.g. perforated, having a rotary movement, e.g. oscillatory movement, the receptacle serving both for washing and centrifugally draining and having further drying means, e.g. using hot air	D06F 25/00
Devices for adding soap or other washing agents, components for dispensing detergent	D06F 39/02

D06F 33/58

Definition statement

This place covers:

Control methods or control arrangements concerning the rinsing phase, e.g. reducing the amount of water for rinsing the laundry load.

DATE: FEBRUARY 1, 2020

PROJECT RP0608

References

Informative references

Attention is drawn to the following places, which may be of interest for search:

Washing machines with receptacles, e.g. perforated, having a rotary movement, e.g. oscillatory movement, the receptacle serving both for washing and centrifugally draining and having further drying means, e.g. using hot air	D06F 25/00
---	----------------------------

Special rules of classification

Methods for rinsing the laundry (i.e. wherein the focus is on the treatment of the laundry, not on the control of the machine) are classified in [D06F 35/006](#).

D06F 33/60

Definition statement

This place covers:

Control methods or control arrangements concerning the laundry-spinning phase.

References

Informative references

Attention is drawn to the following places, which may be of interest for search:

Washing machines with receptacles, e.g. perforated, having a rotary movement, e.g. oscillatory movement, the receptacle serving both for washing and centrifugally draining and having further drying means, e.g. using hot air	D06F 25/00
---	----------------------------

D06F 33/62

Definition statement

This place covers:

Control methods or control arrangements concerning the draining phase.

DATE: FEBRUARY 1, 2020

PROJECT RP0608

References

Informative references

Attention is drawn to the following places, which may be of interest for search:

Washing machines with receptacles, e.g. perforated, having a rotary movement, e.g. oscillatory movement, the receptacle serving both for washing and centrifugally draining and having further drying means, e.g. using hot air	D06F 25/00
Liquid supply or discharge arrangements	D06F 39/08
Detecting faulty draining operations, e.g. filter blockage, faulty pump	D06F 39/082
Liquid discharge or recirculation arrangements, draining components	D06F 39/083

D06F 33/63

Definition statement

This place covers:

Control methods or control arrangements aiming at steering the airflow and having purposes different from pure drying.

References

Informative references

Attention is drawn to the following places, which may be of interest for search:

Washing machines with receptacles, e.g. perforated, having a rotary movement, e.g. oscillatory movement, the receptacle serving both for washing and centrifugally draining and having further drying means, e.g. using hot air	D06F 25/00
Parameters monitored or detected for the control of domestic laundry washing machines, washer-dryers or laundry dryers - related to blowers or fans	D06F 2103/54
Parameters monitored or detected for the control of domestic laundry washing machines, washer-dryers or laundry dryers - related to air ducts, e.g. position of flow diverters	D06F 2103/56
Systems or parameters controlled or affected by the control systems of washing machines, washer-dryers or laundry dryers - airflow control means	D06F 2105/32

DATE: FEBRUARY 1, 2020

PROJECT RP0608

D06F 33/64**Definition statement***This place covers:*

Control methods or control arrangements aiming to steer the airflow and having purposes different from pure drying, wherein the air is unheated.

References**Informative references***Attention is drawn to the following places, which may be of interest for search:*

Washing machines with receptacles, e.g. perforated, having a rotary movement, e.g. oscillatory movement, the receptacle serving both for washing and centrifugally draining and having further drying means, e.g. using hot air	D06F 25/00
Parameters monitored or detected for the control of domestic laundry washing machines, washer-dryers or laundry dryers - related to blowers or fans	D06F 2103/54
Parameters monitored or detected for the control of domestic laundry washing machines, washer-dryers or laundry dryers - related to air ducts, e.g. position of flow diverters	D06F 2103/56
Systems or parameters controlled or affected by the control systems of washing machines, washer-dryers or laundry dryers - air flow control means	D06F 2105/32

D06F 33/65**Definition statement***This place covers:*

Control methods or control arrangements for washer-dryers having the purpose of conditioning or finishing the laundry, e.g. using a laundry-conditioning agent like water, steam, perfume, starch.

DATE: FEBRUARY 1, 2020

PROJECT RP0608

References

Informative references

Attention is drawn to the following places, which may be of interest for search:

Washing machines with receptacles, e.g. perforated, having a rotary movement, e.g. oscillatory movement, the receptacle serving both for washing and centrifugally draining and having further drying means, e.g. using hot air	D06F 25/00
Steam generating arrangements	D06F 39/008
Laundry conditioning arrangements	D06F 58/203
Steam generators per se	F22B 1/28

D06F 33/68

Definition statement

This place covers:

Control methods or control arrangements for washer-dryers having the purpose of controlling the sequence of washing and drying operations.

References

Informative references

Attention is drawn to the following places, which may be of interest for search:

Washing machines with receptacles, e.g. perforated, having a rotary movement, e.g. oscillatory movement, the receptacle serving both for washing and centrifugally draining and having further drying means, e.g. using hot air	D06F 25/00
Timing arrangements	D06F 34/06
Changing sequence of operational steps; carrying out additional operational steps; Modifying operational steps, e.g. by extending duration of steps	D06F 2105/52

DATE: FEBRUARY 1, 2020

PROJECT RP0608

D06F 33/69

Definition statement

This place covers:

Control methods or control arrangements for cleaning or disinfecting washer-dryer parts, e.g. the condenser, air duct, etc.

References

Informative references

Attention is drawn to the following places, which may be of interest for search:

Washing machines with receptacles, e.g. perforated, having a rotary movement, e.g. oscillatory movement, the receptacle serving both for washing and centrifugally draining and having further drying means, e.g. using hot air	D06F 25/00
Arrangements for disinfecting the tub or the drum	D06F 35/008
Lint collecting arrangements	D06F 58/22

Special rules of classification

Control methods for disinfecting the clothes or the washing fluid are generally classified in [D06F 35/00](#); [D06F 35/001](#); [D06F 35/004](#); [D06F 37/00](#); [D06F 39/00](#) and, if applicable, also in the group concerning the item on which the disinfecting device is mounted (e.g. the detergent drawer, the gasket, the water pump, the tub etc.).

Cleaning of the lint collecting arrangements is classified in [D06F 58/45](#).

Methods for disinfecting the tub or the drum are classified in [D06F 35/008](#).

D06F 33/70

Definition statement

This place covers:

Control methods or control arrangements concerning to the operating time, e.g. reduction of overall operating time.

DATE: FEBRUARY 1, 2020

PROJECT RP0608

References

Informative references

Attention is drawn to the following places, which may be of interest for search:

Washing machines with receptacles, e.g. perforated, having a rotary movement, e.g. oscillatory movement, the receptacle serving both for washing and centrifugally draining and having further drying means, e.g. using hot air	D06F 25/00
Timing arrangements	D06F 34/06
Control of the operating time for laundry dryers	D06F 58/46
Time settings	D06F 2101/14
Time, e.g. duration	D06F 2103/38
Remaining operation time; Remaining operational cycles	D06F 2105/56

D06F 33/72

Definition statement

This place covers:

The control of individual operational steps concerning the reduction of energy or water consumption.

References

Informative references

Attention is drawn to the following places, which may be of interest for search:

Washing machines with receptacles, e.g. perforated, having a rotary movement, e.g. oscillatory movement, the receptacle serving both for washing and centrifugally draining and having further drying means, e.g. using hot air	D06F 25/00
Recovery arrangements or components, e.g. for the recovery of energy or water	D06F 39/006

DATE: FEBRUARY 1, 2020

PROJECT RP0608

D06F 33/74**Definition statement***This place covers:*

The control of individual operational steps concerning the prevention and early detection of potentially dangerous or abnormal working conditions, which might cause damage to the user and/or to the machine, e.g. clogging of the drain pump, water leaks, electric malfunctions, etc.

References**Limiting references***This place does not cover:*

Safety arrangements for washing machines	D06F 37/42
--	----------------------------

Informative references*Attention is drawn to the following places, which may be of interest for search:*

Washing machines with receptacles, e.g. perforated, having a rotary movement, e.g. oscillatory movement, the receptacle serving both for washing and centrifugally draining and having further drying means, e.g. using hot air	D06F 25/00
---	----------------------------

D06F 33/76**Definition statement***This place covers:*

The control of individual operational steps for reducing and/or preventing imbalance or noise.

References**Informative references***Attention is drawn to the following places, which may be of interest for search:*

Washing machines with receptacles, e.g. perforated, having a rotary movement, e.g. oscillatory movement, the receptacle	D06F 25/00
---	----------------------------

serving both for washing and centrifugally draining and having further drying means, e.g. using hot air	
Mountings, e.g. resilient mountings, for the rotary receptacle, motor, tub, or casing; Preventing or damping vibrations	D06F 37/20
Arrangements for detecting or measuring unbalance; preventing vibrations by regulating the speed of rotation of the drum	D06F 37/203
Damping vibrations by displacing, supplying or ejecting a material, e.g. liquid, into or from counterbalancing pockets (in machines with a receptacle rotating or oscillating about a horizontal axis)	D06F 37/225
Damping vibrations by displacing, supplying or ejecting a material, e.g. liquid, into or from counterbalancing pockets (in machines with a receptacle rotating or oscillating about a vertical axis)	D06F 37/245

D06F 34/00

Definition statement

This place covers:

Details of control systems for washing machines, washer-dryers or laundry dryers. See also definition statement and examples shown under D06F33/30 and D06F33/50.

Illustrative example of subject matter classified in this group.

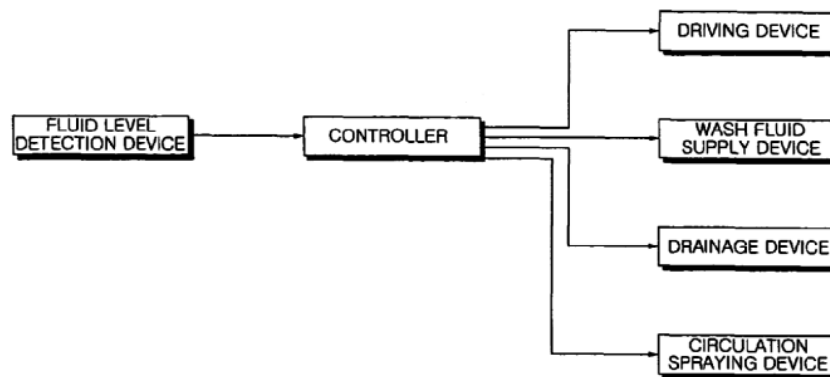

D06F 34/04

Definition statement

This place covers:

Details of control systems for washing machines, washer-dryers or laundry dryers, relating to wired signal transfer or data transmission arrangements.

D06F 34/05

Definition statement

This place covers:

Details of control systems for washing machines, washer-dryers or laundry dryers, relating to wireless signal transfer or data transmission arrangements, e.g. WIFI, Bluetooth, RF, NFC, optic, etc.

Illustrative example of subject matter classified in this group.

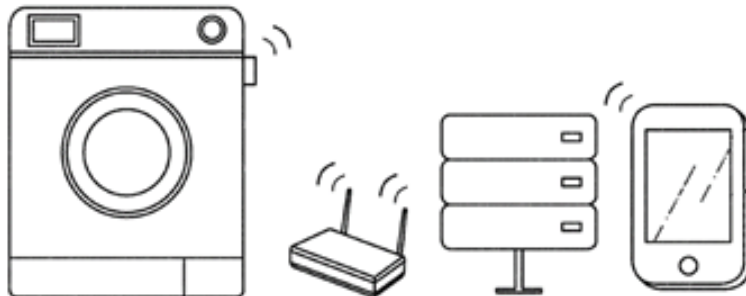

D06F 34/06

Definition statement

This place covers:

Details of control systems for washing machines, washer-dryers or laundry dryers, concerning timing.

References

Informative references

Attention is drawn to the following places, which may be of interest for search:

User input for the control of domestic laundry washing machines, washer-dryers or laundry dryers – time settings	D06F 2101/14
Parameters monitored or detected for the control of domestic laundry washing machines, washer-dryers or laundry dryers - time, e.g. duration	D06F 2103/38
Systems or parameters controlled or affected by the control systems of washing machines, washer-dryers or laundry dryers - starting machine operation, e.g. delayed start or re-start after power cut	D06F 2105/50
Systems or parameters controlled or affected by the control systems of washing machines, washer-dryers or laundry dryers - changing sequence of operational steps; carrying out additional operational steps; modifying operational steps, e.g. by extending duration of steps	D06F 2105/52
Systems or parameters controlled or affected by the control systems of washing machines, washer-dryers or laundry dryers - remaining operation time; remaining operational cycles	D06F 2105/56

D06F 34/08

Definition statement

This place covers:

Illustrative example of subject matter classified in this group.

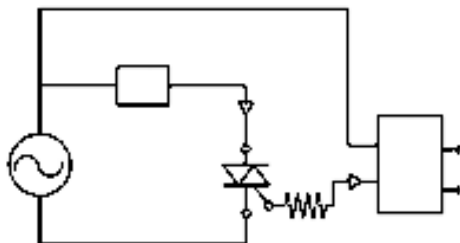

D06F 34/10

Definition statement

This place covers:

Illustrative example of subject matter classified in this group.

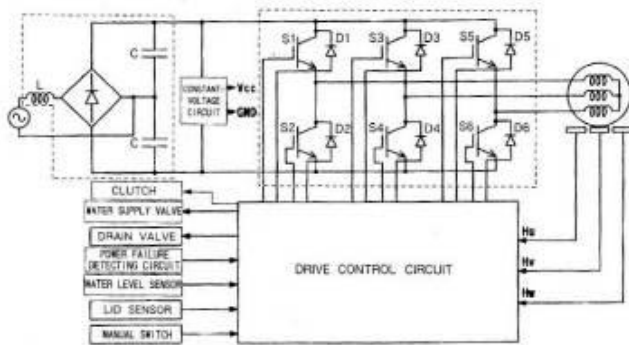

D06F 34/14

Definition statement

This place covers:

Details of control systems for washing machines, washer-dryers or laundry dryers relating to the detection of specific parameters.

D06F 34/16

Definition statement

This place covers:

Details of control systems for washing machines, washer-dryers or laundry dryers relating to the detection of imbalance.

Illustrative example of subject matter classified in this group.

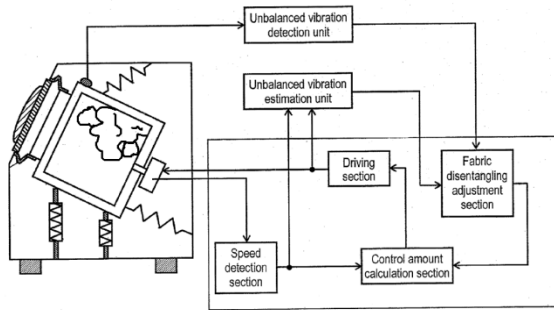

References

Informative references

Attention is drawn to the following places, which may be of interest for search:

Mountings, e.g. resilient mountings, for the rotary receptacle, motor, tub, or casing; Preventing or damping vibrations	D06F 37/20
Arrangements for detecting or measuring unbalance; Preventing vibrations by regulating the speed of rotation of the drum	D06F 37/203
Damping vibrations by displacing, supplying or ejecting a material, e.g. liquid, into or from counterbalancing pockets (in machines with a receptacle rotating or oscillating about a horizontal axis)	D06F 37/225
Damping vibrations by displacing, supplying or ejecting a material, e.g. liquid, into or from counterbalancing pockets (in machines with a receptacle rotating or oscillating about a vertical axis)	D06F 37/245

D06F 34/18

Definition statement

This place covers:

Details of control systems for washing machines, washer-dryers or laundry dryers, relating to the detection of the condition of the laundry, comprising both the sensors and their control arrangements.

Illustrative example of subject matter classified in this group.

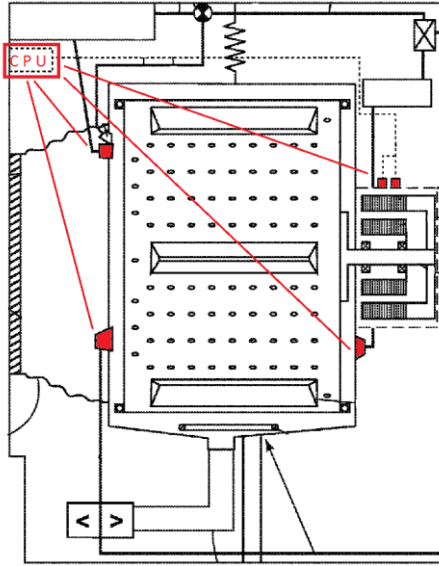

References

Informative references

Attention is drawn to the following places, which may be of interest for search:

Parameters monitored or detected for the control of domestic laundry washing machines, washer-dryers or laundry dryers - characteristics of laundry or load	D06F 2103/02
Parameters monitored or detected for the control of domestic laundry washing machines, washer-dryers or laundry dryers - quantity, e.g. weight or variation of weight	D06F 2103/04
Parameters monitored or detected for the control of domestic laundry washing machines, washer-dryers or laundry dryers - type or material	D06F 2103/06
Parameters monitored or detected for the control of domestic laundry washing machines, washer-dryers or laundry dryers - humidity / temperature	D06F 2103/08 - D06F 2103/12

D06F 34/20

Definition statement

This place covers:

Details of control systems for washing machines, washer-dryers or laundry dryers, relating to the detection of specific parameters of constructional components of the appliance, e.g. checking the position of the door, lint filter, detergent drawer, etc.

Illustrative example of subject matter classified in this group.

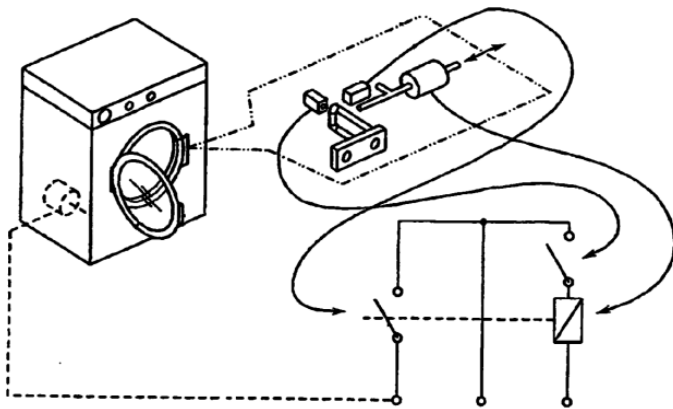

References

Informative references

Attention is drawn to the following places, which may be of interest for search:

Security means for doors of drums rotating about a horizontal or inclined axis	D06F 37/10
Security means for doors of drums rotating about a vertical axis	D06F 37/18
Security means for doors of tubs	D06F 37/28
Driving arrangements for automatic drum positioning	D06F 37/302
Safety arrangements, e.g. for stopping rotation of the receptacle upon opening of the casing door	D06F 37/42
Devices for adding soap or other washing agent	D06F 39/02
Filtering arrangements	D06F 39/10
Casings	D06F 39/12
Securing means for doors of casings	D06F 39/14

General details of domestic laundry dryers	D06F 58/20
Lint collecting arrangements	D06F 58/22
Opening or locking status of doors	D06F 2103/40

Special rules of classification

Details concerning safety arrangements are classified in [D06F 37/42](#); safety arrangements for preventing water damage in [D06F 39/081](#); preventing and responding to irregular working conditions in [D06F 33/47](#).

D06F 34/22

Definition statement

This place covers:

Details of control systems for washing machines or washer-dryers, relating to the detection of the condition of the washing liquid, e.g. devices for measuring and/or controlling the detergent concentration, water hardness, etc., comprising both the sensors and their control arrangements.

Illustrative example of subject matter classified in this group.

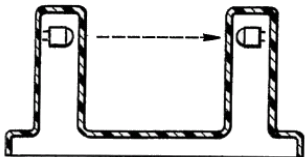

D06F 34/24

Definition statement

This place covers:

Details of control systems for washing machines or washer-dryers, relating to the detection of the temperature of the washing liquid, e.g. thermostats, etc., comprising both the sensors and their control arrangements.

Illustrative example of subject matter classified in this group.

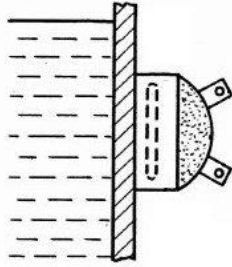

References

Informative references

Attention is drawn to the following places, which may be of interest for search:

Temperature measuring arrangements for dishwashers
--

A47L15/4287

D06F 34/26

Definition statement

This place covers:

Details of control systems for washer-dryers or laundry dryers, relating to the detection of the condition of the drying air, e.g. humidity sensors, temperature sensors, pressure sensors, etc., comprising both the sensors and their control arrangements.

Illustrative example of subject matter classified in this group.

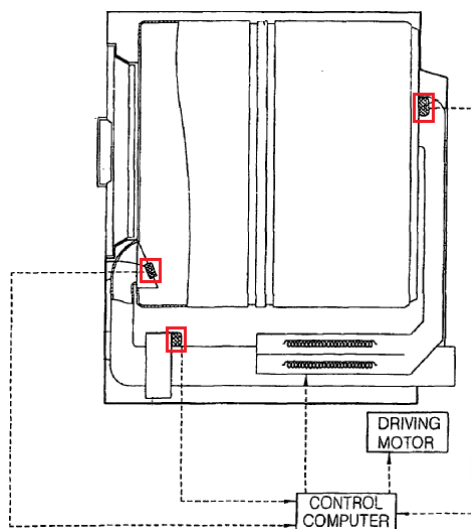

DATE: FEBRUARY 1, 2020

PROJECT RP0608

D06F 34/28

Definition statement

This place covers:

Details of control systems for washer-dryers or laundry dryers, relating to arrangements for program selection and/ or visualization.

Illustrative example of subject matter classified in this group.

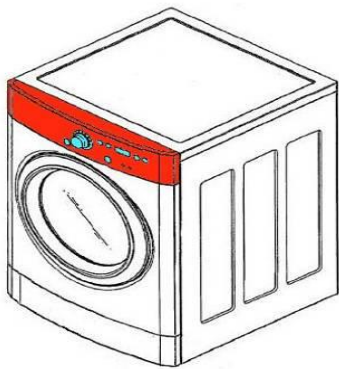

References

Informative references

Attention is drawn to the following places, which may be of interest for search:

Drying processes in domestic laundry dryers	D06F 58/30
Arrangements for program selection in dishwashers, e.g. control panels	A47L 15/4293
Control devices for stoves, e.g. control panels	F24C 7/082
Arrangement or mounting of control or safety devices for refrigerators	F25D 29/00
Alarm-clock-controlled mechanisms for coffee or tea making apparatus	A47J 31/52
Electric programme-control systems in general	G05B 19/02
Electric programme-control systems using selector switches	G05B 19/10
Arrangements for transmitting signals characterised by the use of a wireless link	G08C 17/00
Circuit arrangements for providing remote indication of network conditions	H02J 13/00

Input and output arrangements for electrical digital data processing	G06F 3/00
Indicating or measuring liquid level, in general	G01F 23/00
Optical indicating means for TV sets and radios	H03J 1/04
Digitisers, e.g. for touch screens or touch pads, characterised by the transducing means	G06F 3/041
Light guides	G02B 6/00

D06F 34/30

Definition statement

This place covers:

Illustrative example of subject matter classified in this group.

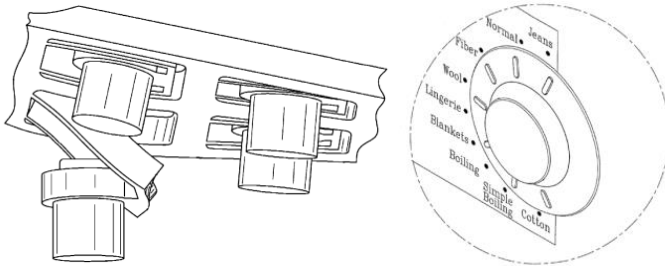

D06F 34/32

Definition statement

This place covers:

Illustrative example of subject matter classified in this group.

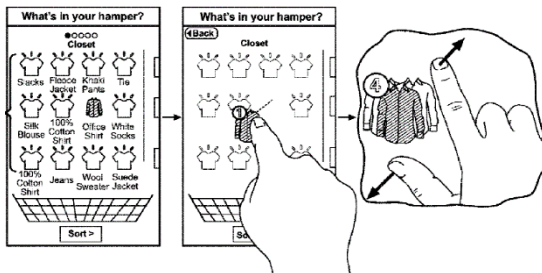

D06F 34/34

Definition statement

This place covers:

Illustrative example of subject matter classified in this group.

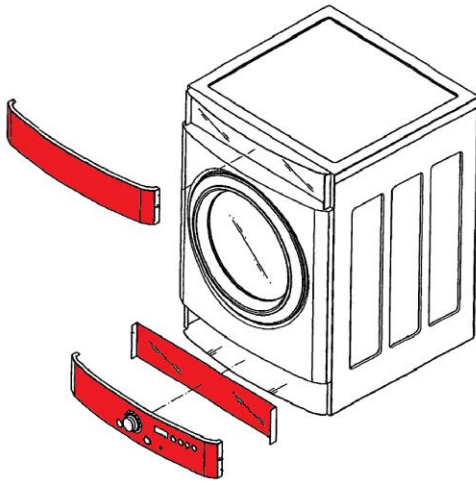

D06F 58/30

Definition statement

This place covers:

Laundry drying processes per se, i.e. machine working methods characterized by several laundry treating steps.

It is noted that in this group the focus is set on the treating process the laundry undergoes.

Illustrative example of subject matter classified in this group.

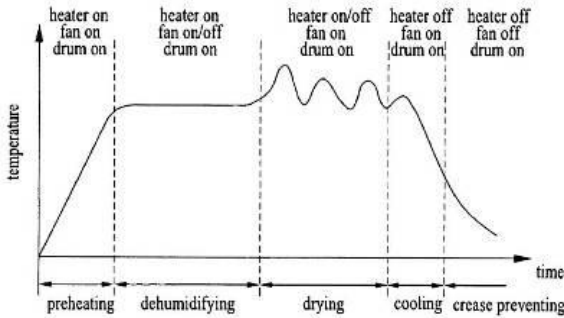

The above diagram represents a typical drying method for laundry dryers, in which several laundry treating steps are performed, for example during the drying process the heater and the blower fan are subsequently turned ON/OFF while the drum is rotated.

References

Limiting references

This place does not cover:

Controlling a series of operations in domestic laundry dryers	D06F 58/32
---	----------------------------

Informative references

Attention is drawn to the following places, which may be of interest for search:

Controlling processes for dishwashers	A47L 15/0018
Methods for washing, rinsing or spin-drying	D06F 35/005
General details of domestic laundry dryers	D06F 58/20

D06F 58/32

Definition statement

This place covers:

General control aspects that are not covered by [D06F 58/34](#) - [D06F 58/52](#).

D06F 58/34

Definition statement

This place covers:

The controlling processes of laundry dryers that are classified in this group and its subgroups according to their specific purpose, e.g. the optimization / improvement of the drying phase or the prevention of laundry ignition.

The further information relating to the (manual) input and the output of these controlling processes is classified with the mandatory indexing codes and any details of the control means per se, i.e. the “hardware” is classified in the groups relating to the details of the control means (see special rules of classification for this group and its subgroups).

Concept

The following picture schematically illustrates how a controlling process of a washing machine, washer-dryer or laundry dryer is classified based on how it works. An input signal (i.e. a user input as “manual input” or an automatically detected signal as “automatic input, e.g. by a sensors) is fed into a control unit as “control means” which depending on the purpose of the control sends corresponding command signals to the machine components.

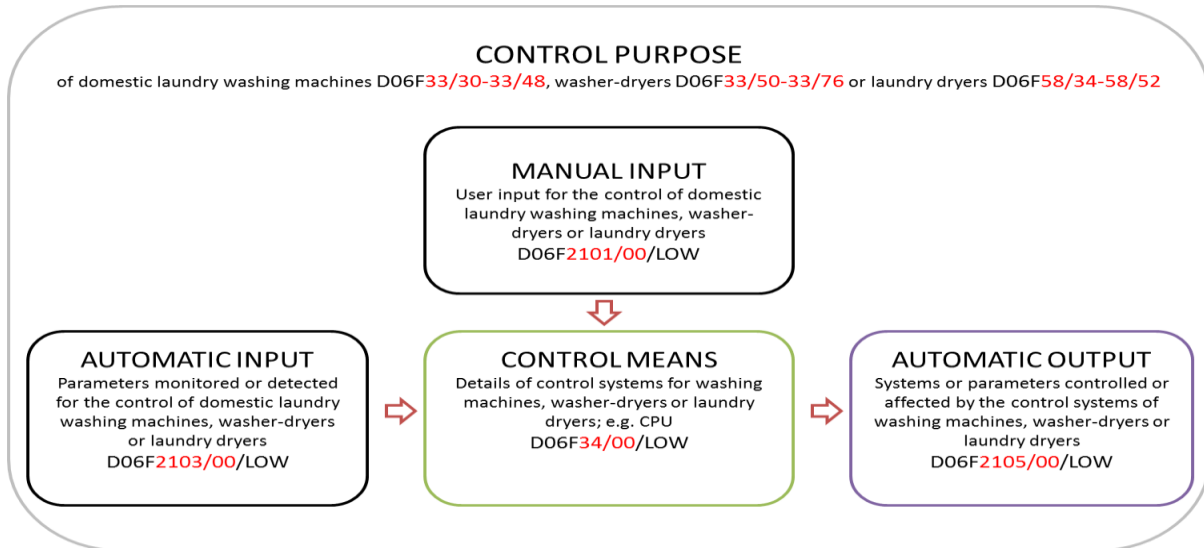

A controlling process of a laundry treating apparatus (e.g. a laundry dryer) has a specific “control purpose” and implies the presence of a “control means” (e.g. a CPU), whereby the control means is usually a control unit which comprises a user interface

DATE: FEBRUARY 1, 2020

PROJECT RP0608

(e.g. a control panel) and several sensors for the automatic detection of e.g. air temperature, laundry humidity, liquid level in the condensed water tank, etc.

Moreover, the control unit is usually configured to perform actions as “automatic output” (e.g. switching a heater ON/OFF, regulating the blower fan speed, etc.), depending on the purpose of the control and based on the input of the user and/or the signals provided by the sensors.

First example: laundry dryer - control method

Control method for a laundry dryer employing a control unit adapted to detect the temperature of the drying air and to switch the fan speed and the heater ON/OFF based on the target humidity of the laundry load, as input by the user, such as to reduce the operating time.

Classification of the example:

- Purpose: [D06F 33/70](#) (Control of the operating time)
- Manual input: [D06F 2101/16](#) (Target humidity for the drying process)
- Automatic input: [D06F 2103/32](#) (Air properties – temperature)
- Automatic output: [D06F 2105/28](#) (Electric heating); [D06F 2105/30](#) (Blowers)

Second example: washer-dryer

Washer-dryer provided with a control circuit, a control panel, an air heater and a temperature sensor for measuring the temperature of the drying air, whereby the user interface allows the user to set the maximum temperature of the drying air, and the control unit is configured to regulate the heater (e.g. by switching it ON/OFF) and the blower fan based on the temperature of the drying air. The control aims to avoid damaging the laundry by overheating.

Classification of the example:

- Purpose: [D06F 33/52](#) (Control of the operational steps, e.g. optimisation or improvement of operational steps depending on the condition of the laundry)
- Manual input: [D06F 2101/18](#) (Target temperature for the drying process, e.g. low-temperature cycles)
- Automatic input: [D06F 2103/32](#) (Air properties – Temperature)
- Automatic output: [D06F 2105/28](#) (Electric heating); [D06F 2105/30](#) (Blowers)
- Note: All washer-dryers have to be also classified, as a general rule, in [D06F 25/00](#).

Special rules of classification

It is compulsory to classify also all relevant aspects related to the Purpose, Manual Input, Automatic Input, Automatic Output and Details of the control means.

- Purpose D06F58/34- D06F58/52
- Manual Input D06F2101/00- D06F2101/20
- Automatic Input D06F2103/00- D06F2103/70
- Automatic Output D06F2105/00- D06F2105/62
- Details of the Control Means D06F34/00- D06F34/34

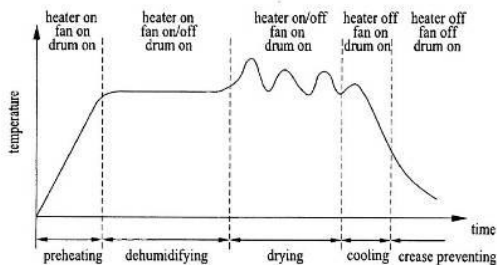

The above diagram represents a typical drying method for laundry dryers, belonging to [D06F 58/30](#) in which, during the drying process, the heater and the blower fan are subsequently turned ON/OFF while the drum is rotated. It is noted that [D06F 58/30](#) relates to methods for treating the laundry whereas [D06F 58/34](#) and subgroups relate to devices for controlling the appliance (i.e. the focus is set on the treating process the laundry undergoes).

D06F 58/36

Definition statement

This place covers:

The control of individual operational steps, which are focused on the condition of the laundry.

D06F 58/38

Definition statement

This place covers:

The control of individual operational steps, which are focused on the achievement of one or more target drying parameters.

DATE: FEBRUARY 1, 2020

PROJECT RP0608

D06F 58/40

Definition statement

This place covers:

The control of individual operational steps, which are focused on the initial heating phase.

D06F 58/42

Definition statement

This place covers:

Control methods or control arrangements having the purpose of steering and/or optimizing the air flow, wherein the air is unheated.

D06F 58/44

Definition statement

This place covers:

Control methods or control arrangements of laundry dryers having the purpose of conditioning or finishing the laundry, e.g. using a laundry-conditioning agent like water, steam, perfume, starch.

References

Informative references

Attention is drawn to the following places, which may be of interest for search:

Steam generating arrangements	D06F 39/008
Laundry conditioning arrangements	D06F 58/203
Steam generators per se	F22B 1/28

DATE: FEBRUARY 1, 2020

PROJECT RP0608

D06F 58/45

Definition statement

This place covers:

Control methods or control arrangements having the purpose of cleaning or disinfecting of laundry dryer components, e.g. of the lint filter, condenser, air duct, etc.

References

Informative references

Attention is drawn to the following places, which may be of interest for search:

Control of cleaning or disinfection of washer-dryer parts, e.g. of washer-dryer tubs	D06F 33/69
Methods for disinfecting the tub or the drum for washing machines	D06F 35/008
Laundry conditioning arrangements	D06F 58/203
Lint collecting arrangements	D06F 58/22

Special rules of classification

Arrangements for disinfecting the tub or the drum are classified under [D06F 35/008](#).

Devices for collecting lint or fluff are classified under [D06F 58/22](#).

D06F 58/46

Definition statement

This place covers:

Control methods concerning the operating time, e.g. reduction of overall operating time.

References

Informative references

Attention is drawn to the following places, which may be of interest for search:

Timing arrangements	D06F 34/06
Control of the operating time of washer-dryers	D06F 33/70
Time settings	D06F 2101/14
Time, e.g. duration	D06F 2103/38
Remaining operation time; Remaining operational cycles	D06F 2105/56

DATE: FEBRUARY 1, 2020

PROJECT RP0608

D06F 58/48**Definition statement***This place covers:*

The control of individual operational steps concerning the reduction of energy consumption.

References**Informative references***Attention is drawn to the following places, which may be of interest for search:*

Control of the energy or water consumption (washer-dryers)	D06F 33/72
Recovery arrangements or components, e.g. for the recovery of energy or water	D06F 39/006

D06F 58/50**Definition statement***This place covers:*

The control of individual operational steps concerning the prevention and early detection of potentially dangerous or abnormal working conditions that might cause damage to the user and/or to the machine, e.g. clogging of the lint filter, laundry ignition, electric malfunctions, etc.

References**Informative references***Attention is drawn to the following places, which may be of interest for search:*

Control of washer-dryers responding to irregular working conditions, e.g. malfunctioning of pumps	D06F 33/74
---	----------------------------

DATE: FEBRUARY 1, 2020

PROJECT RP0608

D06F 58/52**Definition statement***This place covers:*

The control of individual operational steps to reduce and/or prevent imbalance or noise.

References**Informative references***Attention is drawn to the following places, which may be of interest for search:*

Mountings, e.g. resilient mountings, for the rotary receptacle, motor, tub, or casing; Preventing or damping vibrations, for washing machines	D06F 37/20
Arrangements for detecting or measuring unbalance; preventing vibrations by regulating the speed of rotation of the drum, for washing machines	D06F 37/203
Damping vibrations by displacing, supplying or ejecting a material, e.g. liquid, into or from counterbalancing pockets, for washing machines with a receptacle rotating or oscillating about a horizontal axis	D06F 37/225
Damping vibrations by displacing, supplying or ejecting a material, e.g. liquid, into or from counterbalancing pockets for washing machines with a receptacle rotating or oscillating about a vertical axis	D06F 37/245

2. A. DEFINITIONS (modified)

D06F

Definition statement

Replace: The entire third bulleted statement (Controlling...driers (cf. D06F 58/28)) in the Definition statement section with the following:

- Controlling or regulating domestic laundry dryers (cf. [D06F 58/30](#)).

Replace: The last two statements beginning with “The Indexing Codes ...of variables” in the Definition statement section with the following three paragraphs.

The Indexing Codes [D06F 2101/00](#) - [D06F 2101/20](#) cover user input for the control of domestic laundry washing machines, washer-dryers or laundry dryers.

The Indexing Codes [D06F 2103/00](#) - [D06F 2103/70](#) cover parameters monitored or detected for the control of domestic laundry washing machines, washer-dryers or laundry dryers.

The Indexing Codes [D06F 2105/00](#) - [D06F 2105/62](#) cover systems or parameters controlled or affected by the control systems of washing machines, washer-dryers or laundry dryers.

Relationships with other classification places

Insert: The following as the first sentence in the Relationships with other classification places section.

This subclass does not cover treatment of textiles by purely chemical means, which is covered by subclasses [D06L](#) and [D06M](#).

Replace: In the Relationships with other classification places section, in the paragraph: “For example, if an application relates to a jog dial...”, the symbol “D06F 39/005” with the following symbol.

[D06F 34/28](#)

DATE: FEBRUARY 1, 2020

PROJECT RP0608

References

Insert: The following new reference section: Application-oriented references.

Application-oriented references

Examples of places where the subject matter of this place is covered when specially adapted, used for a particular purpose, or incorporated in a larger system:

Apparatus for blocking, pressing, steaming or stretching hats	A42C
---	------

Informative references

Insert: The following new row in the existing Informative references table.

Treating textile materials by liquids, gases or vapors	D06B
--	------

Delete: The entire existing Special rules of classification section.

D06F 21/00

Definition statement

Delete: From the Definition statement section, the existing image shown below.

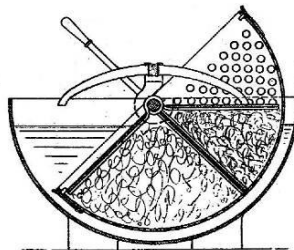

Informative references

Replace: The two existing rows with the following revised rows.

Washing machines with receptacles moving bodily about an axis	D06F 27/00
Programme-control aspects of washing machines	D06F 33/00

Synonyms and Keywords

Replace: The existing Synonyms and Keywords table with the following new text.

In patent documents, the following words/expressions are often used as synonyms:

- receptacle and drum
- enclosing receptacle and tub
- lifters and ribs

D06F 23/00

Definition statement

Delete: From the Definition statement section, the existing statement and image shown below.

Illustrative example of subject matter classified in this group.

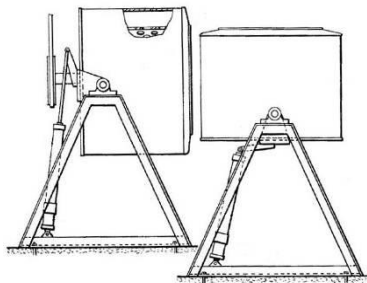

Insert: The following new References/Limiting references section.

References

Limiting references

This place does not cover:

Washing machines of this type with further drying means	D06F 25/00
Programme-control aspects	D06F 33/00

Synonyms and Keywords

Replace: The existing text in Synonyms and Keywords section with the following new text.

In patent documents, the following words/expressions are often used as synonyms:

- tub and drum

CPC NOTICE OF CHANGES XXX

DATE: FEBRUARY 1, 2020

PROJECT RP0608

2. B. DEFINITIONS QUICK FIX

<u>Symbol</u>	<u>Location of change</u> (e.g., section title)	<u>Existing reference symbol or text</u>	<u>Action; New symbol; New text</u>
D06F 5/00			<p><u>Insert</u> the following <u>new</u> Informative references section.</p> <p>References <i>Informative references</i> <i>Attention is drawn to the following places, which may be of interest for search:</i></p> <p>Brushes A46B</p>
D06F 5/00			<p><u>Insert</u> the following <u>new</u> Limiting references section.</p> <p>References <i>Limiting references</i> <i>This place does not cover:</i></p> <p>Hand rubbing appliances D06F 3/00</p>
D06F 13/00			<p><u>Insert</u> the following <u>new</u> Limiting references section.</p> <p>References <i>Limiting references</i> <i>This place does not cover:</i></p> <p>Plungers or the like adapted for removable mounting on receptacles D06F 5/04</p>
D06F 13/00			<p><u>Insert</u> the following <u>new</u> Informative references section.</p> <p>References <i>Informative references</i> <i>Attention is drawn to the following places, which may be of interest for search:</i></p>

CPC NOTICE OF CHANGES XXX

DATE: FEBRUARY 1, 2020

PROJECT RP0608

<u>Symbol</u>	<u>Location of change</u> (e.g., section title)	<u>Existing reference symbol or text</u>	<u>Action; New symbol; New text</u>
			Washing devices adapted to be used independently of any particular receptacle D06F 7/00
D06F 15/00			<p><u>Insert</u> the following <u>new</u> Limiting references section.</p> <p>References Limiting references <i>This place does not cover:</i></p> <p>Plungers or the like adapted for removable mounting on receptacles D06F 5/04</p> <p>Mangle-type washing machines D06F 11/00</p>
D06F 17/00			<p><u>Insert</u> the following <u>new</u> Informative references section.</p> <p>References Informative references <i>Attention is drawn to the following places, which may be of interest for search:</i></p> <p>Washing devices adapted to be used independently of any particular receptacle D06F 7/00</p> <p>Using vibrations for washing purposes D06F 19/00</p>
D06F17/02			<p><u>Insert</u> the following <u>new</u> Limiting references section.</p> <p>Limiting references <i>This place does not cover:</i></p> <p>Washing action effected solely by water jets D06F 17/04</p>

CPC NOTICE OF CHANGES XXX

DATE: FEBRUARY 1, 2020

PROJECT RP0608

<u>Symbol</u>	<u>Location of change</u> (e.g., section title)	<u>Existing reference symbol or text</u>	<u>Action; New symbol; New text</u>
D06F 18/00			<p><u>Insert</u> the following <u>new</u> Limiting references section.</p> <p>Limiting references <i>This place does not cover:</i></p> <p>Control of washing or of washing and drying D06F 33/00, D06F 34/00</p> <p>Domestic laundry dryers D06F 58/00</p>
D06F 19/00			<p><u>Insert</u> the following <u>new</u> Informative references section.</p> <p>References Informative references <i>Attention is drawn to the following places, which may be of interest for search:</i></p> <p>Devices of the vibrator type adapted to be used independently of any particular receptacle D06F 7/04</p>
D06F 25/00			<p><u>Insert</u> the following <u>new</u> Limiting references section.</p> <p>Limiting references <i>This place does not cover:</i></p> <p>Control of washing or of washing and drying D06F 33/00, D06F 34/00</p> <p>Domestic laundry dryers D06F 58/00</p>

CPC NOTICE OF CHANGES XXX

DATE: FEBRUARY 1, 2020

PROJECT RP0608

<u>Symbol</u>	<u>Location of change</u> (e.g., section title)	<u>Existing reference symbol or text</u>	<u>Action; New symbol; New text</u>
D06F 29/02			<p><u>Insert</u> the following <u>new</u> Limiting references section.</p> <p>Limiting references <i>This place does not cover:</i></p> <p>Combination with roller wringer D06F 45/12</p>
D06F 33/02	Definition		Delete the entire Definition.
D06F 37/00			<p><u>Insert</u> the following <u>new</u> Informative references section.</p> <p>References Informative references <i>Attention is drawn to the following places, which may be of interest for search:</i></p> <p>Details of more general application D06F 39/00</p> <p>Details concerning drying only D06F 58/00</p>
D06F 37/20	Informative references		<p><u>Insert</u> the following <u>new</u> row in the Informative references section</p> <p>Counterweights mounted to the tub or mountings therefor D06F 37/265</p>
D06F 37/203	Limiting references	Spin profiles D06F 35/007	<p><u>Replace</u> the existing row with the following <u>new</u> row.</p> <p>Sensing vibrations to control introduction of counterbalancing liquid D06F 37/225, D06F 37/245</p>

CPC NOTICE OF CHANGES XXX

DATE: FEBRUARY 1, 2020

PROJECT RP0608

<u>Symbol</u>	<u>Location of change</u> (e.g., section title)	<u>Existing reference symbol or text</u>	<u>Action; New symbol; New text</u>
D06F 37/203			<p><u>Insert</u> the following <u>new</u> Informative references section.</p> <p>References Informative references <i>Attention is drawn to the following places, which may be of interest for search:</i></p> <p>Spin profiles D06F 35/007</p>
D06F 37/30			<p><u>Insert</u> the following <u>new</u> Limiting references section.</p> <p>Limiting references <i>This place does not cover:</i></p> <p>Control circuits or arrangements D06F 34/08</p>
D06F 39/00			<p><u>Insert</u> the following <u>new</u> Special rules of classification section.</p> <p>Details of washing machines specifically adapted to a single type of the machines covered by groups D06F 9/00 - D06F 27/00 are covered by the group corresponding to the machine type.</p>
D06F 39/00	Definition statement		<p><u>Insert</u> the following text as the <u>first</u> statement in the Definition statement section.</p> <p>General details of washing machines, i.e. details that can be applied to several types of the machines covered by groups D06F 9/00 - D06F 27/00</p>

CPC NOTICE OF CHANGES XXX

DATE: FEBRUARY 1, 2020

PROJECT RP0608

<u>Symbol</u>	<u>Location of change</u> (e.g., section title)	<u>Existing reference symbol or text</u>	<u>Action; New symbol; New text</u>
D06F 39/00			<p><u>Insert</u> the following <u>new</u> Limiting references section.</p> <p><i>Limiting references</i> <i>This place does not cover:</i></p> <p>Control of operations performed in washing machines D06F 33/00</p> <p>Details of control systems for washing machines D06F 34/00</p>
D06F 39/002	Definition		Delete the entire Definition.
D06F 39/003	Definition		Delete the entire Definition.
D06F 39/004	Definition		Delete the entire Definition.
D06F 39/005	Definition		Delete the entire Definition.
D06F 39/08			<p><u>Insert</u> the following <u>new</u> Limiting references section.</p> <p><i>Limiting references</i> <i>This place does not cover:</i></p> <p>Supply of soap or other washing agents D06F 39/02</p>
D06F 39/087	Informative references	Water supply with cold and hot water D06F 2204/088	<p><u>Replace</u> the existing row in the Informative references table with the following <u>new</u> row:</p> <p>From separate hot and cold water inlets D06F 2105/04</p>
D06F 39/12	Limiting references	Tubs D06F 37/26	<u>Delete</u> the entire Limiting references section.

CPC NOTICE OF CHANGES XXX

DATE: FEBRUARY 1, 2020

PROJECT RP0608

<u>Symbol</u>	<u>Location of change</u> (e.g., section title)	<u>Existing reference symbol or text</u>	<u>Action; New symbol; New text</u>
D06F 39/12	Informative references		<u>Insert</u> the following <u>new</u> row in the Informative references section. Tubs D06F 37/26
D06F 39/14	Limiting references	Doors hinged to the drum D06F 37/10 Doors hinged to the tub D06F 37/28	<u>Delete</u> the entire Limiting references section.
D06F 39/14	Informative references		<u>Insert</u> the following two <u>new</u> rows in the Informative references table. Doors hinged to the drum D06F 37/10 Doors hinged to the tub D06F 37/28
D06F 43/00			<u>Insert</u> the following <u>new</u> Limiting references section. <i>Limiting references</i> <i>This place does not cover:</i> Washing machines D06F 9/00 – D06F 41/00
D06F 43/08			<u>Insert</u> the following <u>new</u> Informative references section. <i>References</i> <i>Informative references</i> <i>Attention is drawn to the following places, which may be of interest for search:</i> Separate apparatus for purifying dry-cleaning solvents B01D

CPC NOTICE OF CHANGES XXX

DATE: FEBRUARY 1, 2020

PROJECT RP0608

<u>Symbol</u>	<u>Location of change</u> (e.g., section title)	<u>Existing reference symbol or text</u>	<u>Action; New symbol; New text</u>
D06F 45/14			<p><u>Insert</u> the following <u>new</u> Informative references section.</p> <p>References Informative references <i>Attention is drawn to the following places, which may be of interest for search:</i></p> <p>Combined with tables A47B</p>
D06F 49/00			<p><u>Insert</u> the following <u>new</u> Informative references section.</p> <p>References Informative references <i>Attention is drawn to the following places, which may be of interest for search:</i></p> <p>Centrifuges in general B04B</p>
D06F 49/06			<p><u>Insert</u> the following <u>new</u> Informative references section.</p> <p>References Informative references <i>Attention is drawn to the following places, which may be of interest for search:</i></p> <p>Damping vibrations in general F16F</p>
D06F 53/00			<p><u>Insert</u> the following <u>new</u> Informative references section.</p> <p>References Informative references <i>Attention is drawn to the following places, which may be of interest for search:</i></p>

CPC NOTICE OF CHANGES XXX

DATE: FEBRUARY 1, 2020

PROJECT RP0608

<u>Symbol</u>	<u>Location of change</u> (e.g., section title)	<u>Existing reference symbol or text</u>	<u>Action; New symbol; New text</u>
			<p>Supports or holders specially adapted or mounted for storing and repeatedly paying-out and restoring lengths of lines B65H 75/34</p> <p>Ropes, cables D07B</p>
D06F 53/00			<p><u>Insert</u> the following <u>new</u> Limiting references section.</p> <p>Limiting references <i>This place does not cover:</i></p> <p>Drying frames incorporating clothes-lines D06F 57/00</p>
D06F 53/04			<p><u>Insert</u> the following <u>new</u> Informative references section.</p> <p>References Informative references <i>Attention is drawn to the following places, which may be of interest for search:</i></p> <p>Poles in general E04H</p>
D06F 57/00			<p><u>Insert</u> the following <u>new</u> Limiting references section.</p> <p>Limiting references <i>This place does not cover:</i></p> <p>In combination with means for heating or positive air circulation D06F 58/00</p> <p>Adapted to retain the shape of particular articles being dried D06F 59/00</p>

CPC NOTICE OF CHANGES XXX

DATE: FEBRUARY 1, 2020

PROJECT RP0608

<u>Symbol</u>	<u>Location of change</u> (e.g., section title)	<u>Existing reference symbol or text</u>	<u>Action; New symbol; New text</u>
D06F 57/00	Informative references		<p><u>Insert</u> the following two <u>new</u> rows in the Informative references table.</p> <p>Clothing hangers, e.g. suit hangers A47G 25/14</p> <p>Drying in general F26B</p>
D06F 57/02			<p><u>Insert</u> the following <u>new</u> Informative references section.</p> <p>References Informative references <i>Attention is drawn to the following places, which may be of interest for search:</i></p> <p>Sockets or holders for poles or posts E04H 12/22</p>
D06F 58/00			<p><u>Insert</u> the following <u>new</u> Informative references section.</p> <p>References Informative references <i>Attention is drawn to the following places, which may be of interest for search:</i></p> <p>Drying in general F26B</p>
D06F 58/04			<p><u>Insert</u> the following <u>new</u> Limiting references section.</p> <p>Limiting references <i>This place does not cover:</i></p> <p>Controlling or regulating devices D06F 34/00</p>

CPC NOTICE OF CHANGES XXX

DATE: FEBRUARY 1, 2020

PROJECT RP0608

<u>Symbol</u>	<u>Location of change</u> (e.g., section title)	<u>Existing reference symbol or text</u>	<u>Action; New symbol; New text</u>
D06F 58/10	Limiting references	Clothes dryers having a rotating drum D06F 58/02	<u>Delete</u> the entire Limiting references section.
D06F 58/10			<u>Insert</u> the following <u>new</u> Informative references section. References Informative references <i>Attention is drawn to the following places, which may be of interest for search:</i> Clothes dryers having a rotating drum D06F 58/02
D06F 58/16			<u>Insert</u> the following <u>new</u> Limiting references section. Limiting references <i>This place does not cover:</i> Supports adapted to retain the shape of particular articles being dried D06F 59/00
D06F 58/20			<u>Insert</u> the following <u>new</u> Limiting references section. Limiting references <i>This place does not cover:</i> Supports adapted to retain the shape of particular articles being dried D06F 59/00
D06F 58/26			<u>Insert</u> the following <u>new</u> Limiting references section. Limiting references <i>This place does not cover:</i>

CPC NOTICE OF CHANGES XXX

DATE: FEBRUARY 1, 2020

PROJECT RP0608

<u>Symbol</u>	<u>Location of change</u> (e.g., section title)	<u>Existing reference symbol or text</u>	<u>Action; New symbol; New text</u>
			Detachable or door-mounted drying arrangements for washing machines D06F 58/18
D06F 58/28			Delete the entire Definition.
D06F 59/00			<u>Insert</u> the following <u>new</u> Informative references section. References Informative references <i>Attention is drawn to the following places, which may be of interest for search:</i> Apparatuses for changing the form and size of hats A42C 3/00
D06F 67/00			<u>Insert</u> the following <u>new</u> Limiting references section. Limiting references <i>This place does not cover:</i> Coverings or pads for ironing or pressing members D06F 83/00
D06F 71/00			<u>Insert</u> the following <u>new</u> Application-oriented references section. Application-oriented references <i>Examples of places where the subject matter of this place is covered when specially adapted, used for a particular purpose, or incorporated in a larger system:</i> Devices, for household use, for cold-pressing garments A47G

CPC NOTICE OF CHANGES XXX

DATE: FEBRUARY 1, 2020

PROJECT RP0608

<u>Symbol</u>	<u>Location of change</u> (e.g., section title)	<u>Existing reference symbol or text</u>	<u>Action; New symbol; New text</u>
D06F 71/00			<p><u>Insert</u> the following <u>new</u> Informative references section.</p> <p>References Informative references <i>Attention is drawn to the following places, which may be of interest for search:</i></p> <p>Smoothing by cold rolling between two or more co-operating rollers D06F 45/00</p>
D06F 71/02			<p><u>Insert</u> the following <u>new</u> Limiting references section.</p> <p>Limiting references <i>This place does not cover:</i></p> <p>Apparatuses wherein one or more of the pressing elements is moved laterally between successive pressing operations D06F 71/08</p>
D06F 71/04	Limiting references		<p><u>Insert</u> the following <u>new</u> Limiting references section.</p> <p>Limiting references <i>This place does not cover:</i></p> <p>Apparatuses wherein one or more of the pressing elements is moved laterally between successive pressing operations D06F 71/08</p>
D06F 71/16			<p><u>Insert</u> the following <u>new</u> Limiting references section.</p> <p>References Limiting references <i>This place does not cover:</i></p>

CPC NOTICE OF CHANGES XXX

DATE: FEBRUARY 1, 2020

PROJECT RP0608

<u>Symbol</u>	<u>Location of change</u> (e.g., section title)	<u>Existing reference symbol or text</u>	<u>Action; New symbol; New text</u>
			For pressing particular garments or parts thereof D06F 71/18
D06F 71/30			<p><u>Insert</u> the following <u>new</u> Limiting references section.</p> <p>Limiting references <i>This place does not cover:</i></p> <p>For pressing particular garments or parts thereof D06F 71/18</p>
D06F 71/36			<p><u>Insert</u> the following <u>new</u> Limiting references section.</p> <p>Limiting references <i>This place does not cover:</i></p> <p>For use in pressing particular garments or parts thereof D06F 71/18</p> <p>Coverings or pads therefor D06F 83/00</p>
D06F 71/38			<p><u>Insert</u> the following <u>new</u> Limiting references section.</p> <p>Limiting references <i>This place does not cover:</i></p> <p>Feeding by lateral movement of pressing elements D06F 71/08</p>
D06F 73/00			<p><u>Insert</u> the following <u>new</u> Limiting references section.</p> <p>Limiting references <i>This place does not cover:</i></p> <p>Combined with external pressure means D06F 71/00</p>

CPC NOTICE OF CHANGES XXX

DATE: FEBRUARY 1, 2020

PROJECT RP0608

<u>Symbol</u>	<u>Location of change</u> (e.g., section title)	<u>Existing reference symbol or text</u>	<u>Action; New symbol; New text</u>
D06F 73/00			<p><u>Insert</u> the following rows in the existing Informative references section.</p> <p>References Informative references <i>Attention is drawn to the following places, which may be of interest for search:</i></p> <p>Stretchers for drying purposes D06F 59/00</p> <p>Combined with external pressure means D06F 71/00</p> <p>Stretchers for use with presses D06F 71/40</p> <p>Dress-forms for the tailoring trade A41H</p> <p>Garment stretchers without the application of heat A47G 25/00</p>
D06F 75/06			<p><u>Insert</u> the following <u>new</u> Limiting references section.</p> <p>Limiting references <i>This place does not cover:</i></p> <p>Attachments for converting hand irons to steam irons D06F 75/32</p>
D06F75/10			<p><u>Insert</u> the following <u>new</u> Limiting references section.</p> <p>Limiting references <i>This place does not cover:</i></p> <p>Attachments for converting hand irons to steam irons D06F 75/32</p>

CPC NOTICE OF CHANGES XXX

DATE: FEBRUARY 1, 2020

PROJECT RP0608

<u>Symbol</u>	<u>Location of change</u> (e.g., section title)	<u>Existing reference symbol or text</u>	<u>Action; New symbol; New text</u>
D06F75/22			<p><u>Insert</u> the following <u>new</u> Limiting references section.</p> <p>Limiting references <i>This place does not cover:</i></p> <p>Hand irons heated by electricity with means for supplying steam to the article being ironed D06F 75/10</p>
D06F 75/24	Informative references		<p><u>Insert</u> the following <u>new</u> row in the Informative references table.</p> <p>Electric heating in general H05B</p>
D06F 75/26			<p><u>Insert</u> the following <u>new</u> Informative references section.</p> <p>References Informative references <i>Attention is drawn to the following places, which may be of interest for search:</i></p> <p>Thermally actuated switches H01H</p>
D06F 75/38			<p><u>Insert</u> the following <u>new</u> Limiting references section.</p> <p>Limiting references <i>This place does not cover:</i></p> <p>Arrangements for discharging the steam to the article being ironed D06F 75/20</p>
D06F 79/04			<p><u>Insert</u> the following <u>new</u> Informative references section.</p> <p>References Informative references <i>Attention is drawn to the following places, which may be of interest for search:</i></p>

CPC NOTICE OF CHANGES XXX

DATE: FEBRUARY 1, 2020

PROJECT RP0608

<u>Symbol</u>	<u>Location of change</u> (e.g., section title)	<u>Existing reference symbol or text</u>	<u>Action; New symbol; New text</u>
			Stoves in general F24
D06F 81/00			<p><u>Insert</u> the following <u>new</u> Limiting references section.</p> <p><i>Limiting references</i> <i>This place does not cover:</i></p> <p>Coverings or pads therefor D06F 83/00</p> <p>Kitchen cabinets with ironing boards movable outwards to a position of use A47B 77/10</p>
D06F 81/00	Informative references		<p><u>Insert</u> the following two <u>new</u> rows in the Informative references table.</p> <p>Tables in general A47B</p> <p>Ironing boards combined with ladders E06C</p>
D06F 87/00	Limiting references		<p><u>Insert</u> the following <u>new</u> Limiting references section.</p> <p><i>Limiting references</i> <i>This place does not cover:</i></p> <p>Devices used in combination with a laundry dryer D06F 58/203</p> <p>Apparatuses for smoothing or removing creases from garments or other textile articles by formers, cores, stretchers or internal frames, with the application of heat or steam D06F 73/00</p>

CPC NOTICE OF CHANGES XXX

DATE: FEBRUARY 1, 2020

PROJECT RP0608

<u>Symbol</u>	<u>Location of change</u> (e.g., section title)	<u>Existing reference symbol or text</u>	<u>Action; New symbol; New text</u>
D06F 95/00			<p><u>Insert</u> the following <u>new</u> Informative references section.</p> <p>References <i>Informative references</i> <i>Attention is drawn to the following places, which may be of interest for search:</i></p> <p>Laundries as buildings E04H</p>
D06F 95/00			<p><u>Insert</u> the following <u>new</u> Limiting references section.</p> <p>Limiting references <i>This place does not cover:</i></p> <p>Washing installations comprising an assembly of several washing machines or washing units D06F 31/00</p>

NOTES:

- The table above is used for corrections or modifications to existing definitions, e.g. delete an entire definition or part thereof; propose new wording or modify wording of a section, change the symbol the definition is associated with, change or delete a reference symbol, etc.
- Do not delete (F) symbol definitions.

CPC NOTICE OF CHANGES XXX

DATE: FEBRUARY 1, 2020

PROJECT RP0608

3. REVISION CONCORDANCE LIST (RCL)

Type*	<u>From CPC Symbol (existing)</u>	<u>To CPC Symbol(s)</u>
C	D06F 18/00	D06F 18/00, D06F 31/00, D06F 31/005, D06F 33/00, D06F 33/04, D06F 33/06, D06F 33/08, D06F 33/10, D06F 33/30, D06F 33/32, D06F 33/34, D06F 33/36, D06F 33/37, D06F 33/38, D06F 33/40, D06F 33/42, D06F 33/43, D06F 33/44, D06F 33/46, D06F 33/47, D06F 33/48, D06F 33/50, D06F 33/52, D06F 33/54, D06F 33/56, D06F 33/57, D06F 33/58, D06F 33/60, D06F 33/62, D06F 33/63, D06F 33/64, D06F 33/65, D06F 33/68, D06F 33/69, D06F 33/70, D06F 33/72, D06F 33/74, D06F 33/76, D06F 34/00, D06F 34/04, D06F 34/05, D06F 34/06, D06F 34/08, D06F 34/10, D06F 34/14, D06F 34/16, D06F 34/18, D06F 34/20, D06F 34/22, D06F 34/24, D06F 34/26, D06F 34/28, D06F 34/30, D06F 34/32, D06F 34/34, D06F 37/42, D06F 2101/00, D06F 2101/02, D06F 2101/04, D06F 2101/06, D06F 2101/10, D06F 2101/12, D06F 2101/14, D06F 2101/16, D06F 2101/18, D06F 2101/20, D06F 2103/00, D06F 2103/02, D06F 2103/04, D06F 2103/06, D06F 2103/08, D06F 2103/10, D06F 2103/12, D06F 2103/14, D06F 2103/16, D06F 2103/18, D06F 2103/20, D06F 2103/22, D06F 2103/24, D06F 2103/26, D06F 2103/28, D06F 2103/30, D06F 2103/32, D06F 2103/34, D06F 2103/36, D06F 2103/38, D06F 2103/40, D06F 2103/42, D06F 2103/44, D06F 2103/46, D06F 2103/48, D06F 2103/50, D06F 2103/52, D06F 2103/54, D06F 2103/56, D06F 2103/58, D06F 2103/60, D06F 2103/62, D06F 2103/64, D06F 2103/66, D06F 2103/68, D06F 2103/70, D06F 2105/50, D06F 2105/52, D06F 2105/54, D06F 2105/56, D06F 2105/58, D06F 2105/60, D06F 2105/62
C	D06F 19/00	D06F 19/00, D06F 2103/66
C	D06F 25/00	D06F 25/00, D06F 34/00, D06F 34/04, D06F 34/05, D06F 34/06, D06F 34/08, D06F 34/10, D06F 34/14, D06F 34/16, D06F 34/18, D06F 34/20, D06F 34/22, D06F 34/24, D06F 34/26, D06F 34/28, D06F 34/30, D06F 34/32, D06F 34/34, D06F 37/42, D06F 2101/00, D06F 2101/02, D06F 2101/04, D06F 2101/06, D06F 2101/10, D06F 2101/12, D06F 2101/14, D06F 2101/16, D06F 2101/18, D06F 2101/20, D06F 2103/00, D06F 2103/02, D06F 2103/04, D06F 2103/06, D06F 2103/08, D06F 2103/20, D06F 2103/22, D06F 2103/24, D06F 2103/26, D06F 2103/28, D06F 2103/30, D06F 2103/32, D06F 2103/34, D06F 2103/36, D06F 2103/38, D06F 2103/40, D06F 2103/42, D06F 2103/44, D06F 2103/46, D06F 2103/48, D06F 2103/50, D06F 2103/52, D06F 2103/54, D06F 2103/56, D06F 2103/58, D06F 2103/60, D06F 2103/62, D06F 2103/64, D06F 2103/66, D06F 2103/68, D06F 2103/70, D06F 2105/50, D06F 2105/52, D06F 2105/54, D06F 2105/56, D06F 2105/58, D06F 2105/60, D06F 2105/62
C	D06F 33/00	D06F 33/00, D06F 33/30, D06F 33/32, D06F 33/34, D06F 33/36, D06F 33/37, D06F 33/38, D06F 33/40, D06F 33/42, D06F 33/43, D06F 33/44, D06F 33/46, D06F 33/47, D06F 33/48, D06F 33/50, D06F 33/52, D06F 33/54, D06F 33/56, D06F 33/57, D06F 33/58, D06F 33/60, D06F 33/62, D06F 33/63, D06F 33/64, D06F 33/65, D06F 33/68, D06F 33/69, D06F 33/70, D06F 33/72, D06F 33/74, D06F 33/76, D06F 34/00, D06F 34/04, D06F 34/05, D06F 34/06, D06F 34/08, D06F 34/10, D06F 34/14, D06F 34/16, D06F 34/18, D06F 34/20, D06F 34/22, D06F 34/24, D06F 34/26, D06F 34/28,

CPC NOTICE OF CHANGES XXX

DATE: FEBRUARY 1, 2020

PROJECT RP0608

<u>Type*</u>	<u>From CPC Symbol (existing)</u>	<u>To CPC Symbol(s)</u>
		D06F 34/30, D06F 34/32, D06F 34/34, D06F 37/42, D06F 58/32, D06F 58/34, D06F 58/36, D06F 58/38, D06F 58/40, D06F 58/42, D06F 58/44, D06F 58/45, D06F 58/46, D06F 58/48, D06F 58/50, D06F 58/52, D06F 2101/00, D06F 2101/02, D06F 2101/04, D06F 2101/06, D06F 2101/10, D06F 2101/12, D06F 2101/14, D06F 2101/16, D06F 2101/18, D06F 2101/20, D06F 2103/00, D06F 2103/02, D06F 2103/04, D06F 2103/06, D06F 2103/08, D06F 2103/10, D06F 2103/12, D06F 2103/14, D06F 2103/16, D06F 2103/18, D06F 2103/20, D06F 2103/22, D06F 2103/24, D06F 2103/26, D06F 2103/28, D06F 2103/30, D06F 2103/32, D06F 2103/34, D06F 2103/36, D06F 2103/38, D06F 2103/40, D06F 2103/42, D06F 2103/44, D06F 2103/46, D06F 2103/48, D06F 2103/50, D06F 2103/52, D06F 2103/54, D06F 2103/56, D06F 2103/58, D06F 2103/60, D06F 2103/62, D06F 2103/64, D06F 2103/66, D06F 2103/68, D06F 2103/70, D06F 2105/00, D06F 2105/02, D06F 2105/04, D06F 2105/06, D06F 2105/08, D06F 2105/10, D06F 2105/12, D06F 2105/14, D06F 2105/16, D06F 2105/18, D06F 2105/20, D06F 2105/22, D06F 2105/24, D06F 2105/26, D06F 2105/28, D06F 2105/30, D06F 2105/32, D06F 2105/34, D06F 2105/36, D06F 2105/38, D06F 2105/40, D06F 2105/42, D06F 2105/44, D06F 2105/46, D06F 2105/48, D06F 2105/50, D06F 2105/52, D06F 2105/54, D06F 2105/56, D06F 2105/58, D06F 2105/60, D06F 2105/62
D	D06F 33/02	<Administrative transfer to D06F 33/00>
Q	D06F 34/18	D06F 34/18, D06F 2103/02, D06F 2103/04, D06F 2103/06, D06F 2103/08
Q	D06F 34/22	D06F 34/22, D06F 2103/20, D06F 2103/22
Q	D06F 34/28	D06F 34/28, D06F 34/30, D06F 34/32, D06F 34/34, D06F 2101/00, D06F 2101/02, D06F 2101/04, D06F 2101/06, D06F 2101/10, D06F 2101/12, D06F 2101/14, D06F 2101/16, D06F 2101/18, D06F 2101/20, D06F 2103/68, D06F 2103/70, D06F 2105/50, D06F 2105/52, D06F 2105/54, D06F 2105/56, D06F 2105/58, D06F 2105/60, D06F 2105/62
C	D06F 35/00	D06F 35/00, D06F 34/00, D06F 34/04, D06F 34/05, D06F 34/06, D06F 34/08, D06F 34/10, D06F 34/14, D06F 34/16, D06F 34/18, D06F 34/20, D06F 34/22, D06F 34/24, D06F 34/26, D06F 34/28, D06F 34/30, D06F 34/32, D06F 34/34, D06F 2101/00, D06F 2101/02, D06F 2101/04, D06F 2101/06, D06F 2101/10, D06F 2101/12, D06F 2101/14, D06F 2101/16, D06F 2101/18, D06F 2101/20, D06F 2103/02, D06F 2103/04, D06F 2103/06, D06F 2103/08, D06F 2103/20, D06F 2103/22, D06F 2103/66, D06F 2103/68, D06F 2103/70, D06F 2105/50, D06F 2105/52, D06F 2105/54, D06F 2105/56, D06F 2105/58, D06F 2105/60, D06F 2105/62
C	D06F 35/001	D06F 35/001, D06F 34/00, D06F 34/04, D06F 34/05, D06F 34/06, D06F 34/08, D06F 34/10, D06F 34/14, D06F 34/16, D06F 34/18, D06F 34/20, D06F 34/22, D06F 34/24, D06F 34/26, D06F 34/28, D06F 34/30, D06F 34/32, D06F 34/34, D06F 2101/00, D06F 2101/02, D06F 2101/04, D06F 2101/06, D06F 2101/10, D06F 2101/12, D06F 2101/14, D06F 2101/16, D06F 2101/18, D06F 2101/20, D06F 2103/02, D06F 2103/04, D06F 2103/06, D06F 2103/08, D06F 2103/20, D06F 2103/22, D06F 2103/66, D06F 2103/68,

CPC NOTICE OF CHANGES XXX

DATE: FEBRUARY 1, 2020

PROJECT RP0608

Type*	From CPC Symbol (existing)	To CPC Symbol(s)
		D06F 2103/70, D06F 2105/50, D06F 2105/52, D06F 2105/54, D06F 2105/56, D06F 2105/58, D06F 2105/60, D06F 2105/62
C	D06F 35/002	D06F 35/002, D06F 34/00, D06F 34/04, D06F 34/05, D06F 34/06, D06F 34/08, D06F 34/10, D06F 34/14, D06F 34/16, D06F 34/18, D06F 34/20, D06F 34/22, D06F 34/24, D06F 34/26, D06F 34/28, D06F 34/30, D06F 34/32, D06F 34/34, D06F 2101/00, D06F 2101/02, D06F 2101/04, D06F 2101/06, D06F 2101/10, D06F 2101/12, D06F 2101/14, D06F 2101/16, D06F 2101/18, D06F 2101/20, D06F 2103/02, D06F 2103/04, D06F 2103/06, D06F 2103/08, D06F 2103/20, D06F 2103/22, D06F 2103/68, D06F 2103/70, D06F 2105/50, D06F 2105/52, D06F 2105/54, D06F 2105/56, D06F 2105/58, D06F 2105/60, D06F 2105/62
C	D06F 35/003	D06F 35/003, D06F 34/00, D06F 34/04, D06F 34/05, D06F 34/06, D06F 34/08, D06F 34/10, D06F 34/14, D06F 34/16, D06F 34/18, D06F 34/20, D06F 34/22, D06F 34/24, D06F 34/26, D06F 34/28, D06F 34/30, D06F 34/32, D06F 34/34, D06F 2101/00, D06F 2101/02, D06F 2101/04, D06F 2101/06, D06F 2101/10, D06F 2101/12, D06F 2101/14, D06F 2101/16, D06F 2101/18, D06F 2101/20, D06F 2103/02, D06F 2103/04, D06F 2103/06, D06F 2103/08, D06F 2103/20, D06F 2103/22, D06F 2103/66, D06F 2103/68, D06F 2103/70, D06F 2105/50, D06F 2105/52, D06F 2105/54, D06F 2105/56, D06F 2105/58, D06F 2105/60, D06F 2105/62
C	D06F 35/004	D06F 35/004, D06F 34/00, D06F 34/04, D06F 34/05, D06F 34/06, D06F 34/08, D06F 34/10, D06F 34/14, D06F 34/16, D06F 34/18, D06F 34/20, D06F 34/22, D06F 34/24, D06F 34/26, D06F 34/28, D06F 34/30, D06F 34/32, D06F 34/34, D06F 2101/00, D06F 2101/02, D06F 2101/04, D06F 2101/06, D06F 2101/10, D06F 2101/12, D06F 2101/14, D06F 2101/16, D06F 2101/18, D06F 2101/20, D06F 2103/02, D06F 2103/04, D06F 2103/06, D06F 2103/08, D06F 2103/20, D06F 2103/22, D06F 2103/66, D06F 2103/68, D06F 2103/70, D06F 2105/50, D06F 2105/52, D06F 2105/54, D06F 2105/56, D06F 2105/58, D06F 2105/60, D06F 2105/62
C	D06F 35/005	D06F 35/005, D06F 33/36, D06F 33/38, D06F 33/56, D06F 33/58, D06F 34/00, D06F 34/04, D06F 34/05, D06F 34/06, D06F 34/08, D06F 34/10, D06F 34/14, D06F 34/16, D06F 34/18, D06F 34/20, D06F 34/22, D06F 34/24, D06F 34/26, D06F 34/28, D06F 34/30, D06F 34/32, D06F 34/34, D06F 2101/00, D06F 2101/02, D06F 2101/04, D06F 2101/06, D06F 2101/10, D06F 2101/12, D06F 2101/14, D06F 2101/16, D06F 2101/18, D06F 2101/20, D06F 2103/02, D06F 2103/04, D06F 2103/06, D06F 2103/08, D06F 2103/20, D06F 2103/22, D06F 2103/66, D06F 2103/68, D06F 2103/70, D06F 2105/50, D06F 2105/52, D06F 2105/54, D06F 2105/56, D06F 2105/58, D06F 2105/60, D06F 2105/62
C	D06F 35/006	D06F 35/006, D06F 33/36, D06F 33/38, D06F 33/56, D06F 33/58, D06F 34/00, D06F 34/04, D06F 34/05, D06F 34/06, D06F 34/08, D06F 34/10, D06F 34/14, D06F 34/16, D06F 34/18, D06F 34/20, D06F 34/22, D06F 34/24, D06F 34/26, D06F 34/28, D06F 34/30, D06F 34/32, D06F 34/34, D06F 2101/00, D06F 2101/02, D06F 2101/04, D06F 2101/06, D06F 2101/10, D06F 2101/12, D06F 2101/14, D06F 2101/16, D06F 2101/18, D06F 2101/20, D06F 2103/02, D06F 2103/04, D06F 2103/06, D06F 2103/08,

CPC NOTICE OF CHANGES XXX

DATE: FEBRUARY 1, 2020

PROJECT RP0608

Type*	From CPC Symbol (existing)	To CPC Symbol(s)
		D06F 2103/20, D06F 2103/22, D06F 2103/68, D06F 2103/70, D06F 2105/50, D06F 2105/52, D06F 2105/54, D06F 2105/56, D06F 2105/58, D06F 2105/60, D06F 2105/62
C	D06F 35/007	D06F 35/007, D06F 33/40, D06F 33/60, D06F 34/00, D06F 34/04, D06F 34/05, D06F 34/06, D06F 34/08, D06F 34/10, D06F 34/14, D06F 34/16, D06F 34/18, D06F 34/20, D06F 34/22, D06F 34/24, D06F 34/26, D06F 34/28, D06F 34/30, D06F 34/32, D06F 34/34, D06F 2101/00, D06F 2101/02, D06F 2101/04, D06F 2101/06, D06F 2101/10, D06F 2101/12, D06F 2101/14, D06F 2101/16, D06F 2101/18, D06F 2101/20, D06F 2103/02, D06F 2103/04, D06F 2103/06, D06F 2103/08, D06F 2103/20, D06F 2103/22, D06F 2103/24, D06F 2103/68, D06F 2103/70, D06F 2105/50, D06F 2105/52, D06F 2105/54, D06F 2105/56, D06F 2105/58, D06F 2105/60, D06F 2105/62
C	D06F 35/008	D06F 35/008, D06F 33/43, D06F 33/69, D06F 34/00, D06F 34/04, D06F 34/05, D06F 34/06, D06F 34/08, D06F 34/10, D06F 34/14, D06F 34/16, D06F 34/18, D06F 34/20, D06F 34/22, D06F 34/24, D06F 34/26, D06F 34/28, D06F 34/30, D06F 34/32, D06F 34/34, D06F 2101/00, D06F 2101/02, D06F 2101/04, D06F 2101/06, D06F 2101/10, D06F 2101/12, D06F 2101/14, D06F 2101/16, D06F 2101/18, D06F 2101/20, D06F 2103/02, D06F 2103/04, D06F 2103/06, D06F 2103/08, D06F 2103/20, D06F 2103/22, D06F 2103/68, D06F 2103/70, D06F 2105/50, D06F 2105/52, D06F 2105/54, D06F 2105/56, D06F 2105/58, D06F 2105/60, D06F 2105/62
C	D06F 37/00	D06F 37/00, D06F 34/00, D06F 34/04, D06F 34/05, D06F 34/06, D06F 34/08, D06F 34/10, D06F 34/14, D06F 34/16, D06F 34/18, D06F 34/20, D06F 34/22, D06F 34/24, D06F 34/26, D06F 34/28, D06F 34/30, D06F 34/32, D06F 34/34, D06F 2101/00, D06F 2101/02, D06F 2101/04, D06F 2101/06, D06F 2101/10, D06F 2101/12, D06F 2101/14, D06F 2101/16, D06F 2101/18, D06F 2101/20, D06F 2103/02, D06F 2103/04, D06F 2103/06, D06F 2103/08, D06F 2103/20, D06F 2103/22, D06F 2103/68, D06F 2103/70, D06F 2105/50, D06F 2105/52, D06F 2105/54, D06F 2105/56, D06F 2105/58, D06F 2105/60, D06F 2105/62
C	D06F 37/10	D06F 37/10, D06F 34/20, D06F 2103/40, D06F 2105/44
C	D06F 37/18	D06F 37/18, D06F 34/20, D06F 2103/40, D06F 2105/44
F	D06F 37/203	D06F 33/48, D06F 33/76, D06F 34/08, D06F 34/16, D06F 2103/26, D06F 2103/46
C	D06F 37/22	D06F 37/22, D06F 33/48, D06F 33/76, D06F 34/08, D06F 34/16
C	D06F 37/225	D06F 37/225, D06F 33/48, D06F 33/76, D06F 34/08, D06F 34/16
C	D06F 37/24	D06F 37/24, D06F 33/48, D06F 33/76, D06F 34/08, D06F 34/16
C	D06F 37/245	D06F 37/245, D06F 33/48, D06F 33/76, D06F 34/08, D06F 34/16
C	D06F 37/28	D06F 37/28, D06F 34/20
C	D06F 37/30	D06F 37/30, D06F 34/08, D06F 34/10
C	D06F 37/302	D06F 37/302, D06F 34/20, D06F 2103/40, D06F 2105/44
C	D06F 37/304	D06F 37/304, D06F 34/08, D06F 34/10, D06F 2103/24, D06F 2103/46, D06F 2105/46, D06F 2105/48
F	D06F 37/306	D06F 34/08, D06F 34/10

CPC NOTICE OF CHANGES XXX

DATE: FEBRUARY 1, 2020

PROJECT RP0608

<u>Type*</u>	<u>From CPC Symbol (existing)</u>	<u>To CPC Symbol(s)</u>
C	D06F 37/42	D06F 37/42, D06F 34/10, D06F 34/20, D06F 2103/40, D06F 2103/44, D06F 2105/44, D06F 2105/50, D06F 2105/62
C	D06F 39/00	D06F 39/00, D06F 31/00, D06F 31/005, D06F 33/00, D06F 33/04, D06F 33/06, D06F 33/08, D06F 33/10, D06F 33/30, D06F 33/32, D06F 33/34, D06F 33/36, D06F 33/37, D06F 33/38, D06F 33/40, D06F 33/42, D06F 33/43, D06F 33/44, D06F 33/46, D06F 33/47, D06F 33/48, D06F 33/50, D06F 33/52, D06F 33/54, D06F 33/56, D06F 33/57, D06F 33/58, D06F 33/60, D06F 33/62, D06F 33/63, D06F 33/64, D06F 33/65, D06F 33/68, D06F 33/69, D06F 33/70, D06F 33/72, D06F 33/74, D06F 33/76, D06F 34/00, D06F 34/04, D06F 34/05, D06F 34/06, D06F 34/08, D06F 34/10, D06F 34/14, D06F 34/16, D06F 34/18, D06F 34/20, D06F 34/22, D06F 34/24, D06F 34/26, D06F 34/28, D06F 34/30, D06F 34/32, D06F 34/34, D06F 37/42, D06F 58/32, D06F 58/34, D06F 58/36, D06F 58/38, D06F 58/40, D06F 58/42, D06F 58/44, D06F 58/45, D06F 58/46, D06F 58/48, D06F 58/50, D06F 58/52, D06F 2101/00, D06F 2101/02, D06F 2101/04, D06F 2101/06, D06F 2101/10, D06F 2101/12, D06F 2101/14, D06F 2101/16, D06F 2101/18, D06F 2101/20, D06F 2103/00, D06F 2103/02, D06F 2103/04, D06F 2103/06, D06F 2103/08, D06F 2103/10, D06F 2103/12, D06F 2103/14, D06F 2103/16, D06F 2103/18, D06F 2103/20, D06F 2103/22, D06F 2103/24, D06F 2103/26, D06F 2103/28, D06F 2103/30, D06F 2103/32, D06F 2103/34, D06F 2103/36, D06F 2103/38, D06F 2103/40, D06F 2103/42, D06F 2103/44, D06F 2103/46, D06F 2103/48, D06F 2103/50, D06F 2103/52, D06F 2103/54, D06F 2103/56, D06F 2103/58, D06F 2103/60, D06F 2103/62, D06F 2103/64, D06F 2103/66, D06F 2103/68, D06F 2103/70, D06F 2105/00, D06F 2105/02, D06F 2105/04, D06F 2105/06, D06F 2105/08, D06F 2105/10, D06F 2105/12, D06F 2105/14, D06F 2105/16, D06F 2105/18, D06F 2105/20, D06F 2105/22, D06F 2105/24, D06F 2105/26, D06F 2105/28, D06F 2105/30, D06F 2105/32, D06F 2105/34, D06F 2105/36, D06F 2105/38, D06F 2105/40, D06F 2105/42, D06F 2105/44, D06F 2105/46, D06F 2105/48, D06F 2105/50, D06F 2105/52, D06F 2105/54, D06F 2105/56, D06F 2105/58, D06F 2105/60, D06F 2105/62
D	D06F 39/002	<Administrative transfer to D06F 34/18 and D06F 34/22 simultaneously>
D	D06F 39/003	<Administrative transfer to D06F 34/18>
D	D06F 39/004	<Administrative transfer to D06F 34/22>
D	D06F 39/005	<Administrative transfer to D06F 34/28>
C	D06F 39/006	D06F 39/006, D06F 33/46, D06F 33/72, D06F 34/08, D06F 34/24, D06F 2103/44, D06F 2103/46, D06F 2103/50, D06F 2105/26
C	D06F 39/007	D06F 39/007, D06F 2103/20
C	D06F 39/008	D06F 39/008, D06F 33/65, D06F 2103/62, D06F 2105/40
C	D06F 39/02	D06F 39/02, D06F 33/37, D06F 33/57, D06F 2103/22
C	D06F 39/022	D06F 39/022, D06F 33/37, D06F 33/57, D06F 34/08, D06F 2103/22, D06F 2105/58, D06F 2105/60
C	D06F 39/024	D06F 39/024, D06F 33/37, D06F 33/57, D06F 2103/22
C	D06F 39/026	D06F 39/026, D06F 33/37, D06F 33/57, D06F 2103/22
C	D06F 39/028	D06F 39/028, D06F 33/37, D06F 33/57, D06F 2103/22

CPC NOTICE OF CHANGES XXX

DATE: FEBRUARY 1, 2020

PROJECT RP0608

Type*	<u>From CPC Symbol (existing)</u>	<u>To CPC Symbol(s)</u>
C	D06F 39/04	D06F 39/04, D06F 34/08, D06F 34/24, D06F 2103/52, D06F 2103/64, D06F 2105/10, D06F 2105/28
F	D06F 39/045	D06F 34/24, D06F 39/04, D06F 2103/16, D06F 2105/10
C	D06F 39/06	D06F 39/06, D06F 34/08, D06F 2105/50, D06F 2105/58, D06F 2105/60, D06F 2105/62
C	D06F 39/08	D06F 39/08, D06F 33/42, D06F 33/47, D06F 33/62, D06F 33/74, D06F 37/42
C	D06F 39/081	D06F 39/081, D06F 33/47, D06F 33/74, D06F 34/10, D06F 37/42, D06F 2105/58, D06F 2105/60
C	D06F 39/082	D06F 39/082, D06F 33/47, D06F 33/74, D06F 37/42, D06F 2103/42, D06F 2103/48, D06F 2105/58, D06F 2105/60
C	D06F 39/083	D06F 39/083, D06F 33/42, D06F 33/47, D06F 33/62, D06F 33/74, D06F 37/42
C	D06F 39/085	D06F 39/085, D06F 33/42, D06F 33/47, D06F 33/62, D06F 33/74, D06F 37/42, D06F 2103/42, D06F 2103/48
C	D06F 39/086	D06F 39/086, D06F 33/47, D06F 33/74, D06F 37/42
C	D06F 39/087	D06F 39/087, D06F 33/47, D06F 33/74, D06F 37/42, D06F 2103/18
C	D06F 39/088	D06F 39/088, D06F 33/47, D06F 33/74, D06F 37/42
C	D06F 39/10	D06F 39/10, D06F 2103/42
C	D06F 39/12	D06F 39/12, D06F 34/10, D06F 34/20
C	D06F 39/125	D06F 39/125, D06F 34/20
C	D06F 39/14	D06F 39/14, D06F 33/47, D06F 33/74, D06F 34/10, D06F 34/20, D06F 37/42, D06F 2103/40, D06F 2105/44
C	D06F 58/00	D06F 58/00, D06F 33/50, D06F 33/52, D06F 33/54, D06F 33/56, D06F 33/57, D06F 33/58, D06F 33/60, D06F 33/62, D06F 33/63, D06F 33/64, D06F 33/65, D06F 33/68, D06F 33/69, D06F 33/70, D06F 33/72, D06F 33/74, D06F 33/76, D06F 34/00, D06F 34/04, D06F 34/05, D06F 34/06, D06F 34/08, D06F 34/10, D06F 34/14, D06F 34/16, D06F 34/18, D06F 34/20, D06F 34/22, D06F 34/24, D06F 34/26, D06F 34/28, D06F 34/30, D06F 34/32, D06F 34/34, D06F 37/42, D06F 58/30, D06F 58/32, D06F 58/34, D06F 58/36, D06F 58/38, D06F 58/40, D06F 58/42, D06F 58/44, D06F 58/45, D06F 58/46, D06F 58/48, D06F 58/50, D06F 58/52, D06F 2101/00, D06F 2101/02, D06F 2101/04, D06F 2101/06, D06F 2101/10, D06F 2101/12, D06F 2101/14, D06F 2101/16, D06F 2101/18, D06F 2101/20, D06F 2103/00, D06F 2103/02, D06F 2103/04, D06F 2103/06, D06F 2103/08, D06F 2103/10, D06F 2103/12, D06F 2103/14, D06F 2103/16, D06F 2103/18, D06F 2103/20, D06F 2103/22, D06F 2103/24, D06F 2103/26, D06F 2103/28, D06F 2103/30, D06F 2103/32, D06F 2103/34, D06F 2103/36, D06F 2103/38, D06F 2103/40, D06F 2103/42, D06F 2103/44, D06F 2103/46, D06F 2103/48, D06F 2103/50, D06F 2103/52, D06F 2103/54, D06F 2103/56, D06F 2103/58, D06F 2103/60, D06F 2103/62, D06F 2103/64, D06F 2103/66, D06F 2103/68, D06F 2103/70, D06F 2105/00, D06F 2105/02, D06F 2105/04, D06F 2105/06, D06F 2105/08, D06F 2105/10, D06F 2105/12, D06F 2105/14, D06F 2105/16, D06F 2105/18, D06F 2105/20, D06F 2105/22, D06F 2105/24, D06F 2105/26, D06F 2105/28, D06F 2105/30, D06F 2105/32, D06F 2105/34, D06F 2105/36, D06F 2105/38, D06F 2105/40, D06F 2105/42, D06F 2105/44,

CPC NOTICE OF CHANGES XXX

DATE: FEBRUARY 1, 2020

PROJECT RP0608

<u>Type*</u>	<u>From CPC Symbol (existing)</u>	<u>To CPC Symbol(s)</u>
		D06F 2105/46, D06F 2105/48, D06F 2105/50, D06F 2105/52, D06F 2105/54, D06F 2105/56, D06F 2105/58, D06F 2105/60, D06F 2105/62
C	D06F 58/02	D06F 58/02, D06F 33/50, D06F 33/52, D06F 33/54, D06F 33/56, D06F 33/57, D06F 33/58, D06F 33/60, D06F 33/62, D06F 33/63, D06F 33/64, D06F 33/65, D06F 33/68, D06F 33/69, D06F 33/70, D06F 33/72, D06F 33/74, D06F 34/00, D06F 34/04, D06F 34/05, D06F 34/06, D06F 34/08, D06F 34/10, D06F 34/14, D06F 34/16, D06F 34/18, D06F 34/20, D06F 34/22, D06F 34/24, D06F 34/26, D06F 34/28, D06F 34/30, D06F 34/32, D06F 34/34, D06F37/42, D06F 58/30, D06F 58/32, D06F 58/34, D06F 58/36, D06F 58/38, D06F 58/40, D06F 58/42, D06F 58/44, D06F 58/45, D06F 58/46, D06F 58/48, D06F 58/50, D06F 58/52, D06F 2101/00, D06F 2101/02, D06F 2101/04, D06F 2101/06, D06F 2101/10, D06F 2101/12, D06F 2101/14, D06F 2101/16, D06F 2101/18, D06F 2101/20, D06F 2103/00, D06F 2103/02, D06F 2103/04, D06F 2103/06, D06F 2103/08, D06F 2103/10, D06F 2103/12, D06F 2103/14, D06F 2103/16, D06F 2103/18, D06F 2103/20, D06F 2103/22, D06F 2103/24, D06F 2103/26, D06F 2103/28, D06F 2103/30, D06F 2103/32, D06F 2103/34, D06F 2103/36, D06F 2103/38, D06F 2103/40, D06F 2103/42, D06F 2103/44, D06F 2103/46, D06F 2103/48, D06F 2103/50, D06F 2103/52, D06F 2103/54, D06F 2103/56, D06F 2103/58, D06F 2103/60, D06F 2103/62, D06F 2103/64, D06F 2103/66, D06F 2103/68, D06F 2103/70, D06F 2105/00, D06F 2105/02, D06F 2105/04, D06F 2105/06, D06F 2105/08, D06F 2105/10, D06F 2105/12, D06F 2105/14, D06F 2105/16, D06F 2105/18, D06F 2105/20, D06F 2105/22, D06F 2105/24, D06F 2105/26, D06F 2105/28, D06F 2105/30, D06F 2105/32, D06F 2105/34, D06F 2105/36, D06F 2105/38, D06F 2105/40, D06F 2105/42, D06F 2105/46, D06F 2105/48, D06F 2105/50, D06F 2105/52, D06F 2105/54, D06F 2105/56, D06F 2105/58, D06F 2105/60, D06F 2105/62
C	D06F 58/04	D06F 58/04, D06F 34/00, D06F 34/04, D06F 34/05, D06F 34/06, D06F 34/08, D06F 34/10, D06F 34/14, D06F 34/16, D06F 34/18, D06F 34/20, D06F 34/22, D06F 34/24, D06F 34/26, D06F 34/28, D06F 34/30, D06F 34/32, D06F 34/34, D06F 2101/00, D06F 2101/02, D06F 2101/04, D06F 2101/06, D06F 2101/10, D06F 2101/12, D06F 2101/14, D06F 2101/16, D06F 2101/18, D06F 2101/20, D06F 2103/02, D06F 2103/04, D06F 2103/06, D06F 2103/08, D06F 2103/20, D06F 2103/22, D06F 2103/40, D06F 2103/68, D06F 2103/70, D06F 2105/44, D06F 2105/50, D06F 2105/52, D06F 2105/54, D06F 2105/56, D06F 2105/58, D06F 2105/60, D06F 2105/62
C	D06F 58/08	D06F 58/08, D06F 34/10, D06F 2103/44, D06F 2103/46, D06F 2105/46, D06F 2105/48
C	D06F 58/10	D06F 58/10, D06F 34/26
C	D06F 58/12	D06F 58/12, D06F 34/26
C	D06F 58/14	D06F 58/14, D06F 34/26

CPC NOTICE OF CHANGES XXX

DATE: FEBRUARY 1, 2020

PROJECT RP0608

Type*	From CPC Symbol (existing)	To CPC Symbol(s)
C	D06F 58/20	D06F 58/20, D06F 33/63, D06F 33/64, D06F 34/04, D06F 34/05, D06F 34/10, D06F 34/16, D06F 34/18, D06F 34/20, D06F 34/26, D06F 34/28, D06F 34/30, D06F 34/32, D06F 34/34, D06F 58/45, D06F 58/52, D06F 2101/00, D06F 2101/02, D06F 2101/04, D06F 2101/06, D06F 2101/10, D06F 2101/12, D06F 2101/14, D06F 2101/16, D06F 2101/18, D06F 2101/20, D06F 2103/02, D06F 2103/04, D06F 2103/06, D06F 2103/08, D06F 2103/40, D06F 2103/54, D06F 2103/56, D06F 2103/68, D06F 2103/70, D06F 2105/30, D06F 2105/32, D06F 2105/36, D06F 2105/44, D06F 2105/50, D06F 2105/52, D06F 2105/54, D06F 2105/56, D06F 2105/58, D06F 2105/60, D06F 2105/62
C	D06F 58/203	D06F 58/203, D06F 33/50, D06F 33/52, D06F 33/54, D06F 33/56, D06F 33/57, D06F 33/58, D06F 33/60, D06F 33/62, D06F 33/63, D06F 33/64, D06F 33/65, D06F 33/68, D06F 33/69, D06F 33/70, D06F 33/72, D06F 33/74, D06F 33/76, D06F 34/00, D06F 34/04, D06F 34/05, D06F 34/06, D06F 34/08, D06F 34/10, D06F 34/14, D06F 34/16, D06F 34/18, D06F 34/20, D06F 34/22, D06F 34/24, D06F 34/26, D06F 34/28, D06F 34/30, D06F 34/32, D06F 34/34, D06F 37/42, D06F 58/30, D06F 58/32, D06F 58/34, D06F 58/36, D06F 58/38, D06F 58/40, D06F 58/42, D06F 58/44, D06F 58/45, D06F 58/46, D06F 58/48, D06F 58/50, D06F 58/52, D06F 2101/00, D06F 2101/02, D06F 2101/04, D06F 2101/06, D06F 2101/10, D06F 2101/12, D06F 2101/14, D06F 2101/16, D06F 2101/18, D06F 2101/20, D06F 2103/00, D06F 2103/02, D06F 2103/04, D06F 2103/06, D06F 2103/08, D06F 2103/10, D06F 2103/12, D06F 2103/14, D06F 2103/16, D06F 2103/18, D06F 2103/20, D06F 2103/22, D06F 2103/24, D06F 2103/26, D06F 2103/28, D06F 2103/30, D06F 2103/32, D06F 2103/34, D06F 2103/36, D06F 2103/38, D06F 2103/40, D06F 2103/42, D06F 2103/44, D06F 2103/46, D06F 2103/48, D06F 2103/50, D06F 2103/52, D06F 2103/54, D06F 2103/56, D06F 2103/58, D06F 2103/60, D06F 2103/62, D06F 2103/64, D06F 2103/66, D06F 2103/68, D06F 2103/70, D06F 2105/00, D06F 2105/02, D06F 2105/04, D06F 2105/06, D06F 2105/08, D06F 2105/10, D06F 2105/12, D06F 2105/14, D06F 2105/16, D06F 2105/18, D06F 2105/20, D06F 2105/22, D06F 2105/24, D06F 2105/26, D06F 2105/28, D06F 2105/30, D06F 2105/32, D06F 2105/34, D06F 2105/36, D06F 2105/38, D06F 2105/40, D06F 2105/42, D06F 2105/44, D06F 2105/46, D06F 2105/48, D06F 2105/50, D06F 2105/52, D06F 2105/54, D06F 2105/56, D06F 2105/58, D06F 2105/60, D06F 2105/62
C	D06F 58/206	D06F 58/206, D06F 58/48, D06F 2103/50, D06F 2105/26
C	D06F 58/22	D06F 58/22, D06F 58/45, D06F 2105/34
C	D06F 58/24	D06F 58/24, D06F 58/45, D06F 2103/58, D06F 2105/36
C	D06F 58/26	D06F 58/26, D06F 2103/52, D06F 2105/28
C	D06F 58/263	D06F 58/263, D06F 2103/52, D06F 2105/28
C	D06F 58/266	D06F 58/266, D06F 2103/52, D06F 2103/64, D06F 2105/28
D	D06F 58/28	<Administrative transfer to D06F 58/30>
D	D06F 2058/2803	<Administrative transfer to D06F 2101/00>
D	D06F 2058/2806	<Administrative transfer to D06F 58/38 and D06F 2101/00 simultaneously>

CPC NOTICE OF CHANGES XXX

DATE: FEBRUARY 1, 2020

PROJECT RP0608

Type*	From CPC Symbol (existing)	To CPC Symbol(s)
D	D06F 2058/2809	<Administrative transfer to D06F 58/38 and D06F 2101/02 simultaneously>
D	D06F 2058/2812	<Administrative transfer to D06F 58/38 and D06F 2101/14 simultaneously>
D	D06F 2058/2816	<Administrative transfer to D06F 58/38>
D	D06F 2058/2819	<Administrative transfer to D06F 58/38 and D06F 2103/08 simultaneously>
D	D06F 2058/2822	<Administrative transfer to D06F 58/38 and D06F 2103/10 simultaneously>
D	D06F 2058/2825	<Administrative transfer to D06F 58/38 and D06F 2103/10 simultaneously>
D	D06F 2058/2829	<Administrative transfer to D06F 58/38 and D06F 2103/08 simultaneously>
D	D06F 2058/2832	<Administrative transfer to D06F 58/38 and D06F 2103/08 simultaneously>
D	D06F 2058/2835	<Administrative transfer to D06F 58/38 and D06F 2103/10 simultaneously>
D	D06F 2058/2838	<Administrative transfer to D06F 58/38 and D06F 2103/10 simultaneously>
D	D06F 2058/2841	<Administrative transfer to D06F 58/38 and D06F 2103/12 simultaneously>
D	D06F 2058/2845	<Administrative transfer to D06F 58/38, D06F 2103/08 and D06F 2103/64 simultaneously>
D	D06F 2058/2848	<Administrative transfer to D06F 58/38 and D06F 2103/04 simultaneously>
D	D06F 2058/2851	<Administrative transfer to D06F 58/38 and D06F 2103/38 simultaneously>
D	D06F 2058/2854	<Administrative transfer to D06F 2103/00 >
D	D06F 2058/2858	<Administrative transfer to D06F 58/50 >
D	D06F 2058/2861	<Administrative transfer to D06F 2103/02>
D	D06F 2058/2864	<Administrative transfer to D06F 2103/36 and D06F 2105/24 simultaneously>
D	D06F 2058/2867	<Administrative transfer to D06F 2103/36 and D06F 2105/24 simultaneously>
D	D06F 2058/287	<Administrative transfer to D06F 2103/50 and D06F 2105/26 simultaneously>
D	D06F 2058/2874	<Administrative transfer to D06F 2103/50 and D06F 2105/26 simultaneously>
D	D06F 2058/2877	<Administrative transfer to D06F 2103/00, D06F 2103/34, D06F 2103/44 and D06F 2105/46 simultaneously>
D	D06F 2058/288	<Administrative transfer to D06F 2103/00, D06F 2103/34, D06F 2103/44 and D06F 2105/46 simultaneously>
D	D06F 2058/2883	<Administrative transfer to D06F 34/28 >
D	D06F 2058/2887	<Administrative transfer to D06F 34/28 and D06F 2105/58 simultaneously>
D	D06F 2058/289	<Administrative transfer to D06F 2105/28>
D	D06F 2058/2893	<Administrative transfer to D06F 2105/28>
D	D06F 2058/2896	<Administrative transfer to D06F 2103/38>

CPC NOTICE OF CHANGES XXX

DATE: FEBRUARY 1, 2020

PROJECT RP0608

<u>Type*</u>	<u>From CPC Symbol (existing)</u>	<u>To CPC Symbol(s)</u>
Q	D06F 58/30	D06F 58/30, D06F 33/50, D06F 33/52, D06F 33/54, D06F 33/56, D06F 33/57, D06F 33/58, D06F 33/60, D06F 33/62, D06F 33/63, D06F 33/64, D06F 33/65, D06F 33/68, D06F 33/69, D06F 33/70, D06F 33/72, D06F 33/74, D06F 33/76, D06F 34/00, D06F 34/04, D06F 34/05, D06F 34/06, D06F 34/08, D06F 34/10, D06F 34/14, D06F 34/16, D06F 34/18, D06F 34/20, D06F 34/22, D06F 34/24, D06F 34/26, D06F 34/28, D06F 34/30, D06F 34/32, D06F 34/34, D06F 37/42, D06F 58/32, D06F 58/34, D06F 58/36, D06F 58/38, D06F 58/40, D06F 58/42, D06F 58/44, D06F 58/45, D06F 58/46, D06F 58/48, D06F 58/50, D06F 58/52, D06F 2101/00, D06F 2101/02, D06F 2101/04, D06F 2101/06, D06F 2101/10, D06F 2101/12, D06F 2101/14, D06F 2101/16, D06F 2101/18, D06F 2101/20, D06F 2103/00, D06F 2103/02, D06F 2103/04, D06F 2103/06, D06F 2103/08, D06F 2103/10, D06F 2103/12, D06F 2103/14, D06F 2103/16, D06F 2103/18, D06F 2103/20, D06F 2103/22, D06F 2103/24, D06F 2103/26, D06F 2103/28, D06F 2103/30, D06F 2103/32, D06F 2103/34, D06F 2103/36, D06F 2103/38, D06F 2103/40, D06F 2103/42, D06F 2103/44, D06F 2103/46, D06F 2103/48, D06F 2103/50, D06F 2103/52, D06F 2103/54, D06F 2103/56, D06F 2103/58, D06F 2103/60, D06F 2103/62, D06F 2103/64, D06F 2103/66, D06F 2103/68, D06F 2103/70, D06F 2105/00, D06F 2105/02, D06F 2105/04, D06F 2105/06, D06F 2105/08, D06F 2105/10, D06F 2105/12, D06F 2105/14, D06F 2105/16, D06F 2105/18, D06F 2105/20, D06F 2105/22, D06F 2105/24, D06F 2105/26, D06F 2105/28, D06F 2105/30, D06F 2105/32, D06F 2105/34, D06F 2105/36, D06F 2105/38, D06F 2105/40, D06F 2105/42, D06F 2105/44, D06F 2105/46, D06F 2105/48, D06F 2105/50, D06F 2105/52, D06F 2105/54, D06F 2105/56, D06F 2105/58, D06F 2105/60, D06F 2105/62
Q	D06F 58/38	D06F 58/38, D06F 58/40, D06F 58/42, D06F 2103/00, D06F 2103/02, D06F 2103/04, D06F 2103/06, D06F 2103/08, D06F 2103/10, D06F 2103/12, D06F 2103/14, D06F 2103/16, D06F 2103/18, D06F 2103/20, D06F 2103/22, D06F 2103/24, D06F 2103/26, D06F 2103/28, D06F 2103/30, D06F 2103/32, D06F 2103/34, D06F 2103/36, D06F 2103/38, D06F 2103/40, D06F 2103/42, D06F 2103/44, D06F 2103/46, D06F 2103/48, D06F 2103/50, D06F 2103/52, D06F 2103/54, D06F 2103/56, D06F 2103/58, D06F 2103/60, D06F 2103/62, D06F 2103/64, D06F 2103/66, D06F 2103/68, D06F 2103/70, D06F 2105/00, D06F 2105/02, D06F 2105/04, D06F 2105/06, D06F 2105/08, D06F 2105/10, D06F 2105/12, D06F 2105/14, D06F 2105/16, D06F 2105/18, D06F 2105/20, D06F 2105/22, D06F 2105/24, D06F 2105/26, D06F 2105/28, D06F 2105/30, D06F 2105/32, D06F 2105/34, D06F 2105/36, D06F 2105/38, D06F 2105/40, D06F 2105/42, D06F 2105/44, D06F 2105/46, D06F 2105/48, D06F 2105/50, D06F 2105/52, D06F 2105/54, D06F 2105/56
Q	D06F 58/50	D06F 58/50, D06F 2105/00, D06F 2105/02, D06F 2105/04, D06F 2105/06, D06F 2105/08, D06F 2105/10, D06F 2105/12, D06F 2105/14, D06F 2105/16, D06F 2105/18, D06F 2105/20, D06F 2105/22, D06F 2105/24, D06F 2105/26, D06F 2105/28, D06F 2105/30, D06F 2105/32, D06F 2105/34, D06F 2105/36,

CPC NOTICE OF CHANGES XXX

DATE: FEBRUARY 1, 2020

PROJECT RP0608

Type*	<u>From CPC Symbol (existing)</u>	<u>To CPC Symbol(s)</u>
		D06F 2105/38, D06F 2105/40, D06F 2105/42, D06F 2105/44, D06F 2105/46, D06F 2105/48, D06F 2105/50, D06F 2105/52, D06F 2105/54, D06F 2105/56, D06F 2105/58, D06F 2105/60, D06F 2105/62
Q	D06F 2101/00	D06F 2101/00, D06F 2101/02, D06F 2101/04, D06F 2101/06, D06F 2101/10, D06F 2101/12, D06F 2101/14, D06F 2101/16, D06F 2101/18, D06F 2101/20
Q	D06F 2103/00	D06F 2103/00, D06F 2103/02, D06F 2103/04, D06F 2103/06, D06F 2103/08, D06F 2103/10, D06F 2103/12, D06F 2103/14, D06F 2103/16, D06F 2103/18, D06F 2103/20, D06F 2103/22, D06F 2103/24, D06F 2103/26, D06F 2103/28, D06F 2103/30, D06F 2103/32, D06F 2103/34, D06F 2103/36, D06F 2103/38, D06F 2103/40, D06F 2103/42, D06F 2103/44, D06F 2103/46, D06F 2103/48, D06F 2103/50, D06F 2103/52, D06F 2103/54, D06F 2103/56, D06F 2103/58, D06F 2103/60, D06F 2103/62, D06F 2103/64, D06F 2103/66, D06F 2103/68, D06F 2103/70
F	D06F 2202/00	D06F 33/30, D06F 33/50, D06F 33/52, D06F 33/54, D06F 33/56, D06F 33/57, D06F 33/58, D06F 33/60, D06F 33/62, D06F 33/63, D06F 33/64, D06F 33/65, D06F 33/68, D06F 33/69, D06F 33/70, D06F 33/72, D06F 33/74, D06F 33/76, D06F 34/00, D06F 34/04, D06F 34/05, D06F 34/06, D06F 34/08, D06F 34/10, D06F 34/14, D06F 34/16, D06F 34/18, D06F 34/20, D06F 34/22, D06F 34/24, D06F 34/26, D06F 34/28, D06F 34/30, D06F 34/32, D06F 34/34, D06F 37/42, D06F 2101/00, D06F 2101/02, D06F 2101/04, D06F 2101/06, D06F 2101/10, D06F 2101/12, D06F 2101/14, D06F 2101/16, D06F 2101/18, D06F 2101/20, D06F 2103/00, D06F 2103/02, D06F 2103/04, D06F 2103/06, D06F 2103/08, D06F 2103/10, D06F 2103/12, D06F 2103/14, D06F 2103/16, D06F 2103/18, D06F 2103/20, D06F 2103/22, D06F 2103/24, D06F 2103/26, D06F 2103/28, D06F 2103/30, D06F 2103/32, D06F 2103/34, D06F 2103/36, D06F 2103/38, D06F 2103/40, D06F 2103/42, D06F 2103/44, D06F 2103/46, D06F 2103/48, D06F 2103/50, D06F 2103/52, D06F 2103/54, D06F 2103/56, D06F 2103/58, D06F 2103/60, D06F 2103/62, D06F 2103/64, D06F 2103/66, D06F 2103/68, D06F 2103/70, D06F 2105/50, D06F 2105/52, D06F 2105/54, D06F 2105/56, D06F 2105/58, D06F 2105/60, D06F 2105/62
F	D06F 2202/02	D06F 33/30, D06F 33/50, D06F 33/52, D06F 33/54, D06F 33/56, D06F 33/57, D06F 33/58, D06F 33/60, D06F 33/62, D06F 33/63, D06F 33/64, D06F 33/65, D06F 33/68, D06F 33/69, D06F 33/70, D06F 33/72, D06F 33/74, D06F 33/76, D06F 37/42, D06F 2103/20, D06F 2103/22
F	D06F 2202/04	D06F 33/30, D06F 33/50, D06F 33/52, D06F 33/54, D06F 33/56, D06F 33/57, D06F 33/58, D06F 33/60, D06F 33/62, D06F 33/63, D06F 33/64, D06F 33/65, D06F 33/68, D06F 33/69, D06F 33/70, D06F 33/72, D06F 33/74, D06F 33/76, D06F 34/24, D06F 37/42, D06F 2103/16, D06F 2103/52

CPC NOTICE OF CHANGES XXX

DATE: FEBRUARY 1, 2020

PROJECT RP0608

Type*	<u>From CPC Symbol (existing)</u>	<u>To CPC Symbol(s)</u>
F	D06F 2202/06	D06F 33/30, D06F 33/50, D06F 33/52, D06F 33/54, D06F 33/56, D06F 33/57, D06F 33/58, D06F 33/60, D06F 33/62, D06F 33/63, D06F 33/64, D06F 33/65, D06F 33/68, D06F 33/69, D06F 33/70, D06F 33/72, D06F 33/74, D06F 33/76, D06F 37/42, D06F 2103/24, D06F 2103/46
F	D06F 2202/065	D06F 33/30, D06F 33/50, D06F 33/52, D06F 33/54, D06F 33/56, D06F 33/57, D06F 33/58, D06F 33/60, D06F 33/62, D06F 33/63, D06F 33/64, D06F 33/65, D06F 33/68, D06F 33/69, D06F 33/70, D06F 33/72, D06F 33/74, D06F 33/76, D06F 37/42, D06F 2103/24, D06F 2103/46
F	D06F 2202/08	D06F 33/30, D06F 33/50, D06F 33/52, D06F 33/54, D06F 33/56, D06F 33/57, D06F 33/58, D06F 33/60, D06F 33/62, D06F 33/63, D06F 33/64, D06F 33/65, D06F 33/68, D06F 33/69, D06F 33/70, D06F 33/72, D06F 33/74, D06F 33/76, D06F 37/42, D06F 2103/14, D06F 2103/42, D06F 2103/48
F	D06F 2202/085	D06F 33/30, D06F 33/50, D06F 33/52, D06F 33/54, D06F 33/56, D06F 33/57, D06F 33/58, D06F 33/60, D06F 33/62, D06F 33/63, D06F 33/64, D06F 33/65, D06F 33/68, D06F 33/69, D06F 33/70, D06F 33/72, D06F 33/74, D06F 33/76, D06F 37/42, D06F 2103/18
F	D06F 2202/10	D06F 33/30, D06F 33/32, D06F 33/34, D06F 33/36, D06F 33/37, D06F 33/38, D06F 33/40, D06F 33/42, D06F 33/43, D06F 33/44, D06F 33/46, D06F 33/47, D06F 33/48, D06F 33/50, D06F 33/52, D06F 33/54, D06F 33/56, D06F 33/57, D06F 33/58, D06F 33/60, D06F 33/62, D06F 33/63, D06F 33/64, D06F 33/65, D06F 33/68, D06F 33/69, D06F 33/70, D06F 33/72, D06F 33/74, D06F 33/76, D06F 37/42, D06F 2103/02, D06F 2103/04, D06F 2103/06, D06F 2103/08, D06F 2103/66
F	D06F 2202/12	D06F 33/30, D06F 33/36, D06F 33/50, D06F 33/52, D06F 33/54, D06F 33/56, D06F 33/57, D06F 33/58, D06F 33/60, D06F 33/62, D06F 33/63, D06F 33/64, D06F 33/65, D06F 33/68, D06F 33/69, D06F 33/70, D06F 33/72, D06F 33/74, D06F 33/76, D06F 34/00, D06F 34/04, D06F 34/05, D06F 34/06, D06F 34/08, D06F 34/10, D06F 34/14, D06F 34/16, D06F 34/18, D06F 34/20, D06F 34/22, D06F 34/24, D06F 34/26, D06F 34/28, D06F 34/30, D06F 34/32, D06F 34/34, D06F 37/42, D06F 2101/00, D06F 2101/02, D06F 2101/04, D06F 2101/06, D06F 2101/10, D06F 2101/12, D06F 2101/14, D06F 2101/16, D06F 2101/18, D06F 2101/20, D06F 2103/00, D06F 2103/02, D06F 2103/04, D06F 2103/06, D06F 2103/08, D06F 2103/10, D06F 2103/12, D06F 2103/14, D06F 2103/16, D06F 2103/18, D06F 2103/20, D06F 2103/22, D06F 2103/24, D06F 2103/26, D06F 2103/28, D06F 2103/30, D06F 2103/32, D06F 2103/34, D06F 2103/36, D06F 2103/38, D06F 2103/40, D06F 2103/42, D06F 2103/44, D06F 2103/46, D06F 2103/48, D06F 2103/50, D06F 2103/52, D06F 2103/54, D06F 2103/56, D06F 2103/58, D06F 2103/60, D06F 2103/62, D06F 2103/64, D06F 2103/66, D06F 2103/68, D06F 2103/70, D06F 2105/28, D06F 2105/40, D06F 2105/50, D06F 2105/52, D06F 2105/54, D06F 2105/56, D06F 2105/58, D06F 2105/60, D06F 2105/62

CPC NOTICE OF CHANGES XXX

DATE: FEBRUARY 1, 2020

PROJECT RP0608

Type*	From CPC Symbol (existing)	To CPC Symbol(s)
F	D06F 2204/00	D06F 33/30, D06F 33/36, D06F 33/38, D06F 33/43, D06F 33/44, D06F 33/46, D06F 33/47, D06F 33/48, D06F 33/50, D06F 33/52, D06F 33/54, D06F 33/56, D06F 33/57, D06F 33/58, D06F 33/60, D06F 33/62, D06F 33/63, D06F 33/64, D06F 33/65, D06F 33/68, D06F 33/69, D06F 33/70, D06F 33/72, D06F 33/74, D06F 33/76, D06F 34/00, D06F 34/04, D06F 34/05, D06F 34/06, D06F 34/08, D06F 34/10, D06F 34/14, D06F 34/16, D06F 34/18, D06F 34/20, D06F 34/22, D06F 34/24, D06F 34/26, D06F 34/28, D06F 34/30, D06F 34/32, D06F 34/34, D06F 37/42, D06F 2101/00, D06F 2101/02, D06F 2101/04, D06F 2101/06, D06F 2101/10, D06F 2101/12, D06F 2101/14, D06F 2101/16, D06F 2101/18, D06F 2101/20, D06F 2103/02, D06F 2103/04, D06F 2103/06, D06F 2103/08, D06F 2103/20, D06F 2103/22, D06F 2103/68, D06F 2103/70, D06F 2105/00, D06F 2105/50, D06F 2105/52, D06F 2105/54, D06F 2105/56, D06F 2105/58, D06F 2105/60, D06F 2105/62
F	D06F 2204/02	D06F 33/30, D06F 33/36, D06F 33/37, D06F 33/38, D06F 33/43, D06F 33/44, D06F 33/46, D06F 33/47, D06F 33/48, D06F 33/50, D06F 33/52, D06F 33/54, D06F 33/56, D06F 33/57, D06F 33/58, D06F 33/60, D06F 33/62, D06F 33/63, D06F 33/64, D06F 33/65, D06F 33/68, D06F 33/69, D06F 33/70, D06F 33/72, D06F 33/74, D06F 33/76, D06F 37/42, D06F 2105/42
F	D06F 2204/04	D06F 33/30, D06F 33/36, D06F 33/38, D06F 33/43, D06F 33/44, D06F 33/46, D06F 33/47, D06F 33/48, D06F 33/50, D06F 33/52, D06F 33/54, D06F 33/56, D06F 33/57, D06F 33/58, D06F 33/60, D06F 33/62, D06F 33/63, D06F 33/64, D06F 33/65, D06F 33/68, D06F 33/69, D06F 33/70, D06F 33/72, D06F 33/74, D06F 33/76, D06F 34/24, D06F 37/42, D06F 2105/10, D06F 2105/28
F	D06F 2204/06	D06F 33/30, D06F 33/36, D06F 33/38, D06F 33/40, D06F 33/43, D06F 33/44, D06F 33/46, D06F 33/47, D06F 33/48, D06F 33/50, D06F 33/52, D06F 33/54, D06F 33/56, D06F 33/57, D06F 33/58, D06F 33/60, D06F 33/62, D06F 33/63, D06F 33/64, D06F 33/65, D06F 33/68, D06F 33/69, D06F 33/70, D06F 33/72, D06F 33/74, D06F 33/76, D06F 37/42, D06F 2105/46
F	D06F 2204/065	D06F 33/30, D06F 33/36, D06F 33/38, D06F 33/40, D06F 33/43, D06F 33/44, D06F 33/46, D06F 33/47, D06F 33/48, D06F 33/50, D06F 33/52, D06F 33/54, D06F 33/56, D06F 33/57, D06F 33/58, D06F 33/60, D06F 33/62, D06F 33/63, D06F 33/64, D06F 33/65, D06F 33/68, D06F 33/69, D06F 33/70, D06F 33/72, D06F 33/74, D06F 33/76, D06F 37/42, D06F 2105/48
F	D06F 2204/08	D06F 33/30, D06F 33/36, D06F 33/38, D06F 33/43, D06F 33/44, D06F 33/46, D06F 33/47, D06F 33/48, D06F 33/50, D06F 33/52, D06F 33/54, D06F 33/56, D06F 33/57, D06F 33/58, D06F 33/60, D06F 33/62, D06F 33/63, D06F 33/64, D06F 33/65, D06F 33/68, D06F 33/69, D06F 33/70, D06F 33/72, D06F 33/74, D06F 33/76, D06F 37/42, D06F 2105/02, D06F 2105/06, D06F 2105/08
F	D06F 2204/082	D06F 33/30, D06F 33/36, D06F 33/38, D06F 33/43, D06F 33/44, D06F 33/46, D06F 33/47, D06F 33/48, D06F 33/50, D06F 33/52, D06F 33/54, D06F 33/56, D06F 33/57, D06F 33/58, D06F 33/60, D06F 33/62, D06F 33/63, D06F 33/64, D06F 33/65, D06F 33/68, D06F 33/69, D06F 33/70, D06F 33/72, D06F 33/74, D06F 33/76, D06F 37/42, D06F 2105/06

CPC NOTICE OF CHANGES XXX

DATE: FEBRUARY 1, 2020

PROJECT RP0608

Type*	<u>From CPC Symbol (existing)</u>	<u>To CPC Symbol(s)</u>
F	D06F 2204/084	D06F 33/30, D06F 33/36, D06F 33/38, D06F 33/42, D06F 33/43, D06F 33/44, D06F 33/46, D06F 33/47, D06F 33/48, D06F 33/50, D06F 33/52, D06F 33/54, D06F 33/56, D06F 33/57, D06F 33/58, D06F 33/60, D06F 33/62, D06F 33/63, D06F 33/64, D06F 33/65, D06F 33/68, D06F 33/69, D06F 33/70, D06F 33/72, D06F 33/74, D06F 33/76, D06F 37/42, D06F 2105/08
F	D06F 2204/086	D06F 33/30, D06F 33/34, D06F 33/36, D06F 33/38, D06F 33/43, D06F 33/44, D06F 33/46, D06F 33/47, D06F 33/48, D06F 33/50, D06F 33/52, D06F 33/54, D06F 33/56, D06F 33/57, D06F 33/58, D06F 33/60, D06F 33/62, D06F 33/63, D06F 33/64, D06F 33/65, D06F 33/68, D06F 33/69, D06F 33/70, D06F 33/72, D06F 33/74, D06F 33/76, D06F 37/42, D06F 2105/02
F	D06F 2204/088	D06F 33/30, D06F 33/34, D06F 33/36, D06F 33/38, D06F 33/43, D06F 33/44, D06F 33/46, D06F 33/47, D06F 33/48, D06F 33/50, D06F 33/52, D06F 33/54, D06F 33/56, D06F 33/57, D06F 33/58, D06F 33/60, D06F 33/62, D06F 33/63, D06F 33/64, D06F 33/65, D06F 33/68, D06F 33/69, D06F 33/70, D06F 33/72, D06F 33/74, D06F 33/76, D06F 37/42, D06F 2105/04
F	D06F 2204/10	D06F 33/30, D06F 33/36, D06F 33/38, D06F 33/43, D06F 33/44, D06F 33/46, D06F 33/47, D06F 33/48, D06F 33/50, D06F 33/52, D06F 33/54, D06F 33/56, D06F 33/57, D06F 33/58, D06F 33/60, D06F 33/62, D06F 33/63, D06F 33/64, D06F 33/65, D06F 33/68, D06F 33/69, D06F 33/70, D06F 33/72, D06F 33/74, D06F 33/76, D06F 34/04, D06F 34/05, D06F 37/42, D06F 2103/66, D06F 2105/00, D06F 2105/12, D06F 2105/50, D06F 2105/60, D06F 2105/62
F	D06F 2210/00	D06F 33/30, D06F 33/50, D06F 33/52, D06F 33/54, D06F 33/56, D06F 33/57, D06F 33/58, D06F 33/60, D06F 33/62, D06F 33/63, D06F 33/64, D06F 33/65, D06F 33/68, D06F 33/69, D06F 33/70, D06F 33/72, D06F 33/74, D06F 33/76, D06F 34/04, D06F 34/05, D06F 37/42, D06F 2105/58
F	D06F 2212/00	D06F 33/30, D06F 33/44, D06F 33/50, D06F 33/52, D06F 33/54, D06F 33/56, D06F 33/57, D06F 33/58, D06F 33/60, D06F 33/62, D06F 33/63, D06F 33/64, D06F 33/65, D06F 33/68, D06F 33/69, D06F 33/70, D06F 33/72, D06F 33/74, D06F 33/76, D06F 34/06, D06F 37/42, D06F 2103/38, D06F 2105/56
F	D06F 2212/02	D06F 33/30, D06F 33/44, D06F 33/50, D06F 33/52, D06F 33/54, D06F 33/56, D06F 33/57, D06F 33/58, D06F 33/60, D06F 33/62, D06F 33/63, D06F 33/64, D06F 33/65, D06F 33/68, D06F 33/69, D06F 33/70, D06F 33/72, D06F 33/74, D06F 33/76, D06F 34/06, D06F 37/42, D06F 2103/38, D06F 2105/56
F	D06F 2212/04	D06F 33/30, D06F 33/44, D06F 33/50, D06F 33/52, D06F 33/54, D06F 33/56, D06F 33/57, D06F 33/58, D06F 33/60, D06F 33/62, D06F 33/63, D06F 33/64, D06F 33/65, D06F 33/68, D06F 33/69, D06F 33/70, D06F 33/72, D06F 33/74, D06F 33/76, D06F 34/06, D06F 37/42, D06F 2103/38
F	D06F 2212/06	D06F 33/30, D06F 33/44, D06F 33/50, D06F 33/52, D06F 33/54, D06F 33/56, D06F 33/57, D06F 33/58, D06F 33/60, D06F 33/62, D06F 33/63, D06F 33/64, D06F 33/65, D06F 33/68, D06F 33/69, D06F 33/70, D06F 33/72, D06F 33/74, D06F 33/76, D06F 34/06, D06F 37/42, D06F 2103/38, D06F 2105/50, D06F 2105/62

CPC NOTICE OF CHANGES XXX

DATE: FEBRUARY 1, 2020

PROJECT RP0608

<u>Type*</u>	<u>From CPC Symbol (existing)</u>	<u>To CPC Symbol(s)</u>
F	D06F 2214/00	D06F 33/30, D06F 33/50, D06F 33/52, D06F 33/54, D06F 33/56, D06F 33/57, D06F 33/58, D06F 33/60, D06F 33/62, D06F 33/63, D06F 33/64, D06F 33/65, D06F 33/68, D06F 33/69, D06F 33/70, D06F 33/72, D06F 33/74, D06F 33/76, D06F 37/42, D06F 2101/00, D06F 2101/02, D06F 2101/04, D06F 2101/06, D06F 2101/10, D06F 2101/12, D06F 2101/14, D06F 2101/16, D06F 2101/18, D06F 2101/20, D06F 2105/54
F	D06F 2216/00	D06F 33/30, D06F 33/50, D06F 33/52, D06F 33/54, D06F 33/56, D06F 33/57, D06F 33/58, D06F 33/60, D06F 33/62, D06F 33/63, D06F 33/64, D06F 33/65, D06F 33/68, D06F 33/69, D06F 33/70, D06F 33/72, D06F 33/74, D06F 33/76, D06F 34/04, D06F 34/05, D06F 37/42, D06F 2105/54, D06F 2105/58
F	D06F 2220/00	D06F 33/30, D06F 33/44, D06F 33/48, D06F 33/50, D06F 33/52, D06F 33/54, D06F 33/56, D06F 33/57, D06F 33/58, D06F 33/60, D06F 33/62, D06F 33/63, D06F 33/64, D06F 33/65, D06F 33/68, D06F 33/69, D06F 33/70, D06F 33/72, D06F 33/74, D06F 33/76, D06F 34/06, D06F 37/42, D06F 2103/38, D06F 2105/56
F	D06F 2222/00	D06F 33/30, D06F 33/50, D06F 33/52, D06F 33/54, D06F 33/56, D06F 33/57, D06F 33/58, D06F 33/60, D06F 33/62, D06F 33/63, D06F 33/64, D06F 33/65, D06F 33/68, D06F 33/69, D06F 33/70, D06F 33/72, D06F 33/74, D06F 33/76, D06F 34/16, D06F 37/42, D06F 2103/26
F	D06F 2224/00	D06F 33/30, D06F 33/47, D06F 33/50, D06F 33/52, D06F 33/54, D06F 33/56, D06F 33/57, D06F 33/58, D06F 33/60, D06F 33/62, D06F 33/63, D06F 33/64, D06F 33/65, D06F 33/68, D06F 33/69, D06F 33/70, D06F 33/72, D06F 33/74, D06F 33/76, D06F 37/42, D06F 2103/40, D06F 2105/44, D06F 2105/58, D06F 2105/60
F	D06F 2226/00	D06F 33/30, D06F 33/46, D06F 33/50, D06F 33/52, D06F 33/54, D06F 33/56, D06F 33/57, D06F 33/58, D06F 33/60, D06F 33/62, D06F 33/63, D06F 33/64, D06F 33/65, D06F 33/68, D06F 33/69, D06F 33/70, D06F 33/72, D06F 33/74, D06F 33/76, D06F 34/24, D06F 37/42, D06F 2103/50, D06F 2105/26
D	D06F 2232/00	<Administrative transfer to D06F 35/005>
D	D06F 2232/02	<Administrative transfer to D06F 35/00>
D	D06F 2232/04	<Administrative transfer to D06F 35/006>
D	D06F 2232/06	<Administrative transfer to D06F 35/006>
D	D06F 2232/08	<Administrative transfer to D06F 35/007>
D	D06F 2232/10	<Administrative transfer to D06F 25/00>
D	D06F 2700/00	<Administrative transfer to D06F 21/00 ADD and D06F 37/30 INV simultaneously>
D	D06F 2700/04	<Administrative transfer to D06F 21/00 ADD and D06F 37/36 INV simultaneously>
D	D06F 2700/05	<Administrative transfer to D06F 21/00 ADD and D06F 37/40 INV simultaneously>
D	D06F 2700/052	<Administrative transfer to D06F 21/00 ADD and D06F 37/30 INV simultaneously>
D	D06F 2700/055	<Administrative transfer to D06F 21/00 ADD and D06F 37/30 INV simultaneously>
D	D06F 2700/057	<Administrative transfer to D06F 21/00 ADD and D06F 37/38 INV simultaneously>

CPC NOTICE OF CHANGES XXX

DATE: FEBRUARY 1, 2020

PROJECT RP0608

* C = entries with modified file scope where reclassification of documents from the entries is involved; Q = new entries which are firstly populated with documents via administrative transfers from deleted (D) entries. Afterwards, the transferred documents into the Q entry will either stay or be moved to more appropriate entries, as determined by intellectual reclassification; D = deleted entries; F = frozen entries will be deleted once reclassification of documents from the entries is completed.

NOTES:

- Only C, D, F, and Q type entries are included in the table above.
- When multiple symbols are included in the “To” column, do not use ranges of symbols.
- For administrative transfer of documents, the following text should be used: “< administrative transfer to XX>”, “<administrative transfer to XX and YY simultaneously>”, or “<administrative transfer to XX, YY ...and ZZ simultaneously>” when administrative transfer of the same documents is to more than one place.
- Administrative transfer to main trunk groups is assumed to be the source allocation type, unless otherwise indicated.
- Administrative transfer to 2000/Y series groups is assumed to be “additional information”.
- If needed, instructions for allocation type should be indicated within the angle brackets using the abbreviations “ADD” or “INV”: <administrative transfer to XX ADD>, <administrative transfer to XX INV>, or < administrative transfer to XX ADD, YY INV, ... and ZZ ADD simultaneously>.
- In certain situations, the “D” entries of 2000-series or Y-series groups may not require a destination (“To”) symbol, however it is required to specify “<no transfer>” in the “To” column for such cases.
- RCL is not needed for finalisation projects.

CPC NOTICE OF CHANGES XXX

DATE: FEBRUARY 1, 2020

PROJECT RP0608

4. CHANGES TO THE CPC-TO-IPC CONCORDANCE LIST (CICL)

CPC	IPC	Action*
D06F 33/02		DELETE
D06F 33/30	D06F 33/30	NEW
D06F 33/32	D06F 33/32	NEW
D06F 33/34	D06F 33/34	NEW
D06F 33/36	D06F 33/36	NEW
D06F 33/37	D06F 33/37	NEW
D06F 33/38	D06F 33/38	NEW
D06F 33/40	D06F 33/40	NEW
D06F 33/42	D06F 33/42	NEW
D06F 33/43	D06F 33/43	NEW
D06F 33/44	D06F 33/44	NEW
D06F 33/46	D06F 33/46	NEW
D06F 33/47	D06F 33/47	NEW
D06F 33/48	D06F 33/48	NEW
D06F 33/50	D06F 33/50	NEW
D06F 33/52	D06F 33/52	NEW
D06F 33/54	D06F 33/54	NEW
D06F 33/56	D06F 33/56	NEW
D06F 33/57	D06F 33/57	NEW
D06F 33/58	D06F 33/58	NEW
D06F 33/60	D06F 33/60	NEW
D06F 33/62	D06F 33/62	NEW
D06F 33/63	D06F 33/63	NEW
D06F 33/64	D06F 33/64	NEW
D06F 33/65	D06F 33/65	NEW
D06F 33/68	D06F 33/68	NEW
D06F 33/69	D06F 33/69	NEW
D06F 33/70	D06F 33/70	NEW
D06F 33/72	D06F 33/72	NEW
D06F 33/74	D06F 33/74	NEW
D06F 33/76	D06F 33/76	NEW
D06F 34/00	D06F 34/00	NEW
D06F 34/04	D06F 34/04	NEW
D06F 34/05	D06F 34/05	NEW
D06F 34/06	D06F 34/06	NEW
D06F 34/08	D06F 34/08	NEW
D06F 34/10	D06F 34/10	NEW
D06F 34/14	D06F 34/14	NEW
D06F 34/16	D06F 34/16	NEW
D06F 34/18	D06F 34/18	NEW

CPC NOTICE OF CHANGES XXX

DATE: FEBRUARY 1, 2020

PROJECT RP0608

<u>CPC</u>	<u>IPC</u>	<u>Action*</u>
D06F 34/20	D06F 34/20	NEW
D06F 34/22	D06F 34/22	NEW
D06F 34/24	D06F 34/24	NEW
D06F 34/26	D06F 34/26	NEW
D06F 34/28	D06F 34/28	NEW
D06F 34/30	D06F 34/30	NEW
D06F 34/32	D06F 34/32	NEW
D06F 34/34	D06F 34/34	NEW
D06F 39/002		DELETE
D06F 39/003		DELETE
D06F 39/004		DELETE
D06F 39/005		DELETE
D06F 58/28		DELETE
D06F 2058/2803		DELETE
D06F 2058/2806		DELETE
D06F 2058/2809		DELETE
D06F 2058/2812		DELETE
D06F 2058/2816		DELETE
D06F 2058/2819		DELETE
D06F 2058/2822		DELETE
D06F 2058/2825		DELETE
D06F 2058/2829		DELETE
D06F 2058/2832		DELETE
D06F 2058/2835		DELETE
D06F 2058/2838		DELETE
D06F 2058/2841		DELETE
D06F 2058/2845		DELETE
D06F 2058/2848		DELETE
D06F 2058/2851		DELETE
D06F 2058/2854		DELETE
D06F 2058/2858		DELETE
D06F 2058/2861		DELETE
D06F 2058/2864		DELETE
D06F 2058/2867		DELETE
D06F 2058/287		DELETE
D06F 2058/2874		DELETE
D06F 2058/2877		DELETE
D06F 2058/288		DELETE
D06F 2058/2883		DELETE
D06F 2058/2887		DELETE
D06F 2058/289		DELETE
D06F 2058/2893		DELETE
D06F 2058/2896		DELETE
D06F 58/30	D06F 58/30	NEW
D06F 58/32	D06F 58/32	NEW

CPC NOTICE OF CHANGES XXX

DATE: FEBRUARY 1, 2020

PROJECT RP0608

<u>CPC</u>	<u>IPC</u>	<u>Action*</u>
D06F 58/34	D06F 58/34	NEW
D06F 58/36	D06F 58/36	NEW
D06F 58/38	D06F 58/38	NEW
D06F 58/40	D06F 58/40	NEW
D06F 58/42	D06F 58/42	NEW
D06F 58/44	D06F 58/44	NEW
D06F 58/45	D06F 58/45	NEW
D06F 58/46	D06F 58/46	NEW
D06F 58/48	D06F 58/48	NEW
D06F 58/50	D06F 58/50	NEW
D06F 58/52	D06F 58/52	NEW
D06F 2101/00	D06F 101/00	NEW
D06F 2101/02	D06F 101/02	NEW
D06F 2101/04	D06F 101/04	NEW
D06F 2101/06	D06F 101/06	NEW
D06F 2101/10	D06F 101/10	NEW
D06F 2101/12	D06F 101/12	NEW
D06F 2101/14	D06F 101/14	NEW
D06F 2101/16	D06F 101/16	NEW
D06F 2101/18	D06F 101/18	NEW
D06F 2101/20	D06F 101/20	NEW
D06F 2103/00	D06F 103/00	NEW
D06F 2103/02	D06F 103/02	NEW
D06F 2103/04	D06F 103/04	NEW
D06F 2103/06	D06F 103/06	NEW
D06F 2103/08	D06F 103/08	NEW
D06F 2103/10	D06F 103/10	NEW
D06F 2103/12	D06F 103/12	NEW
D06F 2103/14	D06F 103/14	NEW
D06F 2103/16	D06F 103/16	NEW
D06F 2103/18	D06F 103/18	NEW
D06F 2103/20	D06F 103/20	NEW
D06F 2103/22	D06F 103/22	NEW
D06F 2103/24	D06F 103/24	NEW
D06F 2103/26	D06F 103/26	NEW
D06F 2103/28	D06F 103/28	NEW
D06F 2103/30	D06F 103/30	NEW
D06F 2103/32	D06F 103/32	NEW
D06F 2103/34	D06F 103/34	NEW
D06F 2103/36	D06F 103/36	NEW
D06F 2103/38	D06F 103/38	NEW
D06F 2103/40	D06F 103/40	NEW
D06F 2103/42	D06F 103/42	NEW
D06F 2103/44	D06F 103/44	NEW
D06F 2103/46	D06F 103/46	NEW

CPC NOTICE OF CHANGES XXX

DATE: FEBRUARY 1, 2020

PROJECT RP0608

<u>CPC</u>	<u>IPC</u>	<u>Action*</u>
D06F 2103/48	D06F 103/48	NEW
D06F 2103/50	D06F 103/50	NEW
D06F 2103/52	D06F 103/52	NEW
D06F 2103/54	D06F 103/54	NEW
D06F 2103/56	D06F 103/56	NEW
D06F 2103/58	D06F 103/58	NEW
D06F 2103/60	D06F 103/60	NEW
D06F 2103/62	D06F 103/62	NEW
D06F 2103/64	D06F 103/64	NEW
D06F 2103/66	D06F 103/66	NEW
D06F 2103/68	D06F 103/68	NEW
D06F 2103/70	D06F 103/70	NEW
D06F 2105/00	D06F 105/00	NEW
D06F 2105/02	D06F 105/02	NEW
D06F 2105/04	D06F 105/04	NEW
D06F 2105/06	D06F 105/06	NEW
D06F 2105/08	D06F 105/08	NEW
D06F 2105/10	D06F 105/10	NEW
D06F 2105/12	D06F 105/12	NEW
D06F 2105/14	D06F 105/14	NEW
D06F 2105/16	D06F 105/16	NEW
D06F 2105/18	D06F 105/18	NEW
D06F 2105/20	D06F 105/20	NEW
D06F 2105/22	D06F 105/22	NEW
D06F 2105/24	D06F 105/24	NEW
D06F 2105/26	D06F 105/26	NEW
D06F 2105/28	D06F 105/28	NEW
D06F 2105/30	D06F 105/30	NEW
D06F 2105/32	D06F 105/32	NEW
D06F 2105/34	D06F 105/34	NEW
D06F 2105/36	D06F 105/36	NEW
D06F 2105/38	D06F 105/38	NEW
D06F 2105/40	D06F 105/40	NEW
D06F 2105/42	D06F 105/42	NEW
D06F 2105/44	D06F 105/44	NEW
D06F 2105/46	D06F 105/46	NEW
D06F 2105/48	D06F 105/48	NEW
D06F 2105/50	D06F 105/50	NEW
D06F 2105/52	D06F 105/52	NEW
D06F 2105/54	D06F 105/54	NEW
D06F 2105/56	D06F 105/56	NEW
D06F 2105/58	D06F 105/58	NEW
D06F 2105/60	D06F 105/60	NEW
D06F 2105/62	D06F 105/62	NEW
D06F 2232/00		DELETE

CPC NOTICE OF CHANGES XXX

DATE: FEBRUARY 1, 2020

PROJECT RP0608

<u>CPC</u>	<u>IPC</u>	<u>Action*</u>
D06F 2232/02		DELETE
D06F 2232/04		DELETE
D06F 2232/06		DELETE
D06F 2232/08		DELETE
D06F 2232/10		DELETE
D06F 2700/00		DELETE
D06F 2700/04		DELETE
D06F 2700/05		DELETE
D06F 2700/052		DELETE
D06F 2700/055		DELETE
D06F 2700/057		DELETE

*Action column:

- For an (N) or (Q) entry, provide an IPC symbol and complete the Action column with “NEW.”
- For an existing CPC main trunk entry or indexing entry where the existing IPC symbol needs to be changed, provide an updated IPC symbol and complete the Action column with “UPDATED.”
- For a (D) CPC entry or indexing entry complete the Action column with “DELETE.” IPC symbol does not need to be included in the IPC column.
- For an (N) 2000 series CPC entry which is positioned within the main trunk scheme (breakdown code) provide an IPC symbol and complete the action column with “NEW”.
- For an (N) 2000 series CPC entry positioned at the end of the CPC scheme (orthogonal code), with no IPC equivalent, complete the IPC column with “CPCONLY” and complete the action column with “NEW”.

NOTES:

- F symbols are not included in the CICL table above.
- T and M symbols are not included in the CICL table above unless a change to the existing IPC is desired.

CPC NOTICE OF CHANGES XXX

DATE: FEBRUARY 1, 2020

PROJECT RP0608

5. CROSS-REFERENCE LIST (CRL)

Definitions references impacted by this revision project

<u>Location of reference to be changed</u>	<u>Referenced subclass or group to be changed</u>	<u>Section of definition</u>	<u>Action; New reference symbol; New text</u>
A47L 15/0055	D06F 39/004	Informative references	Replace symbol “D06F 39/004” with D06F 34/22.
A47L 15/4287	D06F 39/045	Informative references	Replace symbol “D06F 39/045” with D06F 39/04.
A47L 15/4293	D06F 39/005	Informative references	Replace symbol “D06F 39/005” with D06F 34/28.
A47L 15/4295	D06F 39/003	Informative references	Replace symbol “D06F 39/003” with D06F 34/18.
A47L 15/4297	D06F 39/004	Informative references	Replace symbol “D06F 39/004” with D06F 34/22.
A47L 15/46	D06F 33/02	Informative references	Replace symbol “D06F 33/02” with D06F 33/00.
G01G 19/00	D06F 39/003	Application-oriented references	Replace symbol “D06F 39/003” with D06F 34/18.

NOTES:

- The CRL tables above are used for changes to locations **outside** of the project scope. Changes to references in scheme titles or definitions **inside** the project scope will be reflected in the “scheme change” template or one of the “definition” templates.
- In addition to other changes proposed in the tables above, in the column titled “Referenced subclass or group to be changed,” **referenced** D symbols should indicate an action of “delete” or should indicate a replacement symbol and **referenced** F symbols should indicate a replacement symbol.
- When a reference is deleted, text related to that reference will also be deleted unless other references or a range of references associated with the same text remain.