

EUROPEAN PATENT OFFICE
U.S. PATENT AND TRADEMARK OFFICE

CPC NOTICE OF CHANGES 800

DATE: JANUARY 1, 2020

PROJECT RP0430

The following classification changes will be effected by this Notice of Changes:

<u>Action</u>	<u>Subclass</u>	<u>Group(s)</u>
SCHEME:		
Symbols New:	B64C	1/0683, 1/0685
	B64C	39/029
	B64F	1/027, 1/029, 1/0295, 1/0297, 1/0299, 1/322, 1/324, 1/326
Titles Changed:	B64C	39/028
	B64F	1/32
Warnings New:	B64C	1/0009, 2001/0045, 1/068, 1/0683, 1/0685
	B64C	3/10, 3/16
	B64C	7/00
	B64C	39/00, 39/029
	B64F	1/02, 1/027, 1/029, 1/0295, 1/0297, 1/0299, 1/32, 1/322, 1/324, 1/326
DEFINITIONS:		
Definitions New:	B64C	1/0683, 1/0685, 39/029
	B64F	1/027, 1/029, 1/0295, 1/0297, 1/0299, 1/322, 1/324, 1/326
Definitions Modified:	B64C	37/02
	B64F	1/02, 1/32, 1/362

No other subclasses/groups are impacted by this Notice of Changes.

CPC NOTICE OF CHANGES 800

DATE: JANUARY 1, 2020

PROJECT RP0430

This Notice of Changes includes the following *[Check the ones included]:*

1. CLASSIFICATION SCHEME CHANGES

- A. New, Modified or Deleted Group(s)
- B. New, Modified or Deleted Warning(s)
- C. New, Modified or Deleted Note(s)
- D. New, Modified or Deleted Guidance Heading(s)

2. DEFINITIONS

- A. New or Modified Definitions (Full definition template)
- B. Modified or Deleted Definitions (Definitions Quick Fix)

- 3. REVISION CONCORDANCE LIST (RCL)
- 4. CHANGES TO THE CPC-TO-IPC CONCORDANCE LIST (CICL)
- 5. CHANGES TO THE CROSS-REFERENCE LIST (CRL)

CPC NOTICE OF CHANGES 800

DATE: JANUARY 1, 2020

PROJECT RP0430

1. CLASSIFICATION SCHEME CHANGES

A. New, Modified or Deleted Group(s)

SUBCLASS B64C - AEROPLANES; HELICOPTERS

<u>Type*</u>	<u>Symbol</u>	<u>Indent Level Number of dots (e.g. 0, 1, 2)</u>	<u>Title</u> <u>“CPC only” text should normally be enclosed in {curly brackets}**</u>	<u>Transferred to#</u>
C	B64C 1/0009	1	{Aerodynamic aspects}	B64C 1/0009, B64C 39/029
C	B64C 2001/0045	1	{Fuselages characterised by special shapes}	B64C 2001/0045, B64C 39/029
C	B64C 1/068	2	{Fuselage sections}	B64C 1/068, B64C 1/0683, B64C 1/0685
N	B64C 1/0683	3	{Nose cones}	
N	B64C 1/0685	3	{Tail cones}	
C	B64C 3/10	1	Shape of wings	B64C 3/10, B64C 39/029
C	B64C 3/16	2	Frontal aspect	B64C 3/16, B64C 39/029
C	B64C 7/00	0	Structures or fairings not otherwise provided for	B64C 7/00, B64C 39/029
C	B64C 39/00	0	Aircraft not otherwise provided for	B64C 39/00, B64C 39/029
M	B64C 39/028	2	{Micro-sized aircraft}	
N	B64C 39/029	1	{Asymmetrical aircraft}	

CPC NOTICE OF CHANGES 800

DATE: JANUARY 1, 2020

PROJECT RP0430

SUBCLASS B64F - GROUND OR AIRCRAFT-CARRIER-DECK INSTALLATIONS SPECIALLY ADAPTED FOR USE IN CONNECTION WITH AIRCRAFT; DESIGNING, MANUFACTURING, ASSEMBLING, CLEANING, MAINTAINING OR REPAIRING AIRCRAFT, NOT OTHERWISE PROVIDED FOR

<u>Type*</u>	<u>Symbol</u>	<u>Indent Level Number of dots (e.g. 0, 1, 2)</u>	<u>Title</u> <u>“CPC only” text should normally be enclosed in {curly brackets}**</u>	<u>Transferred to#</u>
C	B64F 1/02	1	Arresting gear; Liquid barriers	B64F 1/02, B64F 1/027, B64F 1/029, B64F 1/0295, B64F 1/0297, B64F 1/0299
U	B64F 1/025	2	{using decelerating or arresting beds}	
N	B64F 1/027	2	{using net or mesh}	
N	B64F 1/029	2	{using a cable or tether}	
N	B64F 1/0295	2	{aerodynamically or aerostatically supported, e.g. parafoil or balloon}	
N	B64F 1/0297	2	{adjustable to align with aircraft trajectory}	
N	B64F 1/0299	2	{characterized by the use of multiple devices}	
C	B64F 1/32	1	for handling freight	B64F 1/32, B64F 1/322, B64F 1/324, B64F 1/326
N	B64F 1/322	2	{Cargo loaders specially adapted for loading air freight containers or palletized cargo into or out of the aircraft}	
N	B64F1/324	2	{Luggage loaders specially adapted for loading individual luggage items into or out of the aircraft}	
N	B64F 1/326	2	{Supply vehicles specially adapted for transporting catering to and loading into the aircraft}	

*N = new entries where reclassification into entries is involved; C = entries with modified file scope where reclassification of documents from the entries is involved; Q = new entries which are firstly populated with documents via administrative transfers from deleted (D) entries. Afterwards, the transferred documents into the Q entry will either stay or be moved to more appropriate entries, as determined by intellectual reclassification; T= existing entries with enlarged file scope, which receive documents from C or D entries, e.g. when a limiting reference is removed from the entry title; M = entries with no change to the file scope (no reclassification); D = deleted entries; F = frozen entries will be deleted once reclassification of documents from the entries is completed; U = entries that are unchanged.

NOTES:

- **No {curly brackets} are used for titles in CPC only subclasses, e.g. C12Y, A23Y; 2000 series symbol titles of groups found at the end of schemes (orthogonal codes); or the Y section titles. The {curly brackets} are used for 2000 series symbol titles found interspersed throughout the main trunk schemes (breakdown codes).
- U groups: it is obligatory to display the required “anchor” symbol (U group), i.e. the entry immediately preceding a new group or an array of new groups to be created (in case new groups are not clearly subgroups of C-type groups). Always include the symbol, indent level and title of the U group in the table above.
- All entry types should be included in the scheme changes table above for better understanding of the overall scheme change picture. Symbol, indent level, and title are required for all types .
- “Transferred to” column must be completed for all C, D, F, and Q type entries. F groups will be deleted once reclassification is completed.

CPC NOTICE OF CHANGES 800

DATE: JANUARY 1, 2020

PROJECT RP0430

- When multiple symbols are included in the “Transferred to” column, avoid using ranges of symbols in order to be as precise as possible.
- For administrative transfer of documents, the following text should be used: “< administrative transfer to XX>”, “<administrative transfer to XX and YY simultaneously>”, or “<administrative transfer to XX, YY, ...and ZZ simultaneously>” when administrative transfer of the same documents is to more than one place.
- Administrative transfer to main trunk groups is assumed to be the source allocation type, unless otherwise indicated.
- Administrative transfer to 2000/Y series groups is assumed to be “additional information”.
- If needed, instructions for allocation type should be indicated within the angle brackets using the abbreviations “ADD” or “INV”: <administrative transfer to XX ADD> , <administrative transfer to XX INV>, or < administrative transfer to XX ADD, YY INV, ... and ZZ ADD simultaneously>.
- In certain situations, the “D” entries of 2000-series or Y-series groups may not require a destination (“Transferred to”) symbol, however it is required to specify “<no transfer>” in the “Transferred to” column for such cases.
- For finalisation projects, the deleted “F” symbols should have <no transfer> in the “Transferred to” column.
- For more details about the types of scheme change, see CPC Guide.

CPC NOTICE OF CHANGES 800

DATE: JANUARY 1, 2020

PROJECT RP0430

B. New, Modified or Deleted Warning(s)

SUBCLASS B64C - AEROPLANES; HELICOPTERS

<u>Type*</u>	<u>Location</u>	<u>Old Warning</u>	<u>New/Modified Warning</u>
N	B64C 1/0009		Group B64C 1/0009 is impacted by reclassification into group B64C 39/029. Groups B64C 1/0009 and B64C 39/029 should be considered in order to perform a complete search.
N	B64C 2001/0045		Group B64C 2001/0045 is impacted by reclassification into group B64C 39/029. Groups B64C 2001/0045 and B64C 39/029 should be considered in order to perform a complete search.
N	B64C 1/068		Group B64C 1/068 is impacted by reclassification into groups B64C 1/0683 and B64C 1/0685. Groups B64C 1/068, B64C 1/0683, and B64C 1/0685 should be considered in order to perform a complete search.
N	B64C 1/0683		Group B64C 1/0683 is incomplete pending reclassification of documents from group B64C 1/068. Groups B64C 1/068 and B64C 1/0683 should be considered in order to perform a complete search.
N	B64C 1/0685		Group B64C 1/0685 is incomplete pending reclassification of documents from group B64C 1/068. Groups B64C 1/068 and B64C 1/0685 should be considered in order to perform a complete search.
N	B64C 3/10		Group B64C 3/10 is impacted by reclassification into group B64C 39/029. Groups B64C 3/10 and B64C 39/029 should be considered in order to perform a complete search.
N	B64C 3/16		Group B64C 3/16 is impacted by reclassification into group B64C 39/029. Groups B64C 3/16 and B64C 39/029 should be considered in order to perform a complete search.
N	B64C 7/00		Group B64C 7/00 is impacted by reclassification into group B64C 39/029. Groups B64C 7/00 and B64C 39/029 should be considered in order to perform a complete search.

CPC NOTICE OF CHANGES 800

DATE: JANUARY 1, 2020

PROJECT RP0430

<u>Type*</u>	<u>Location</u>	<u>Old Warning</u>	<u>New/Modified Warning</u>
N	B64C 39/00		Group B64C 39/00 is impacted by reclassification into group B64C 39/029. Groups B64C 39/00 and B64C 39/029 should be considered in order to perform a complete search.
N	B64C 39/029		Group B64C 39/029 is incomplete pending reclassification of documents from groups B64C1/0009, B64C2001/0045, B64C 3/10, B64C 3/16, B64C 7/00, and B64C 39/00. All groups should be considered in order to perform a complete search.

SUBCLASS B64F - GROUND OR AIRCRAFT-CARRIER-DECK INSTALLATIONS SPECIALLY ADAPTED FOR USE IN CONNECTION WITH AIRCRAFT; DESIGNING, MANUFACTURING, ASSEMBLING, CLEANING, MAINTAINING OR REPAIRING AIRCRAFT, NOT OTHERWISE PROVIDED FOR

<u>Type*</u>	<u>Location</u>	<u>Old Warning</u>	<u>New/Modified Warning</u>
N	B64F 1/02		Group B64F 1/02 is impacted by reclassification into groups B64F 1/027, B64F 1/029, B64F 1/0295, B64F 1/0297, and B64F 1/0299. All groups listed in this Warning should be considered in order to perform a complete search.
N	B64F 1/027		Group B64F 1/027 is incomplete pending reclassification of documents from group B64F 1/02. Groups B64F 1/02 and B64F 1/027 should be considered in order to perform a complete search.
N	B64F 1/029		Group B64F 1/029 is incomplete pending reclassification of documents from group B64F 1/02. Groups B64F 1/02 and B64F 1/029 should be considered in order to perform a complete search.
N	B64F 1/0295		Group B64F 1/0295 is incomplete pending reclassification of documents from group B64F 1/02. Groups B64F 1/02 and B64F 1/0295 should be considered in order to perform a complete search.

CPC NOTICE OF CHANGES 800

DATE: JANUARY 1, 2020

PROJECT RP0430

<u>Type*</u>	<u>Location</u>	<u>Old Warning</u>	<u>New/Modified Warning</u>
N	B64F 1/0297		Group B64F 1/0297 is incomplete pending reclassification of documents from group B64F 1/02. Groups B64F 1/02 and B64F 1/0297 should be considered in order to perform a complete search.
N	B64F 1/0299		Group B64F 1/0299 is incomplete pending reclassification of documents from group B64F 1/02. Groups B64F 1/02 and B64F 1/0299 should be considered in order to perform a complete search.
N	B64F 1/32		Group B64F 1/32 is impacted by reclassification into groups B64F 1/322, B64F 1/324, and B64F 1/326. All groups listed in this Warning should be considered in order to perform a complete search.
N	B64F 1/322		Group B64F 1/322 is incomplete pending reclassification of documents from group B64F 1/32. Groups B64F 1/32 and B64F 1/322 should be considered in order to perform a complete search.
N	B64F 1/324		Group B64F 1/324 is incomplete pending reclassification of documents from group B64F 1/32. Groups B64F 1/32 and B64F 1/324 should be considered in order to perform a complete search.
N	B64F 1/326		Group B64F 1/326 is incomplete pending reclassification of documents from group B64F 1/32. Groups B64F 1/32 and B64F 1/326 should be considered in order to perform a complete search.

*N = new warning, M = modified warning, D = deleted warning

NOTE: The "Location" column only requires the symbol PRIOR to the location of the warning. No further directions such as "before" or "after" are required.

2. A. DEFINITIONS (new)

Insert: The following new **B64C** definitions.

B64C 1/0683

Definition statement

This place covers:

Constructional features specially adapted for the nose of the fuselage.

References

Informative references

Attention is drawn to the following places, which may be of interest for search:

Nose cones for missiles or torpedoes	F42B 10/46 , F42B 10/52
--------------------------------------	--

B64C 1/0685

Definition statement

This place covers:

Constructional features specially adapted for the aft end of the fuselage.

References

Informative references

Attention is drawn to the following places, which may be of interest for search:

Mountings for vertical or horizontal stabilizers	B64C 1/26
Mountings for auxiliary power units	B64D 2041/002

B64C 39/029

Definition statement

This place covers:

Aircraft that lack symmetry with respect to a longitudinal vertical plane.

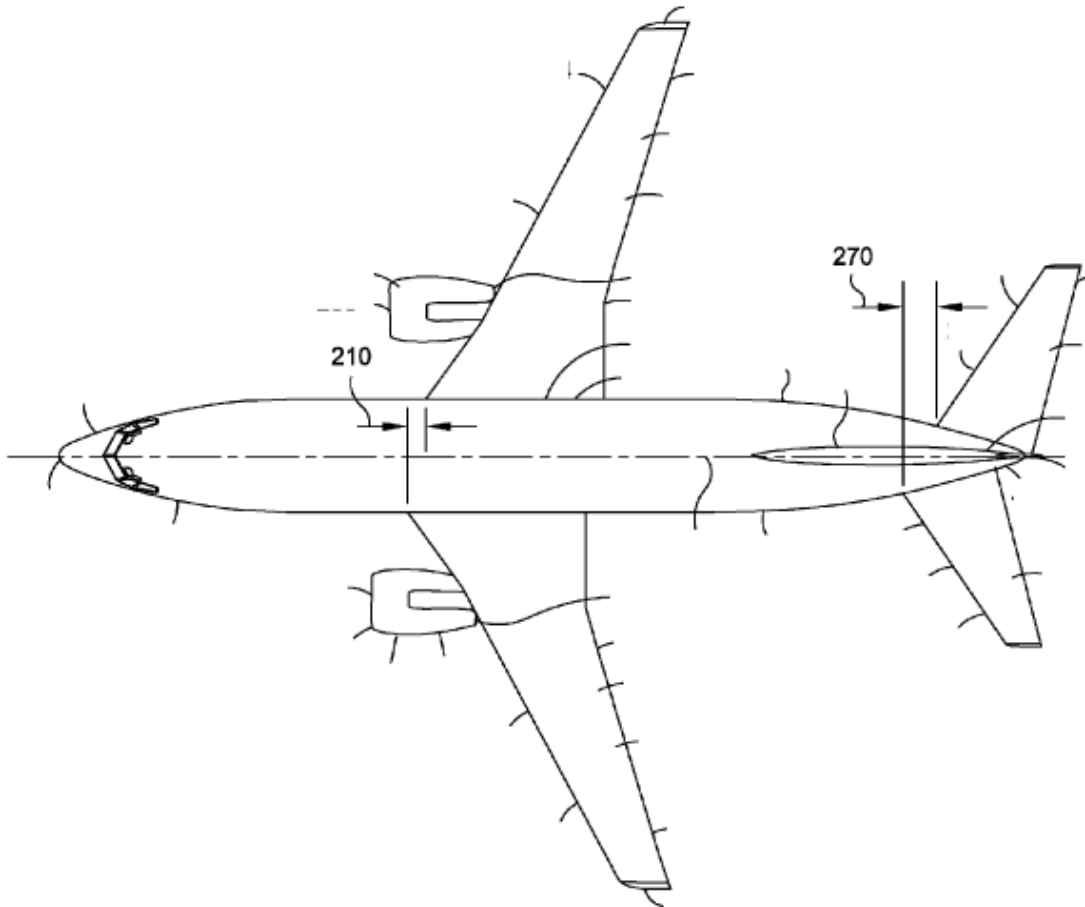

References

References out of a residual place

Examples of places in relation to which this place is residual:

Rotorcraft asymmetry due to placement of auxiliary rotor or fluid-jet device for counter-balancing lifting rotor torque

B64C 27/82

2. A. DEFINITIONS (new)

Insert: The following new **B64F** definitions.

B64F 1/027

Definition statement

This place covers:

Devices for arresting or capturing aircraft using nets or mesh.

B64F 1/029

Definition statement

This place covers:

Devices for arresting or capturing aircraft using cables or tethers.

B64F 1/0295

Definition statement

This place covers:

Arresting or capture devices that are supported via airborne means.

References

Informative references

Attention is drawn to the following places, which may be of interest for search:

Releasing or reberthing aircraft in flight
--

B64D 5/00

DATE: JANUARY 1, 2020

PROJECT RP0430

B64F 1/0297

Definition statement

This place covers:

Devices which, when deployed, may be altered to arrest or capture aircraft from differing flight path angles.

B64F 1/0299

Definition statement

This place covers:

Systems using multiple of the same or differing type of arresting or capturing devices.

B64F 1/322

Definition statement

This place covers:

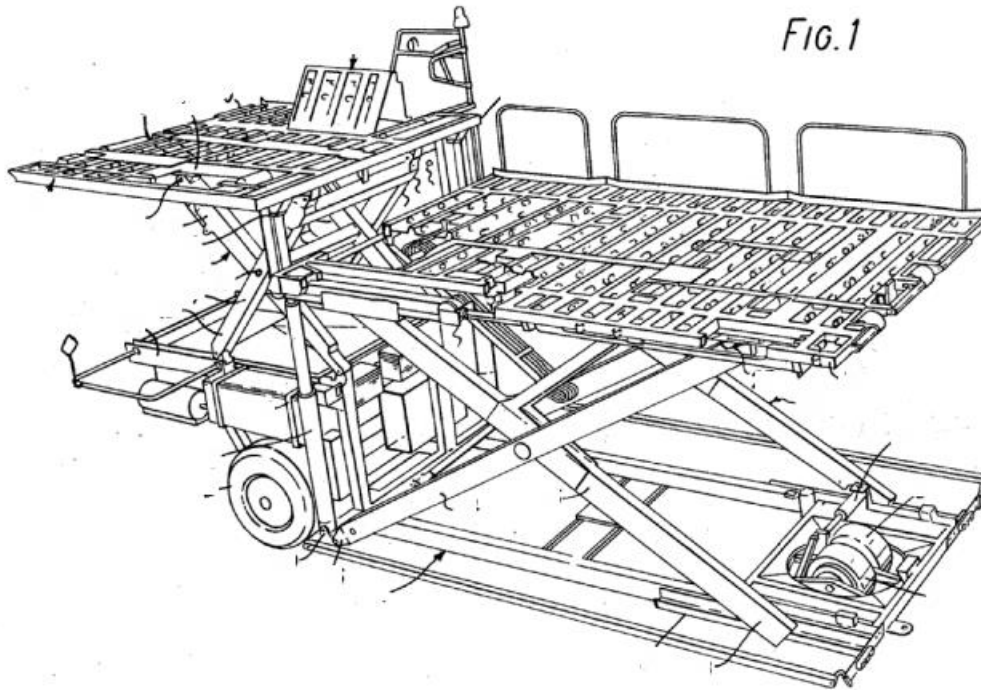

B64F 1/324

Definition statement

This place covers:

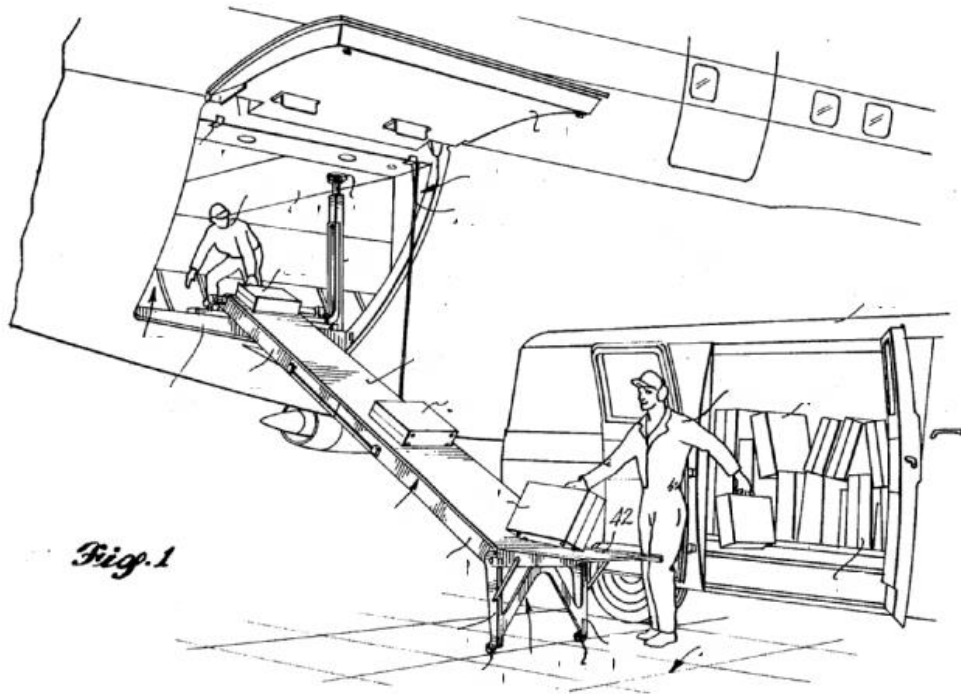

B64F 1/326

Definition statement

This place covers:

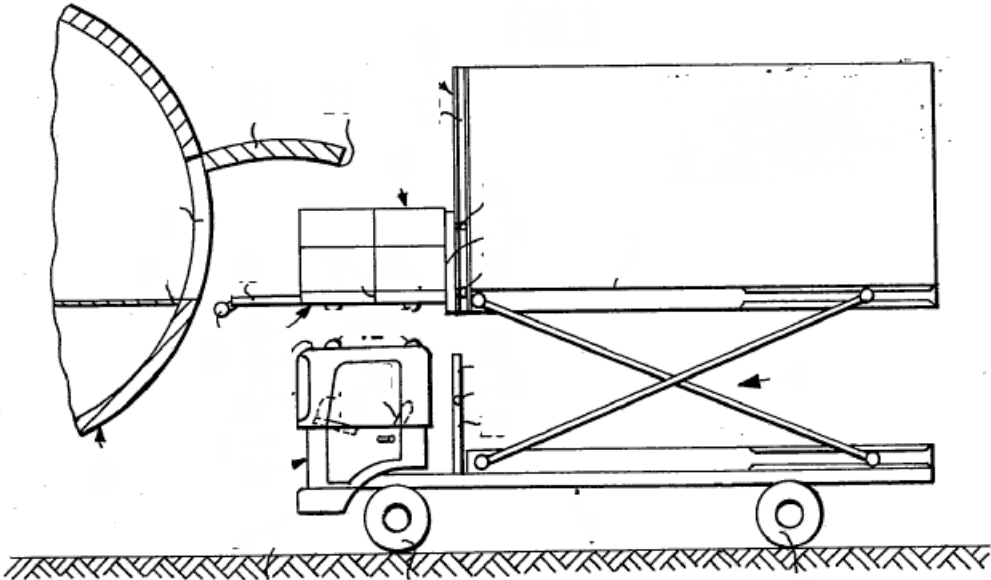

2. A. DEFINITIONS (Modified)

B64C 37/02

Delete: The entire Relationships with other classification places section shown below.

Relationships with other classification places

In-flight refuelling : [B64D39/00](#)

Aircraft adaptations to facilitate towing or being towed: [B64D3/00](#)

Aircraft transported by aircraft: [B64D5/00](#)

Aircraft having multiple fuselages or tail booms: [B64C39/04](#)

Insert: The following new Limiting references section and rows.

References

Limiting references

This place does not cover:

In-flight refuelling	B64D 39/00
Aircraft adaptations to facilitate towing or being towed	B64D 3/00
Aircraft transported by aircraft	B64D_5/00

Insert: The following new Informative references section and row.

Informative references

Attention is drawn to the following places, which may be of interest for search:

Aircraft having multiple fuselages or tail booms	B64C 39/04
--	----------------------------

2. A. DEFINITIONS (Modified)

B64F 1/32

Definition statement

This place covers:

Replace: All text in the Definition statement with the following new text.

Ground installations or vehicles specially adapted for loading freight into and out of an aircraft, e.g. scissors type trucks.

CPC NOTICE OF CHANGES 800

DATE: JANUARY 1, 2020

PROJECT RP0430

2. B. DEFINITIONS QUICK FIX

<u>Symbol</u>	<u>Location of change</u> (e.g., section title)	<u>Existing reference symbol or text</u>	<u>Action; New symbol; New text</u>
B64F 1/02	Special rules of classification	“There will be an indexing scheme for the following: Runway arresting surfaces“	<u>Delete:</u> The <u>entire</u> Special rules of classification section. Special rules of classification There will be an indexing scheme for the following: Runway arresting surfaces
B64F 1/362	Special rules of classification	“There will be an indexing scheme for the following: Helicopter landing pads; e.g. portable, visual aids therefor “	<u>Delete:</u> The <u>entire</u> Special rules of classification section. Special rules of classification There will be an indexing scheme for the following: Helicopter landing pads; e.g. portable, visual aids therefor

NOTES:

- The table above is used for corrections or modifications to existing definitions, e.g. delete an entire definition or part thereof; propose new wording or modify wording of a section, change the symbol the definition is associated with, change or delete a reference symbol, etc.
- Do not delete (F) symbol definitions.

CPC NOTICE OF CHANGES 800

DATE: JANUARY 1, 2020

PROJECT RP0430

3. REVISION CONCORDANCE LIST (RCL)

<u>Type*</u>	<u>From CPC Symbol (existing)</u>	<u>To CPC Symbol(s)</u>
C	B64C 1/0009	B64C 1/0009, B64C 39/029
C	B64C 2001/0045	B64C 2001/0045, B64C 39/029
C	B64C 1/068	B64C 1/068, B64C 1/0683, B64C 1/0685
C	B64C 3/10	B64C 3/10, B64C 39/029
C	B64C 3/16	B64C 3/16, B64C 39/029
C	B64C 7/00	B64C 7/00, B64C 39/029
C	B64C 39/00	B64C 39/00, B64C 39/029
C	B64F 1/02	B64F 1/02, B64F 1/027, B64F 1/029, B64F 1/0295, B64F 1/0297, B64F 1/0299
C	B64F 1/32	B64F 1/32, B64F 1/322, B64F 1/324, B64F 1/326

* C = entries with modified file scope where reclassification of documents from the entries is involved; Q = new entries which are firstly populated with documents via administrative transfers from deleted (D) entries. Afterwards, the transferred documents into the Q entry will either stay or be moved to more appropriate entries, as determined by intellectual reclassification; D = deleted entries; F = frozen entries will be deleted once reclassification of documents from the entries is completed.

NOTES:

- Only C, D, F, and Q type entries are included in the table above.
- When multiple symbols are included in the “To” column, do not use ranges of symbols.
- For administrative transfer of documents, the following text should be used: “< administrative transfer to XX>”, “<administrative transfer to XX and YY simultaneously>”, or “<administrative transfer to XX, YY, ...and ZZ simultaneously>” when administrative transfer of the same documents is to more than one place.
- Administrative transfer to main trunk groups is assumed to be the source allocation type, unless otherwise indicated.
- Administrative transfer to 2000/Y series groups is assumed to be “additional information”.
- If needed, instructions for allocation type should be indicated within the angle brackets using the abbreviations “ADD” or “INV”: <administrative transfer to XX ADD>, <administrative transfer to XX INV>, or < administrative transfer to XX ADD, YY INV, ... and ZZ ADD simultaneously>.
- In certain situations, the “D” entries of 2000-series or Y-series groups may not require a destination (“To”) symbol, however it is required to specify “<no transfer>” in the “To” column for such cases.
- RCL is not needed for finalisation projects.

CPC NOTICE OF CHANGES 800

DATE: JANUARY 1, 2020

PROJECT RP0430

4. CHANGES TO THE CPC-TO-IPC CONCORDANCE LIST (CICL)

<u>CPC</u>	<u>IPC</u>	<u>Action*</u>
B64C 1/0683	B64C 1/06	new
B64C 1/0685	B64C 1/06	new
B64C 39/029	B64C 39/00	new

<u>CPC</u>	<u>IPC</u>	<u>Action*</u>
B64F 1/027	B64F 1/02	new
B64F 1/029	B64F 1/02	new
B64F 1/0295	B64F 1/02	new
B64F 1/0297	B64F 1/02	new
B64F 1/0299	B64F 1/02	new
B64F 1/322	B64F 1/32	new
B64F 1/324	B64F 1/32	new
B64F 1/326	B64F 1/32	new

*Action column:

- For an (N) or (Q) entry, provide an IPC symbol and complete the Action column with “NEW.”
- For an existing CPC main trunk entry or indexing entry where the existing IPC symbol needs to be changed, provide an updated IPC symbol and complete the Action column with “UPDATED.”
- For a (D) CPC entry or indexing entry complete the Action column with “DELETE.” IPC symbol does not need to be included in the IPC column.
- For an (N) 2000 series CPC entry which is positioned within the main trunk scheme (breakdown code) provide an IPC symbol and complete the action column with “NEW”.
- For an (N) 2000 series CPC entry positioned at the end of the CPC scheme (orthogonal code), with no IPC equivalent, complete the IPC column with “CPCONLY” and complete the action column with “NEW”.

NOTES:

- F symbols are not included in the CICL table above.
- T and M symbols are not included in the CICL table above unless a change to the existing IPC is desired.